



BELTS BY TIMKEN

INDUSTRIAL POWER TRANSMISSION BELTS



TIMKEN

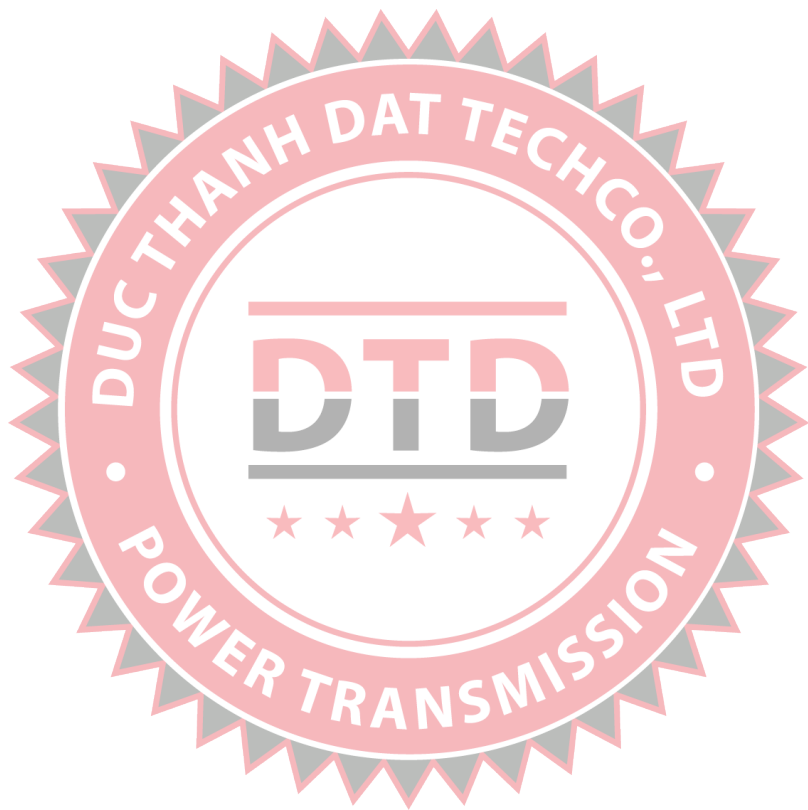

Carlisle® Belts by Timken

Introduction



Timken, the manufacturer of Carlisle® belts, is proud to present this comprehensive product catalog, affording you easy access to the latest Carlisle belts product information and technical specifications.

We invite you to grow your business with this broad line of premium power transmission products that deliver optimal performance you can depend on.

Our People

Timken's strength lies in the performance of its people. For over a century, Timken has adhered to a philosophy of supplying innovative products, unrivaled quality, and superior customer service.

Our Service

Carlisle belts by Timken are supplied to distributors and original equipment manufacturers who seek the optimum in quality and service. Every belt is backed by extraordinary engineering and technical support, and by our personal, knowledgeable, and attentive customer service team.

On-Time Delivery

Understanding the importance of on-time delivery and fast turnaround, Timken's flexible manufacturing model and short lead times provide responsive, reliable delivery that will meet or exceed your expectations.

Proudly Made in the USA

A comprehensive product line is made in ISO registered manufacturing facilities in the USA by a proud team of engineers, technicians, and craftsmen. The icon below is used throughout this catalog to identify each product line that is manufactured in Timken's Springfield, Missouri or Fort Scott, Kansas plants.



Carlisle® Belts by Timken

Performance Driven...Performance Proven

It's no accident that Carlisle® belts are built by Timken to outlast and outperform competitors belts. That's why recognized original equipment manufacturers turn to Timken to private-brand Carlisle belts for their products.

Every Carlisle belt is the result of science, engineering, and years of experience. Timken's innovative product development, specially formulated components, time-tested methods, and state-of-the-art manufacturing techniques set us apart from the competition.

The team of belt experts at the Timken Technical Center in Springfield, Missouri is dedicated to the development and testing of new and existing products to assure that Carlisle belts provide outstanding performance in a multitude of the toughest, most demanding applications.

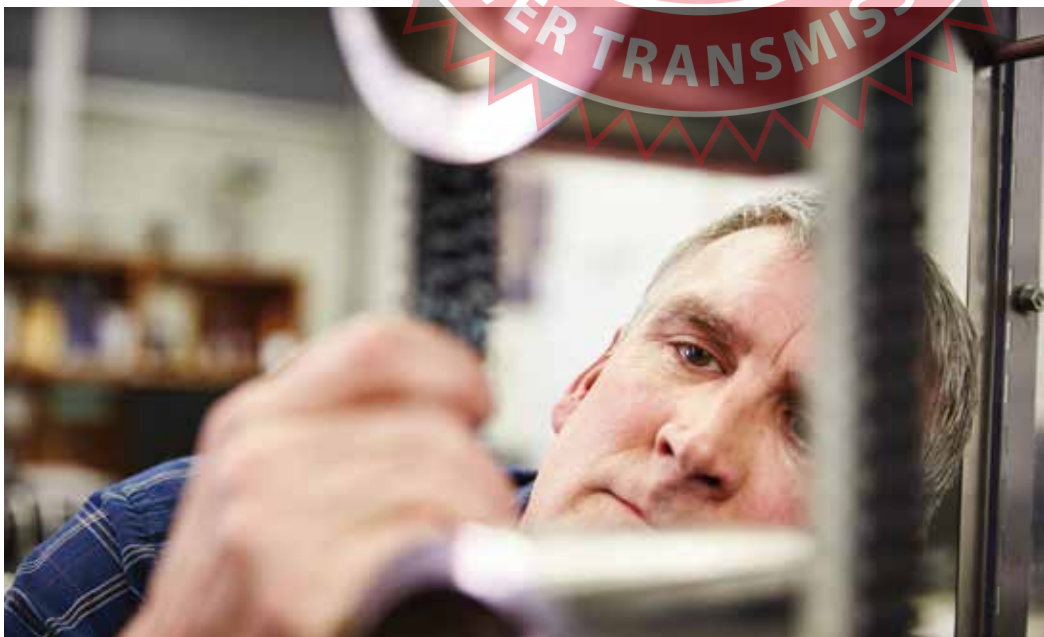

Carlisle® Belts by Timken

Performance Driven...Performance Proven



Chek Mate® V-Belt Matching

Chek Mate® is a manufacturing process that holds v-belt lengths within ARPM (Association for Rubber Products Manufacturers) tolerances for a matched set. Matching numbers are not required on these Carlisle® belts which carry the distinctive Chek Mate logo: Super Blue Ribbon®, Super II®, Super Power-Wedge®, Power-Wedge® Cog-Belt® and Gold-Ribbon® Cog-Belt®.

ISO Registration

Timken belt plants and Technical Center are registered as compliant with the International Standard ISO 9001.

ISO 9001 requirements include:

- Management that is committed, involved, focused and responsive
- People who are organized, responsible, authorized, competent, empowered and knowledgeable
- Processes that are visible, traceable, consistent, repeatable, measurable and documentable
- Documents that are appropriate, relevant, simple, understandable and consistent with processes in use

ISO 9001 certification ensures that organizations take time to understand their key quality processes, that the processes are implemented and followed by everyone in the organization and that the processes are documented and maintained to a degree that can be demonstrated to an outside agency.



Carlisle® Belts by Timken









The Right Belt for the Job®

You can depend on Carlisle® belts for a wide range of applications. We've got you covered with the right belt for most any job. Timken manufactures Carlisle belts in the USA from 3" to 900" for anything and everything – fans, mixers, pumps, conveyors, machine tools, centrifuges, robotics, and all types of industrial machines.

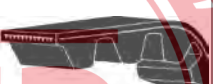
Carlisle belts are purpose-built and designed for optimal performance on the most demanding applications:

- Aggregate
- HVAC/R
- Outdoor Power Equipment
- Powersports
- Agriculture
- Industrial Machinery
- Petrochemical
- Wood/Paper

The world's leading manufacturers specify Carlisle belts by Timken to keep their equipment running.

Panther® XT Synchronous Belt	
	Alternative to chain or drop-in replacement for polyurethane belts. Higher torque capacity than Panther. Formulated for enhanced performance and strength.
Panther® Synchronous Belt	
	Designed to improve performance and drive life while reducing maintenance and downtime. Higher torque capacity than Synchro-Cog® HT.
Synchro-Cog® HT Synchronous Belt	
	Delivers trouble-free power transmission with a smooth, quiet and efficient drive system.
Dual Synchronous Belt	
	Provides synchronized transfer of power from both sides of the belt for greater flexibility and efficiency in your drive design.
Synchro-Cog® Timing Belt	
	Trapezoidal tooth profile for clean, quiet operation on applications where synchronization between the driver and driven unit is required.
Air Cool Heat Exchange Belt	
	Air Cool Heat Exchange Belts have a special "Z" twist cord construction designed to perform on air cooled heat exchange applications.
Cotton Drive® Timing Belt	
	1" pitch timing belts designed for use on cotton cleaning machines. Uniquely constructed to handle this harsh, abrasive application.
Gold-Ribbon® Cog-Belt®	
	The Energy Saver! Reduce downtime and save energy with the benchmark for classical v-belt performance.
Super II® V-Belt	
	The Problem Solver! The solution to the constant and costly problem of replacing ordinary v-belts on troublesome drives.

Carlisle® Belts by Timken

The Right Belt for the Job®

Super Blue Ribbon® V-Belt 	<p>The finest wrapped belt in the industry and workhorse of classical v-belts.</p>	Wedge-Band 	<p>Banded version of Super Power-Wedge. Belt whip and turnover are eliminated.</p>
Aramax® Xtra Duty V-Belt 	<p>Designed for outdoor power equipment and aggressive applications with heavy shock loads. Delivers more horsepower, less stretch and longer service life.</p>	Aramax® Wedge-Band® 	<p>Designed for extraordinary banded belt strength on the toughest drives. Belt whip and turnover are eliminated.</p>
Power-Wedge® Cog-Belt® 	<p>Combines the advantages of the narrow belt wedge design with raw edge performance for maximum operating efficiency in a compact drive package. Also available: Metric Power-Wedge Cog-Belt.</p>	Wedge-Band® Chipper Drive 	<p>Specially designed and constructed to meet the unique demands of the forestry industry. Belt whip and turnover are eliminated.</p>
Super Power-Wedge® V-Belt 	<p>Enables design of a more compact belt drive. Ideal for heavy duty industrial drives with shock loads.</p>	Super Vee-Band® 	<p>Banded version of Super Blue Ribbon. Belt whip and turnover are eliminated.</p>
Double Angle V-Belt 	<p>Ideally suited for serpentine drives where power needs to be transmitted equally from both sides of the belt.</p>	Durapower® II FHP V-Belt 	<p>Raw edge construction improves efficiency, performance and belt life.</p>
Vee-Rib™ Belt 	<p>Provides smooth, vibration-free performance in a compact drive. Ideally suited for high speed drives where conventional v-belts cannot operate.</p>	Dry Can Belt 	<p>The original deep-groove notched design specifically developed for demanding textile industry double angle "CC" drives.</p>
Variable Speed Cog-Belt® 	<p>For use with variable pitch pulleys to gain a wide range of driven speeds.</p>	Thoro-Twist™ V-Belting 	<p>For use on drives that have no take-up adjustment capability or for emergency replacement.</p>
Gold-Ribbon® Cog-Band® 	<p>Combines the superior characteristics of the Gold-Ribbon Cog-Belt with the stability of a banded belt. Belt whip and turnover are eliminated.</p>	Round Belts 	<p>High performance solution for conveyors, quarter-turn, twisted, and serpentine drives.</p>
Power-Wedge® Cog-Band® 	<p>Banded version of Power-Wedge Cog-Belt. Belt whip and turnover are eliminated.</p>		

Carlisle® Belts by Timken

A History of Innovation... A Tradition of Excellence

A commitment to quality, customers, and state-of-the-art manufacturing processes has remained steadfast throughout the long and rich history of the Timken belts business.

Maintaining a tradition of excellence for more than 100 years – Carlisle® belts continue to bring superior performance with unsurpassed reliability to the toughest industrial applications.

- 1905 Dayton Rubber Manufacturing Company (DRMC) founded in Dayton, Ohio
- 1921 DRMC develops first Raw Edge v-belt
- 1926 DRMC patents cog-type Raw Edge v-belt
- 1934 DRMC pioneers use of synthetic rubber technology
- 1957 DRC develops arched cross section v-belts for agricultural applications
- 1959 new belt manufacturing plant opens in Springfield, Missouri
- 1960 DRMC becomes Dayco
- 1985 Dayco introduces first chloroprene FHP v-belt
- 1986 new belt plant opens in Fort Scott, Kansas
- 1988 Dayco introduces first high performance CVT belt
- 1990 Pirelli Power Transmission acquires Durkee-Atwood
- 1993 Dayco acquires Pirelli Power Transmission
- 1994 Dayco introduces RPP® Panther® belts
- 1995 Dayco introduces Super II® classical v-belt line
- 2001 Carlisle Companies Inc. acquires the industrial belt division of Dayco forming Carlisle Power Transmission
- 2011 Carlisle combines Carlisle Tire and Wheel and Carlisle Power Transmission forming Carlisle Transportation Products
- 2013 Carlisle Transportation Products is acquired by American Industrial Partners (AIP) forming The Carlstar Group LLC
- 2015 The Timken Company acquires the belts business from Carlstar





Catalog Features

Iron Clad Guarantee.

All Carlisle® belts by Timken are backed by our Ironclad Guarantee. Warranty terms are set forth below. If not completely satisfied with the performance of a Carlisle belt when properly installed on a drive, return it to an authorized Timken distributor of Carlisle belts who will replace the product or refund the original purchase price.

We're confident that once you've tried Carlisle belts by Timken, you'll never be satisfied with anything less.

Carlisle Belts by Timken Limited Warranty

All Carlisle belts by Timken are warranted for the period of twelve (12) months from the date of sale to the initial customer to be free from defects in material and workmanship under normal operating conditions of recommended usage. This limited warranty does not apply to any belt which has been improperly installed or has been subjected to improper use. Neither distributors nor OEM customers have authority to make or give any additional warranty or representation to consumers and shall not hold itself out, whether as agent or otherwise, as having authority. This limited warranty is provided in lieu of any other warranty, express or implied, including any warranty of merchantability or fitness for a particular purpose.

Purchaser's exclusive remedy for any breach of this limited warranty is for the replacement of the belt which is proven to be non-conforming or defective, or refund of the purchase price at Seller's discretion. In no event shall Seller be liable for any other costs or damages, such as indirect, incidental, punitive, special or consequential damages, or lost profits, lost revenue or recall costs.

In order to make a claim under the terms of this Limited Warranty, purchaser must notify Seller in writing within thirty days of period after discovery of the claimed defect and shall furnish substantiating documentation. Purchaser, if requested, shall return the product to afford Seller the opportunity to inspect and analyze the product.

Standard Belt Sizes

Certain non-stock sizes (indicated by *) are shown in the catalog. Please contact Customer Service for Carlisle belts availability. Extended lead time and minimum order quantities may apply.

Belt and Pulley Measurements

Cross-sectional dimensions and lengths are shown for belts. Dimensions are also listed for sheaves and sprockets.

Recommended Metal for Belt Types

For quick reference, each belt section includes the recommended sheave or sprocket.

Belt and Pulley Weights

Product weight is indicated for each size.

Troubleshooting Guide

Common symptoms and possible causes of short belt life are included for synchronous and v-belts.

Brand Interchange

The interchange helps convert other brands to the correct Carlisle belts by Timken product.

Made-to-Order

This catalog is intended as a complete guide to the standard line of Carlisle belts by Timken. Special belt types and constructions not shown in this catalog may also be available by special order. Please contact Customer Service for Carlisle belts at 866-773-2926 for price and availability.

Drive Design

Technical information may be obtained from "Drive Engineer," Timken's drive design software available at www.CarlisleBelts.com/drive-engineer.

A staff of Drive Specialists stands ready to assist with drive design, belt maintenance seminars, and any help needed with choosing the right belt for the application. Your Timken authorized distributor of Carlisle belts will also be an invaluable resource.

Timken is a proud member of:



WARNING

Failure to observe the following warnings could create a risk of death or serious injury.

Static electricity created by a belt in operation can ignite an explosive atmosphere. Special care must be taken in the utilization of belts in or near locations which may contain explosive concentrations of combustible gases or accumulations of dust such as grain, coal, or other combustible materials.

Proper dissipation of such potential static electricity discharge must be assured to prevent any such explosion.

Aircraft Warning:

Carlisle® belts by Timken are not designed or intended for aircraft use. Do not use Carlisle belts or pulleys on aircraft propeller, rotor or accessory drives. Do not use Carlisle belts or pulleys on helicopters or private, commercial, or ultralight aircraft.



CAUTION

Failure to observe the following cautions could create a risk of serious physical injury or property damage.

Proper selection and installation of drive belts are critical tasks. Belts must be properly selected and fitted to assure proper performance. Always follow equipment manufacturer installation and fitting directions and selection guides.

The following are trademarks or registered trademarks of The Timken Company or its affiliates.

Aramax®
Belt-Finder®
Blue Label™
Blue Ribbon®
Big Shot®
Chek Mate®
Cog-Band®
Cog-Belt®
Cotton Drive®
Durapower®
Frequency Finder™
Gold-Ribbon®
Panther®
Power-Wedge®
Raw Edge™
RPP®
Super Blue Ribbon®
Super II®
Synchro-Cog®
Tension-Finder®
The Right Belt for the Job®
Thoro-Twist™
Ultra-Cord®
Vee-Band®
Vee-Rib™
Wedge-Band®

Contact Us:

Timken strives for accuracy in all publications. If you discover an error or need more information, please contact the Timken belts Customer Service team at 866-773-2926 or email belts@timken.com.

The Timken Company (NYSE: TKR; www.timken.com) added Carlisle® belts to its power transmission portfolio in September 2015. Timken engineers, manufactures and markets bearings, transmissions, gearboxes, belts, chain and related products.

Index

Carlisle Belts by Timken Catalog



Introduction	i
Performance Driven...Performance Proven	ii
Chek Mate® V-Belt Matching	iii
The Right Belt for the Job®	iv
A History of Innovation...A Tradition of Excellence	vi
Ironclad Guarantee	vii
Index	1
Synchronous Belts	4
Panther®XT	5
Panther®	12
Panther® Sleeves	24
Synchro-Cog® HT	26
Synchro-Cog® HT Sleeves	52
Dual Synchronous	59
Dual Synchronous Sleeves	64
Synchro-Cog® Timing Belt	66
Synchro-Cog® Timing Belt Sleeves	76
Air Cool Heat Exchange Belt	78
Air Cool Heat Exchange Sleeves	81
Cotton Drive®	82
Heavy Duty V-Belts	86
Gold-Ribbon® Cog-Belt®	87
Super II® V-Belt	94
Super Blue Ribbon®	101
Aramax® Xtra Duty	112
Power-Wedge® Cog-Belt®	118
Metric Power-Wedge® Cog-Belt®	123
Super Power-Wedge®	127
Double Angle V-Belt	130
Vee-Rib™ Belt	135
Vee-Rib™ Sleeve	145
Variable Speed Cog-Belt®	146

Index

Carlisle Belts by Timken Catalog



Banded Belts	154
Gold-Ribbon® Cog-Band®	155
Power-Wedge® Cog-Band®	159
Wedge-Band®	162
Aramax® Wedge-Band®	167
Wedge-Band® Chipper Drive	171
Super Vee-Band®	173
Light-Duty Belts	178
Durapower® II FHP Belt	179
Specialty Belts	185
Dry Can Specialty Belt	185
Thoro-Twist™ Belting	187
Round Belt	189



Index

Carlisle Belts by Timken Catalog



Metal	194
Martin® Sprockets, Sheaves & Bushings Index . . .	194
Martin® Synchronous Drives	196
Martin® V-Belt Drives	248
Interchangeable Bushings	325
General Information	334
Static Conductive Belts	334
V-Belt Construction	335
V-Belt Drive Advantages	335
V-Belt Troubleshooting Guide	336
Synchronous Belt Drive Troubleshooting Guide . .	337
V-Belt Installation Checklist	338
V-Belt Selection Guide	338
Banded V-Belt Matching Limits	340
Spring-Loaded Belt Tensiometer	340
V-Belt Tensioning Guide	341
Brand Name Interchange	342
Recommended Sheave Diameters	345
Proper V-Belt Storage Guide	345
Tools	346
Drive Engineer™	346
PowerMiser™	347
Industrial V-Belt Drives Service Manual	347
Tension-Finder®	348
Spring-Loaded Tensiometer	348
Frequency-Finder™	349
Big Shot Tensioning Device	349
Laser-Align	350
Belt-Finder®	350
Wallboard Display	351
Sheave Gauges	351

Panther[®]XT

Synchronous Drive Belt



Panther[®]XT

Synchronous Drive Belt

PANTHER^{XT}

1 Carbon Cord Construction
High-modulus carbon fiber cord
High tensile strength
Minimal stretch
Increased durability

2 Engineered Tooth Fabric
Low-friction
Abrasion resistant
Extended belt life

3 HSN Rubber Compound
Reduced noise
High elasticity
Heat resistant (up to 120°C/248°F)
Oil resistant
High hardness
Improved performance in harsh conditions

Recommended Sprockets:
MPC Sprockets – MPB, Taper Bushed (8mm, 14mm)

Strong...
Like a Panther

Quiet...
Like a Panther

Runs...
Like a Panther

Purrs...
Like a Panther

Applications:
Printing machinery
Textile equipment
Packaging machinery
Compressors
Roller chain drives
Drop-in replacement for polyurethane belts & More

Synchronous Belts

Panther[®]XT

Synchronous Drive Belt

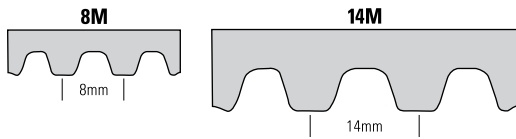

Our Panther[®]XT outlives the pack...by nine lives!



Panther[®]XT...PURRFECT TIMING

The strong, silent type, Panther[®]XT is the high torque synchronous belt that purrrs.

A powerful alternative to chain or a drop-in replacement for polyurethane belts, PantherXT offers higher torque capacity than the Panther[®] synchronous belt and is engineered to run quietly and efficiently in the harshest environments. Naturally agile, PantherXT moves quickly and easily to help achieve power ratings that easily meet or exceed the competition.

Carbon cord construction and abrasion-resistant, low friction tooth fabric promise the equivalent of nine lives of reduced downtime, maintenance, and noise levels.

RUNS like a panther

- PantherXT is engineered to achieve higher power ratings
- Designed for efficiency, PantherXT minimizes drive widths resulting in more compact drive designs and reduced metal costs

STRONG like a panther

- Carbon cord construction with high tensile strength and minimal stretch increases durability
- Fabric is engineered to be low-friction and abrasion-resistant for extended belt life
- Oil/heat resistant up to 120°C/248°F
- HSN rubber combines high elasticity and hardness for improved performance in harsh environments

QUIET like a panther

- Rubber construction and special fabric design reduce high frequency noise substantially when compared to polyurethane belt construction

PANTHER[®]XT Break Strength Comparison

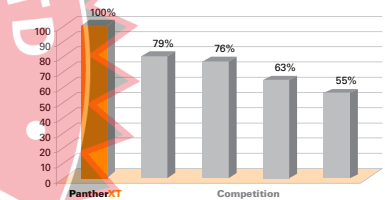

PANTHER[®]XT Belt Life Comparison

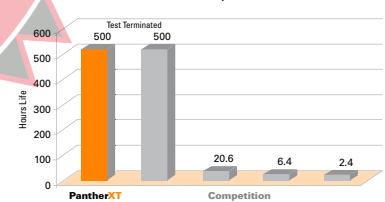

PANTHER[®]XT Maximum Operating Temperature

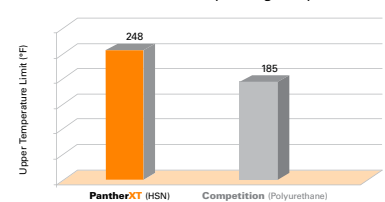

PANTHER[®]XT Tooth Shear Strength Comparison

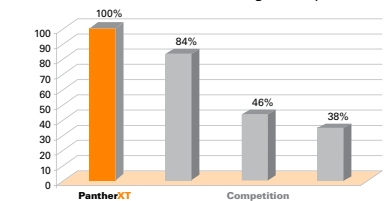

Panther[®]XT

Synchronous Drive Belt

Panther[®]XT Part Numbers

Part Number Example: **8MXT-640-12** = **8M** **XT** - **640** - **12**
Tooth Pitch PantherXT Construction Pitch Length (millimeters) Width (millimeters)

Part Number	Number Of Teeth	Pitch Length		Weight (lbs)
		(mm)	(in)	
8MXT Pitch – Recommended Sprockets: MPC Sprockets – MPB, Taper Bushed (8mm)				
8MXT-640-12	80	640	25.2	0.08
8MXT-640-21	80	640	25.2	0.14
8MXT-640-36	80	640	25.2	0.24
8MXT-640-62	80	640	25.2	0.41
8MXT-720-12	90	720	28.3	0.09
8MXT-720-21	90	720	28.3	0.16
8MXT-720-36	90	720	28.3	0.27
8MXT-720-62	90	720	28.3	0.46
8MXT-800-12	100	800	31.5	0.10
8MXT-800-21	100	800	31.5	0.17
8MXT-800-36	100	800	31.5	0.30
8MXT-800-62	100	800	31.5	0.51
8MXT-896-12	112	896	35.3	0.11
8MXT-896-21	112	896	35.3	0.19
8MXT-896-36	112	896	35.3	0.33
8MXT-896-62	112	896	35.3	0.57
8MXT-960-12	120	960	37.8	0.12
8MXT-960-21	120	960	37.8	0.21
8MXT-960-36	120	960	37.8	0.36
8MXT-960-62	120	960	37.8	0.62
8MXT-1000-12	125	1000	39.4	0.12
8MXT-1000-21	125	1000	39.4	0.22
8MXT-1000-36	125	1000	39.4	0.37
8MXT-1000-62	125	1000	39.4	0.64
8MXT-1040-12	130	1040	40.9	0.13
8MXT-1040-21	130	1040	40.9	0.23
8MXT-1040-36	130	1040	40.9	0.39
8MXT-1040-62	130	1040	40.9	0.67
8MXT-1120-12	140	1120	44.1	0.14
8MXT-1120-21	140	1120	44.1	0.24
8MXT-1120-36	140	1120	44.1	0.42
8MXT-1120-62	140	1120	44.1	0.72
8MXT-1200-12	150	1200	47.2	0.15

Part Number	Number Of Teeth	Pitch Length		Weight (lbs)
		(mm)	(in)	
8MXT Pitch – Recommended Sprockets: MPC Sprockets – MPB, Taper Bushed (8mm)				
8MXT-1200-21	150	1200	47.2	0.26
8MXT-1200-36	150	1200	47.2	0.45
8MXT-1200-62	150	1200	47.2	0.77
8MXT-1224-12	153	1224	48.2	0.15
8MXT-1224-21	153	1224	48.2	0.27
8MXT-1224-36	153	1224	48.2	0.46
8MXT-1224-62	153	1224	48.2	0.78
8MXT-1280-12	160	1280	50.4	0.16
8MXT-1280-21	160	1280	50.4	0.28
8MXT-1280-36	160	1280	50.4	0.48
8MXT-1280-62	160	1280	50.4	0.82
8MXT-1440-12	180	1440	56.7	0.18
8MXT-1440-21	180	1440	56.7	0.31
8MXT-1440-36	180	1440	56.7	0.54
8MXT-1440-62	180	1440	56.7	0.92
8MXT-1600-12	200	1600	63.0	0.20
8MXT-1600-21	200	1600	63.0	0.35
8MXT-1600-36	200	1600	63.0	0.60
8MXT-1600-62	200	1600	63.0	1.03
8MXT-1760-12	220	1760	69.3	0.22
8MXT-1760-21	220	1760	69.3	0.38
8MXT-1760-36	220	1760	69.3	0.66
8MXT-1760-62	220	1760	69.3	1.13
8MXT-1792-12	224	1792	70.6	0.22
8MXT-1792-21	224	1792	70.6	0.39
8MXT-1792-36	224	1792	70.6	0.67
8MXT-1792-62	224	1792	70.6	1.15
8MXT-2000-12	250	2000	78.7	0.25
8MXT-2000-21	250	2000	78.7	0.43
8MXT-2000-36	250	2000	78.7	0.74
8MXT-2000-62	250	2000	78.7	1.28
8MXT-2200-12	275	2200	86.6	0.27
8MXT-2200-21	275	2200	86.6	0.48

Synchronous Belts

Panther[®]XT

Synchronous Drive Belt

Panther[®]XT Part Numbers

Part Number	Number Of Teeth	Pitch Length		Weight (lbs)
		(mm)	(in)	
8MXT Pitch – Recommended Sprockets: MPC Sprockets – MPB, Taper Bushed (8mm)				
8MXT-2200-36	275	2200	86.6	0.82
8MXT-2200-62	275	2200	86.6	1.41
8MXT-2240-12	280	2240	88.2	0.28
8MXT-2240-21	280	2240	88.2	0.49
8MXT-2240-36	280	2240	88.2	0.83
8MXT-2240-62	280	2240	88.2	1.44
8MXT-2400-12	300	2400	94.5	0.30
8MXT-2400-21	300	2400	94.5	0.52
8MXT-2400-36	300	2400	94.5	0.89
8MXT-2400-62	300	2400	94.5	1.54
8MXT-2520-12	315	2520	99.2	0.31
8MXT-2520-21	315	2520	99.2	0.55
8MXT-2520-36	315	2520	99.2	0.94
8MXT-2520-62	315	2520	99.2	1.62
8MXT-2600-12	325	2600	102.4	0.32
8MXT-2600-21	325	2600	102.4	0.56
8MXT-2600-36	325	2600	102.4	0.97
8MXT-2600-62	325	2600	102.4	1.67
8MXT-2800-12	350	2800	110.2	0.35
8MXT-2800-21	350	2800	110.2	0.61
8MXT-2800-36	350	2800	110.2	1.04
8MXT-2800-62	350	2800	110.2	1.79
8MXT-2840-12	355	2840	111.8	0.35
8MXT-2840-21	355	2840	111.8	0.62
8MXT-2840-36	355	2840	111.8	1.06
8MXT-2840-62	355	2840	111.8	1.82
8MXT-3048-12	381	3048	120.0	0.38
8MXT-3048-21	381	3048	120.0	0.66
8MXT-3048-36	381	3048	120.0	1.13
8MXT-3048-62	381	3048	120.0	1.95
8MXT-3200-12	400	3200	126.0	0.40
8MXT-3200-21	400	3200	126.0	0.69
8MXT-3200-36	400	3200	126.0	1.19

Part Number	Number Of Teeth	Pitch Length		Weight (lbs)
		(mm)	(in)	
8MXT Pitch – Recommended Sprockets: MPC Sprockets – MPB, Taper Bushed (8mm)				
8MXT-3200-62	400	3200	126.0	2.05
8MXT-3280-12	410	3280	129.1	0.41
8MXT-3280-21	410	3280	129.1	0.71
8MXT-3280-36	410	3280	129.1	1.22
8MXT-3280-62	410	3280	129.1	2.10
8MXT-3600-12	450	3600	141.7	0.45
8MXT-3600-21	450	3600	141.7	0.78
8MXT-3600-36	450	3600	141.7	1.34
8MXT-3600-62	450	3600	141.7	2.31
8MXT-4000-12	500	4000	157.5	0.50
8MXT-4000-21	500	4000	157.5	0.87
8MXT-4000-36	500	4000	157.5	1.49
8MXT-4000-62	500	4000	157.5	2.56
8MXT-4400-12	550	4400	173.2	0.55
8MXT-4400-21	550	4400	173.2	0.96
8MXT-4400-36	550	4400	173.2	1.64
8MXT-4400-62	550	4400	173.2	2.82
8MXT-4480-12	560	4480	176.4	0.56
8MXT-4480-21	560	4480	176.4	0.97
8MXT-4480-36	560	4480	176.4	1.67
8MXT-4480-62	560	4480	176.4	2.87
14MXT Pitch – Recommended Sprockets: MPC Sprockets – MPB, Taper Bushed (14mm)				
14MXT-994-20	71	994	39.1	0.36
14MXT-994-37	71	994	39.1	0.67
14MXT-994-68	71	994	39.1	1.24
14MXT-994-90	71	994	39.1	1.64
14MXT-994-125	71	994	39.1	2.28
14MXT-1120-20	80	1120	44.1	0.41
14MXT-1120-37	80	1120	44.1	0.76
14MXT-1120-68	80	1120	44.1	1.40
14MXT-1120-90	80	1120	44.1	1.85
14MXT-1120-125	80	1120	44.1	2.57

Panther[®]XT

Synchronous Drive Belt

Part Number Example: **14MXT-1400-90** = **14M** **XT** - **1400** - **90**

Tooth Pitch
PantherXT Construction
Pitch Length (millimeters)
Width (millimeters)

Part Number	Number Of Teeth	Pitch Length		Weight (lbs)
		(mm)	(in)	
14MXT Pitch – Recommended Sprockets: MPC Sprockets – MPB, Taper Bushed (14mm)				
14MXT-1190-20	85	1190	46.9	0.44
14MXT-1190-37	85	1190	46.9	0.81
14MXT-1190-68	85	1190	46.9	1.48
14MXT-1190-90	85	1190	46.9	1.96
14MXT-1190-125	85	1190	46.9	2.73
14MXT-1260-20	90	1260	49.6	0.46
14MXT-1260-37	90	1260	49.6	0.86
14MXT-1260-68	90	1260	49.6	1.57
14MXT-1260-90	90	1260	49.6	2.08
14MXT-1260-125	90	1260	49.6	2.89
14MXT-1400-20	100	1400	55.1	0.51
14MXT-1400-37	100	1400	55.1	0.95
14MXT-1400-68	100	1400	55.1	1.75
14MXT-1400-90	100	1400	55.1	2.31
14MXT-1400-125	100	1400	55.1	3.21
14MXT-1568-20	112	1568	61.7	0.58
14MXT-1568-37	112	1568	61.7	1.06
14MXT-1568-68	112	1568	61.7	1.96
14MXT-1568-90	112	1568	61.7	2.59
14MXT-1568-125	112	1568	61.7	3.60
14MXT-1610-20	115	1610	63.4	0.59
14MXT-1610-37	115	1610	63.4	1.09
14MXT-1610-68	115	1610	63.4	2.01
14MXT-1610-90	115	1610	63.4	2.66
14MXT-1610-125	115	1610	63.4	3.69
14MXT-1750-20	125	1750	68.9	0.64
14MXT-1750-37	125	1750	68.9	1.19
14MXT-1750-68	125	1750	68.9	2.18
14MXT-1750-90	125	1750	68.9	2.89
14MXT-1750-125	125	1750	68.9	4.01
14MXT-1890-20	135	1890	74.4	0.69
14MXT-1890-37	135	1890	74.4	1.28
14MXT-1890-68	135	1890	74.4	2.36

Part Number	Number Of Teeth	Pitch Length		Weight (lbs)
		(mm)	(in)	
14MXT Pitch – Recommended Sprockets: MPC Sprockets – MPB, Taper Bushed (14mm)				
14MXT-1890-90	135	1890	74.4	3.12
14MXT-1890-125	135	1890	74.4	4.33
14MXT-1960-20	140	1960	77.2	0.72
14MXT-1960-37	140	1960	77.2	1.33
14MXT-1960-68	140	1960	77.2	2.44
14MXT-1960-90	140	1960	77.2	3.24
14MXT-1960-125	140	1960	77.2	4.49
14MXT-2100-20	150	2100	82.7	0.77
14MXT-2100-37	150	2100	82.7	1.43
14MXT-2100-68	150	2100	82.7	2.62
14MXT-2100-90	150	2100	82.7	3.47
14MXT-2100-125	150	2100	82.7	4.81
14MXT-2240-20	160	2240	88.2	0.82
14MXT-2240-37	160	2240	88.2	1.52
14MXT-2240-68	160	2240	88.2	2.79
14MXT-2240-90	160	2240	88.2	3.70
14MXT-2240-125	160	2240	88.2	5.14
14MXT-2310-20	165	2310	90.9	0.85
14MXT-2310-37	165	2310	90.9	1.57
14MXT-2310-68	165	2310	90.9	2.88
14MXT-2310-90	165	2310	90.9	3.81
14MXT-2310-125	165	2310	90.9	5.30
14MXT-2380-20	170	2380	93.7	0.87
14MXT-2380-37	170	2380	93.7	1.62
14MXT-2380-68	170	2380	93.7	2.97
14MXT-2380-90	170	2380	93.7	3.93
14MXT-2380-125	170	2380	93.7	5.46
14MXT-2450-20	175	2450	96.5	0.90
14MXT-2450-37	175	2450	96.5	1.66
14MXT-2450-68	175	2450	96.5	3.06
14MXT-2450-90	175	2450	96.5	4.04
14MXT-2450-125	175	2450	96.5	5.62
14MXT-2520-20	180	2520	99.2	0.92

Synchronous Belts

Panther[®]XT

Synchronous Drive Belt

Panther[®]XT Part Numbers

Part Number Example: **14MXT-2520-90 =**
14M **XT** - **2520** - **90**
Tooth Pitch PantherXT Pitch Length (millimeters) Width (millimeters)

Part Number	Number Of Teeth	Pitch Length		Weight (lbs)
		(mm)	(in)	
14MXT Pitch – Recommended Sprockets: MPC Sprockets – MPB, Taper Bushed (14mm)				
14MXT-2520-37	180	2520	99.2	1.71
14MXT-2520-68	180	2520	99.2	3.14
14MXT-2520-90	180	2520	99.2	4.16
14MXT-2520-125	180	2520	99.2	5.78
14MXT-2590-20	185	2590	102.0	0.95
14MXT-2590-37	185	2590	102.0	1.76
14MXT-2590-68	185	2590	102.0	3.23
14MXT-2590-90	185	2590	102.0	4.28
14MXT-2590-125	185	2590	102.0	5.94
14MXT-2660-20	190	2660	104.7	0.98
14MXT-2660-37	190	2660	104.7	1.81
14MXT-2660-68	190	2660	104.7	3.32
14MXT-2660-90	190	2660	104.7	4.39
14MXT-2660-125	190	2660	104.7	6.10
14MXT-2800-20	200	2800	110.2	1.03
14MXT-2800-37	200	2800	110.2	1.90
14MXT-2800-68	200	2800	110.2	3.49
14MXT-2800-90	200	2800	110.2	4.62
14MXT-2800-125	200	2800	110.2	6.42
14MXT-3136-20	224	3136	123.5	1.15
14MXT-3136-37	224	3136	123.5	2.13
14MXT-3136-68	224	3136	123.5	3.91
14MXT-3136-90	224	3136	123.5	5.18
14MXT-3136-125	224	3136	123.5	7.19
14MXT-3304-20	236	3304	130.1	1.21
14MXT-3304-37	236	3304	130.1	2.24
14MXT-3304-68	236	3304	130.1	4.12
14MXT-3304-90	236	3304	130.1	5.45
14MXT-3304-125	236	3304	130.1	7.58
14MXT-3360-20	240	3360	132.3	1.23
14MXT-3360-37	240	3360	132.3	2.28
14MXT-3360-68	240	3360	132.3	4.19
14MXT-3360-90	240	3360	132.3	5.55

Part Number	Number Of Teeth	Pitch Length		Weight (lbs)
		(mm)	(in)	
14MXT Pitch – Recommended Sprockets: MPC Sprockets – MPB, Taper Bushed (14mm)				
14MXT-3360-125	240	3360	132.3	7.70
14MXT-3500-20	250	3500	137.8	1.28
14MXT-3500-37	250	3500	137.8	2.38
14MXT-3500-68	250	3500	137.8	4.37
14MXT-3500-90	250	3500	137.8	5.78
14MXT-3500-125	250	3500	137.8	8.02
14MXT-3850-20	275	3850	151.6	1.41
14MXT-3850-37	275	3850	151.6	2.61
14MXT-3850-68	275	3850	151.6	4.80
14MXT-3850-90	275	3850	151.6	6.36
14MXT-3850-125	275	3850	151.6	8.83
14MXT-3920-20	280	3920	154.3	1.44
14MXT-3920-37	280	3920	154.3	2.66
14MXT-3920-68	280	3920	154.3	4.89
14MXT-3920-90	280	3920	154.3	6.47
14MXT-3920-125	280	3920	154.3	8.99
14MXT-4326-20	309	4326	170.3	1.59
14MXT-4326-37	309	4326	170.3	2.94
14MXT-4326-68	309	4326	170.3	5.40
14MXT-4326-90	309	4326	170.3	7.14
14MXT-4326-125	309	4326	170.3	9.92
14MXT-4410-20	315	4410	173.6	1.62
14MXT-4410-37	315	4410	173.6	2.99
14MXT-4410-68	315	4410	173.6	5.50
14MXT-4410-90	315	4410	173.6	7.28
14MXT-4410-125	315	4410	173.6	10.11

Panther[®]XT

Synchronous Drive Belt

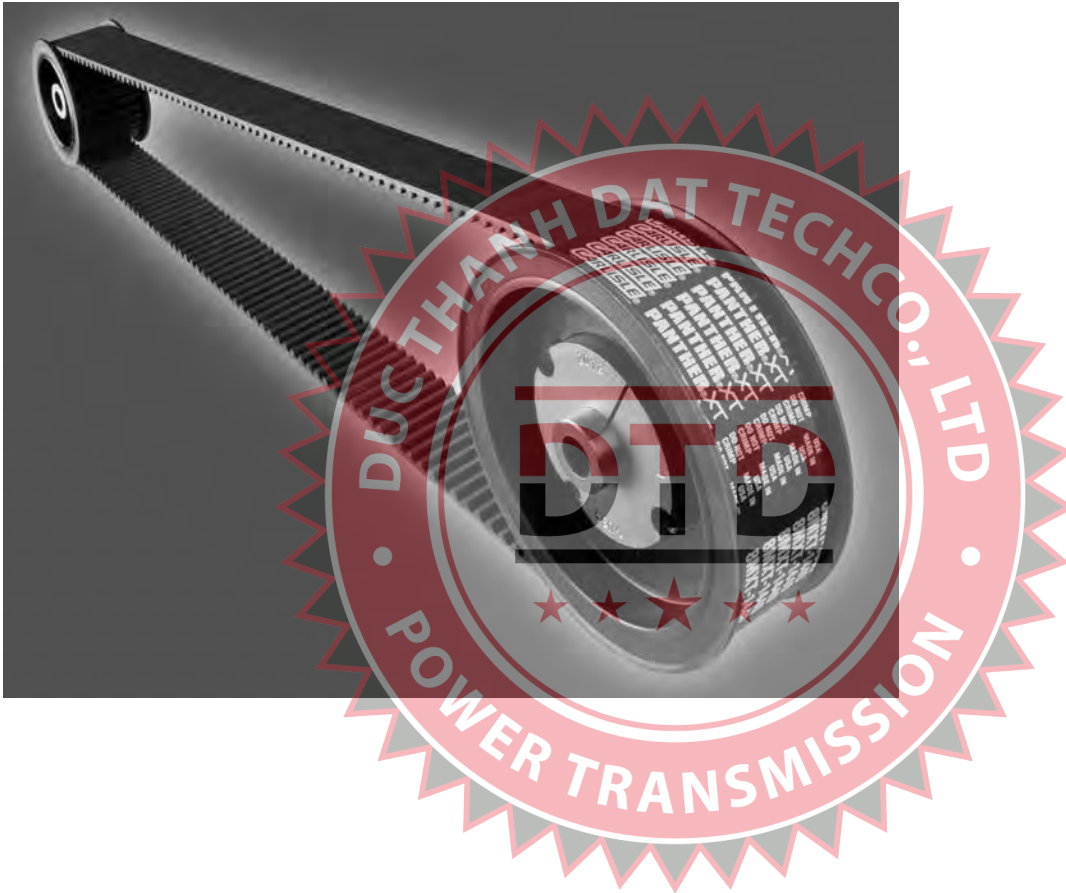

Synchronous Belts

Panther[®]

Synchronous Drive Belt



Panther[®]

Synchronous Drive Belt

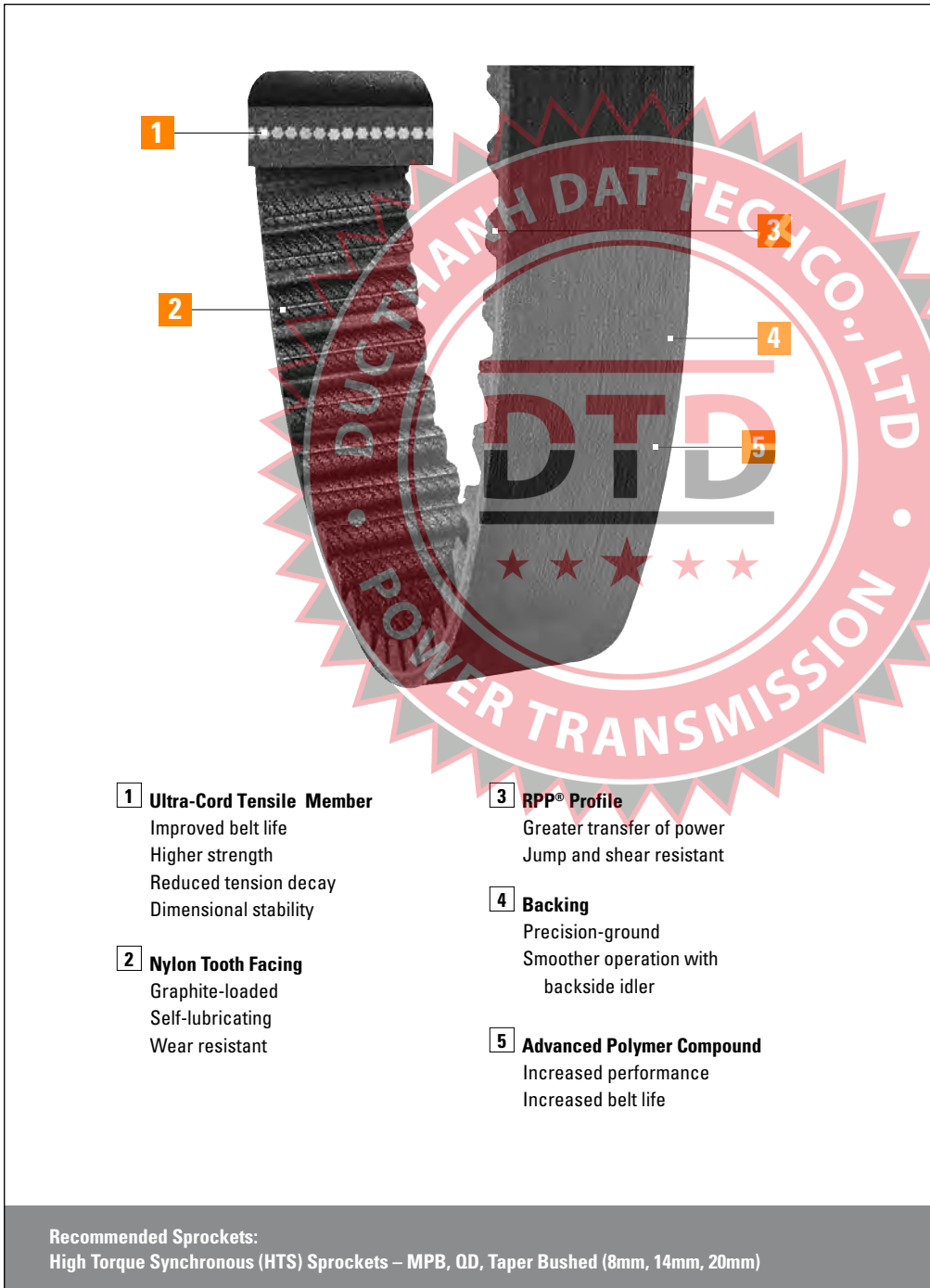

- 1 Ultra-Cord Tensile Member**
Improved belt life
Higher strength
Reduced tension decay
Dimensional stability
- 2 Nylon Tooth Facing**
Graphite-loaded
Self-lubricating
Wear resistant

- 3 RPP[®] Profile**
Greater transfer of power
Jump and shear resistant
- 4 Backing**
Precision-ground
Smoother operation with
backside idler
- 5 Advanced Polymer Compound**
Increased performance
Increased belt life

Recommended Sprockets:
High Torque Synchronous (HTS) Sprockets – MPB, OD, Taper Bushed (8mm, 14mm, 20mm)

- Ultra-Cord[®] tensile member
- Advanced polymer compound
- Maintenance-free
- Energy efficient
- Applications:**
Conveyors
Blowers
Packaging equipment
Machine tools
Industrial machinery
& More

Synchronous Belts

Panther®

Synchronous Drive Belt

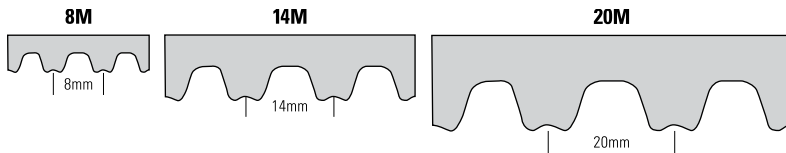

Panther® is designed to improve performance and drive life while reducing maintenance and downtime.

The energy efficient Panther®

offers higher torque capacity than the Carlisle® Synchro-Cog® HT and conventional synchronous belts.

- **Strong** – Panther shrugs off shock loads. Designed with Ultra-Cord, a non-aramid fiber tensile member that delivers strength and dimensional stability.
- **Resilient** – Uniquely engineered teeth are made of high performance polychloroprene, an advanced polymer compound which increases both the strength and abrasion resistance of the teeth. The RPP® profile offers superior performance in RPP, HTS and PGGT2® sprockets as well as HPPD, Hawk Pd® and HTD® sprockets.
- **Energy Efficient** – Panther performs at 98-99% operating efficiency for reduced energy consumption.
- **Panther Power** – Panther offers higher power ratings than conventional rubber synchronous belts. Available in 8, 14 and 20mm pitches.



Hawk Pd® is a registered trademark of Veyance Technologies, Inc. PGGT2® and HTD® are registered trademarks of Gates Corporation.

Panther® Synchronous Drive Belt

Panther® Part Numbers

Part Number Example: **1400-8MPT-50** = **1400** - **8M** **PT** - **50**
Pitch Length (millimeters) Tooth Pitch Panther Construction (RPP tooth profile) Width (millimeters)

Part Number	Number Of Teeth	Pitch Length		Weight (lbs)
		(mm)	(in)	
8M Pitch – High Torque Synchronous (HTS) Sprockets: MPB, OD, Taper Bushed (8mm)				
480-8MPT-12	60	480	18.9	0.07
480-8MPT-20	60	480	18.9	0.12
480-8MPT-22	60	480	18.9	0.13
480-8MPT-30	60	480	18.9	0.17
480-8MPT-35	60	480	18.9	0.20
480-8MPT-50	60	480	18.9	0.29
480-8MPT-60	60	480	18.9	0.35
480-8MPT-85	60	480	18.9	0.49
560-8MPT-12	70	560	22.0	0.08
560-8MPT-20	70	560	22.0	0.14
560-8MPT-22	70	560	22.0	0.15
560-8MPT-30	70	560	22.0	0.20
560-8MPT-35	70	560	22.0	0.24
560-8MPT-50	70	560	22.0	0.34
560-8MPT-60	70	560	22.0	0.41
560-8MPT-85	70	560	22.0	0.57
600-8MPT-12	75	600	23.6	0.09
600-8MPT-20	75	600	23.6	0.14
600-8MPT-22	75	600	23.6	0.16
600-8MPT-30	75	600	23.6	0.22
600-8MPT-35	75	600	23.6	0.25
600-8MPT-50	75	600	23.6	0.36
600-8MPT-60	75	600	23.6	0.43
600-8MPT-85	75	600	23.6	0.61
640-8MPT-12	80	640	25.2	0.09
640-8MPT-20	80	640	25.2	0.15
640-8MPT-22	80	640	25.2	0.17
640-8MPT-30	80	640	25.2	0.23
640-8MPT-35	80	640	25.2	0.27
640-8MPT-50	80	640	25.2	0.39
640-8MPT-60	80	640	25.2	0.46
640-8MPT-85	80	640	25.2	0.66
720-8MPT-12	90	720	28.3	0.10

Part Number	Number Of Teeth	Pitch Length		Weight (lbs)
		(mm)	(in)	
8M Pitch – High Torque Synchronous (HTS) Sprockets: MPB, OD, Taper Bushed (8mm)				
720-8MPT-20	90	720	28.3	0.17
720-8MPT-22	90	720	28.3	0.19
720-8MPT-30	90	720	28.3	0.26
720-8MPT-35	90	720	28.3	0.30
720-8MPT-50	90	720	28.3	0.43
720-8MPT-60	90	720	28.3	0.52
720-8MPT-85	90	720	28.3	0.74
800-8MPT-12	100	800	31.5	0.12
800-8MPT-20	100	800	31.5	0.19
800-8MPT-22	100	800	31.5	0.21
800-8MPT-30	100	800	31.5	0.29
800-8MPT-35	100	800	31.5	0.34
800-8MPT-50	100	800	31.5	0.48
800-8MPT-60	100	800	31.5	0.58
800-8MPT-85	100	800	31.5	0.82
880-8MPT-12	110	880	34.6	0.13
880-8MPT-20	110	880	34.6	0.21
880-8MPT-22	110	880	34.6	0.23
880-8MPT-30	110	880	34.6	0.32
880-8MPT-35	110	880	34.6	0.37
880-8MPT-50	110	880	34.6	0.53
880-8MPT-60	110	880	34.6	0.64
880-8MPT-85	110	880	34.6	0.90
896-8MPT-12	112	896	35.3	0.13
896-8MPT-20	112	896	35.3	0.22
896-8MPT-22	112	896	35.3	0.24
896-8MPT-30	112	896	35.3	0.32
896-8MPT-35	112	896	35.3	0.38
896-8MPT-50	112	896	35.3	0.54
896-8MPT-60	112	896	35.3	0.65
896-8MPT-85	112	896	35.3	0.92
920-8MPT-12	115	920	36.2	0.13
920-8MPT-20	115	920	36.2	0.22

Synchronous Belts

Panther®

Synchronous Drive Belt

Panther® Part Numbers

Part Number	Number Of Teeth	Pitch Length		Weight (lbs)
		(mm)	(in)	
8M Pitch – High Torque Synchronous (HTS) Sprockets: MPB, QD, Taper Bushed (8mm)				
920-8MPT-22	115	920	36.2	0.24
920-8MPT-30	115	920	36.2	0.33
920-8MPT-35	115	920	36.2	0.39
920-8MPT-50	115	920	36.2	0.55
920-8MPT-60	115	920	36.2	0.67
920-8MPT-85	115	920	36.2	0.94
960-8MPT-12	120	960	37.8	0.14
960-8MPT-20	120	960	37.8	0.23
960-8MPT-22	120	960	37.8	0.25
960-8MPT-30	120	960	37.8	0.35
960-8MPT-35	120	960	37.8	0.41
960-8MPT-50	120	960	37.8	0.58
960-8MPT-60	120	960	37.8	0.69
960-8MPT-85	120	960	37.8	0.98
1000-8MPT-12	125	1000	39.4	0.14
1000-8MPT-20	125	1000	39.4	0.24
1000-8MPT-22	125	1000	39.4	0.27
1000-8MPT-30	125	1000	39.4	0.36
1000-8MPT-35	125	1000	39.4	0.42
1000-8MPT-50	125	1000	39.4	0.60
1000-8MPT-60	125	1000	39.4	0.72
1000-8MPT-85	125	1000	39.4	1.02
1040-8MPT-12	130	1040	40.9	0.15
1040-8MPT-20	130	1040	40.9	0.25
1040-8MPT-22	130	1040	40.9	0.28
1040-8MPT-30	130	1040	40.9	0.38
1040-8MPT-35	130	1040	40.9	0.44
1040-8MPT-50	130	1040	40.9	0.63
1040-8MPT-60	130	1040	40.9	0.75
1040-8MPT-85	130	1040	40.9	1.07
1120-8MPT-12	140	1120	44.1	0.16
1120-8MPT-20	140	1120	44.1	0.27
1120-8MPT-22	140	1120	44.1	0.30

Part Number	Number Of Teeth	Pitch Length		Weight (lbs)
		(mm)	(in)	
8M Pitch – High Torque Synchronous (HTS) Sprockets: MPB, QD, Taper Bushed (8mm)				
1120-8MPT-30	140	1120	44.1	0.41
1120-8MPT-35	140	1120	44.1	0.47
1120-8MPT-50	140	1120	44.1	0.68
1120-8MPT-60	140	1120	44.1	0.81
1120-8MPT-85	140	1120	44.1	1.15
1152-8MPT-12	144	1152	45.4	0.17
1152-8MPT-20	144	1152	45.4	0.28
1152-8MPT-22	144	1152	45.4	0.31
1152-8MPT-30	144	1152	45.4	0.42
1152-8MPT-35	144	1152	45.4	0.49
1152-8MPT-50	144	1152	45.4	0.69
1152-8MPT-60	144	1152	45.4	0.83
1152-8MPT-85	144	1152	45.4	1.18
1200-8MPT-12	150	1200	47.2	0.17
1200-8MPT-20	150	1200	47.2	0.29
1200-8MPT-22	150	1200	47.2	0.32
1200-8MPT-30	150	1200	47.2	0.43
1200-8MPT-35	150	1200	47.2	0.51
1200-8MPT-50	150	1200	47.2	0.72
1200-8MPT-60	150	1200	47.2	0.87
1200-8MPT-85	150	1200	47.2	1.23
1224-8MPT-12	153	1224	48.2	0.18
1224-8MPT-20	153	1224	48.2	0.30
1224-8MPT-22	153	1224	48.2	0.32
1224-8MPT-30	153	1224	48.2	0.44
1224-8MPT-35	153	1224	48.2	0.52
1224-8MPT-50	153	1224	48.2	0.74
1224-8MPT-60	153	1224	48.2	0.89
1224-8MPT-85	153	1224	48.2	1.25
1248-8MPT-12	156	1248	49.1	0.18
1248-8MPT-20	156	1248	49.1	0.30
1248-8MPT-22	156	1248	49.1	0.33
1248-8MPT-30	156	1248	49.1	0.45

Panther®

Synchronous Drive Belt

Part Number Example: **1400-8MPT-50** = **1400** - **8M** **PT** - **50**
Pitch Length (millimeters) Tooth Pitch Panther Construction (RPP tooth profile) Width (millimeters)

Part Number	Number Of Teeth	Pitch Length		Weight (lbs)
		(mm)	(in)	
8M Pitch – High Torque Synchronous (HTS) Sprockets: MPB, OD, Taper Bushed (8mm)				
1248-8MPT-35	156	1248	49.1	0.53
1248-8MPT-50	156	1248	49.1	0.75
1248-8MPT-60	156	1248	49.1	0.90
1248-8MPT-85	156	1248	49.1	1.28
1280-8MPT-12	160	1280	50.4	0.19
1280-8MPT-20	160	1280	50.4	0.31
1280-8MPT-22	160	1280	50.4	0.34
1280-8MPT-30	160	1280	50.4	0.46
1280-8MPT-35	160	1280	50.4	0.54
1280-8MPT-50	160	1280	50.4	0.77
1280-8MPT-60	160	1280	50.4	0.93
1280-8MPT-85	160	1280	50.4	1.31
1360-8MPT-12	170	1360	53.5	0.20
1360-8MPT-20	170	1360	53.5	0.33
1360-8MPT-22	170	1360	53.5	0.36
1360-8MPT-30	170	1360	53.5	0.49
1360-8MPT-35	170	1360	53.5	0.57
1360-8MPT-50	170	1360	53.5	0.82
1360-8MPT-60	170	1360	53.5	0.98
1360-8MPT-85	170	1360	53.5	1.39
1400-8MPT-12	175	1400	55.1	0.20
1400-8MPT-20	175	1400	55.1	0.34
1400-8MPT-22	175	1400	55.1	0.37
1400-8MPT-30	175	1400	55.1	0.51
1400-8MPT-35	175	1400	55.1	0.59
1400-8MPT-50	175	1400	55.1	0.84
1400-8MPT-60	175	1400	55.1	1.01
1400-8MPT-85	175	1400	55.1	1.43
1440-8MPT-12	180	1440	56.7	0.21
1440-8MPT-20	180	1440	56.7	0.35
1440-8MPT-22	180	1440	56.7	0.38
1440-8MPT-30	180	1440	56.7	0.52
1440-8MPT-35	180	1440	56.7	0.61

Part Number	Number Of Teeth	Pitch Length		Weight (lbs)
		(mm)	(in)	
8M Pitch – High Torque Synchronous (HTS) Sprockets: MPB, OD, Taper Bushed (8mm)				
1440-8MPT-50	180	1440	56.7	0.87
1440-8MPT-60	180	1440	56.7	1.04
1440-8MPT-85	180	1440	56.7	1.48
1600-8MPT-12	200	1600	63.0	0.23
1600-8MPT-20	200	1600	63.0	0.39
1600-8MPT-22	200	1600	63.0	0.42
1600-8MPT-30	200	1600	63.0	0.58
1600-8MPT-35	200	1600	63.0	0.68
1600-8MPT-50	200	1600	63.0	0.96
1600-8MPT-60	200	1600	63.0	1.16
1600-8MPT-85	200	1600	63.0	1.64
1760-8MPT-12	220	1760	69.3	0.25
1760-8MPT-20	220	1760	69.3	0.42
1760-8MPT-22	220	1760	69.3	0.47
1760-8MPT-30	220	1760	69.3	0.64
1760-8MPT-35	220	1760	69.3	0.74
1760-8MPT-50	220	1760	69.3	1.06
1760-8MPT-60	220	1760	69.3	1.27
1760-8MPT-85	220	1760	69.3	1.80
1800-8MPT-12	225	1800	70.9	0.26
1800-8MPT-20	225	1800	70.9	0.43
1800-8MPT-22	225	1800	70.9	0.48
1800-8MPT-30	225	1800	70.9	0.65
1800-8MPT-35	225	1800	70.9	0.76
1800-8MPT-50	225	1800	70.9	1.09
1800-8MPT-60	225	1800	70.9	1.30
1800-8MPT-85	225	1800	70.9	1.84
1904-8MPT-12	238	1904	75.0	0.28
1904-8MPT-20	238	1904	75.0	0.46
1904-8MPT-22	238	1904	75.0	0.51
1904-8MPT-30	238	1904	75.0	0.69
1904-8MPT-35	238	1904	75.0	0.80
1904-8MPT-50	238	1904	75.0	1.15

Synchronous Belts

Panther®

Synchronous Drive Belt

Panther®

Part Numbers

Part Number	Number Of Teeth	Pitch Length		Weight (lbs)
		(mm)	(in)	
8M Pitch – High Torque Synchronous (HTS) Sprockets: MPB, QD, Taper Bushed (8mm)				
1904-8MPT-60	238	1904	75.0	1.38
1904-8MPT-85	238	1904	75.0	1.95
2000-8MPT-12	250	2000	78.7	0.29
2000-8MPT-20	250	2000	78.7	0.48
2000-8MPT-22	250	2000	78.7	0.53
2000-8MPT-30	250	2000	78.7	0.72
2000-8MPT-35	250	2000	78.7	0.84
2000-8MPT-50	250	2000	78.7	1.21
2000-8MPT-60	250	2000	78.7	1.45
2000-8MPT-85	250	2000	78.7	2.05
2104-8MPT-12	263	2104	82.8	0.30
2104-8MPT-20	263	2104	82.8	0.51
2104-8MPT-22	263	2104	82.8	0.56
2104-8MPT-30	263	2104	82.8	0.76
2104-8MPT-35	263	2104	82.8	0.89
2104-8MPT-50	263	2104	82.8	1.27
2104-8MPT-60	263	2104	82.8	1.52
2104-8MPT-85	263	2104	82.8	2.16
2200-8MPT-12	275	2200	86.6	0.32
2200-8MPT-20	275	2200	86.6	0.53
2200-8MPT-22	275	2200	86.6	0.58
2200-8MPT-30	275	2200	86.6	0.80
2200-8MPT-35	275	2200	86.6	0.93
2200-8MPT-50	275	2200	86.6	1.33
2200-8MPT-60	275	2200	86.6	1.59
2200-8MPT-85	275	2200	86.6	2.25
2240-8MPT-12	280	2240	88.2	0.32
2240-8MPT-20	280	2240	88.2	0.54
2240-8MPT-22	280	2240	88.2	0.59
2240-8MPT-30	280	2240	88.2	0.81
2240-8MPT-35	280	2240	88.2	0.95
2240-8MPT-50	280	2240	88.2	1.35
2240-8MPT-60	280	2240	88.2	1.62

Part Number	Number Of Teeth	Pitch Length		Weight (lbs)
		(mm)	(in)	
8M Pitch – High Torque Synchronous (HTS) Sprockets: MPB, QD, Taper Bushed (8mm)				
2240-8MPT-85	280	2240	88.2	2.30
2400-8MPT-12	300	2400	94.5	0.35
2400-8MPT-20	300	2400	94.5	0.58
2400-8MPT-22	300	2400	94.5	0.64
2400-8MPT-30	300	2400	94.5	0.87
2400-8MPT-35	300	2400	94.5	1.01
2400-8MPT-50	300	2400	94.5	1.45
2400-8MPT-60	300	2400	94.5	1.74
2400-8MPT-85	300	2400	94.5	2.46
2600-8MPT-12	325	2600	102.4	0.38
2600-8MPT-20	325	2600	102.4	0.63
2600-8MPT-22	325	2600	102.4	0.69
2600-8MPT-30	325	2600	102.4	0.94
2600-8MPT-35	325	2600	102.4	1.10
2600-8MPT-50	325	2600	102.4	1.57
2600-8MPT-60	325	2600	102.4	1.88
2600-8MPT-85	325	2600	102.4	2.66
2800-8MPT-12	350	2800	110.2	0.41
2800-8MPT-20	350	2800	110.2	0.68
2800-8MPT-22	350	2800	110.2	0.74
2800-8MPT-30	350	2800	110.2	1.01
2800-8MPT-35	350	2800	110.2	1.18
2800-8MPT-50	350	2800	110.2	1.69
2800-8MPT-60	350	2800	110.2	2.03
2800-8MPT-85	350	2800	110.2	2.87
3048-8MPT-12	381	3048	120.0	0.44
3048-8MPT-20	381	3048	120.0	0.74
3048-8MPT-22	381	3048	120.0	0.81
3048-8MPT-30	381	3048	120.0	1.10
3048-8MPT-35	381	3048	120.0	1.29
3048-8MPT-50	381	3048	120.0	1.84
3048-8MPT-60	381	3048	120.0	2.21
3048-8MPT-85	381	3048	120.0	3.12

Panther®

Synchronous Drive Belt

Part Number Example: **2240-8MPT-85** = **2240** - **8M** **PT** - **85**
Pitch Length (millimeters) Tooth Pitch Panther Construction (RPP tooth profile) Width (millimeters)

Part Number	Number Of Teeth	Pitch Length		Weight (lbs)
		(mm)	(in)	
8M Pitch – High Torque Synchronous (HTS) Sprockets: MPB, QD, Taper Bushed (8mm)				
3280-8MPT-12	410	3280	129.1	0.47
3280-8MPT-20	410	3280	129.1	0.79
3280-8MPT-22	410	3280	129.1	0.87
3280-8MPT-30	410	3280	129.1	1.19
3280-8MPT-35	410	3280	129.1	1.38
3280-8MPT-50	410	3280	129.1	1.98
3280-8MPT-60	410	3280	129.1	2.37
3280-8MPT-85	410	3280	129.1	3.36
3600-8MPT-12	450	3600	141.7	0.52
3600-8MPT-20	450	3600	141.7	0.87
3600-8MPT-22	450	3600	141.7	0.96
3600-8MPT-30	450	3600	141.7	1.30
3600-8MPT-35	450	3600	141.7	1.52
3600-8MPT-50	450	3600	141.7	2.17
3600-8MPT-60	450	3600	141.7	2.60
3600-8MPT-85	450	3600	141.7	3.69
4400-8MPT-12	550	4400	173.2	0.64
4400-8MPT-20	550	4400	173.2	1.06
4400-8MPT-22	550	4400	173.2	1.17
4400-8MPT-30	550	4400	173.2	1.59
4400-8MPT-35	550	4400	173.2	1.86
4400-8MPT-50	550	4400	173.2	2.65
4400-8MPT-60	550	4400	173.2	3.18
4400-8MPT-85	550	4400	173.2	4.51
14M Pitch – High Torque Synchronous (HTS) Sprockets: MPB, QD, Taper Bushed (14mm)				
966-14MPT-20	69	966	38.0	0.39
966-14MPT-40	69	966	38.0	0.77
966-14MPT-42	69	966	38.0	0.81
966-14MPT-55	69	966	38.0	1.06
966-14MPT-65	69	966	38.0	1.26
966-14MPT-85	69	966	38.0	1.65
966-14MPT-90	69	966	38.0	1.74

Part Number	Number Of Teeth	Pitch Length		Weight (lbs)
		(mm)	(in)	
14M Pitch – High Torque Synchronous (HTS) Sprockets: MPB, QD, Taper Bushed (14mm)				
966-14MPT-115	69	966	38.0	2.23
966-14MPT-120	69	966	38.0	2.32
966-14MPT-170	69	966	38.0	3.29
1092-14MPT-20	78	1092	43.0	0.44
1092-14MPT-40	78	1092	43.0	0.88
1092-14MPT-42	78	1092	43.0	0.92
1092-14MPT-55	78	1092	43.0	1.20
1092-14MPT-65	78	1092	43.0	1.42
1092-14MPT-85	78	1092	43.0	1.86
1092-14MPT-90	78	1092	43.0	1.97
1092-14MPT-115	78	1092	43.0	2.52
1092-14MPT-120	78	1092	43.0	2.63
1092-14MPT-170	78	1092	43.0	3.72
1190-14MPT-20	85	1190	46.9	0.48
1190-14MPT-40	85	1190	46.9	0.95
1190-14MPT-42	85	1190	46.9	1.00
1190-14MPT-55	85	1190	46.9	1.31
1190-14MPT-65	85	1190	46.9	1.55
1190-14MPT-85	85	1190	46.9	2.03
1190-14MPT-90	85	1190	46.9	2.15
1190-14MPT-115	85	1190	46.9	2.74
1190-14MPT-120	85	1190	46.9	2.86
1190-14MPT-170	85	1190	46.9	4.05
1400-14MPT-20	100	1400	55.1	0.56
1400-14MPT-40	100	1400	55.1	1.12
1400-14MPT-42	100	1400	55.1	1.18
1400-14MPT-55	100	1400	55.1	1.54
1400-14MPT-65	100	1400	55.1	1.82
1400-14MPT-85	100	1400	55.1	2.38
1400-14MPT-90	100	1400	55.1	2.52
1400-14MPT-115	100	1400	55.1	3.23
1400-14MPT-120	100	1400	55.1	3.37
1400-14MPT-170	100	1400	55.1	4.77

Synchronous Belts

Panther®

Synchronous Drive Belt

Panther® Part Numbers

Part Number	Number Of Teeth	Pitch Length		Weight (lbs)
		(mm)	(in)	
14M Pitch – High Torque Synchronous (HTS) Sprockets: MPB, QD, Taper Bushed (14mm)				
1610-14MPT-20	115	1610	63.4	0.65
1610-14MPT-40	115	1610	63.4	1.29
1610-14MPT-42	115	1610	63.4	1.35
1610-14MPT-55	115	1610	63.4	1.77
1610-14MPT-65	115	1610	63.4	2.10
1610-14MPT-85	115	1610	63.4	2.74
1610-14MPT-90	115	1610	63.4	2.90
1610-14MPT-115	115	1610	63.4	3.71
1610-14MPT-120	115	1610	63.4	3.87
1610-14MPT-170	115	1610	63.4	5.48
1750-14MPT-20	125	1750	68.9	0.70
1750-14MPT-40	125	1750	68.9	1.40
1750-14MPT-42	125	1750	68.9	1.47
1750-14MPT-55	125	1750	68.9	1.93
1750-14MPT-65	125	1750	68.9	2.28
1750-14MPT-85	125	1750	68.9	2.98
1750-14MPT-90	125	1750	68.9	3.16
1750-14MPT-115	125	1750	68.9	4.03
1750-14MPT-120	125	1750	68.9	4.21
1750-14MPT-170	125	1750	68.9	5.96
1764-14MPT-20	126	1764	69.4	0.71
1764-14MPT-40	126	1764	69.4	1.41
1764-14MPT-42	126	1764	69.4	1.48
1764-14MPT-55	126	1764	69.4	1.94
1764-14MPT-65	126	1764	69.4	2.30
1764-14MPT-85	126	1764	69.4	3.00
1764-14MPT-90	126	1764	69.4	3.18
1764-14MPT-115	126	1764	69.4	4.06
1764-14MPT-120	126	1764	69.4	4.24
1764-14MPT-170	126	1764	69.4	6.01
1778-14MPT-20	127	1778	70.0	0.71
1778-14MPT-40	127	1778	70.0	1.43
1778-14MPT-42	127	1778	70.0	1.50

Part Number	Number Of Teeth	Pitch Length		Weight (lbs)
		(mm)	(in)	
14M Pitch – High Torque Synchronous (HTS) Sprockets: MPB, QD, Taper Bushed (14mm)				
1778-14MPT-55	127	1778	70.0	1.96
1778-14MPT-65	127	1778	70.0	2.32
1778-14MPT-85	127	1778	70.0	3.03
1778-14MPT-90	127	1778	70.0	3.21
1778-14MPT-115	127	1778	70.0	4.10
1778-14MPT-120	127	1778	70.0	4.28
1778-14MPT-170	127	1778	70.0	6.06
1792-14MPT-20	128	1792	70.6	0.72
1792-14MPT-40	128	1792	70.6	1.44
1792-14MPT-42	128	1792	70.6	1.51
1792-14MPT-55	128	1792	70.6	1.97
1792-14MPT-65	128	1792	70.6	2.33
1792-14MPT-85	128	1792	70.6	3.05
1792-14MPT-90	128	1792	70.6	3.23
1792-14MPT-115	128	1792	70.6	4.13
1792-14MPT-120	128	1792	70.6	4.31
1792-14MPT-170	128	1792	70.6	6.10
1820-14MPT-20	130	1820	71.7	0.73
1820-14MPT-40	130	1820	71.7	1.46
1820-14MPT-42	130	1820	71.7	1.53
1820-14MPT-55	130	1820	71.7	2.01
1820-14MPT-65	130	1820	71.7	2.37
1820-14MPT-85	130	1820	71.7	3.10
1820-14MPT-90	130	1820	71.7	3.28
1820-14MPT-115	130	1820	71.7	4.19
1820-14MPT-120	130	1820	71.7	4.38
1820-14MPT-170	130	1820	71.7	6.20
1848-14MPT-20	132	1848	72.8	0.74
1848-14MPT-40	132	1848	72.8	1.48
1848-14MPT-42	132	1848	72.8	1.56
1848-14MPT-55	132	1848	72.8	2.04
1848-14MPT-65	132	1848	72.8	2.41
1848-14MPT-85	132	1848	72.8	3.15

Panther® Synchronous Drive Belt

Part Number Example: **1610-14MPT-20** = **1610** - **14M** **PT** - **20**
Pitch Length (millimeters) Tooth Pitch Panther Construction (RPP tooth profile) Width (millimeters)

Part Number	Number Of Teeth	Pitch Length		Weight (lbs)
		(mm)	(in)	
14M Pitch – High Torque Synchronous (HTS) Sprockets: MPB, QD, Taper Bushed (14mm)				
1848-14MPT-90	132	1848	72.8	3.33
1848-14MPT-115	132	1848	72.8	4.26
1848-14MPT-120	132	1848	72.8	4.44
1848-14MPT-170	132	1848	72.8	6.29
1862-14MPT-20	133	1862	73.3	0.75
1862-14MPT-40	133	1862	73.3	1.49
1862-14MPT-42	133	1862	73.3	1.57
1862-14MPT-55	133	1862	73.3	2.05
1862-14MPT-65	133	1862	73.3	2.43
1862-14MPT-85	133	1862	73.3	3.17
1862-14MPT-90	133	1862	73.3	3.36
1862-14MPT-115	133	1862	73.3	4.29
1862-14MPT-120	133	1862	73.3	4.48
1862-14MPT-170	133	1862	73.3	6.34
1890-14MPT-20	135	1890	74.4	0.76
1890-14MPT-40	135	1890	74.4	1.51
1890-14MPT-42	135	1890	74.4	1.59
1890-14MPT-55	135	1890	74.4	2.08
1890-14MPT-65	135	1890	74.4	2.46
1890-14MPT-85	135	1890	74.4	3.22
1890-14MPT-90	135	1890	74.4	3.41
1890-14MPT-115	135	1890	74.4	4.36
1890-14MPT-120	135	1890	74.4	4.54
1890-14MPT-170	135	1890	74.4	6.44
1904-14MPT-20	136	1904	75.0	0.76
1904-14MPT-40	136	1904	75.0	1.53
1904-14MPT-42	136	1904	75.0	1.60
1904-14MPT-55	136	1904	75.0	2.10
1904-14MPT-65	136	1904	75.0	2.48
1904-14MPT-85	136	1904	75.0	3.24
1904-14MPT-90	136	1904	75.0	3.43
1904-14MPT-115	136	1904	75.0	4.39
1904-14MPT-120	136	1904	75.0	4.58

Part Number	Number Of Teeth	Pitch Length		Weight (lbs)
		(mm)	(in)	
14M Pitch – High Torque Synchronous (HTS) Sprockets: MPB, QD, Taper Bushed (14mm)				
1904-14MPT-170	136	1904	75.0	6.49
1960-14MPT-20	140	1960	77.2	0.79
1960-14MPT-40	140	1960	77.2	1.57
1960-14MPT-42	140	1960	77.2	1.65
1960-14MPT-55	140	1960	77.2	2.16
1960-14MPT-65	140	1960	77.2	2.55
1960-14MPT-85	140	1960	77.2	3.34
1960-14MPT-90	140	1960	77.2	3.53
1960-14MPT-115	140	1960	77.2	4.52
1960-14MPT-120	140	1960	77.2	4.71
1960-14MPT-170	140	1960	77.2	6.68
2100-14MPT-20	150	2100	82.7	0.84
2100-14MPT-40	150	2100	82.7	1.68
2100-14MPT-42	150	2100	82.7	1.77
2100-14MPT-55	150	2100	82.7	2.31
2100-14MPT-65	150	2100	82.7	2.74
2100-14MPT-85	150	2100	82.7	3.58
2100-14MPT-90	150	2100	82.7	3.79
2100-14MPT-115	150	2100	82.7	4.84
2100-14MPT-120	150	2100	82.7	5.05
2100-14MPT-170	150	2100	82.7	7.15
2310-14MPT-20	165	2310	90.9	0.93
2310-14MPT-40	165	2310	90.9	1.85
2310-14MPT-42	165	2310	90.9	1.94
2310-14MPT-55	165	2310	90.9	2.55
2310-14MPT-65	165	2310	90.9	3.01
2310-14MPT-85	165	2310	90.9	3.93
2310-14MPT-90	165	2310	90.9	4.17
2310-14MPT-115	165	2310	90.9	5.32
2310-14MPT-120	165	2310	90.9	5.55
2310-14MPT-170	165	2310	90.9	7.87
2450-14MPT-20	175	2450	96.5	0.98
2450-14MPT-40	175	2450	96.5	1.96

Synchronous Belts

Panther®

Synchronous Drive Belt

Panther®

Part Numbers

Part Number	Number Of Teeth	Pitch Length		Weight (lbs)
		(mm)	(in)	
14M Pitch – High Torque Synchronous (HTS) Sprockets: MPB, QD, Taper Bushed (14mm)				
2450-14MPT-42	175	2450	96.5	2.06
2450-14MPT-55	175	2450	96.5	2.70
2450-14MPT-65	175	2450	96.5	3.19
2450-14MPT-85	175	2450	96.5	4.17
2450-14MPT-90	175	2450	96.5	4.42
2450-14MPT-115	175	2450	96.5	5.65
2450-14MPT-120	175	2450	96.5	5.89
2450-14MPT-170	175	2450	96.5	8.35
2590-14MPT-20	185	2590	102.0	1.04
2590-14MPT-40	185	2590	102.0	2.08
2590-14MPT-42	185	2590	102.0	2.18
2590-14MPT-55	185	2590	102.0	2.85
2590-14MPT-65	185	2590	102.0	3.37
2590-14MPT-85	185	2590	102.0	4.41
2590-14MPT-90	185	2590	102.0	4.67
2590-14MPT-115	185	2590	102.0	5.97
2590-14MPT-120	185	2590	102.0	6.23
2590-14MPT-170	185	2590	102.0	8.82
2800-14MPT-20	200	2800	110.2	1.12
2800-14MPT-40	200	2800	110.2	2.24
2800-14MPT-42	200	2800	110.2	2.36
2800-14MPT-55	200	2800	110.2	3.09
2800-14MPT-65	200	2800	110.2	3.65
2800-14MPT-85	200	2800	110.2	4.77
2800-14MPT-90	200	2800	110.2	5.05
2800-14MPT-115	200	2800	110.2	6.45
2800-14MPT-120	200	2800	110.2	6.73
2800-14MPT-170	200	2800	110.2	9.54
3150-14MPT-20	225	3150	124.0	1.26
3150-14MPT-40	225	3150	124.0	2.52
3150-14MPT-42	225	3150	124.0	2.65
3150-14MPT-55	225	3150	124.0	3.47
3150-14MPT-65	225	3150	124.0	4.10

Part Number	Number Of Teeth	Pitch Length		Weight (lbs)
		(mm)	(in)	
14M Pitch – High Torque Synchronous (HTS) Sprockets: MPB, QD, Taper Bushed (14mm)				
3150-14MPT-85	225	3150	124.0	5.36
3150-14MPT-90	225	3150	124.0	5.68
3150-14MPT-115	225	3150	124.0	7.26
3150-14MPT-120	225	3150	124.0	7.57
3150-14MPT-170	225	3150	124.0	10.73
3360-14MPT-20	240	3360	132.3	1.35
3360-14MPT-40	240	3360	132.3	2.69
3360-14MPT-42	240	3360	132.3	2.83
3360-14MPT-55	240	3360	132.3	3.70
3360-14MPT-65	240	3360	132.3	4.38
3360-14MPT-85	240	3360	132.3	5.72
3360-14MPT-90	240	3360	132.3	6.06
3360-14MPT-115	240	3360	132.3	7.74
3360-14MPT-120	240	3360	132.3	8.08
3360-14MPT-170	240	3360	132.3	11.45
3500-14MPT-20	250	3500	137.8	1.40
3500-14MPT-40	250	3500	137.8	2.81
3500-14MPT-42	250	3500	137.8	2.95
3500-14MPT-55	250	3500	137.8	3.86
3500-14MPT-65	250	3500	137.8	4.56
3500-14MPT-85	250	3500	137.8	5.96
3500-14MPT-90	250	3500	137.8	6.31
3500-14MPT-115	250	3500	137.8	8.07
3500-14MPT-120	250	3500	137.8	8.42
3500-14MPT-170	250	3500	137.8	11.92
3850-14MPT-20	275	3850	151.6	1.54
3850-14MPT-40	275	3850	151.6	3.09
3850-14MPT-42	275	3850	151.6	3.24
3850-14MPT-55	275	3850	151.6	4.24
3850-14MPT-65	275	3850	151.6	5.01
3850-14MPT-85	275	3850	151.6	6.56
3850-14MPT-90	275	3850	151.6	6.94
3850-14MPT-115	275	3850	151.6	8.87

Panther® Synchronous Drive Belt

Part Number Example: **2450-14MPT-42** = **2450** - **14M** **PT** - **42**
Pitch Length (millimeters) Tooth Pitch Panther Construction (RPP tooth profile) Width (millimeters)

Part Number	Number Of Teeth	Pitch Length		Weight (lbs)
		(mm)	(in)	
14M Pitch – High Torque Synchronous (HTS) Sprockets: MPB, OD, Taper Bushed (14mm)				
3850-14MPT-120	275	3850	151.6	9.26
3850-14MPT-170	275	3850	151.6	13.11
4326-14MPT-20	309	4326	170.3	1.73
4326-14MPT-40	309	4326	170.3	3.47
4326-14MPT-42	309	4326	170.3	3.64
4326-14MPT-55	309	4326	170.3	4.77
4326-14MPT-65	309	4326	170.3	5.63
4326-14MPT-85	309	4326	170.3	7.37
4326-14MPT-90	309	4326	170.3	7.80
4326-14MPT-115	309	4326	170.3	9.97
4326-14MPT-120	309	4326	170.3	10.40
4326-14MPT-170	309	4326	170.3	14.74
4578-14MPT-20	327	4578	180.2	1.83
4578-14MPT-40	327	4578	180.2	3.67
4578-14MPT-42	327	4578	180.2	3.85
4578-14MPT-55	327	4578	180.2	5.05
4578-14MPT-65	327	4578	180.2	5.96
4578-14MPT-85	327	4578	180.2	7.80
4578-14MPT-90	327	4578	180.2	8.26
4578-14MPT-115	327	4578	180.2	10.55
4578-14MPT-120	327	4578	180.2	11.01
4578-14MPT-170	327	4578	180.2	15.59
4956-14MPT-20	354	4956	195.1	1.99
4956-14MPT-40	354	4956	195.1	3.97
4956-14MPT-42	354	4956	195.1	4.17
4956-14MPT-55	354	4956	195.1	5.46
4956-14MPT-65	354	4956	195.1	6.45
4956-14MPT-85	354	4956	195.1	8.44
4956-14MPT-90	354	4956	195.1	8.94
4956-14MPT-115	354	4956	195.1	11.42
4956-14MPT-120	354	4956	195.1	11.92
4956-14MPT-170	354	4956	195.1	16.88

Part Number	Number Of Teeth	Pitch Length		Weight (lbs)
		(mm)	(in)	
20M Pitch – High Torque Synchronous (HTS) Sprockets: MPB, OD, Taper Bushed (20mm)				
2000-20MPT-115	100	2000	78.7	7.46
2000-20MPT-170	100	2000	78.7	11.03
2000-20MPT-230	100	2000	78.7	14.92
2000-20MPT-290	100	2000	78.7	18.81
2000-20MPT-340	100	2000	78.7	22.06
2500-20MPT-115	125	2500	98.4	9.33
2500-20MPT-170	125	2500	98.4	13.79
2500-20MPT-230	125	2500	98.4	18.65
2500-20MPT-290	125	2500	98.4	23.52
2500-20MPT-340	125	2500	98.4	27.57
3400-20MPT-115	170	3400	133.9	12.68
3400-20MPT-170	170	3400	133.9	18.75
3400-20MPT-230	170	3400	133.9	25.37
3400-20MPT-290	170	3400	133.9	31.98
3400-20MPT-340	170	3400	133.9	37.50
3800-20MPT-115	190	3800	149.6	14.17
3800-20MPT-170	190	3800	149.6	20.95
3800-20MPT-230	190	3800	149.6	28.35
3800-20MPT-290	190	3800	149.6	35.75
3800-20MPT-340	190	3800	149.6	41.91
4200-20MPT-115	210	4200	165.4	15.67
4200-20MPT-170	210	4200	165.4	23.16
4200-20MPT-230	210	4200	165.4	31.33
4200-20MPT-290	210	4200	165.4	39.51
4200-20MPT-340	210	4200	165.4	46.32
4600-20MPT-115	230	4600	181.1	17.16
4600-20MPT-170	230	4600	181.1	25.37
4600-20MPT-230	230	4600	181.1	34.32
4600-20MPT-290	230	4600	181.1	43.27
4600-20MPT-340	230	4600	181.1	50.73

*Non-stock item. Minimum order quantity and/or extended lead times may apply. Contact customer service for availability.

Synchronous Belts

Panther® Sleeves



- Full factory width sleeves
- All sleeves will have the edges trimmed before shipment
- Cut sleeves cannot be accepted for return
- All weights are approximate

Timken maintains inventory of most Carlisle® sleeve sizes. Non-stock sizes will be indicated by an asterisk following the part number. Contact customer service for availability. Minimum order quantity and/or extended lead times may apply.

Occasional production inconsistencies which may render a portion of the sleeve unusable can be present as a normal part of the production process.

Each sleeve is inspected to ensure that it contains 90% or more usable product. A full width sleeve with less than 10% unusable product is considered acceptable.



Panther® Sleeve Part Numbers

Part Number	Sleeve Width (mm)	Sleeve Weight (lbs)
8M Pitch – High Torque Synchronous (HTS) Sprockets: MPB, OD, Taper Bushed (8mm)		
480-8MPT-470SL	470	2.72
560-8MPT-470SL	470	3.17
600-8MPT-470SL	470	3.40
640-8MPT-470SL	470	3.63
720-8MPT-470SL	470	4.08
800-8MPT-470SL	470	4.53
880-8MPT-470SL	470	4.99
896-8MPT-470SL	470	5.08
920-8MPT-470SL	470	5.21
960-8MPT-470SL	470	5.44
1000-8MPT-470SL	470	5.67
1040-8MPT-470SL	470	5.89
1120-8MPT-470SL	470	6.35
1152-8MPT-470SL	470	6.53
1200-8MPT-470SL	470	6.80
1224-8MPT-470SL	470	6.94
1248-8MPT-470SL	470	7.07
1280-8MPT-470SL	470	7.25
1360-8MPT-470SL	470	7.71
1400-8MPT-470SL	470	7.93
1440-8MPT-470SL	470	8.16
1600-8MPT-470SL	470	9.07
1760-8MPT-470SL	470	9.97
1800-8MPT-470SL	470	10.20
1904-8MPT-470SL	470	10.79
2000-8MPT-470SL	470	11.33
2104-8MPT-470SL	470	11.92
2200-8MPT-470SL	470	12.47
2240-8MPT-470SL	470	12.70
2400-8MPT-470SL	470	13.60
2600-8MPT-470SL	470	14.74
2800-8MPT-470SL	470	15.87
3048-8MPT-470SL	470	17.27

Part Number Example: **1400-8MPT-470SL** = **1400** - **8M** **PT** - **470** **SL**
Pitch Length (millimeters) Tooth Pitch Panther Construction (RPP tooth profile) Width (millimeters) Sleeve

Part Number	Sleeve Width (mm)	Sleeve Weight (lbs)
8M Pitch – High Torque Synchronous (HTS) Sprockets: MPB, QD, Taper Bushed (8mm)		
3280-8MPT-470SL	470	18.59
3600-8MPT-470SL	470	20.40
4400-8MPT-470SL	470	24.94
14M Pitch – High Torque Synchronous (HTS) Sprockets: MPB, QD, Taper Bushed (14mm)		
966-14MPT-470SL	470	9.10
1092-14MPT-470SL	470	10.28
1190-14MPT-470SL	470	11.21
1400-14MPT-470SL	470	13.18
1610-14MPT-470SL	470	15.16
1750-14MPT-470SL	470	16.48
1764-14MPT-470SL	470	16.61
1778-14MPT-470SL	470	16.74
1792-14MPT-470SL	470	16.88
1820-14MPT-470SL	470	17.14
1848-14MPT-470SL	470	17.40
1862-14MPT-470SL	470	17.54
1890-14MPT-470SL	470	17.80
1904-14MPT-470SL	470	17.93
1960-14MPT-470SL	470	18.46
2100-14MPT-470SL	470	19.78
2310-14MPT-470SL	470	21.75
2450-14MPT-470SL	470	23.07
2590-14MPT-470SL	470	24.39
2800-14MPT-470SL	470	26.37
3150-14MPT-470SL	470	29.67
3360-14MPT-470SL	470	31.64
3500-14MPT-470SL	470	32.96
3850-14MPT-470SL	470	36.26
4326-14MPT-470SL	470	40.74
4578-14MPT-470SL	470	43.11
4956-14MPT-540SL	540	46.67

Part Number	Sleeve Width (mm)	Sleeve Weight (lbs)
20M Pitch – High Torque Synchronous (HTS) Sprockets: MPB, QD, Taper Bushed (20mm)		
2000-20MPT-570SL	570	30.49
2500-20MPT-570SL	570	38.11
3400-20MPT-570SL	570	51.83
3800-20MPT-570SL	570	57.93
4200-20MPT-570SL	570	64.03
4600-20MPT-570SL	570	70.13

Synchro-Cog[®] HT

Synchronous Drive Belt



Synchro-Cog® HT

Synchronous Drive Belt

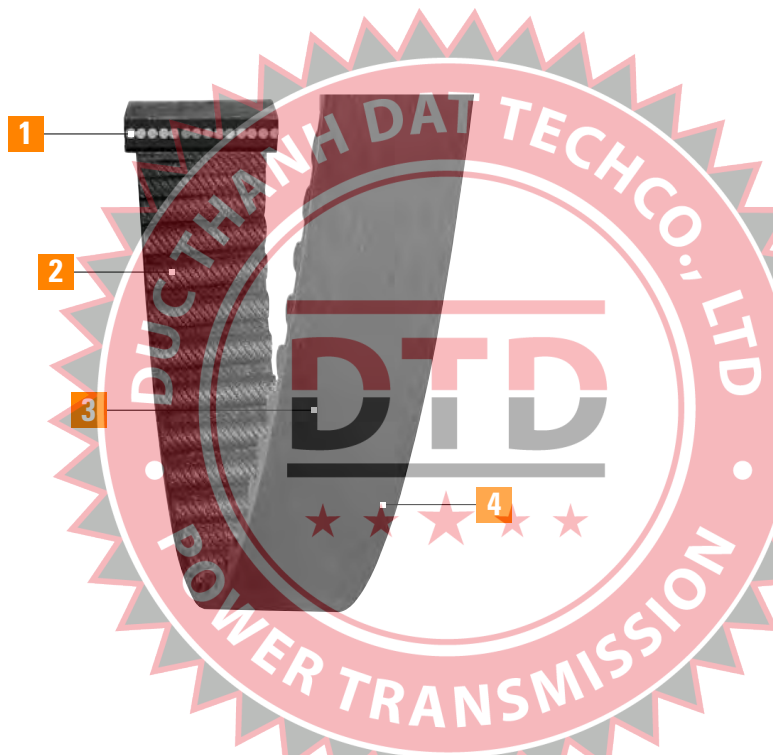

1 Fiberglass Cord

Chemically treated to assure superior length stability, maximum flexibility, and high tensile strength for heavy shock loads.

2 Fabric Cover

Resistance to tooth wear and shear from friction.

3 Teeth

Precisely formed and accurately spaced for smooth, uniform transfer of power and resistance to shear.

4 Synthetic Rubber Backing

For maximum resistance to ozone, grease, heat build-up, sunlight and flex fatigue

High torque capacity

Economical

Smaller, more compact packages

Maximum drive efficiency

HTD tooth profile

Applications:

- Blowers
- Mixers
- Machine tools
- Sewing machines
- Food processing
- Paper processing
- & More

Recommended Sprockets:

High Torque Synchronous (HTS) Sprockets – MPB, OD, Taper Bushed (3mm, 5mm, 8mm, 14mm)

Synchro-Cog® HT

Synchronous Drive Belt

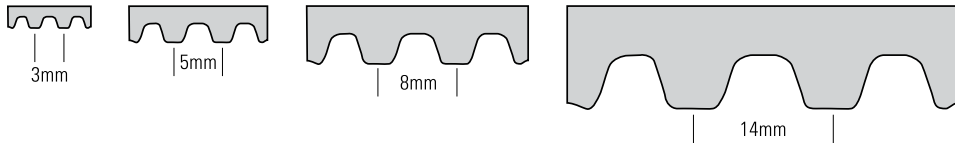

Synchro-Cog® HT delivers trouble-free power transmission with a smooth and quiet drive system.



Synchro-Cog® HT Belts are made using fiberglass cord that is treated to assure length stability, flexibility, and high tensile strength. The rubber teeth are precisely formed and accurately spaced for smooth, uniform transfer of power and shear resistance.

A specially formulated rubber backing resists ozone, grease, heat build-up, sunlight and flex-fatigue.

The nylon fabric cover is designed to provide drive efficiency and resistance to tooth wear and shear.

Synchro-Cog® HT

Synchronous Drive Belt

Synchro-Cog® HT Part Numbers

Part Number Example: **144-3M-15** = **144** - **3M** - **15**
Pitch Length (millimeters) Tooth Pitch (HTD profile) Width (millimeters)

Part Number	Number Of Teeth	Pitch Length		Weight (lbs)
		(mm)	(in)	
3M Pitch – High Torque Synchronous (HTS) Sprockets: MPB, QD, Taper Bushed (3mm)				
144-3M-6	48	144	5.7	0.005
144-3M-9	48	144	5.7	0.007
144-3M-15	48	144	5.7	0.012
150-3M-6	50	150	5.9	0.005
150-3M-9	50	150	5.9	0.007
150-3M-15	50	150	5.9	0.012
159-3M-6	53	159	6.3	0.005
159-3M-9	53	159	6.3	0.008
159-3M-15	53	159	6.3	0.013
168-3M-6	56	168	6.6	0.005
168-3M-9	56	168	6.6	0.008
168-3M-15	56	168	6.6	0.014
177-3M-6	59	177	7.0	0.006
177-3M-9	59	177	7.0	0.009
177-3M-15	59	177	7.0	0.014
180-3M-6	60	180	7.1	0.006
180-3M-9	60	180	7.1	0.009
180-3M-15	60	180	7.1	0.015
186-3M-6	62	186	7.3	0.006
186-3M-9	62	186	7.3	0.009
186-3M-15	62	186	7.3	0.015
189-3M-6	63	189	7.4	0.006
189-3M-9	63	189	7.4	0.009
189-3M-15	63	189	7.4	0.015
192-3M-6	64	192	7.6	0.006
192-3M-9	64	192	7.6	0.009
192-3M-15	64	192	7.6	0.016
201-3M-6	67	201	7.9	0.007
201-3M-9	67	201	7.9	0.010
201-3M-15	67	201	7.9	0.016
207-3M-6	69	207	8.1	0.007
207-3M-9	69	207	8.1	0.010
207-3M-15	69	207	8.1	0.017

Part Number	Number Of Teeth	Pitch Length		Weight (lbs)
		(mm)	(in)	
3M Pitch – High Torque Synchronous (HTS) Sprockets: MPB, QD, Taper Bushed (3mm)				
210-3M-6	70	210	8.3	0.007
210-3M-9	70	210	8.3	0.010
210-3M-15	70	210	8.3	0.017
213-3M-6	71	213	8.4	0.007
213-3M-9	71	213	8.4	0.010
213-3M-15	71	213	8.4	0.017
222-3M-6	74	222	8.7	0.007
222-3M-9	74	222	8.7	0.011
222-3M-15	74	222	8.7	0.018
225-3M-6	75	225	8.9	0.007
225-3M-9	75	225	8.9	0.011
225-3M-15	75	225	8.9	0.018
228-3M-6	76	228	9.0	0.007
228-3M-9	76	228	9.0	0.011
228-3M-15	76	228	9.0	0.019
234-3M-6	78	234	9.2	0.008
234-3M-9	78	234	9.2	0.011
234-3M-15	78	234	9.2	0.019
240-3M-6	80	240	9.4	0.008
240-3M-9	80	240	9.4	0.012
240-3M-15	80	240	9.4	0.019
252-3M-6	84	252	9.9	0.008
252-3M-9	84	252	9.9	0.012
252-3M-15	84	252	9.9	0.020
255-3M-6	85	255	10.0	0.008
255-3M-9	85	255	10.0	0.012
255-3M-15	85	255	10.0	0.021
264-3M-6	88	264	10.4	0.009
264-3M-9	88	264	10.4	0.013
264-3M-15	88	264	10.4	0.021
267-3M-6	89	267	10.5	0.009
267-3M-9	89	267	10.5	0.013
267-3M-15	89	267	10.5	0.022

Synchronous Belts

Synchro-Cog® HT

Synchronous Drive Belt

Synchro-Cog® HT Part Numbers

Part Number	Number Of Teeth	Pitch Length		Weight (lbs)
		(mm)	(in)	
3M Pitch – High Torque Synchronous (HTS) Sprockets: MPB, QD, Taper Bushed (3mm)				
276-3M-6	92	276	10.9	0.009
276-3M-9	92	276	10.9	0.013
276-3M-15	92	276	10.9	0.022
285-3M-6	95	285	11.2	0.009
285-3M-9	95	285	11.2	0.014
285-3M-15	95	285	11.2	0.023
300-3M-6	100	300	11.8	0.010
300-3M-9	100	300	11.8	0.015
300-3M-15	100	300	11.8	0.024
312-3M-6	104	312	12.3	0.010
312-3M-9	104	312	12.3	0.015
312-3M-15	104	312	12.3	0.025
318-3M-6	106	318	12.5	0.010
318-3M-9	106	318	12.5	0.015
318-3M-15	106	318	12.5	0.026
324-3M-6	108	324	12.8	0.011
324-3M-9	108	324	12.8	0.016
324-3M-15	108	324	12.8	0.026
330-3M-6	110	330	13.0	0.011
330-3M-9	110	330	13.0	0.016
330-3M-15	110	330	13.0	0.027
339-3M-6	113	339	13.3	0.011
339-3M-9	113	339	13.3	0.017
339-3M-15	113	339	13.3	0.028
357-3M-6	119	357	14.1	0.012
357-3M-9	119	357	14.1	0.017
357-3M-15	119	357	14.1	0.029
360-3M-6	120	360	14.2	0.012
360-3M-9	120	360	14.2	0.018
360-3M-15	120	360	14.2	0.029
363-3M-6	121	363	14.3	0.012
363-3M-9	121	363	14.3	0.018
363-3M-15	121	363	14.3	0.029

Part Number	Number Of Teeth	Pitch Length		Weight (lbs)
		(mm)	(in)	
3M Pitch – High Torque Synchronous (HTS) Sprockets: MPB, QD, Taper Bushed (3mm)				
375-3M-6	125	375	14.8	0.012
375-3M-9	125	375	14.8	0.018
375-3M-15	125	375	14.8	0.030
384-3M-6	128	384	15.1	0.012
384-3M-9	128	384	15.1	0.019
384-3M-15	128	384	15.1	0.031
390-3M-6	130	390	15.4	0.013
390-3M-9	130	390	15.4	0.019
390-3M-15	130	390	15.4	0.032
405-3M-6	135	405	15.9	0.013
405-3M-9	135	405	15.9	0.020
405-3M-15	135	405	15.9	0.033
420-3M-6	140	420	16.5	0.014
420-3M-9	140	420	16.5	0.020
420-3M-15	140	420	16.5	0.034
447-3M-6	149	447	17.6	0.015
447-3M-9	149	447	17.6	0.022
447-3M-15	149	447	17.6	0.036
456-3M-6	152	456	18.0	0.015
456-3M-9	152	456	18.0	0.022
456-3M-15	152	456	18.0	0.037
474-3M-6	158	474	18.7	0.015
474-3M-9	158	474	18.7	0.023
474-3M-15	158	474	18.7	0.038
483-3M-6	161	483	19.0	0.016
483-3M-9	161	483	19.0	0.024
483-3M-15	161	483	19.0	0.039
495-3M-6	165	495	19.5	0.016
495-3M-9	165	495	19.5	0.024
495-3M-15	165	495	19.5	0.040
501-3M-6	167	501	19.7	0.016
501-3M-9	167	501	19.7	0.024
501-3M-15	167	501	19.7	0.041

Synchro-Cog® HT

Synchronous Drive Belt

Part Number Example: **180-5M-25** = **180** - **5M** - **25**
Pitch Length (millimeters) Tooth Pitch (HTD profile) Width (millimeters)

Part Number	Number Of Teeth	Pitch Length		Weight (lbs)
		(mm)	(in)	
3M Pitch – High Torque Synchronous (HTS) Sprockets: MPB, OD, Taper Bushed (3mm)				
513-3M-6	171	513	20.2	0.017
513-3M-9	171	513	20.2	0.025
513-3M-15	171	513	20.2	0.042
522-3M-6	174	522	20.6	0.017
522-3M-9	174	522	20.6	0.025
522-3M-15	174	522	20.6	0.042
531-3M-6	177	531	20.9	0.017
531-3M-9	177	531	20.9	0.026
531-3M-15	177	531	20.9	0.043
564-3M-6	188	564	22.2	0.018
564-3M-9	188	564	22.2	0.027
564-3M-15	188	564	22.2	0.046
570-3M-6	190	570	22.4	0.019
570-3M-9	190	570	22.4	0.028
570-3M-15	190	570	22.4	0.046
582-3M-6	194	582	22.9	0.019
582-3M-9	194	582	22.9	0.028
582-3M-15	194	582	22.9	0.047
600-3M-6	200	600	23.6	0.019
600-3M-9	200	600	23.6	0.029
600-3M-15	200	600	23.6	0.049
633-3M-6	211	633	24.9	0.021
633-3M-9	211	633	24.9	0.031
633-3M-15	211	633	24.9	0.051
711-3M-6	237	711	28.0	0.023
711-3M-9	237	711	28.0	0.035
711-3M-15	237	711	28.0	0.058
735-3M-6	245	735	28.9	0.024
735-3M-9	245	735	28.9	0.036
735-3M-15	245	735	28.9	0.060
750-3M-6	250	750	29.5	0.024
750-3M-9	250	750	29.5	0.037
750-3M-15	250	750	29.5	0.061

Part Number	Number Of Teeth	Pitch Length		Weight (lbs)
		(mm)	(in)	
3M Pitch – High Torque Synchronous (HTS) Sprockets: MPB, OD, Taper Bushed (3mm)				
804-3M-6	268	804	31.7	0.026
804-3M-9	268	804	31.7	0.039
804-3M-15	268	804	31.7	0.065
1026-3M-6	342	1026	40.4	0.033
1026-3M-9	342	1026	40.4	0.050
1026-3M-15	342	1026	40.4	0.083
1401-3M-6	467	1401	55.2	0.046
1401-3M-9	467	1401	55.2	0.068
1401-3M-15	467	1401	55.2	0.114
5M Pitch – High Torque Synchronous (HTS) Sprockets: MPB, OD, Taper Bushed (5mm)				
180-5M-9	36	180	7.1	0.014
180-5M-15	36	180	7.1	0.024
180-5M-25	36	180	7.1	0.040
200-5M-9	40	200	7.9	0.016
200-5M-15	40	200	7.9	0.027
200-5M-25	40	200	7.9	0.045
210-5M-9	42	210	8.3	0.017
210-5M-15	42	210	8.3	0.028
210-5M-25	42	210	8.3	0.047
215-5M-9	43	215	8.5	0.017
215-5M-15	43	215	8.5	0.029
215-5M-25	43	215	8.5	0.048
225-5M-9	45	225	8.9	0.018
225-5M-15	45	225	8.9	0.030
225-5M-25	45	225	8.9	0.050
230-5M-9	46	230	9.1	0.019
230-5M-15	46	230	9.1	0.031
230-5M-25	46	230	9.1	0.051
235-5M-9	47	235	9.3	0.019
235-5M-15	47	235	9.3	0.032
235-5M-25	47	235	9.3	0.053
245-5M-9	49	245	9.6	0.020

Synchronous Belts

Synchro-Cog® HT

Synchronous Drive Belt

Synchro-Cog® HT Part Numbers

Part Number	Number Of Teeth	Pitch Length		Weight (lbs)
		(mm)	(in)	
5M Pitch – High Torque Synchronous (HTS) Sprockets: MPB, QD, Taper Bushed (5mm)				
245-5M-15	49	245	9.6	0.033
245-5M-25	49	245	9.6	0.055
250-5M-9	50	250	9.8	0.020
250-5M-15	50	250	9.8	0.034
250-5M-25	50	250	9.8	0.056
255-5M-9	51	255	10.0	0.021
255-5M-15	51	255	10.0	0.034
255-5M-25	51	255	10.0	0.057
260-5M-9	52	260	10.2	0.021
260-5M-15	52	260	10.2	0.035
260-5M-25	52	260	10.2	0.058
265-5M-9	53	265	10.4	0.021
265-5M-15	53	265	10.4	0.036
265-5M-25	53	265	10.4	0.059
270-5M-9	54	270	10.6	0.022
270-5M-15	54	270	10.6	0.036
270-5M-25	54	270	10.6	0.060
275-5M-9	55	275	10.8	0.022
275-5M-15	55	275	10.8	0.037
275-5M-25	55	275	10.8	0.061
280-5M-9	56	280	11.0	0.023
280-5M-15	56	280	11.0	0.038
280-5M-25	56	280	11.0	0.063
285-5M-9	57	285	11.2	0.023
285-5M-15	57	285	11.2	0.038
285-5M-25	57	285	11.2	0.064
290-5M-9	58	290	11.4	0.023
290-5M-15	58	290	11.4	0.039
290-5M-25	58	290	11.4	0.065
295-5M-9	59	295	11.6	0.024
295-5M-15	59	295	11.6	0.040
295-5M-25	59	295	11.6	0.066
300-5M-9	60	300	11.8	0.024

Part Number	Number Of Teeth	Pitch Length		Weight (lbs)
		(mm)	(in)	
5M Pitch – High Torque Synchronous (HTS) Sprockets: MPB, QD, Taper Bushed (5mm)				
300-5M-15	60	300	11.8	0.040
300-5M-25	60	300	11.8	0.067
305-5M-9	61	305	12.0	0.025
305-5M-15	61	305	12.0	0.041
305-5M-25	61	305	12.0	0.068
310-5M-9	62	310	12.2	0.025
310-5M-15	62	310	12.2	0.042
310-5M-25	62	310	12.2	0.069
320-5M-9	64	320	12.6	0.026
320-5M-15	64	320	12.6	0.043
320-5M-25	64	320	12.6	0.072
325-5M-9	65	325	12.8	0.026
325-5M-15	65	325	12.8	0.044
325-5M-25	65	325	12.8	0.073
330-5M-9	66	330	13.0	0.027
330-5M-15	66	330	13.0	0.044
330-5M-25	66	330	13.0	0.074
340-5M-9	68	340	13.4	0.027
340-5M-15	68	340	13.4	0.046
340-5M-25	68	340	13.4	0.076
345-5M-9	69	345	13.6	0.028
345-5M-15	69	345	13.6	0.046
345-5M-25	69	345	13.6	0.077
350-5M-9	70	350	13.8	0.028
350-5M-15	70	350	13.8	0.047
350-5M-25	70	350	13.8	0.078
360-5M-9	72	360	14.2	0.029
360-5M-15	72	360	14.2	0.048
360-5M-25	72	360	14.2	0.080
365-5M-9	73	365	14.4	0.029
365-5M-15	73	365	14.4	0.049
365-5M-25	73	365	14.4	0.082
370-5M-9	74	370	14.6	0.030

Synchro-Cog® HT

Synchronous Drive Belt

Part Number Example: **370-5M-15** = **370** - **5M** - **15**
Pitch Length (millimeters) Tooth Pitch (HTD profile) Width (millimeters)

Part Number	Number Of Teeth	Pitch Length		Weight (lbs)
		(mm)	(in)	
5M Pitch – High Torque Synchronous (HTS) Sprockets: MPB, QD, Taper Bushed (5mm)				
370-5M-15	74	370	14.6	0.050
370-5M-25	74	370	14.6	0.083
375-5M-9	75	375	14.8	0.030
375-5M-15	75	375	14.8	0.050
375-5M-25	75	375	14.8	0.084
380-5M-9	76	380	15.0	0.031
380-5M-15	76	380	15.0	0.051
380-5M-25	76	380	15.0	0.085
385-5M-9	77	385	15.2	0.031
385-5M-15	77	385	15.2	0.052
385-5M-25	77	385	15.2	0.086
390-5M-9	78	390	15.4	0.031
390-5M-15	78	390	15.4	0.052
390-5M-25	78	390	15.4	0.087
395-5M-9	79	395	15.6	0.032
395-5M-15	79	395	15.6	0.053
395-5M-25	79	395	15.6	0.088
400-5M-9	80	400	15.7	0.032
400-5M-15	80	400	15.7	0.054
400-5M-25	80	400	15.7	0.089
405-5M-9	81	405	15.9	0.033
405-5M-15	81	405	15.9	0.054
405-5M-25	81	405	15.9	0.090
410-5M-9	82	410	16.1	0.033
410-5M-15	82	410	16.1	0.055
410-5M-25	82	410	16.1	0.092
420-5M-9	84	420	16.5	0.034
420-5M-15	84	420	16.5	0.056
420-5M-25	84	420	16.5	0.094
425-5M-9	85	425	16.7	0.034
425-5M-15	85	425	16.7	0.057
425-5M-25	85	425	16.7	0.095
430-5M-9	86	430	16.9	0.035

Part Number	Number Of Teeth	Pitch Length		Weight (lbs)
		(mm)	(in)	
5M Pitch – High Torque Synchronous (HTS) Sprockets: MPB, QD, Taper Bushed (5mm)				
430-5M-15	86	430	16.9	0.058
430-5M-25	86	430	16.9	0.096
435-5M-9	87	435	17.1	0.035
435-5M-15	87	435	17.1	0.058
435-5M-25	87	435	17.1	0.097
440-5M-9	88	440	17.3	0.035
440-5M-15	88	440	17.3	0.059
440-5M-25	88	440	17.3	0.098
445-5M-9	89	445	17.5	0.036
445-5M-15	89	445	17.5	0.060
445-5M-25	89	445	17.5	0.099
450-5M-9	90	450	17.7	0.036
450-5M-15	90	450	17.7	0.060
450-5M-25	90	450	17.7	0.101
460-5M-9	92	460	18.1	0.037
460-5M-15	92	460	18.1	0.062
460-5M-25	92	460	18.1	0.103
465-5M-9	93	465	18.3	0.037
465-5M-15	93	465	18.3	0.062
465-5M-25	93	465	18.3	0.104
470-5M-9	94	470	18.5	0.038
470-5M-15	94	470	18.5	0.063
470-5M-25	94	470	18.5	0.105
475-5M-9	95	475	18.7	0.038
475-5M-15	95	475	18.7	0.064
475-5M-25	95	475	18.7	0.106
480-5M-9	96	480	18.9	0.039
480-5M-15	96	480	18.9	0.064
480-5M-25	96	480	18.9	0.107
490-5M-9	98	490	19.3	0.039
490-5M-15	98	490	19.3	0.066
490-5M-25	98	490	19.3	0.109
500-5M-9	100	500	19.7	0.040

Synchronous Belts

Synchro-Cog® HT

Synchronous Drive Belt

Synchro-Cog® HT Part Numbers

Part Number	Number Of Teeth	Pitch Length		Weight (lbs)
		(mm)	(in)	
5M Pitch – High Torque Synchronous (HTS) Sprockets: MPB, QD, Taper Bushed (5mm)				
500-5M-15	100	500	19.7	0.067
500-5M-25	100	500	19.7	0.112
505-5M-9	101	505	19.9	0.041
505-5M-15	101	505	19.9	0.068
505-5M-25	101	505	19.9	0.113
510-5M-9	102	510	20.1	0.041
510-5M-15	102	510	20.1	0.068
510-5M-25	102	510	20.1	0.114
520-5M-9	104	520	20.5	0.042
520-5M-15	104	520	20.5	0.070
520-5M-25	104	520	20.5	0.116
525-5M-9	105	525	20.7	0.042
525-5M-15	105	525	20.7	0.070
525-5M-25	105	525	20.7	0.117
530-5M-9	106	530	20.9	0.043
530-5M-15	106	530	20.9	0.071
530-5M-25	106	530	20.9	0.118
535-5M-9	107	535	21.1	0.043
535-5M-15	107	535	21.1	0.072
535-5M-25	107	535	21.1	0.120
540-5M-9	108	540	21.3	0.043
540-5M-15	108	540	21.3	0.072
540-5M-25	108	540	21.3	0.121
550-5M-9	110	550	21.7	0.044
550-5M-15	110	550	21.7	0.074
550-5M-25	110	550	21.7	0.123
560-5M-9	112	560	22.0	0.045
560-5M-15	112	560	22.0	0.075
560-5M-25	112	560	22.0	0.125
565-5M-9	113	565	22.2	0.045
565-5M-15	113	565	22.2	0.076
565-5M-25	113	565	22.2	0.126
570-5M-9	114	570	22.4	0.046

Part Number	Number Of Teeth	Pitch Length		Weight (lbs)
		(mm)	(in)	
5M Pitch – High Torque Synchronous (HTS) Sprockets: MPB, QD, Taper Bushed (5mm)				
570-5M-15	114	570	22.4	0.076
570-5M-25	114	570	22.4	0.127
575-5M-9	115	575	22.6	0.046
575-5M-15	115	575	22.6	0.077
575-5M-25	115	575	22.6	0.128
580-5M-9	116	580	22.8	0.047
580-5M-15	116	580	22.8	0.078
580-5M-25	116	580	22.8	0.130
585-5M-9	117	585	23.0	0.047
585-5M-15	117	585	23.0	0.078
585-5M-25	117	585	23.0	0.131
590-5M-9	118	590	23.2	0.047
590-5M-15	118	590	23.2	0.079
590-5M-25	118	590	23.2	0.132
600-5M-9	120	600	23.6	0.048
600-5M-15	120	600	23.6	0.080
600-5M-25	120	600	23.6	0.134
605-5M-9	121	605	23.8	0.049
605-5M-15	121	605	23.8	0.081
605-5M-25	121	605	23.8	0.135
610-5M-9	122	610	24.0	0.049
610-5M-15	122	610	24.0	0.082
610-5M-25	122	610	24.0	0.136
615-5M-9	123	615	24.2	0.049
615-5M-15	123	615	24.2	0.082
615-5M-25	123	615	24.2	0.137
620-5M-9	124	620	24.4	0.050
620-5M-15	124	620	24.4	0.083
620-5M-25	124	620	24.4	0.139
625-5M-9	125	625	24.6	0.050
625-5M-15	125	625	24.6	0.084
625-5M-25	125	625	24.6	0.140
635-5M-9	127	635	25.0	0.051

Synchro-Cog® HT

Synchronous Drive Belt

Part Number Example: **700-5M-15** = **700** - **5M** - **15**
Pitch Length (millimeters) Tooth Pitch (HTD profile) Width (millimeters)

Part Number	Number Of Teeth	Pitch Length		Weight (lbs)
		(mm)	(in)	
5M Pitch – High Torque Synchronous (HTS) Sprockets: MPB, QD, Taper Bushed (5mm)				
635-5M-15	127	635	25.0	0.085
635-5M-25	127	635	25.0	0.142
640-5M-9	128	640	25.2	0.051
640-5M-15	128	640	25.2	0.086
640-5M-25	128	640	25.2	0.143
645-5M-9	129	645	25.4	0.052
645-5M-15	129	645	25.4	0.086
645-5M-25	129	645	25.4	0.144
650-5M-9	130	650	25.6	0.052
650-5M-15	130	650	25.6	0.087
650-5M-25	130	650	25.6	0.145
655-5M-9	131	655	25.8	0.053
655-5M-15	131	655	25.8	0.088
655-5M-25	131	655	25.8	0.146
665-5M-9	133	665	26.2	0.053
665-5M-15	133	665	26.2	0.089
665-5M-25	133	665	26.2	0.149
670-5M-9	134	670	26.4	0.054
670-5M-15	134	670	26.4	0.090
670-5M-25	134	670	26.4	0.150
675-5M-9	135	675	26.6	0.054
675-5M-15	135	675	26.6	0.090
675-5M-25	135	675	26.6	0.151
685-5M-9	137	685	27.0	0.055
685-5M-15	137	685	27.0	0.092
685-5M-25	137	685	27.0	0.153
690-5M-9	138	690	27.2	0.056
690-5M-15	138	690	27.2	0.093
690-5M-25	138	690	27.2	0.154
695-5M-9	139	695	27.4	0.056
695-5M-15	139	695	27.4	0.093
695-5M-25	139	695	27.4	0.155
700-5M-9	140	700	27.6	0.056

Part Number	Number Of Teeth	Pitch Length		Weight (lbs)
		(mm)	(in)	
5M Pitch – High Torque Synchronous (HTS) Sprockets: MPB, QD, Taper Bushed (5mm)				
700-5M-15	140	700	27.6	0.094
700-5M-25	140	700	27.6	0.156
710-5M-9	142	710	28.0	0.057
710-5M-15	142	710	28.0	0.095
710-5M-25	142	710	28.0	0.159
720-5M-9	144	720	28.3	0.058
720-5M-15	144	720	28.3	0.097
720-5M-25	144	720	28.3	0.161
725-5M-9	145	725	28.5	0.058
725-5M-15	145	725	28.5	0.097
725-5M-25	145	725	28.5	0.162
740-5M-9	148	740	29.1	0.060
740-5M-15	148	740	29.1	0.099
740-5M-25	148	740	29.1	0.165
750-5M-9	150	750	29.5	0.060
750-5M-15	150	750	29.5	0.101
750-5M-25	150	750	29.5	0.168
755-5M-9	151	755	29.7	0.061
755-5M-15	151	755	29.7	0.101
755-5M-25	151	755	29.7	0.169
770-5M-9	154	770	30.3	0.062
770-5M-15	154	770	30.3	0.103
770-5M-25	154	770	30.3	0.172
775-5M-9	155	775	30.5	0.062
775-5M-15	155	775	30.5	0.104
775-5M-25	155	775	30.5	0.173
780-5M-9	156	780	30.7	0.063
780-5M-15	156	780	30.7	0.105
780-5M-25	156	780	30.7	0.174
790-5M-9	158	790	31.1	0.064
790-5M-15	158	790	31.1	0.106
790-5M-25	158	790	31.1	0.177
800-5M-9	160	800	31.5	0.064

Synchronous Belts

Synchro-Cog® HT

Synchronous Drive Belt

Synchro-Cog® HT Part Numbers

Part Number	Number Of Teeth	Pitch Length		Weight (lbs)
		(mm)	(in)	
5M Pitch – High Torque Synchronous (HTS) Sprockets: MPB, QD, Taper Bushed (5mm)				
800-5M-15	160	800	31.5	0.107
800-5M-25	160	800	31.5	0.179
825-5M-9	165	825	32.5	0.066
825-5M-15	165	825	32.5	0.111
825-5M-25	165	825	32.5	0.184
835-5M-9	167	835	32.9	0.067
835-5M-15	167	835	32.9	0.112
835-5M-25	167	835	32.9	0.187
850-5M-9	170	850	33.5	0.068
850-5M-15	170	850	33.5	0.114
850-5M-25	170	850	33.5	0.190
860-5M-9	172	860	33.9	0.069
860-5M-15	172	860	33.9	0.115
860-5M-25	172	860	33.9	0.192
870-5M-9	174	870	34.3	0.070
870-5M-15	174	870	34.3	0.117
870-5M-25	174	870	34.3	0.194
890-5M-9	178	890	35.0	0.072
890-5M-15	178	890	35.0	0.119
890-5M-25	178	890	35.0	0.199
900-5M-9	180	900	35.4	0.072
900-5M-15	180	900	35.4	0.121
900-5M-25	180	900	35.4	0.201
920-5M-9	184	920	36.2	0.074
920-5M-15	184	920	36.2	0.123
920-5M-25	184	920	36.2	0.206
925-5M-9	185	925	36.4	0.074
925-5M-15	185	925	36.4	0.124
925-5M-25	185	925	36.4	0.207
935-5M-9	187	935	36.8	0.075
935-5M-15	187	935	36.8	0.125
935-5M-25	187	935	36.8	0.209
940-5M-9	188	940	37.0	0.076

Part Number	Number Of Teeth	Pitch Length		Weight (lbs)
		(mm)	(in)	
5M Pitch – High Torque Synchronous (HTS) Sprockets: MPB, QD, Taper Bushed (5mm)				
940-5M-15	188	940	37.0	0.126
940-5M-25	188	940	37.0	0.210
950-5M-9	190	950	37.4	0.076
950-5M-15	190	950	37.4	0.127
950-5M-25	190	950	37.4	0.212
960-5M-9	192	960	37.8	0.077
960-5M-15	192	960	37.8	0.129
960-5M-25	192	960	37.8	0.215
965-5M-9	193	965	38.0	0.078
965-5M-15	193	965	38.0	0.129
965-5M-25	193	965	38.0	0.216
975-5M-9	195	975	38.4	0.078
975-5M-15	195	975	38.4	0.131
975-5M-25	195	975	38.4	0.218
980-5M-9	196	980	38.6	0.079
980-5M-15	196	980	38.6	0.131
980-5M-25	196	980	38.6	0.219
1000-5M-9	200	1000	39.4	0.080
1000-5M-15	200	1000	39.4	0.134
1000-5M-25	200	1000	39.4	0.223
1025-5M-9	205	1025	40.4	0.082
1025-5M-15	205	1025	40.4	0.137
1025-5M-25	205	1025	40.4	0.229
1050-5M-9	210	1050	41.3	0.084
1050-5M-15	210	1050	41.3	0.141
1050-5M-25	210	1050	41.3	0.235
1100-5M-9	220	1100	43.3	0.088
1100-5M-15	220	1100	43.3	0.147
1100-5M-25	220	1100	43.3	0.246
1115-5M-9	223	1115	43.9	0.090
1115-5M-15	223	1115	43.9	0.149
1115-5M-25	223	1115	43.9	0.249
1125-5M-9	225	1125	44.3	0.090

Synchro-Cog® HT

Synchronous Drive Belt

Part Number Example: **1300-5M-25** = **1300** - **5M** - **25**
Pitch Length (millimeters) Tooth Pitch (HTD profile) Width (millimeters)

Part Number	Number Of Teeth	Pitch Length		Weight (lbs)
		(mm)	(in)	
5M Pitch – High Torque Synchronous (HTS) Sprockets: MPB, OD, Taper Bushed (5mm)				
1125-5M-15	225	1125	44.3	0.151
1125-5M-25	225	1125	44.3	0.251
1145-5M-9	229	1145	45.1	0.092
1145-5M-15	229	1145	45.1	0.154
1145-5M-25	229	1145	45.1	0.256
1175-5M-9	235	1175	46.3	0.095
1175-5M-15	235	1175	46.3	0.158
1175-5M-25	235	1175	46.3	0.263
1180-5M-9	236	1180	46.5	0.095
1180-5M-15	236	1180	46.5	0.158
1180-5M-25	236	1180	46.5	0.264
1195-5M-9	239	1195	47.0	0.096
1195-5M-15	239	1195	47.0	0.160
1195-5M-25	239	1195	47.0	0.267
1200-5M-9	240	1200	47.2	0.097
1200-5M-15	240	1200	47.2	0.161
1200-5M-25	240	1200	47.2	0.268
1210-5M-9	242	1210	47.6	0.097
1210-5M-15	242	1210	47.6	0.162
1210-5M-25	242	1210	47.6	0.270
1250-5M-9	250	1250	49.2	0.101
1250-5M-15	250	1250	49.2	0.168
1250-5M-25	250	1250	49.2	0.279
1270-5M-9	254	1270	50.0	0.102
1270-5M-15	254	1270	50.0	0.170
1270-5M-25	254	1270	50.0	0.284
1290-5M-9	258	1290	50.8	0.104
1290-5M-15	258	1290	50.8	0.173
1290-5M-25	258	1290	50.8	0.288
1295-5M-9	259	1295	51.0	0.104
1295-5M-15	259	1295	51.0	0.174
1295-5M-25	259	1295	51.0	0.289
1300-5M-9	260	1300	51.2	0.105

Part Number	Number Of Teeth	Pitch Length		Weight (lbs)
		(mm)	(in)	
5M Pitch – High Torque Synchronous (HTS) Sprockets: MPB, OD, Taper Bushed (5mm)				
1300-5M-15	260	1300	51.2	0.174
1300-5M-25	260	1300	51.2	0.290
1340-5M-9	268	1340	52.8	0.108
1340-5M-15	268	1340	52.8	0.180
1340-5M-25	268	1340	52.8	0.299
1350-5M-9	270	1350	53.1	0.109
1350-5M-15	270	1350	53.1	0.181
1350-5M-25	270	1350	53.1	0.302
1375-5M-9	275	1375	54.1	0.111
1375-5M-15	275	1375	54.1	0.184
1375-5M-25	275	1375	54.1	0.307
1420-5M-9	284	1420	55.9	0.114
1420-5M-15	284	1420	55.9	0.190
1420-5M-25	284	1420	55.9	0.317
1450-5M-9	290	1450	57.1	0.117
1450-5M-15	290	1450	57.1	0.194
1450-5M-25	290	1450	57.1	0.324
1500-5M-9	300	1500	59.1	0.121
1500-5M-15	300	1500	59.1	0.201
1500-5M-25	300	1500	59.1	0.335
1595-5M-9	319	1595	62.8	0.128
1595-5M-15	319	1595	62.8	0.214
1595-5M-25	319	1595	62.8	0.356
1600-5M-9	320	1600	63.0	0.129
1600-5M-15	320	1600	63.0	0.215
1600-5M-25	320	1600	63.0	0.358
1685-5M-9	337	1685	66.3	0.136
1685-5M-15	337	1685	66.3	0.226
1685-5M-25	337	1685	66.3	0.377
1690-5M-9	338	1690	66.5	0.136
1690-5M-15	338	1690	66.5	0.227
1690-5M-25	338	1690	66.5	0.378
1790-5M-9	358	1790	70.5	0.144

Synchronous Belts

Synchro-Cog® HT

Synchronous Drive Belt

Synchro-Cog® HT Part Numbers

Part Number	Number Of Teeth	Pitch Length		Weight (lbs)
		(mm)	(in)	
5M Pitch – High Torque Synchronous (HTS) Sprockets: MPB, QD, Taper Bushed (5mm)				
1790-5M-15	358	1790	70.5	0.240
1790-5M-25	358	1790	70.5	0.400
1800-5M-9	360	1800	70.9	0.145
1800-5M-15	360	1800	70.9	0.241
1800-5M-25	360	1800	70.9	0.402
1895-5M-9	379	1895	74.6	0.152
1895-5M-15	379	1895	74.6	0.254
1895-5M-25	379	1895	74.6	0.423
2000-5M-9	400	2000	78.7	0.161
2000-5M-15	400	2000	78.7	0.268
2000-5M-25	400	2000	78.7	0.447
2100-5M-9	420	2100	82.7	0.169
2100-5M-15	420	2100	82.7	0.282
2100-5M-25	420	2100	82.7	0.469
2350-5M-9	470	2350	92.5	0.189
2350-5M-15	470	2350	92.5	0.315
2350-5M-25	470	2350	92.5	0.525
2525-5M-9	505	2525	99.4	0.203
2525-5M-15	505	2525	99.4	0.339
2525-5M-25	505	2525	99.4	0.564
2635-5M-9	527	2635	103.7	0.212
2635-5M-15	527	2635	103.7	0.353
2635-5M-25	527	2635	103.7	0.589
4260-5M-9	852	4260	167.7	0.343
4260-5M-15	852	4260	167.7	0.571
4260-5M-25	852	4260	167.7	0.952
8M Pitch – High Torque Synchronous (HTS) Sprockets: MPB, QD, Taper Bushed (8mm)				
320-8M-20	40	320	12.6	0.077
320-8M-30	40	320	12.6	0.116
320-8M-50	40	320	12.6	0.193
320-8M-85	40	320	12.6	0.328
368-8M-20	46	368	14.5	0.089

Part Number	Number Of Teeth	Pitch Length		Weight (lbs)
		(mm)	(in)	
8M Pitch – High Torque Synchronous (HTS) Sprockets: MPB, QD, Taper Bushed (8mm)				
368-8M-30	46	368	14.5	0.133
368-8M-50	46	368	14.5	0.222
368-8M-85	46	368	14.5	0.378
400-8M-20	50	400	15.7	0.097
400-8M-30	50	400	15.7	0.145
400-8M-50	50	400	15.7	0.242
400-8M-85	50	400	15.7	0.411
408-8M-20	51	408	16.1	0.099
408-8M-30	51	408	16.1	0.148
408-8M-50	51	408	16.1	0.246
408-8M-85	51	408	16.1	0.419
424-8M-20	53	424	16.7	0.102
424-8M-30	53	424	16.7	0.154
424-8M-50	53	424	16.7	0.256
424-8M-85	53	424	16.7	0.435
440-8M-20	55	440	17.3	0.106
440-8M-30	55	440	17.3	0.159
440-8M-50	55	440	17.3	0.266
440-8M-85	55	440	17.3	0.452
448-8M-20	56	448	17.6	0.108
448-8M-30	56	448	17.6	0.162
448-8M-50	56	448	17.6	0.271
448-8M-85	56	448	17.6	0.460
480-8M-20	60	480	18.9	0.116
480-8M-30	60	480	18.9	0.174
480-8M-50	60	480	18.9	0.290
480-8M-85	60	480	18.9	0.493
512-8M-20	64	512	20.2	0.124
512-8M-30	64	512	20.2	0.186
512-8M-50	64	512	20.2	0.309
512-8M-85	64	512	20.2	0.526
520-8M-20	65	520	20.5	0.126
520-8M-30	65	520	20.5	0.188

Synchro-Cog® HT

Synchronous Drive Belt

Part Number Example: **600-8M-85** = **600** - **8M** - **85**
Pitch Length (millimeters) Tooth Pitch (HTD profile) Width (millimeters)

Part Number	Number Of Teeth	Pitch Length		Weight (lbs)
		(mm)	(in)	
8M Pitch – High Torque Synchronous (HTS) Sprockets: MPB, QD, Taper Bushed (8mm)				
520-8M-50	65	520	20.5	0.314
520-8M-85	65	520	20.5	0.534
536-8M-20	67	536	21.1	0.129
536-8M-30	67	536	21.1	0.194
536-8M-50	67	536	21.1	0.324
536-8M-85	67	536	21.1	0.550
544-8M-20	68	544	21.4	0.131
544-8M-30	68	544	21.4	0.197
544-8M-50	68	544	21.4	0.328
544-8M-85	68	544	21.4	0.558
560-8M-20	70	560	22.0	0.135
560-8M-30	70	560	22.0	0.203
560-8M-50	70	560	22.0	0.338
560-8M-85	70	560	22.0	0.575
568-8M-20	71	568	22.4	0.137
568-8M-30	71	568	22.4	0.206
568-8M-50	71	568	22.4	0.343
568-8M-85	71	568	22.4	0.583
576-8M-20	72	576	22.7	0.139
576-8M-30	72	576	22.7	0.209
576-8M-50	72	576	22.7	0.348
576-8M-85	72	576	22.7	0.591
584-8M-20	73	584	23.0	0.141
584-8M-30	73	584	23.0	0.212
584-8M-50	73	584	23.0	0.353
584-8M-85	73	584	23.0	0.599
592-8M-20	74	592	23.3	0.143
592-8M-30	74	592	23.3	0.214
592-8M-50	74	592	23.3	0.357
592-8M-85	74	592	23.3	0.608
600-8M-20	75	600	23.6	0.145
600-8M-30	75	600	23.6	0.217
600-8M-50	75	600	23.6	0.362

Part Number	Number Of Teeth	Pitch Length		Weight (lbs)
		(mm)	(in)	
8M Pitch – High Torque Synchronous (HTS) Sprockets: MPB, QD, Taper Bushed (8mm)				
600-8M-85	75	600	23.6	0.616
608-8M-20	76	608	23.9	0.147
608-8M-30	76	608	23.9	0.220
608-8M-50	76	608	23.9	0.367
608-8M-85	76	608	23.9	0.624
624-8M-20	78	624	24.6	0.151
624-8M-30	78	624	24.6	0.226
624-8M-50	78	624	24.6	0.377
624-8M-85	78	624	24.6	0.641
632-8M-20	79	632	24.9	0.153
632-8M-30	79	632	24.9	0.229
632-8M-50	79	632	24.9	0.382
632-8M-85	79	632	24.9	0.649
640-8M-20	80	640	25.2	0.155
640-8M-30	80	640	25.2	0.232
640-8M-50	80	640	25.2	0.386
640-8M-85	80	640	25.2	0.657
648-8M-20	81	648	25.5	0.157
648-8M-30	81	648	25.5	0.235
648-8M-50	81	648	25.5	0.391
648-8M-85	81	648	25.5	0.665
656-8M-20	82	656	25.8	0.158
656-8M-30	82	656	25.8	0.238
656-8M-50	82	656	25.8	0.396
656-8M-85	82	656	25.8	0.673
680-8M-20	85	680	26.8	0.164
680-8M-30	85	680	26.8	0.246
680-8M-50	85	680	26.8	0.411
680-8M-85	85	680	26.8	0.698
688-8M-20	86	688	27.1	0.166
688-8M-30	86	688	27.1	0.249
688-8M-50	86	688	27.1	0.415
688-8M-85	86	688	27.1	0.706

Synchronous Belts

Synchro-Cog® HT

Synchronous Drive Belt

Synchro-Cog® HT Part Numbers

Part Number	Number Of Teeth	Pitch Length		Weight (lbs)
		(mm)	(in)	
8M Pitch – High Torque Synchronous (HTS) Sprockets: MPB, QD, Taper Bushed (8mm)				
696-8M-20	87	696	27.4	0.168
696-8M-30	87	696	27.4	0.252
696-8M-50	87	696	27.4	0.420
696-8M-85	87	696	27.4	0.714
712-8M-20	89	712	28.0	0.172
712-8M-30	89	712	28.0	0.258
712-8M-50	89	712	28.0	0.430
712-8M-85	89	712	28.0	0.731
720-8M-20	90	720	28.3	0.174
720-8M-30	90	720	28.3	0.261
720-8M-50	90	720	28.3	0.435
720-8M-85	90	720	28.3	0.739
760-8M-20	95	760	29.9	0.184
760-8M-30	95	760	29.9	0.275
760-8M-50	95	760	29.9	0.459
760-8M-85	95	760	29.9	0.780
768-8M-20	96	768	30.2	0.186
768-8M-30	96	768	30.2	0.278
768-8M-50	96	768	30.2	0.464
768-8M-85	96	768	30.2	0.788
776-8M-20	97	776	30.6	0.187
776-8M-30	97	776	30.6	0.281
776-8M-50	97	776	30.6	0.469
776-8M-85	97	776	30.6	0.797
784-8M-20	98	784	30.9	0.189
784-8M-30	98	784	30.9	0.284
784-8M-50	98	784	30.9	0.473
784-8M-85	98	784	30.9	0.805
792-8M-20	99	792	31.2	0.191
792-8M-30	99	792	31.2	0.287
792-8M-50	99	792	31.2	0.478
792-8M-85	99	792	31.2	0.813
800-8M-20	100	800	31.5	0.193

Part Number	Number Of Teeth	Pitch Length		Weight (lbs)
		(mm)	(in)	
8M Pitch – High Torque Synchronous (HTS) Sprockets: MPB, QD, Taper Bushed (8mm)				
800-8M-30	100	800	31.5	0.290
800-8M-50	100	800	31.5	0.483
800-8M-85	100	800	31.5	0.821
816-8M-20	102	816	32.1	0.197
816-8M-30	102	816	32.1	0.296
816-8M-50	102	816	32.1	0.493
816-8M-85	102	816	32.1	0.838
824-8M-20	103	824	32.4	0.199
824-8M-30	103	824	32.4	0.299
824-8M-50	103	824	32.4	0.498
824-8M-85	103	824	32.4	0.846
840-8M-20	105	840	33.1	0.203
840-8M-30	105	840	33.1	0.304
840-8M-50	105	840	33.1	0.507
840-8M-85	105	840	33.1	0.862
848-8M-20	106	848	33.4	0.205
848-8M-30	106	848	33.4	0.307
848-8M-50	106	848	33.4	0.512
848-8M-85	106	848	33.4	0.870
856-8M-20	107	856	33.7	0.207
856-8M-30	107	856	33.7	0.310
856-8M-50	107	856	33.7	0.517
856-8M-85	107	856	33.7	0.879
864-8M-20	108	864	34.0	0.209
864-8M-30	108	864	34.0	0.313
864-8M-50	108	864	34.0	0.522
864-8M-85	108	864	34.0	0.887
880-8M-20	110	880	34.6	0.213
880-8M-30	110	880	34.6	0.319
880-8M-50	110	880	34.6	0.531
880-8M-85	110	880	34.6	0.903
896-8M-20	112	896	35.3	0.216
896-8M-30	112	896	35.3	0.325

Synchro-Cog® HT

Synchronous Drive Belt

Part Number Example: **1000-8M-50** = **1000** - **8M** - **50**
Pitch Length (millimeters) Tooth Pitch (HTD profile) Width (millimeters)

Part Number	Number Of Teeth	Pitch Length		Weight (lbs)
		(mm)	(in)	
8M Pitch – High Torque Synchronous (HTS) Sprockets: MPB, OD, Taper Bushed (8mm)				
896-8M-50	112	896	35.3	0.541
896-8M-85	112	896	35.3	0.920
912-8M-20	114	912	35.9	0.220
912-8M-30	114	912	35.9	0.330
912-8M-50	114	912	35.9	0.551
912-8M-85	114	912	35.9	0.936
920-8M-20	115	920	36.2	0.222
920-8M-30	115	920	36.2	0.333
920-8M-50	115	920	36.2	0.556
920-8M-85	115	920	36.2	0.944
928-8M-20	116	928	36.5	0.224
928-8M-30	116	928	36.5	0.336
928-8M-50	116	928	36.5	0.560
928-8M-85	116	928	36.5	0.953
936-8M-20	117	936	36.9	0.226
936-8M-30	117	936	36.9	0.339
936-8M-50	117	936	36.9	0.565
936-8M-85	117	936	36.9	0.961
944-8M-20	118	944	37.2	0.228
944-8M-30	118	944	37.2	0.342
944-8M-50	118	944	37.2	0.570
944-8M-85	118	944	37.2	0.969
952-8M-20	119	952	37.5	0.230
952-8M-30	119	952	37.5	0.345
952-8M-50	119	952	37.5	0.575
952-8M-85	119	952	37.5	0.977
960-8M-20	120	960	37.8	0.232
960-8M-30	120	960	37.8	0.348
960-8M-50	120	960	37.8	0.580
960-8M-85	120	960	37.8	0.985
968-8M-20	121	968	38.1	0.234
968-8M-30	121	968	38.1	0.351
968-8M-50	121	968	38.1	0.585

Part Number	Number Of Teeth	Pitch Length		Weight (lbs)
		(mm)	(in)	
8M Pitch – High Torque Synchronous (HTS) Sprockets: MPB, OD, Taper Bushed (8mm)				
968-8M-85	121	968	38.1	0.994
976-8M-20	122	976	38.4	0.236
976-8M-30	122	976	38.4	0.354
976-8M-50	122	976	38.4	0.589
976-8M-85	122	976	38.4	1.002
1000-8M-20	125	1000	39.4	0.242
1000-8M-30	125	1000	39.4	0.362
1000-8M-50	125	1000	39.4	0.604
1000-8M-85	125	1000	39.4	1.027
1016-8M-20	127	1016	40.0	0.245
1016-8M-30	127	1016	40.0	0.368
1016-8M-50	127	1016	40.0	0.614
1016-8M-85	127	1016	40.0	1.043
1024-8M-20	128	1024	40.3	0.247
1024-8M-30	128	1024	40.3	0.371
1024-8M-50	128	1024	40.3	0.618
1024-8M-85	128	1024	40.3	1.051
1040-8M-20	130	1040	40.9	0.251
1040-8M-30	130	1040	40.9	0.377
1040-8M-50	130	1040	40.9	0.628
1040-8M-85	130	1040	40.9	1.068
1056-8M-20	132	1056	41.6	0.255
1056-8M-30	132	1056	41.6	0.383
1056-8M-50	132	1056	41.6	0.638
1056-8M-85	132	1056	41.6	1.084
1064-8M-20	133	1064	41.9	0.257
1064-8M-30	133	1064	41.9	0.385
1064-8M-50	133	1064	41.9	0.642
1064-8M-85	133	1064	41.9	1.092
1080-8M-20	135	1080	42.5	0.261
1080-8M-30	135	1080	42.5	0.391
1080-8M-50	135	1080	42.5	0.652
1080-8M-85	135	1080	42.5	1.109

Synchronous Belts

Synchro-Cog® HT

Synchronous Drive Belt

Synchro-Cog® HT Part Numbers

Part Number	Number Of Teeth	Pitch Length		Weight (lbs)
		(mm)	(in)	
8M Pitch – High Torque Synchronous (HTS) Sprockets: MPB, OD, Taper Bushed (8mm)				
1104-8M-20	138	1104	43.5	0.267
1104-8M-30	138	1104	43.5	0.400
1104-8M-50	138	1104	43.5	0.667
1104-8M-85	138	1104	43.5	1.133
1120-8M-20	140	1120	44.1	0.271
1120-8M-30	140	1120	44.1	0.406
1120-8M-50	140	1120	44.1	0.676
1120-8M-85	140	1120	44.1	1.150
1128-8M-20	141	1128	44.4	0.272
1128-8M-30	141	1128	44.4	0.409
1128-8M-50	141	1128	44.4	0.681
1128-8M-85	141	1128	44.4	1.158
1136-8M-20	142	1136	44.7	0.274
1136-8M-30	142	1136	44.7	0.412
1136-8M-50	142	1136	44.7	0.686
1136-8M-85	142	1136	44.7	1.166
1152-8M-20	144	1152	45.4	0.278
1152-8M-30	144	1152	45.4	0.417
1152-8M-50	144	1152	45.4	0.696
1152-8M-85	144	1152	45.4	1.183
1160-8M-20	145	1160	45.7	0.280
1160-8M-30	145	1160	45.7	0.420
1160-8M-50	145	1160	45.7	0.700
1160-8M-85	145	1160	45.7	1.191
1168-8M-20	146	1168	46.0	0.282
1168-8M-30	146	1168	46.0	0.423
1168-8M-50	146	1168	46.0	0.705
1168-8M-85	146	1168	46.0	1.199
1184-8M-20	148	1184	46.6	0.286
1184-8M-30	148	1184	46.6	0.429
1184-8M-50	148	1184	46.6	0.715
1184-8M-85	148	1184	46.6	1.215
1200-8M-20	150	1200	47.2	0.290

Part Number	Number Of Teeth	Pitch Length		Weight (lbs)
		(mm)	(in)	
8M Pitch – High Torque Synchronous (HTS) Sprockets: MPB, OD, Taper Bushed (8mm)				
1200-8M-30	150	1200	47.2	0.435
1200-8M-50	150	1200	47.2	0.725
1200-8M-85	150	1200	47.2	1.232
1208-8M-20	151	1208	47.6	0.292
1208-8M-30	151	1208	47.6	0.438
1208-8M-50	151	1208	47.6	0.729
1208-8M-85	151	1208	47.6	1.240
1216-8M-20	152	1216	47.9	0.294
1216-8M-30	152	1216	47.9	0.441
1216-8M-50	152	1216	47.9	0.734
1216-8M-85	152	1216	47.9	1.248
1224-8M-20	153	1224	48.2	0.296
1224-8M-30	153	1224	48.2	0.443
1224-8M-50	153	1224	48.2	0.739
1224-8M-85	153	1224	48.2	1.256
1240-8M-20	155	1240	48.8	0.300
1240-8M-30	155	1240	48.8	0.449
1240-8M-50	155	1240	48.8	0.749
1240-8M-85	155	1240	48.8	1.273
1248-8M-20	156	1248	49.1	0.301
1248-8M-30	156	1248	49.1	0.452
1248-8M-50	156	1248	49.1	0.754
1248-8M-85	156	1248	49.1	1.281
1256-8M-20	157	1256	49.4	0.303
1256-8M-30	157	1256	49.4	0.455
1256-8M-50	157	1256	49.4	0.758
1256-8M-85	157	1256	49.4	1.289
1264-8M-20	158	1264	49.8	0.305
1264-8M-30	158	1264	49.8	0.458
1264-8M-50	158	1264	49.8	0.763
1264-8M-85	158	1264	49.8	1.298
1272-8M-20	159	1272	50.1	0.307
1272-8M-30	159	1272	50.1	0.461

Synchro-Cog® HT

Synchronous Drive Belt

Part Number Example: **1400-8M-50** = **1400** - **8M** - **50**
Pitch Length (millimeters) Tooth Pitch (HTD profile) Width (millimeters)

Part Number	Number Of Teeth	Pitch Length		Weight (lbs)
		(mm)	(in)	
8M Pitch – High Torque Synchronous (HTS) Sprockets: MPB, QD, Taper Bushed (8mm)				
1272-8M-50	159	1272	50.1	0.768
1272-8M-85	159	1272	50.1	1.306
1280-8M-20	160	1280	50.4	0.309
1280-8M-30	160	1280	50.4	0.464
1280-8M-50	160	1280	50.4	0.773
1280-8M-85	160	1280	50.4	1.314
1304-8M-20	163	1304	51.3	0.315
1304-8M-30	163	1304	51.3	0.472
1304-8M-50	163	1304	51.3	0.787
1304-8M-85	163	1304	51.3	1.339
1312-8M-20	164	1312	51.7	0.317
1312-8M-30	164	1312	51.7	0.475
1312-8M-50	164	1312	51.7	0.792
1312-8M-85	164	1312	51.7	1.347
1320-8M-20	165	1320	52.0	0.319
1320-8M-30	165	1320	52.0	0.478
1320-8M-50	165	1320	52.0	0.797
1320-8M-85	165	1320	52.0	1.355
1328-8M-20	166	1328	52.3	0.321
1328-8M-30	166	1328	52.3	0.481
1328-8M-50	166	1328	52.3	0.802
1328-8M-85	166	1328	52.3	1.363
1344-8M-20	168	1344	52.9	0.325
1344-8M-30	168	1344	52.9	0.487
1344-8M-50	168	1344	52.9	0.812
1344-8M-85	168	1344	52.9	1.380
1352-8M-20	169	1352	53.2	0.327
1352-8M-30	169	1352	53.2	0.490
1352-8M-50	169	1352	53.2	0.816
1352-8M-85	169	1352	53.2	1.388
1360-8M-20	170	1360	53.5	0.328
1360-8M-30	170	1360	53.5	0.493
1360-8M-50	170	1360	53.5	0.821

Part Number	Number Of Teeth	Pitch Length		Weight (lbs)
		(mm)	(in)	
8M Pitch – High Torque Synchronous (HTS) Sprockets: MPB, QD, Taper Bushed (8mm)				
1360-8M-85	170	1360	53.5	1.396
1376-8M-20	172	1376	54.2	0.332
1376-8M-30	172	1376	54.2	0.499
1376-8M-50	172	1376	54.2	0.831
1376-8M-85	172	1376	54.2	1.413
1392-8M-20	174	1392	54.8	0.336
1392-8M-30	174	1392	54.8	0.504
1392-8M-50	174	1392	54.8	0.841
1392-8M-85	174	1392	54.8	1.429
1400-8M-20	175	1400	55.1	0.338
1400-8M-30	175	1400	55.1	0.507
1400-8M-50	175	1400	55.1	0.845
1400-8M-85	175	1400	55.1	1.437
1424-8M-20	178	1424	56.1	0.344
1424-8M-30	178	1424	56.1	0.516
1424-8M-50	178	1424	56.1	0.860
1424-8M-85	178	1424	56.1	1.462
1440-8M-20	180	1440	56.7	0.348
1440-8M-30	180	1440	56.7	0.522
1440-8M-50	180	1440	56.7	0.870
1440-8M-85	180	1440	56.7	1.478
1456-8M-20	182	1456	57.3	0.352
1456-8M-30	182	1456	57.3	0.528
1456-8M-50	182	1456	57.3	0.879
1456-8M-85	182	1456	57.3	1.495
1464-8M-20	183	1464	57.6	0.354
1464-8M-30	183	1464	57.6	0.530
1464-8M-50	183	1464	57.6	0.884
1464-8M-85	183	1464	57.6	1.503
1480-8M-20	185	1480	58.3	0.357
1480-8M-30	185	1480	58.3	0.536
1480-8M-50	185	1480	58.3	0.894
1480-8M-85	185	1480	58.3	1.519

Synchronous Belts

Synchro-Cog® HT

Synchronous Drive Belt

Synchro-Cog® HT Part Numbers

Part Number	Number Of Teeth	Pitch Length		Weight (lbs)
		(mm)	(in)	
8M Pitch – High Torque Synchronous (HTS) Sprockets: MPB, OD, Taper Bushed (8mm)				
1512-8M-20	189	1512	59.5	0.365
1512-8M-30	189	1512	59.5	0.548
1512-8M-50	189	1512	59.5	0.913
1512-8M-85	189	1512	59.5	1.552
1520-8M-20	190	1520	59.8	0.367
1520-8M-30	190	1520	59.8	0.551
1520-8M-50	190	1520	59.8	0.918
1520-8M-85	190	1520	59.8	1.560
1552-8M-20	194	1552	61.1	0.375
1552-8M-30	194	1552	61.1	0.562
1552-8M-50	194	1552	61.1	0.937
1552-8M-85	194	1552	61.1	1.593
1560-8M-20	195	1560	61.4	0.377
1560-8M-30	195	1560	61.4	0.565
1560-8M-50	195	1560	61.4	0.942
1560-8M-85	195	1560	61.4	1.601
1576-8M-20	197	1576	62.0	0.381
1576-8M-30	197	1576	62.0	0.571
1576-8M-50	197	1576	62.0	0.952
1576-8M-85	197	1576	62.0	1.618
1584-8M-20	198	1584	62.4	0.383
1584-8M-30	198	1584	62.4	0.574
1584-8M-50	198	1584	62.4	0.956
1584-8M-85	198	1584	62.4	1.626
1600-8M-20	200	1600	63.0	0.386
1600-8M-30	200	1600	63.0	0.580
1600-8M-50	200	1600	63.0	0.966
1600-8M-85	200	1600	63.0	1.642
1640-8M-20	205	1640	64.6	0.396
1640-8M-30	205	1640	64.6	0.594
1640-8M-50	205	1640	64.6	0.990
1640-8M-85	205	1640	64.6	1.684
1648-8M-20	206	1648	64.9	0.398

Part Number	Number Of Teeth	Pitch Length		Weight (lbs)
		(mm)	(in)	
8M Pitch – High Torque Synchronous (HTS) Sprockets: MPB, OD, Taper Bushed (8mm)				
1648-8M-30	206	1648	64.9	0.597
1648-8M-50	206	1648	64.9	0.995
1648-8M-85	206	1648	64.9	1.692
1680-8M-20	210	1680	66.1	0.406
1680-8M-30	210	1680	66.1	0.609
1680-8M-50	210	1680	66.1	1.014
1680-8M-85	210	1680	66.1	1.725
1696-8M-20	212	1696	66.8	0.410
1696-8M-30	212	1696	66.8	0.614
1696-8M-50	212	1696	66.8	1.024
1696-8M-85	212	1696	66.8	1.741
1728-8M-20	216	1728	68.0	0.417
1728-8M-30	216	1728	68.0	0.626
1728-8M-50	216	1728	68.0	1.043
1728-8M-85	216	1728	68.0	1.774
1744-8M-20	218	1744	68.7	0.421
1744-8M-30	218	1744	68.7	0.632
1744-8M-50	218	1744	68.7	1.053
1744-8M-85	218	1744	68.7	1.790
1752-8M-20	219	1752	69.0	0.423
1752-8M-30	219	1752	69.0	0.635
1752-8M-50	219	1752	69.0	1.058
1752-8M-85	219	1752	69.0	1.798
1760-8M-20	220	1760	69.3	0.425
1760-8M-30	220	1760	69.3	0.638
1760-8M-50	220	1760	69.3	1.063
1760-8M-85	220	1760	69.3	1.807
1784-8M-20	223	1784	70.2	0.431
1784-8M-30	223	1784	70.2	0.646
1784-8M-50	223	1784	70.2	1.077
1784-8M-85	223	1784	70.2	1.831
1792-8M-20	224	1792	70.6	0.433
1792-8M-30	224	1792	70.6	0.649

Synchro-Cog® HT

Synchronous Drive Belt

Part Number Example: **2000-8M-50** = **2000** - **8M** - **50**
Pitch Length (millimeters) Tooth Pitch (HTD profile) Width (millimeters)

Part Number	Number Of Teeth	Pitch Length		Weight (lbs)
		(mm)	(in)	
8M Pitch – High Torque Synchronous (HTS) Sprockets: MPB, QD, Taper Bushed (8mm)				
1792-8M-50	224	1792	70.6	1.082
1792-8M-85	224	1792	70.6	1.840
1800-8M-20	225	1800	70.9	0.435
1800-8M-30	225	1800	70.9	0.652
1800-8M-50	225	1800	70.9	1.087
1800-8M-85	225	1800	70.9	1.848
1840-8M-20	230	1840	72.4	0.444
1840-8M-30	230	1840	72.4	0.667
1840-8M-50	230	1840	72.4	1.111
1840-8M-85	230	1840	72.4	1.889
1856-8M-20	232	1856	73.1	0.448
1856-8M-30	232	1856	73.1	0.672
1856-8M-50	232	1856	73.1	1.121
1856-8M-85	232	1856	73.1	1.905
1896-8M-20	237	1896	74.6	0.458
1896-8M-30	237	1896	74.6	0.687
1896-8M-50	237	1896	74.6	1.145
1896-8M-85	237	1896	74.6	1.946
1904-8M-20	238	1904	75.0	0.460
1904-8M-30	238	1904	75.0	0.690
1904-8M-50	238	1904	75.0	1.150
1904-8M-85	238	1904	75.0	1.955
1920-8M-20	240	1920	75.6	0.464
1920-8M-30	240	1920	75.6	0.696
1920-8M-50	240	1920	75.6	1.159
1920-8M-85	240	1920	75.6	1.971
1928-8M-20	241	1928	75.9	0.466
1928-8M-30	241	1928	75.9	0.699
1928-8M-50	241	1928	75.9	1.164
1928-8M-85	241	1928	75.9	1.979
1936-8M-20	242	1936	76.2	0.468
1936-8M-30	242	1936	76.2	0.701
1936-8M-50	242	1936	76.2	1.169

Part Number	Number Of Teeth	Pitch Length		Weight (lbs)
		(mm)	(in)	
8M Pitch – High Torque Synchronous (HTS) Sprockets: MPB, QD, Taper Bushed (8mm)				
1936-8M-85	242	1936	76.2	1.987
1952-8M-20	244	1952	76.9	0.471
1952-8M-30	244	1952	76.9	0.707
1952-8M-50	244	1952	76.9	1.179
1952-8M-85	244	1952	76.9	2.004
1992-8M-20	249	1992	78.4	0.481
1992-8M-30	249	1992	78.4	0.722
1992-8M-50	249	1992	78.4	1.203
1992-8M-85	249	1992	78.4	2.045
2000-8M-20	250	2000	78.7	0.483
2000-8M-30	250	2000	78.7	0.725
2000-8M-50	250	2000	78.7	1.208
2000-8M-85	250	2000	78.7	2.053
2056-8M-20	257	2056	80.9	0.497
2056-8M-30	257	2056	80.9	0.745
2056-8M-50	257	2056	80.9	1.241
2056-8M-85	257	2056	80.9	2.111
2080-8M-20	260	2080	81.9	0.502
2080-8M-30	260	2080	81.9	0.754
2080-8M-50	260	2080	81.9	1.256
2080-8M-85	260	2080	81.9	2.135
2104-8M-20	263	2104	82.8	0.508
2104-8M-30	263	2104	82.8	0.762
2104-8M-50	263	2104	82.8	1.270
2104-8M-85	263	2104	82.8	2.160
2136-8M-20	267	2136	84.1	0.516
2136-8M-30	267	2136	84.1	0.774
2136-8M-50	267	2136	84.1	1.290
2136-8M-85	267	2136	84.1	2.193
2160-8M-20	270	2160	85.0	0.522
2160-8M-30	270	2160	85.0	0.783
2160-8M-50	270	2160	85.0	1.304
2160-8M-85	270	2160	85.0	2.217

Synchronous Belts

Synchro-Cog® HT

Synchronous Drive Belt

Synchro-Cog® HT

Part Numbers

Part Number	Number Of Teeth	Pitch Length		Weight (lbs)
		(mm)	(in)	
8M Pitch – High Torque Synchronous (HTS) Sprockets: MPB, OD, Taper Bushed (8mm)				
2208-8M-20	276	2208	86.9	0.533
2208-8M-30	276	2208	86.9	0.800
2208-8M-50	276	2208	86.9	1.333
2208-8M-85	276	2208	86.9	2.267
2240-8M-20	280	2240	88.2	0.541
2240-8M-30	280	2240	88.2	0.812
2240-8M-50	280	2240	88.2	1.353
2240-8M-85	280	2240	88.2	2.299
2272-8M-20	284	2272	89.4	0.549
2272-8M-30	284	2272	89.4	0.823
2272-8M-50	284	2272	89.4	1.372
2272-8M-85	284	2272	89.4	2.332
2304-8M-20	288	2304	90.7	0.557
2304-8M-30	288	2304	90.7	0.835
2304-8M-50	288	2304	90.7	1.391
2304-8M-85	288	2304	90.7	2.365
2328-8M-20	291	2328	91.7	0.562
2328-8M-30	291	2328	91.7	0.843
2328-8M-50	291	2328	91.7	1.406
2328-8M-85	291	2328	91.7	2.390
2392-8M-20	299	2392	94.2	0.578
2392-8M-30	299	2392	94.2	0.867
2392-8M-50	299	2392	94.2	1.444
2392-8M-85	299	2392	94.2	2.455
2400-8M-20	300	2400	94.5	0.580
2400-8M-30	300	2400	94.5	0.870
2400-8M-50	300	2400	94.5	1.449
2400-8M-85	300	2400	94.5	2.464
2504-8M-20	313	2504	98.6	0.605
2504-8M-30	313	2504	98.6	0.907
2504-8M-50	313	2504	98.6	1.512
2504-8M-85	313	2504	98.6	2.570
2584-8M-20	323	2584	101.7	0.624

Part Number	Number Of Teeth	Pitch Length		Weight (lbs)
		(mm)	(in)	
8M Pitch – High Torque Synchronous (HTS) Sprockets: MPB, OD, Taper Bushed (8mm)				
2584-8M-30	323	2584	101.7	0.936
2584-8M-50	323	2584	101.7	1.560
2584-8M-85	323	2584	101.7	2.653
2600-8M-20	325	2600	102.4	0.628
2600-8M-30	325	2600	102.4	0.942
2600-8M-50	325	2600	102.4	1.570
2600-8M-85	325	2600	102.4	2.669
2656-8M-20	332	2656	104.6	0.642
2656-8M-30	332	2656	104.6	0.962
2656-8M-50	332	2656	104.6	1.604
2656-8M-85	332	2656	104.6	2.726
2736-8M-20	342	2736	107.7	0.661
2736-8M-30	342	2736	107.7	0.991
2736-8M-50	342	2736	107.7	1.652
2736-8M-85	342	2736	107.7	2.809
2800-8M-20	350	2800	110.2	0.676
2800-8M-30	350	2800	110.2	1.014
2800-8M-50	350	2800	110.2	1.691
2800-8M-85	350	2800	110.2	2.874
3048-8M-20	381	3048	120.0	0.736
3048-8M-30	381	3048	120.0	1.104
3048-8M-50	381	3048	120.0	1.841
3048-8M-85	381	3048	120.0	3.129
3120-8M-20	390	3120	122.8	0.754
3120-8M-30	390	3120	122.8	1.130
3120-8M-50	390	3120	122.8	1.884
3120-8M-85	390	3120	122.8	3.203
3168-8M-20	396	3168	124.7	0.765
3168-8M-30	396	3168	124.7	1.148
3168-8M-50	396	3168	124.7	1.913
3168-8M-85	396	3168	124.7	3.252
3200-8M-20	400	3200	126.0	0.773
3200-8M-30	400	3200	126.0	1.159

Synchro-Cog® HT

Synchronous Drive Belt

Part Number Example: **3200-8M-50** = **3200** - **8M** - **50**
Pitch Length (millimeters) Tooth Pitch (HTD profile) Width (millimeters)

Part Number	Number Of Teeth	Pitch Length		Weight (lbs)
		(mm)	(in)	
8M Pitch – High Torque Synchronous (HTS) Sprockets: MPB, QD, Taper Bushed (8mm)				
3200-8M-50	400	3200	126.0	1.932
3200-8M-85	400	3200	126.0	3.285
3280-8M-20	410	3280	129.1	0.792
3280-8M-30	410	3280	129.1	1.188
3280-8M-50	410	3280	129.1	1.981
3280-8M-85	410	3280	129.1	3.367
3400-8M-20	425	3400	133.9	0.821
3400-8M-30	425	3400	133.9	1.232
3400-8M-50	425	3400	133.9	2.053
3400-8M-85	425	3400	133.9	3.490
3600-8M-20	450	3600	141.7	0.870
3600-8M-30	450	3600	141.7	1.304
3600-8M-50	450	3600	141.7	2.174
3600-8M-85	450	3600	141.7	3.696
3824-8M-20	478	3824	150.6	0.924
3824-8M-30	478	3824	150.6	1.385
3824-8M-50	478	3824	150.6	2.309
3824-8M-85	478	3824	150.6	3.925
4000-8M-20	500	4000	157.5	0.966
4000-8M-30	500	4000	157.5	1.449
4000-8M-50	500	4000	157.5	2.415
4000-8M-85	500	4000	157.5	4.106
4400-8M-20	550	4400	173.2	1.063
4400-8M-30	550	4400	173.2	1.594
4400-8M-50	550	4400	173.2	2.657
4400-8M-85	550	4400	173.2	4.517
5120-8M-20	640	5120	201.6	1.237
5120-8M-30	640	5120	201.6	1.855
5120-8M-50	640	5120	201.6	3.092
5120-8M-85	640	5120	201.6	5.256
5576-8M-20	697	5576	219.5	1.347
5576-8M-30	697	5576	219.5	2.020
5576-8M-50	697	5576	219.5	3.367

Part Number	Number Of Teeth	Pitch Length		Weight (lbs)
		(mm)	(in)	
8M Pitch – High Torque Synchronous (HTS) Sprockets: MPB, QD, Taper Bushed (8mm)				
5576-8M-85	697	5576	219.5	5.724
5600-8M-20	700	5600	220.5	1.353
5600-8M-30	700	5600	220.5	2.029
5600-8M-50	700	5600	220.5	3.382
5600-8M-85	700	5600	220.5	5.749
5960-8M-20	745	5960	234.6	1.440
5960-8M-30	745	5960	234.6	2.159
5960-8M-50	745	5960	234.6	3.599
5960-8M-85	745	5960	234.6	6.118
14M Pitch – High Torque Synchronous (HTS) Sprockets: MPB, QD, Taper Bushed (14mm)				
966-14M-40	69	966	38.0	0.757
966-14M-55	69	966	38.0	1.040
966-14M-85	69	966	38.0	1.608
966-14M-115	69	966	38.0	2.175
966-14M-170	69	966	38.0	3.216
1036-14M-40	74	1036	40.8	0.812
1036-14M-55	74	1036	40.8	1.116
1036-14M-85	74	1036	40.8	1.724
1036-14M-115	74	1036	40.8	2.333
1036-14M-170	74	1036	40.8	3.449
1092-14M-40	78	1092	43.0	0.855
1092-14M-55	78	1092	43.0	1.176
1092-14M-85	78	1092	43.0	1.818
1092-14M-115	78	1092	43.0	2.459
1092-14M-170	78	1092	43.0	3.635
1120-14M-40	80	1120	44.1	0.877
1120-14M-55	80	1120	44.1	1.206
1120-14M-85	80	1120	44.1	1.864
1120-14M-115	80	1120	44.1	2.522
1120-14M-170	80	1120	44.1	3.729
1148-14M-40	82	1148	45.2	0.899
1148-14M-55	82	1148	45.2	1.236

Synchronous Belts

Synchro-Cog® HT

Synchronous Drive Belt

Synchro-Cog® HT

Part Numbers

Part Number	Number Of Teeth	Pitch Length		Weight (lbs)
		(mm)	(in)	
14M Pitch – High Torque Synchronous (HTS) Sprockets: MPB, OD, Taper Bushed (14mm)				
1148-14M-85	82	1148	45.2	1.911
1148-14M-115	82	1148	45.2	2.585
1148-14M-170	82	1148	45.2	3.822
1190-14M-40	85	1190	46.9	0.932
1190-14M-55	85	1190	46.9	1.282
1190-14M-85	85	1190	46.9	1.981
1190-14M-115	85	1190	46.9	2.680
1190-14M-170	85	1190	46.9	3.962
1246-14M-40	89	1246	49.1	0.976
1246-14M-55	89	1246	49.1	1.342
1246-14M-85	89	1246	49.1	2.074
1246-14M-115	89	1246	49.1	2.806
1246-14M-170	89	1246	49.1	4.148
1260-14M-40	90	1260	49.6	0.987
1260-14M-55	90	1260	49.6	1.357
1260-14M-85	90	1260	49.6	2.097
1260-14M-115	90	1260	49.6	2.838
1260-14M-170	90	1260	49.6	4.195
1316-14M-40	94	1316	51.8	1.031
1316-14M-55	94	1316	51.8	1.417
1316-14M-85	94	1316	51.8	2.191
1316-14M-115	94	1316	51.8	2.964
1316-14M-170	94	1316	51.8	4.381
1344-14M-40	96	1344	52.9	1.053
1344-14M-55	96	1344	52.9	1.448
1344-14M-85	96	1344	52.9	2.237
1344-14M-115	96	1344	52.9	3.027
1344-14M-170	96	1344	52.9	4.474
1400-14M-40	100	1400	55.1	1.097
1400-14M-55	100	1400	55.1	1.508
1400-14M-85	100	1400	55.1	2.330
1400-14M-115	100	1400	55.1	3.153
1400-14M-170	100	1400	55.1	4.661

Part Number	Number Of Teeth	Pitch Length		Weight (lbs)
		(mm)	(in)	
14M Pitch – High Torque Synchronous (HTS) Sprockets: MPB, OD, Taper Bushed (14mm)				
1442-14M-40	103	1442	56.8	1.130
1442-14M-55	103	1442	56.8	1.553
1442-14M-85	103	1442	56.8	2.400
1442-14M-115	103	1442	56.8	3.247
1442-14M-170	103	1442	56.8	4.800
1456-14M-40	104	1456	57.3	1.140
1456-14M-55	104	1456	57.3	1.568
1456-14M-85	104	1456	57.3	2.424
1456-14M-115	104	1456	57.3	3.279
1456-14M-170	104	1456	57.3	4.847
1470-14M-40	105	1470	57.9	1.151
1470-14M-55	105	1470	57.9	1.583
1470-14M-85	105	1470	57.9	2.447
1470-14M-115	105	1470	57.9	3.310
1470-14M-170	105	1470	57.9	4.894
1540-14M-40	110	1540	60.6	1.206
1540-14M-55	110	1540	60.6	1.659
1540-14M-85	110	1540	60.6	2.563
1540-14M-115	110	1540	60.6	3.468
1540-14M-170	110	1540	60.6	5.127
1568-14M-40	112	1568	61.7	1.228
1568-14M-55	112	1568	61.7	1.689
1568-14M-85	112	1568	61.7	2.610
1568-14M-115	112	1568	61.7	3.531
1568-14M-170	112	1568	61.7	5.220
1610-14M-40	115	1610	63.4	1.261
1610-14M-55	115	1610	63.4	1.734
1610-14M-85	115	1610	63.4	2.680
1610-14M-115	115	1610	63.4	3.626
1610-14M-170	115	1610	63.4	5.360
1652-14M-40	118	1652	65.0	1.294
1652-14M-55	118	1652	65.0	1.779
1652-14M-85	118	1652	65.0	2.750

Synchro-Cog® HT

Synchronous Drive Belt

Part Number Example: **2100-14M-40** = **2100** - **14M** - **40**
Pitch Length (millimeters) Tooth Pitch (HTD profile) Width (millimeters)

Part Number	Number Of Teeth	Pitch Length		Weight (lbs)
		(mm)	(in)	
14M Pitch – High Torque Synchronous (HTS) Sprockets: MPB, QD, Taper Bushed (14mm)				
1652-14M-115	118	1652	65.0	3.720
1652-14M-170	118	1652	65.0	5.500
1750-14M-40	125	1750	68.9	1.371
1750-14M-55	125	1750	68.9	1.885
1750-14M-85	125	1750	68.9	2.913
1750-14M-115	125	1750	68.9	3.941
1750-14M-170	125	1750	68.9	5.826
1764-14M-40	126	1764	69.4	1.382
1764-14M-55	126	1764	69.4	1.900
1764-14M-85	126	1764	69.4	2.936
1764-14M-115	126	1764	69.4	3.973
1764-14M-170	126	1764	69.4	5.872
1778-14M-40	127	1778	70.0	1.393
1778-14M-55	127	1778	70.0	1.915
1778-14M-85	127	1778	70.0	2.960
1778-14M-115	127	1778	70.0	4.004
1778-14M-170	127	1778	70.0	5.919
1792-14M-40	128	1792	70.6	1.404
1792-14M-55	128	1792	70.6	1.930
1792-14M-85	128	1792	70.6	2.983
1792-14M-115	128	1792	70.6	4.036
1792-14M-170	128	1792	70.6	5.966
1806-14M-40	129	1806	71.1	1.415
1806-14M-55	129	1806	71.1	1.945
1806-14M-85	129	1806	71.1	3.006
1806-14M-115	129	1806	71.1	4.067
1806-14M-170	129	1806	71.1	6.012
1820-14M-40	130	1820	71.7	1.426
1820-14M-55	130	1820	71.7	1.960
1820-14M-85	130	1820	71.7	3.029
1820-14M-115	130	1820	71.7	4.099
1820-14M-170	130	1820	71.7	6.059
1890-14M-40	135	1890	74.4	1.480

Part Number	Number Of Teeth	Pitch Length		Weight (lbs)
		(mm)	(in)	
14M Pitch – High Torque Synchronous (HTS) Sprockets: MPB, QD, Taper Bushed (14mm)				
1890-14M-55	135	1890	74.4	2.036
1890-14M-85	135	1890	74.4	3.146
1890-14M-115	135	1890	74.4	4.256
1890-14M-170	135	1890	74.4	6.292
1932-14M-40	138	1932	76.1	1.513
1932-14M-55	138	1932	76.1	2.081
1932-14M-85	138	1932	76.1	3.216
1932-14M-115	138	1932	76.1	4.351
1932-14M-170	138	1932	76.1	6.432
1960-14M-40	140	1960	77.2	1.535
1960-14M-55	140	1960	77.2	2.111
1960-14M-85	140	1960	77.2	3.262
1960-14M-115	140	1960	77.2	4.414
1960-14M-170	140	1960	77.2	6.525
2100-14M-40	150	2100	82.7	1.645
2100-14M-55	150	2100	82.7	2.262
2100-14M-85	150	2100	82.7	3.495
2100-14M-115	150	2100	82.7	4.729
2100-14M-170	150	2100	82.7	6.991
2240-14M-40	160	2240	88.2	1.755
2240-14M-55	160	2240	88.2	2.413
2240-14M-85	160	2240	88.2	3.729
2240-14M-115	160	2240	88.2	5.044
2240-14M-170	160	2240	88.2	7.457
2310-14M-40	165	2310	90.9	1.809
2310-14M-55	165	2310	90.9	2.488
2310-14M-85	165	2310	90.9	3.845
2310-14M-115	165	2310	90.9	5.202
2310-14M-170	165	2310	90.9	7.690
2450-14M-40	175	2450	96.5	1.919
2450-14M-55	175	2450	96.5	2.639
2450-14M-85	175	2450	96.5	4.078
2450-14M-115	175	2450	96.5	5.517

Synchronous Belts

Synchro-Cog® HT

Synchronous Drive Belt

Synchro-Cog® HT Part Numbers

Part Number	Number Of Teeth	Pitch Length		Weight (lbs)
		(mm)	(in)	
14M Pitch – High Torque Synchronous (HTS) Sprockets: MPB, OD, Taper Bushed (14mm)				
2450-14M-170	175	2450	96.5	8.156
2590-14M-40	185	2590	102.0	2.029
2590-14M-55	185	2590	102.0	2.790
2590-14M-85	185	2590	102.0	4.311
2590-14M-115	185	2590	102.0	5.833
2590-14M-170	185	2590	102.0	8.622
2660-14M-40	190	2660	104.7	2.084
2660-14M-55	190	2660	104.7	2.865
2660-14M-85	190	2660	104.7	4.428
2660-14M-115	190	2660	104.7	5.990
2660-14M-170	190	2660	104.7	8.855
2800-14M-40	200	2800	110.2	2.193
2800-14M-55	200	2800	110.2	3.016
2800-14M-85	200	2800	110.2	4.661
2800-14M-115	200	2800	110.2	6.306
2800-14M-170	200	2800	110.2	9.321
3108-14M-40	222	3108	122.4	2.435
3108-14M-55	222	3108	122.4	3.347
3108-14M-85	222	3108	122.4	5.173
3108-14M-115	222	3108	122.4	6.999
3108-14M-170	222	3108	122.4	10.347
3150-14M-40	225	3150	124.0	2.467
3150-14M-55	225	3150	124.0	3.393
3150-14M-85	225	3150	124.0	5.243
3150-14M-115	225	3150	124.0	7.094
3150-14M-170	225	3150	124.0	10.486
3304-14M-40	236	3304	130.1	2.588
3304-14M-55	236	3304	130.1	3.559
3304-14M-85	236	3304	130.1	5.500
3304-14M-115	236	3304	130.1	7.441
3304-14M-170	236	3304	130.1	10.999
3360-14M-40	240	3360	132.3	2.632
3360-14M-55	240	3360	132.3	3.619

Part Number	Number Of Teeth	Pitch Length		Weight (lbs)
		(mm)	(in)	
14M Pitch – High Torque Synchronous (HTS) Sprockets: MPB, OD, Taper Bushed (14mm)				
3360-14M-85	240	3360	132.3	5.593
3360-14M-115	240	3360	132.3	7.567
3360-14M-170	240	3360	132.3	11.186
3500-14M-40	250	3500	137.8	2.742
3500-14M-55	250	3500	137.8	3.770
3500-14M-85	250	3500	137.8	5.826
3500-14M-115	250	3500	137.8	7.882
3500-14M-170	250	3500	137.8	11.652
3668-14M-40	262	3668	144.4	2.873
3668-14M-55	262	3668	144.4	3.951
3668-14M-85	262	3668	144.4	6.105
3668-14M-115	262	3668	144.4	8.260
3668-14M-170	262	3668	144.4	12.211
3850-14M-40	275	3850	151.6	3.016
3850-14M-55	275	3850	151.6	4.147
3850-14M-85	275	3850	151.6	6.408
3850-14M-115	275	3850	151.6	8.670
3850-14M-170	275	3850	151.6	12.817
4326-14M-40	309	4326	170.3	3.389
4326-14M-55	309	4326	170.3	4.659
4326-14M-85	309	4326	170.3	7.201
4326-14M-115	309	4326	170.3	9.742
4326-14M-170	309	4326	170.3	14.401
4536-14M-40	324	4536	178.6	3.553
4536-14M-55	324	4536	178.6	4.885
4536-14M-85	324	4536	178.6	7.550
4536-14M-115	324	4536	178.6	10.215
4536-14M-170	324	4536	178.6	15.101
4578-14M-40	327	4578	180.2	3.586
4578-14M-55	327	4578	180.2	4.931
4578-14M-85	327	4578	180.2	7.620
4578-14M-115	327	4578	180.2	10.310
4578-14M-170	327	4578	180.2	15.240

Synchro-Cog® HT

Synchronous Drive Belt

Part Number Example: **3500-14M-55** = **3500** - **14M** - **55**
Pitch Length (millimeters) Tooth Pitch (HTD profile) Width (millimeters)

Part Number	Number Of Teeth	Pitch Length		Weight (lbs)
		(mm)	(in)	
14M Pitch – High Torque Synchronous (HTS) Sprockets: MPB, QD, Taper Bushed (14mm)				
4956-14M-40	354	4956	195.1	3.882
4956-14M-55	354	4956	195.1	5.338
4956-14M-85	354	4956	195.1	8.249
4956-14M-115	354	4956	195.1	11.161
4956-14M-170	354	4956	195.1	16.499
5320-14M-40	380	5320	209.4	4.167
5320-14M-55	380	5320	209.4	5.730
5320-14M-85	380	5320	209.4	8.855
5320-14M-115	380	5320	209.4	11.981
5320-14M-170	380	5320	209.4	17.710
5740-14M-40	410	5740	226.0	4.496
5740-14M-55	410	5740	226.0	6.182
5740-14M-85	410	5740	226.0	9.554
5740-14M-115	410	5740	226.0	12.926
5740-14M-170	410	5740	226.0	19.109
6160-14M-40	440	6160	242.5	4.825
6160-14M-55	440	6160	242.5	6.635
6160-14M-85	440	6160	242.5	10.253
6160-14M-115	440	6160	242.5	13.872
6160-14M-170	440	6160	242.5	20.507
6860-14M-40	490	6860	270.1	5.373
6860-14M-55	490	6860	270.1	7.389
6860-14M-85	490	6860	270.1	11.419
6860-14M-115	490	6860	270.1	15.449
6860-14M-170	490	6860	270.1	22.837

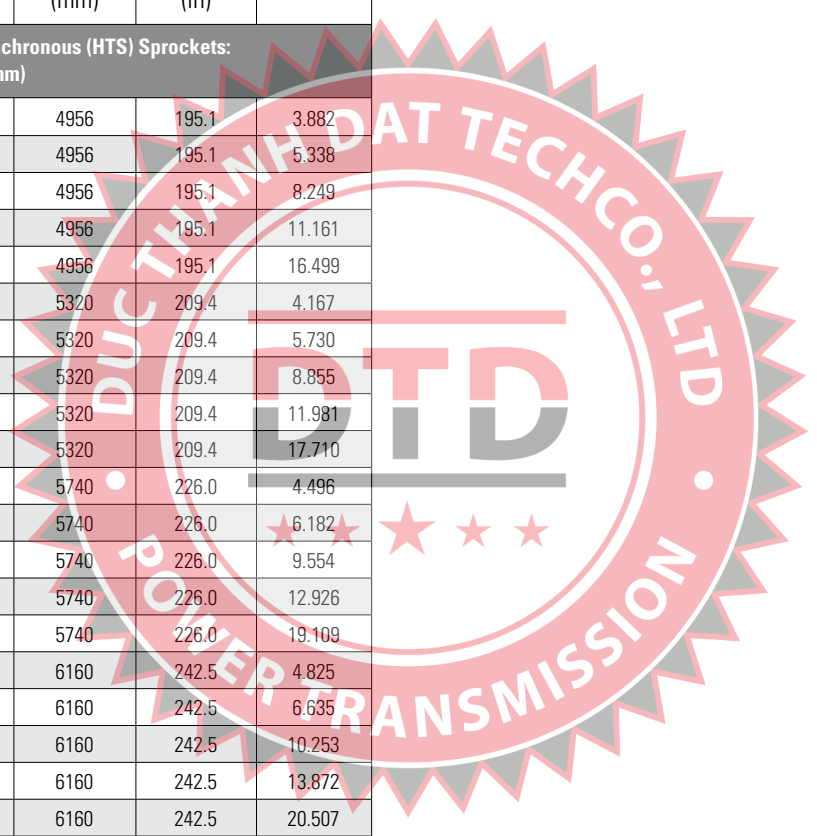

Synchronous Belts

Synchro-Cog® HT Sleeves

- Full factory width sleeves
- All sleeves will have the edges trimmed before shipment
- Cut sleeves cannot be accepted for return
- All weights are approximate

Timken maintains inventory of most Carlisle® sleeve sizes. Non-stock sizes will be indicated by an asterisk following the part number. Contact customer service for availability. Minimum order quantity and/or extended lead times may apply.

Occasional production inconsistencies which may render a portion of the sleeve unusable can be present as a normal part of the production process.

Each sleeve is inspected to ensure that it contains 90% or more usable product. A full width sleeve with less than 10% unusable product is considered acceptable.



Synchro-Cog® HT Sleeve Part Numbers

Part Number	Sleeve Width (mm)	Sleeve Weight (lbs)
3M Pitch – High Torque Synchronous (HTS) Sprockets: MPB, QD, Taper Bushed (3mm)		
144-3M-100SL	100	0.078
150-3M-160SL	160	0.130
159-3M-200SL	200	0.172
168-3M-200SL	200	0.182
177-3M-200SL	200	0.192
180-3M-200SL	200	0.195
186-3M-160SL	160	0.161
189-3M-160SL	160	0.164
192-3M-160SL	160	0.166
201-3M-200SL	200	0.218
207-3M-200SL	200	0.224
210-3M-200SL	200	0.227
213-3M-200SL	200	0.231
222-3M-200SL	200	0.240
225-3M-200SL	200	0.244
228-3M-200SL	200	0.247
234-3M-200SL	200	0.253
240-3M-200SL	200	0.260
252-3M-450SL	450	0.614
255-3M-450SL	450	0.621
264-3M-450SL	450	0.643
267-3M-450SL	450	0.650
276-3M-450SL	450	0.672
285-3M-450SL	450	0.694
300-3M-450SL	450	0.731
312-3M-450SL	450	0.760
318-3M-450SL	450	0.775
324-3M-450SL	450	0.789
330-3M-450SL	450	0.804
339-3M-450SL	450	0.826
357-3M-450SL	450	0.870
360-3M-450SL	450	0.877
363-3M-450SL	450	0.884

Synchro-Cog® HT Sleeves

Part Number Example: **375-3M-450SL** = **375** - **3M** - **450** **SL**
Pitch Length (millimeters) Tooth Pitch (HTD profile) Width (millimeters) Sleeve

Part Number	Sleeve Width (mm)	Sleeve Weight (lbs)
3M Pitch – High Torque Synchronous (HTS) Sprockets: MPB, QD, Taper Bushed (3mm)		
375-3M-450SL	450	0.913
384-3M-450SL	450	0.935
390-3M-450SL	450	0.950
405-3M-450SL	450	0.987
420-3M-450SL	450	1.023
447-3M-450SL	450	1.089
456-3M-450SL	450	1.111
474-3M-450SL	450	1.155
483-3M-450SL	450	1.177
495-3M-450SL	450	1.206
501-3M-450SL	450	1.220
513-3M-450SL	450	1.250
522-3M-450SL	450	1.272
531-3M-450SL	450	1.293
564-3M-200SL	200	0.611
570-3M-450SL	450	1.388
582-3M-200SL	200	0.630
600-3M-450SL	450	1.462
633-3M-450SL	450	1.542
711-3M-450SL	450	1.732
735-3M-450SL	450	1.790
750-3M-450SL	450	1.827
804-3M-450SL	450	1.959
1026-3M-450SL	450	2.499
1401-3M-200SL	200	1.517
5M Pitch – High Torque Synchronous (HTS) Sprockets: MPB, QD, Taper Bushed (5mm)		
180-5M-200SL	200	0.322
200-5M-200SL	200	0.358
210-5M-200SL	200	0.375
215-5M-200SL	200	0.384
225-5M-200SL	200	0.402
230-5M-450SL	450	0.925

Part Number	Sleeve Width (mm)	Sleeve Weight (lbs)
5M Pitch – High Torque Synchronous (HTS) Sprockets: MPB, QD, Taper Bushed (5mm)		
235-5M-200SL	200	0.420
245-5M-450SL	450	0.985
250-5M-450SL	450	1.005
255-5M-200SL	200	0.456
260-5M-450SL	450	1.046
265-5M-450SL	450	1.066
270-5M-450SL	450	1.086
275-5M-450SL	450	1.106
280-5M-450SL	450	1.126
285-5M-450SL	450	1.146
290-5M-450SL	450	1.166
295-5M-450SL	450	1.186
300-5M-450SL	450	1.207
305-5M-450SL	450	1.227
310-5M-450SL	450	1.247
320-5M-450SL	450	1.287
325-5M-450SL	450	1.307
330-5M-450SL	450	1.327
340-5M-450SL	450	1.367
345-5M-450SL	450	1.388
350-5M-450SL	450	1.408
360-5M-450SL	450	1.448
365-5M-450SL	450	1.468
370-5M-450SL	450	1.488
375-5M-450SL	450	1.508
380-5M-450SL	450	1.528
385-5M-450SL	450	1.548
390-5M-450SL	450	1.569
395-5M-450SL	450	1.589
400-5M-450SL	450	1.609
405-5M-450SL	450	1.629
410-5M-450SL	450	1.649
420-5M-450SL	450	1.689

Synchronous Belts

Synchro-Cog® HT

Sleeves

Synchro-Cog® HT Sleeve Part Numbers

Part Number	Sleeve Width (mm)	Sleeve Weight (lbs)
5M Pitch – High Torque Synchronous (HTS) Sprockets: MPB, OD, Taper Bushed (5mm)		
425-5M-450SL	450	1.709
430-5M-450SL	450	1.729
435-5M-450SL	450	1.750
440-5M-450SL	450	1.770
445-5M-450SL	450	1.790
450-5M-450SL	450	1.810
460-5M-450SL	450	1.850
465-5M-450SL	450	1.870
470-5M-450SL	450	1.890
475-5M-450SL	450	1.910
480-5M-450SL	450	1.931
490-5M-450SL	450	1.971
500-5M-450SL	450	2.011
505-5M-450SL	450	2.031
510-5M-450SL	450	2.051
520-5M-450SL	450	2.091
525-5M-450SL	450	2.112
530-5M-450SL	450	2.132
535-5M-450SL	450	2.152
540-5M-450SL	450	2.172
550-5M-450SL	450	2.212
560-5M-450SL	450	2.252
565-5M-200SL	200	1.010
570-5M-450SL	450	2.293
575-5M-450SL	450	2.313
580-5M-450SL	450	2.333
585-5M-450SL	450	2.353
590-5M-450SL	450	2.373
600-5M-450SL	450	2.413
605-5M-450SL	450	2.433
610-5M-450SL	450	2.453
615-5M-450SL	450	2.474
620-5M-450SL	450	2.494

Part Number	Sleeve Width (mm)	Sleeve Weight (lbs)
5M Pitch – High Torque Synchronous (HTS) Sprockets: MPB, OD, Taper Bushed (5mm)		
625-5M-450SL	450	2.514
635-5M-450SL	450	2.554
640-5M-450SL	450	2.574
645-5M-450SL	450	2.594
650-5M-450SL	450	2.614
655-5M-450SL	450	2.634
665-5M-450SL	450	2.675
670-5M-450SL	450	2.695
675-5M-450SL	450	2.715
685-5M-450SL	450	2.755
690-5M-450SL	450	2.775
695-5M-450SL	450	2.795
700-5M-450SL	450	2.815
710-5M-450SL	450	2.856
720-5M-450SL	450	2.896
725-5M-450SL	450	2.916
740-5M-450SL	450	2.976
750-5M-450SL	450	3.016
755-5M-450SL	450	3.000
770-5M-450SL	450	3.097
775-5M-450SL	450	3.117
780-5M-450SL	450	3.137
790-5M-450SL	450	3.177
800-5M-450SL	450	3.218
825-5M-450SL	450	3.318
835-5M-450SL	450	3.358
850-5M-450SL	450	3.419
860-5M-450SL	450	3.459
870-5M-450SL	450	3.499
890-5M-450SL	450	3.580
900-5M-450SL	450	3.620
920-5M-450SL	450	3.700
925-5M-450SL	450	3.720

Synchro-Cog® HT Sleeves

Part Number Example: **1000-5M-450SL** = **1000** - **5M** - **450** **SL**
Pitch Length (millimeters) Tooth Pitch (HTD profile) Width (millimeters) Sleeve

Part Number	Sleeve Width (mm)	Sleeve Weight (lbs)
5M Pitch – High Torque Synchronous (HTS) Sprockets: MPB, OD, Taper Bushed (5mm)		
935-5M-450SL	450	3.761
940-5M-450SL	450	3.781
950-5M-450SL	450	3.821
960-5M-450SL	450	3.861
965-5M-450SL	450	3.881
975-5M-450SL	450	3.921
980-5M-450SL	450	3.942
1000-5M-450SL	450	4.022
1025-5M-450SL	450	4.123
1050-5M-450SL	450	4.223
1100-5M-450SL	450	4.424
1115-5M-450SL	450	4.485
1125-5M-450SL	450	4.525
1145-5M-450SL	450	4.605
1175-5M-450SL	450	4.726
1180-5M-450SL	450	4.746
1195-5M-450SL	450	4.806
1200-5M-450SL	450	4.826
1210-5M-450SL	450	4.867
1250-5M-450SL	450	5.027
1270-5M-450SL	450	5.108
1290-5M-450SL	450	5.188
1295-5M-450SL	450	5.208
1300-5M-450SL	450	5.229
1340-5M-450SL	450	5.389
1350-5M-450SL	450	5.430
1375-5M-450SL	450	5.530
1420-5M-450SL	450	5.711
1450-5M-450SL	450	5.832
1500-5M-450SL	450	6.033
1595-5M-450SL	450	6.415
1600-5M-450SL	450	6.435
1685-5M-450SL	450	6.777

Part Number	Sleeve Width (mm)	Sleeve Weight (lbs)
5M Pitch – High Torque Synchronous (HTS) Sprockets: MPB, OD, Taper Bushed (5mm)		
1690-5M-450SL	450	6.797
1790-5M-450SL	450	7.199
1800-5M-450SL	450	7.240
1895-5M-440SL	440	7.452
2000-5M-450SL	450	8.044
2100-5M-450SL	450	8.446
2350-5M-450SL	450	9.452
2525-5M-450SL	450	10.156
2635-5M-450SL	450	10.598
4260-5M-440SL	440	16.753
8M Pitch – High Torque Synchronous (HTS) Sprockets: MPB, OD, Taper Bushed (8mm)		
320-8M-450SL	450	1.739
368-8M-450SL	450	2.000
400-8M-450SL	450	2.174
408-8M-450SL	450	2.217
424-8M-450SL	450	2.304
440-8M-450SL	450	2.391
448-8M-450SL	450	2.435
480-8M-450SL	450	2.609
512-8M-450SL	450	2.783
520-8M-450SL	450	2.826
536-8M-450SL	450	2.913
544-8M-450SL	450	2.956
560-8M-450SL	450	3.043
568-8M-450SL	450	3.087
576-8M-450SL	450	3.130
584-8M-450SL	450	3.174
592-8M-450SL	450	3.217
600-8M-450SL	450	3.261
608-8M-450SL	450	3.304
624-8M-450SL	450	3.391
632-8M-450SL	450	3.435

Synchronous Belts

Synchro-Cog® HT

Sleeves

Synchro-Cog® HT Sleeve Part Numbers

Part Number	Sleeve Width (mm)	Sleeve Weight (lbs)
8M Pitch – High Torque Synchronous (HTS) Sprockets: MPB, QD, Taper Bushed (8mm)		
640-8M-450SL	450	3.478
648-8M-450SL	450	3.522
656-8M-450SL	450	3.565
680-8M-450SL	450	3.696
688-8M-450SL	450	3.739
696-8M-450SL	450	3.782
712-8M-450SL	450	3.869
720-8M-450SL	450	3.913
760-8M-450SL	450	4.130
768-8M-450SL	450	4.174
776-8M-450SL	450	4.217
784-8M-450SL	450	4.261
792-8M-450SL	450	4.304
800-8M-450SL	450	4.348
816-8M-450SL	450	4.435
824-8M-450SL	450	4.478
840-8M-450SL	450	4.565
848-8M-450SL	450	4.609
856-8M-450SL	450	4.652
864-8M-450SL	450	4.695
880-8M-450SL	450	4.782
896-8M-450SL	450	4.869
912-8M-450SL	450	4.956
920-8M-450SL	450	5.000
928-8M-450SL	450	5.043
936-8M-450SL	450	5.087
944-8M-450SL	450	5.130
952-8M-450SL	450	5.174
960-8M-450SL	450	5.217
968-8M-450SL	450	5.261
976-8M-450SL	450	5.304
1000-8M-450SL	450	5.435
1016-8M-450SL	450	5.522

Part Number	Sleeve Width (mm)	Sleeve Weight (lbs)
8M Pitch – High Torque Synchronous (HTS) Sprockets: MPB, QD, Taper Bushed (8mm)		
1024-8M-450SL	450	5.565
1040-8M-450SL	450	5.652
1056-8M-450SL	450	5.739
1064-8M-450SL	450	5.782
1080-8M-450SL	450	5.869
1104-8M-450SL	450	6.000
1120-8M-450SL	450	6.087
1128-8M-450SL	450	6.130
1136-8M-450SL	450	6.174
1152-8M-450SL	450	6.261
1160-8M-450SL	450	6.304
1168-8M-450SL	450	6.348
1184-8M-450SL	450	6.435
1200-8M-450SL	450	6.521
1208-8M-450SL	450	6.565
1216-8M-450SL	450	6.608
1224-8M-450SL	450	6.652
1240-8M-450SL	450	6.739
1248-8M-450SL	450	6.782
1256-8M-450SL	450	6.826
1264-8M-450SL	450	6.869
1272-8M-450SL	450	6.913
1280-8M-450SL	450	6.956
1304-8M-450SL	450	7.087
1312-8M-450SL	450	7.130
1320-8M-450SL	450	7.174
1328-8M-450SL	450	7.217
1344-8M-450SL	450	7.304
1352-8M-450SL	450	7.348
1360-8M-450SL	450	7.391
1376-8M-450SL	450	7.478
1392-8M-450SL	450	7.565
1400-8M-440SL	440	7.439

Synchro-Cog® HT Sleeves

Part Number Example: **1600-8M-440SL** = **1600** - **8M** - **440** **SL**
Pitch Length (millimeters) Tooth Pitch (HTD profile) Width (millimeters) Sleeve

Part Number	Sleeve Width (mm)	Sleeve Weight (lbs)
8M Pitch – High Torque Synchronous (HTS) Sprockets: MPB, QD, Taper Bushed (8mm)		
1424-8M-440SL	440	7.567
1440-8M-440SL	440	7.652
1456-8M-440SL	440	7.737
1464-8M-440SL	440	7.779
1480-8M-440SL	440	7.864
1512-8M-440SL	440	8.034
1520-8M-440SL	440	8.077
1552-8M-440SL	440	8.247
1560-8M-440SL	440	8.290
1576-8M-440SL	440	8.375
1584-8M-440SL	440	8.417
1600-8M-440SL	440	8.502
1640-8M-440SL	440	8.715
1648-8M-440SL	440	8.757
1680-8M-440SL	440	8.927
1696-8M-440SL	400	8.193
1728-8M-440SL	440	9.182
1744-8M-440SL	440	9.267
1752-8M-440SL	440	9.310
1760-8M-440SL	440	9.352
1784-8M-440SL	440	9.480
1792-8M-440SL	440	9.522
1800-8M-440SL	440	9.565
1840-8M-440SL	440	9.777
1856-8M-440SL	440	9.862
1896-8M-440SL	440	10.075
1904-8M-440SL	440	10.117
1920-8M-440SL	440	10.203
1928-8M-440SL	440	10.245
1936-8M-440SL	440	10.288
1952-8M-440SL	440	10.373
1992-8M-440SL	440	10.585
2000-8M-440SL	440	10.628

Part Number	Sleeve Width (mm)	Sleeve Weight (lbs)
8M Pitch – High Torque Synchronous (HTS) Sprockets: MPB, QD, Taper Bushed (8mm)		
2056-8M-440SL	440	10.925
2080-8M-440SL	440	11.053
2104-8M-440SL	440	11.180
2136-8M-440SL	440	11.350
2160-8M-440SL	440	11.478
2208-8M-440SL	440	11.733
2240-8M-440SL	440	11.903
2272-8M-440SL	440	12.073
2304-8M-440SL	440	12.243
2328-8M-440SL	440	12.371
2392-8M-440SL	440	12.711
2400-8M-440SL	440	12.753
2504-8M-440SL	440	13.306
2584-8M-440SL	440	13.731
2600-8M-440SL	440	13.816
2656-8M-440SL	440	14.113
2736-8M-440SL	440	14.539
2800-8M-440SL	440	14.879
3048-8M-440SL	440	16.196
3120-8M-440SL	440	16.579
3168-8M-440SL	440	16.834
3200-8M-440SL	440	17.004
3280-8M-440SL	440	17.429
3400-8M-440SL	440	18.067
3600-8M-440SL	440	19.130
3824-8M-440SL	440	20.320
4000-8M-440SL	440	21.255
4400-8M-180SL	180	9.565
5120-8M-240SL	240	14.840
5576-8M-440SL	440	29.630
5600-8M-440SL	440	29.757
5960-8M-240SL	240	17.275

Continued on next page

Synchro-Cog® HT

Sleeves

Synchro-Cog® HT Sleeve Part Numbers

Part Number Example: **1400-14M-440SL** = **1400** - **14M** - **440** **SL**
Pitch Length (millimeters) Tooth Pitch (HTD profile) Width (millimeters) Sleeve

Part Number	Sleeve Width (mm)	Sleeve Weight (lbs)
14M Pitch – High Torque Synchronous (HTS) Sprockets: MPB, OD, Taper Bushed (14mm)		
966-14M-440SL	440	8.323
1036-14M-440SL	440	8.927
1092-14M-440SL	440	9.409
1120-14M-440SL	440	9.650
1148-14M-440SL	440	9.892
1190-14M-440SL	440	10.253
1246-14M-440SL	440	10.736
1260-14M-440SL	440	10.857
1316-14M-440SL	440	11.339
1344-14M-440SL	440	11.580
1400-14M-440SL	440	12.063
1442-14M-440SL	440	12.425
1456-14M-440SL	440	12.545
1470-14M-440SL	440	12.666
1540-14M-440SL	440	13.269
1568-14M-440SL	440	13.510
1610-14M-440SL	440	13.872
1652-14M-440SL	440	14.234
1750-14M-440SL	440	15.079
1764-14M-440SL	440	15.199
1778-14M-440SL	440	15.320
1792-14M-440SL	440	15.440
1806-14M-440SL	440	15.561
1820-14M-440SL	440	15.682
1890-14M-440SL	440	16.285
1932-14M-440SL	440	16.647
1960-14M-440SL	440	16.888
2100-14M-440SL	440	18.094
2240-14M-440SL	440	19.301
2310-14M-440SL	440	19.904
2450-14M-440SL	440	21.110
2590-14M-440SL	440	22.316
2660-14M-440SL	440	22.919

Part Number	Sleeve Width (mm)	Sleeve Weight (lbs)
14M Pitch – High Torque Synchronous (HTS) Sprockets: MPB, OD, Taper Bushed (14mm)		
2800-14M-440SL	440	24.126
3108-14M-430SL	430	26.171
3150-14M-430SL	430	26.525
3304-14M-430SL	430	27.821
3360-14M-430SL	430	28.293
3500-14M-430SL	430	29.472
3668-14M-430SL	430	30.886
3850-14M-430SL	430	32.419
4326-14M-350SL	350	29.650
4536-14M-430SL	430	38.195
4578-14M-230SL	230	20.619
4956-14M-430SL	430	41.732
5320-14M-430SL	430	44.797
5740-14M-430SL	430	48.334
6160-14M-430SL	430	51.870
6860-14M-430SL	430	57.765

Dual Synchronous Synchronous Drive Belt

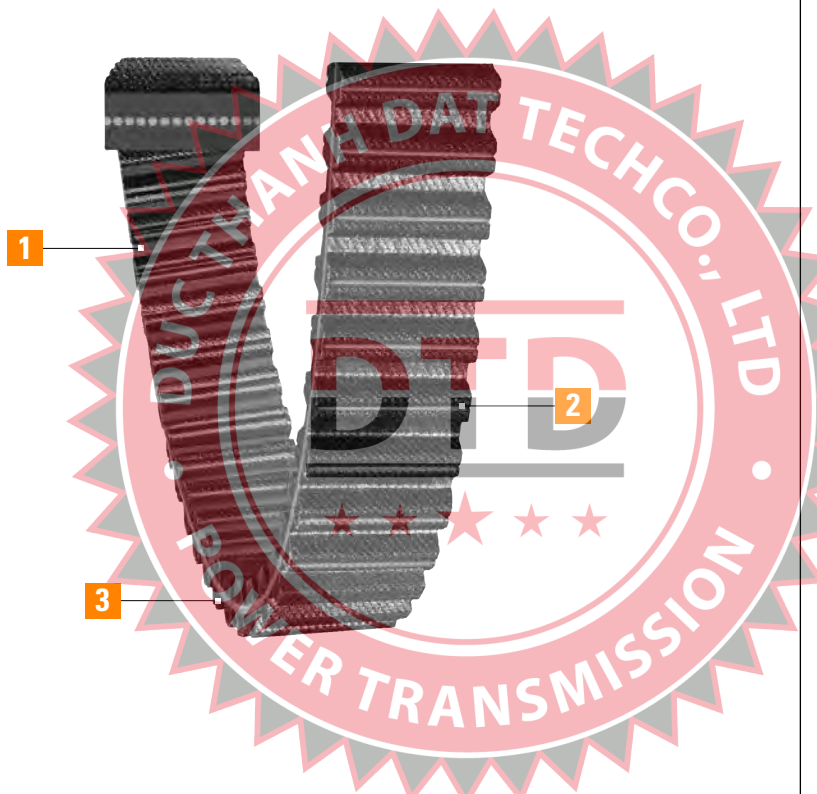

1 Molded Tooth Construction
Provides greater shear resistance and load capacity.

2 RPP® Profile
Tooth design allows for smoother, quieter operation.

3 Load Capacity
100% on both sides of belt.

- Superior performance
- Smaller, more compact system
- Reduced drive weight and space
- 100% load capacity on both sides

- Applications:**
- Printing presses
 - Mixers
 - Agitators
 - Machine tools
 - Robotics
 - Sewing machines
 - Vending machines
 - & More

Recommended Sprockets:
High Torque Synchronous Sprockets – MPB, QD, Taper Bushed (8mm, 14mm)

Synchronous Belts

Dual Synchronous Synchronous Drive Belt

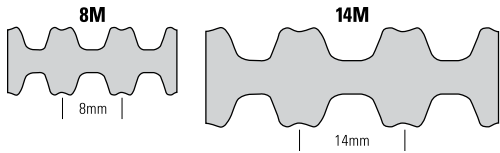

Proven performance from both sides of the belt for greater flexibility and efficiency in your drive design.

The Dual Synchronous Belt yields proven performance in a double sided design providing maintenance-free synchronization from both sides of the belt.

Molded teeth provide excellent shear resistance and resistance to tooth jump.

The manufacturing process allows for equal load capacity on both sides of the belt, a feature not found in many dual sided belts on the market.

Achieve greater drive design flexibility and efficiency with the Dual Synchronous Belt.

Choose Dual Synchronous Belts for a compact, efficient, quiet, and smoother running drive.

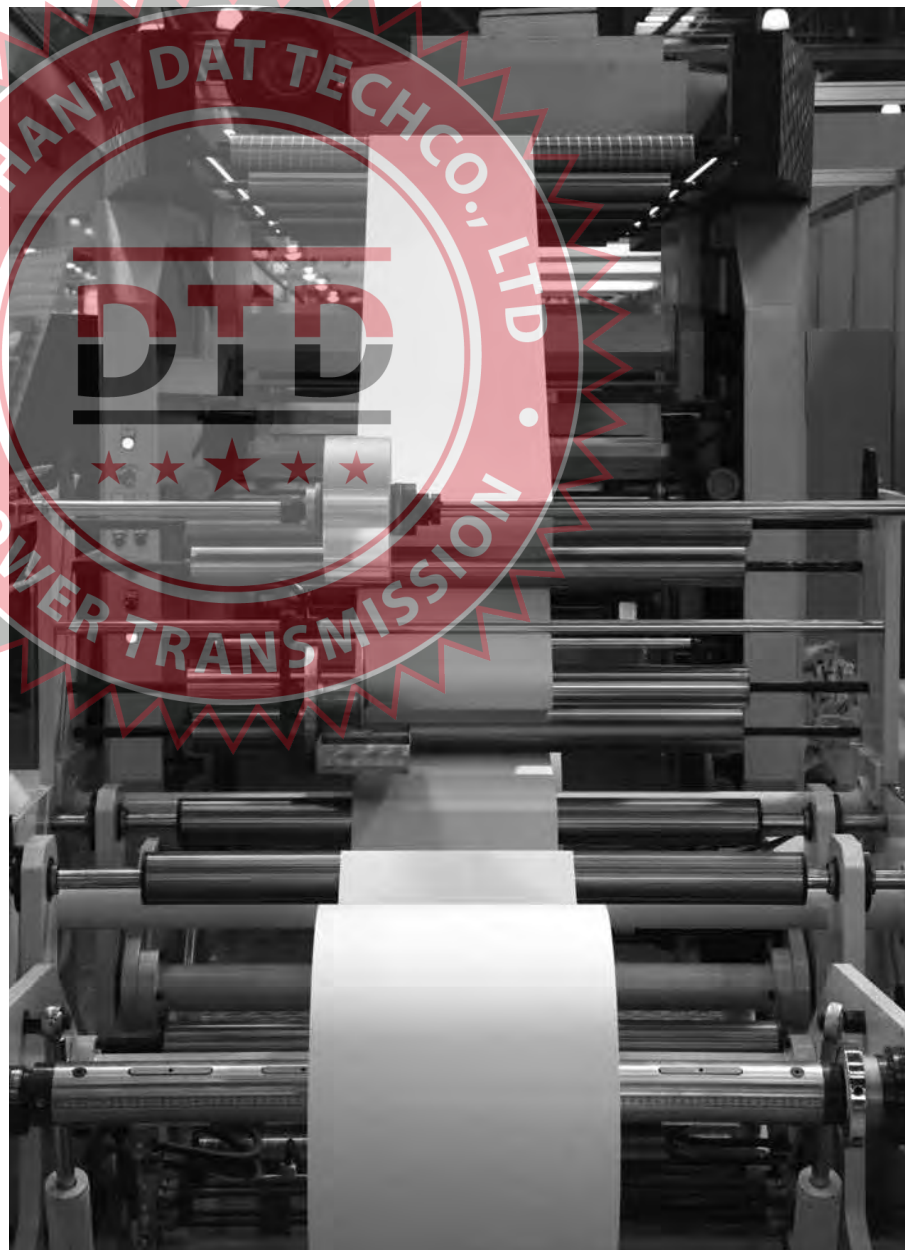

Dual Synchronous Synchronous Drive Belt

Dual Synchronous Part Numbers

Part Number Example: **D1200-8M-50** =
D **1200** - **8M** - **50**
Dual Sided Construction Pitch Length (millimeters) Tooth Pitch (RPP tooth profile) Width (millimeters)

Part Number	Number Of Teeth	Pitch Length		Weight (lbs)
		(mm)	(in)	
8M Pitch – High Torque Synchronous (HTS) Sprockets: MPB, QD, Taper Bushed (8mm)				
D720-8M-20	90	720	28.00	0.23
D720-8M-30	90	720	28.00	0.35
D720-8M-50	90	720	28.00	0.58
D720-8M-85	90	720	28.00	0.98
D800-8M-20	100	800	32.00	0.26
D800-8M-30	100	800	32.00	0.38
D800-8M-50	100	800	32.00	0.64
D800-8M-85	100	800	32.00	1.09
D840-8M-20	105	840	33.00	0.27
D840-8M-30	105	840	33.00	0.40
D840-8M-50	105	840	33.00	0.67
D840-8M-85	105	840	33.00	1.14
D880-8M-20	110	880	35.00	0.28
D880-8M-30	110	880	35.00	0.42
D880-8M-50	110	880	35.00	0.71
D880-8M-85	110	880	35.00	1.20
D920-8M-20	115	920	36.20	0.29
D920-8M-30	115	920	36.20	0.44
D920-8M-50	115	920	36.20	0.74
D920-8M-85	115	920	36.20	1.25
D960-8M-20	120	960	38.00	0.31
D960-8M-30	120	960	38.00	0.46
D960-8M-50	120	960	38.00	0.77
D960-8M-85	120	960	38.00	1.31
D1040-8M-20	130	1040	41.00	0.33
D1040-8M-30	130	1040	41.00	0.50
D1040-8M-50	130	1040	41.00	0.83
D1040-8M-85	130	1040	41.00	1.42
D1120-8M-20	140	1120	44.00	0.36
D1120-8M-30	140	1120	44.00	0.54
D1120-8M-50	140	1120	44.00	0.90
D1120-8M-85	140	1120	44.00	1.53
D1200-8M-20	150	1200	47.00	0.38

Part Number	Number Of Teeth	Pitch Length		Weight (lbs)
		(mm)	(in)	
8M Pitch – High Torque Synchronous (HTS) Sprockets: MPB, QD, Taper Bushed (8mm)				
D1200-8M-30	150	1200	47.00	0.58
D1200-8M-50	150	1200	47.00	0.96
D1200-8M-85	150	1200	47.00	1.63
D1280-8M-20	160	1280	50.00	0.41
D1280-8M-30	160	1280	50.00	0.62
D1280-8M-50	160	1280	50.00	1.03
D1280-8M-85	160	1280	50.00	1.74
D1440-8M-20	180	1440	57.00	0.46
D1440-8M-30	180	1440	57.00	0.69
D1440-8M-50	180	1440	57.00	1.15
D1440-8M-85	180	1440	57.00	1.96
D1600-8M-20	200	1600	63.00	0.51
D1600-8M-30	200	1600	63.00	0.77
D1600-8M-50	200	1600	63.00	1.28
D1600-8M-85	200	1600	63.00	2.18
D1760-8M-20	220	1760	69.00	0.56
D1760-8M-30	220	1760	69.00	0.85
D1760-8M-50	220	1760	69.00	1.41
D1760-8M-85	220	1760	69.00	2.40
D1800-8M-20	225	1800	71.00	0.58
D1800-8M-30	225	1800	71.00	0.87
D1800-8M-50	225	1800	71.00	1.44
D1800-8M-85	225	1800	71.00	2.45
D2000-8M-20	250	2000	79.00	0.64
D2000-8M-30	250	2000	79.00	0.96
D2000-8M-50	250	2000	79.00	1.60
D2000-8M-85	250	2000	79.00	2.72
D2200-8M-20	275	2200	86.60	0.71
D2200-8M-30	275	2200	86.60	1.06
D2200-8M-50	275	2200	86.60	1.76
D2200-8M-85	275	2200	86.60	3.00
D2400-8M-20	300	2400	94.00	0.77
D2400-8M-30	300	2400	94.00	1.15

Synchronous Belts

Dual Synchronous

Synchronous Drive Belt

Dual Synchronous Part Numbers

Part Number	Number Of Teeth	Pitch Length		Weight (lbs)
		(mm)	(in)	
8M Pitch – High Torque Synchronous (HTS) Sprockets: MPB, QD, Taper Bushed (8mm)				
D2400-8M-50	300	2400	94.00	1.92
D2400-8M-85	300	2400	94.00	3.27
D2600-8M-20	325	2600	102.00	0.83
D2600-8M-30	325	2600	102.00	1.25
D2600-8M-50	325	2600	102.00	2.08
D2600-8M-85	325	2600	102.00	3.54
D2800-8M-20	350	2800	110.00	0.90
D2800-8M-30	350	2800	110.00	1.35
D2800-8M-50	350	2800	110.00	2.24
D2800-8M-85	350	2800	110.00	3.81
D3048-8M-20	381	3048	120.00	0.98
D3048-8M-30	381	3048	120.00	1.47
D3048-8M-50	381	3048	120.00	2.44
D3048-8M-85	381	3048	120.00	4.15
D3280-8M-20	410	3280	129.00	1.05
D3280-8M-30	410	3280	129.00	1.58
D3280-8M-50	410	3280	129.00	2.63
D3280-8M-85	410	3280	129.00	4.47
D3600-8M-20	450	3600	142.00	1.15
D3600-8M-30	450	3600	142.00	1.73
D3600-8M-50	450	3600	142.00	2.89
D3600-8M-85	450	3600	142.00	4.90
D4400-8M-20	550	4400	173.00	1.41
D4400-8M-30	550	4400	173.00	2.12
D4400-8M-50	550	4400	173.00	3.53
D4400-8M-85	550	4400	173.00	5.99
14M Pitch – High Torque Synchronous Sprockets: MPB, QD, Taper Bushed (14mm)				
D966-14M-115	69	966	38.00	2.86
D966-14M-170	69	966	38.00	4.22
D966-14M-40	69	966	38.00	0.99
D966-14M-55	69	966	38.00	1.37
D966-14M-85	69	966	38.00	2.11

Part Number	Number Of Teeth	Pitch Length		Weight (lbs)
		(mm)	(in)	
14M Pitch – High Torque Synchronous (HTS) Sprockets: MPB, QD, Taper Bushed (14mm)				
D1190-14M-115	85	1190	46.90	3.52
D1190-14M-170	85	1190	46.90	5.20
D1190-14M-40	85	1190	46.90	1.22
D1190-14M-55	85	1190	46.90	1.68
D1190-14M-85	85	1190	46.90	2.60
D1400-14M-115	100	1400	55.00	4.14
D1400-14M-170	100	1400	55.00	6.12
D1400-14M-40	100	1400	55.00	1.44
D1400-14M-55	100	1400	55.00	1.98
D1400-14M-85	100	1400	55.00	3.06
D1610-14M-115	115	1610	63.00	4.76
D1610-14M-170	115	1610	63.00	7.04
D1610-14M-40	115	1610	63.00	1.66
D1610-14M-55	115	1610	63.00	2.28
D1610-14M-85	115	1610	63.00	3.52
D1778-14M-115	127	1778	70.00	5.26
D1778-14M-170	127	1778	70.00	7.77
D1778-14M-40	127	1778	70.00	1.83
D1778-14M-55	127	1778	70.00	2.51
D1778-14M-85	127	1778	70.00	3.88
D1890-14M-115	135	1890	74.00	5.59
D1890-14M-170	135	1890	74.00	8.26
D1890-14M-40	135	1890	74.00	1.94
D1890-14M-55	135	1890	74.00	2.67
D1890-14M-85	135	1890	74.00	4.13
D2100-14M-115	150	2100	83.00	6.21
D2100-14M-170	150	2100	83.00	9.18
D2100-14M-40	150	2100	83.00	2.16
D2100-14M-55	150	2100	83.00	2.97
D2100-14M-85	150	2100	83.00	4.59
D2310-14M-115	165	2310	91.00	6.83
D2310-14M-170	165	2310	91.00	10.09
D2310-14M-40	165	2310	91.00	2.38

Dual Synchronous Synchronous Drive Belt

Part Number Example: **D2400-8M-50** = **D** **2400** - **8M** - **50**
Dual Sided Cog Construction Pitch Length (millimeters) Tooth Pitch (RPP tooth profile) Width (millimeters)

Part Number	Number Of Teeth	Pitch Length		Weight (lbs)
		(mm)	(in)	
14M Pitch – High Torque Synchronous (HTS) Sprockets: MPB, QD, Taper Bushed (14mm)				
D2310-14M-55	165	2310	91.00	3.27
D2310-14M-85	165	2310	91.00	5.05
D2450-14M-115	175	2450	96.00	7.24
D2450-14M-170	175	2450	96.00	10.71
D2450-14M-40	175	2450	96.00	2.52
D2450-14M-55	175	2450	96.00	3.46
D2450-14M-85	175	2450	96.00	5.35
D2590-14M-115	185	2590	102.00	7.66
D2590-14M-170	185	2590	102.00	11.32
D2590-14M-40	185	2590	102.00	2.66
D2590-14M-55	185	2590	102.00	3.66
D2590-14M-85	185	2590	102.00	5.66
D2800-14M-115	200	2800	110.00	8.28
D2800-14M-170	200	3150	110.00	12.24
D2800-14M-40	200	2800	110.00	2.88
D2800-14M-55	200	2800	110.00	3.96
D2800-14M-85	200	2800	110.00	6.12
D3150-14M-115	225	3150	124.00	9.31
D3150-14M-170	225	3360	124.00	13.76
D3150-14M-40	225	3150	124.00	3.24
D3150-14M-55	225	3150	124.00	4.45
D3150-14M-85	225	3150	124.00	6.88
D3360-14M-115	240	3360	132.00	9.93
D3360-14M-170	240	3360	132.00	14.68
D3360-14M-40	240	3360	132.00	3.45
D3360-14M-55	240	3360	132.00	4.75
D3360-14M-85	240	3360	132.00	7.34
D3500-14M-115	250	3500	138.00	10.35
D3500-14M-170	250	3500	138.00	15.29
D3500-14M-40	250	3500	138.00	3.60
D3500-14M-55	250	3500	138.00	4.95
D3500-14M-85	250	3500	138.00	7.65
D3850-14M-115	275	3850	152.00	11.38

Part Number	Number Of Teeth	Pitch Length		Weight (lbs)
		(mm)	(in)	
14M Pitch – High Torque Synchronous (HTS) Sprockets: MPB, QD, Taper Bushed (14mm)				
D3850-14M-170	275	3850	152.00	16.82
D3850-14M-40	275	3850	152.00	3.96
D3850-14M-55	275	3850	152.00	5.44
D3850-14M-85	275	3850	152.00	8.41
D4326-14M-115	309	4326	170.00	12.79
D4326-14M-170	309	4326	170.00	18.90
D4326-14M-40	309	4326	170.00	4.45
D4326-14M-55	309	4326	170.00	6.12
D4326-14M-85	309	4326	170.00	9.45
D4578-14M-115	327	4578	180.00	13.53
D4578-14M-170	327	4578	180.00	20.01
D4578-14M-40	327	4578	180.00	0.47
D4578-14M-55	327	4578	180.00	6.47
D4578-14M-85	327	4578	180.00	10.00
D4956-14M-115	354	4956	195.00	14.65
D4956-14M-170	354	4956	195.00	21.66
D4956-14M-40	354	4956	195.00	5.10
D4956-14M-55	354	4956	195.00	7.01
D4956-14M-85	354	4956	195.00	10.83

Synchronous Belts

Dual Synchronous Sleeves



- Full factory width sleeves
- All sleeves will have the edges trimmed before shipment
- Cut sleeves cannot be accepted for return
- All weights are approximate

Timken maintains inventory of most Carlisle® sleeve sizes. Non-stock sizes will be indicated by an asterisk following the part number. Contact customer service for availability. Minimum order quantity and/or extended lead times may apply.

Occasional production inconsistencies which may render a portion of the sleeve unusable can be present as a normal part of the production process.

Each sleeve is inspected to ensure that it contains 90% or more usable product. A full width sleeve with less than 10% unusable product is considered acceptable.

Dual Synchronous Sleeve Part Numbers

Part Number	Sleeve Width (mm)	Sleeve Weight (lbs)
8M Pitch – High Torque Synchronous (HTS) Sprockets: MPB, OD, Taper Bushed (8mm)		
D720-8M-150SL	150	1.73
D800-8M-150SL	150	1.92
D840-8M-150SL	150	2.02
D880-8M-150SL	150	2.12
D920-8M-150SL	150	2.21
D960-8M-215SL	215	3.31
D1040-8M-215SL	215	3.58
D1120-8M-215SL	215	3.86
D1200-8M-215SL	215	4.14
D1224-8M-150SL	150	4.22
D1280-8M-215SL	215	4.41
D1440-8M-215SL	215	4.96
D1600-8M-215SL	215	5.51
D1760-8M-215SL	215	6.07
D1800-8M-215SL	215	6.20
D2000-8M-215SL	215	6.89
D2200-8M-215SL	215	7.58
D2400-8M-215SL	215	8.27
D2600-8M-215SL	215	8.96
D2800-8M-215SL	215	9.65
D3048-8M-215SL	215	10.50
D3280-8M-215SL	215	11.30
D3600-8M-215SL	215	12.41
D4400-8M-215SL	215	15.16

Dual Synchronous Sleeves

Part Number Example: **D1200-8M-215SL** = **D** - **1200** **8M** - **215** **SL**
Dual Sided Cog Construction Pitch Length (millimeters) Tooth Pitch (RPP tooth profile) Width (millimeters) Sleeve

Part Number	Sleeve Width (mm)	Sleeve Weight (lbs)
14M Pitch – High Torque Synchronous (HTS) Sprockets: MPB, OD, Taper Bushed (14mm)		
D966-14M-170SL	170	4.22
D1190-14M-170SL	170	5.20
D1400-14M-215SL	215	7.74
D1610-14M-215SL	215	8.90
D1778-14M-215SL	215	9.83
D1890-14M-215SL	215	10.45
D2100-14M-215SL	215	11.61
D2310-14M-215SL	215	12.77
D2450-14M-215SL	215	13.54
D2590-14M-215SL	215	14.31
D2800-14M-215SL	215	15.47
D3150-14M-215SL	215	17.41
D3360-14M-215SL	215	18.57
D3500-14M-215SL	215	19.34
D3850-14M-215SL	215	21.28
D4326-14M-215SL	215	23.91
D4578-14M-215SL	215	25.30
D4956-14M-215SL	215	27.39

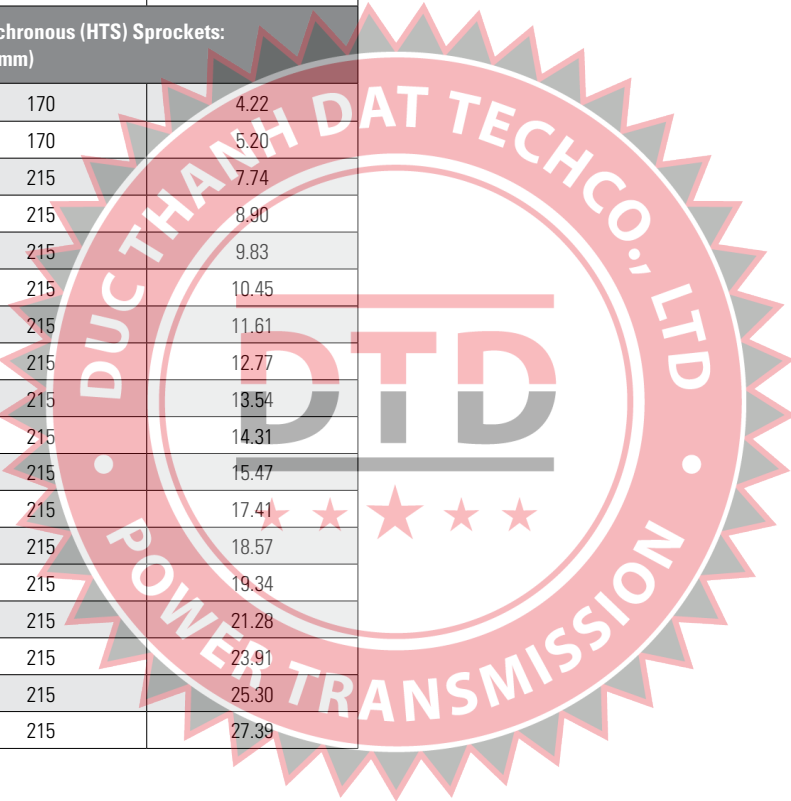

Synchronous Belts

Synchro-Cog® Timing Belt

Synchronous Drive Belt



Synchro-Cog® Timing Belt

Synchronous Drive Belt

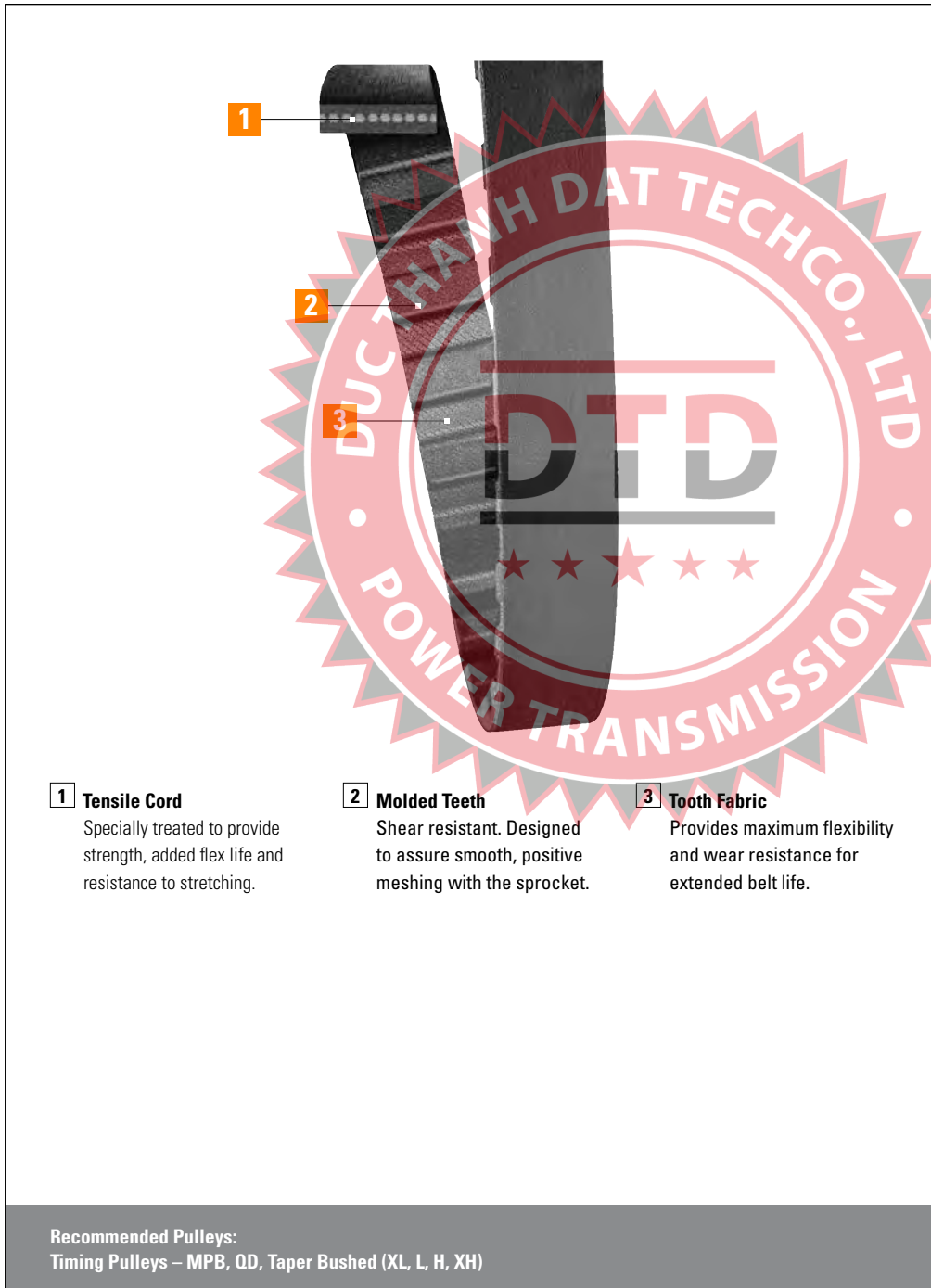

1 Tensile Cord
Specially treated to provide strength, added flex life and resistance to stretching.

2 Molded Teeth
Shear resistant. Designed to assure smooth, positive meshing with the sprocket.

3 Tooth Fabric
Provides maximum flexibility and wear resistance for extended belt life.

Recommended Pulleys:
Timing Pulleys – MPB, OD, Taper Bushed (XL, L, H, XH)

Trapezoidal tooth profile

Perfect synchronization between driver and driven units

Low maintenance

Long life

Clean and quiet

Applications:

- Machine tools
- Sewing machines
- Packaging equipment
- Vending machines
- Food processing equipment
- & More

Synchronous Belts

Synchro-Cog® Timing

Synchronous Drive Belt

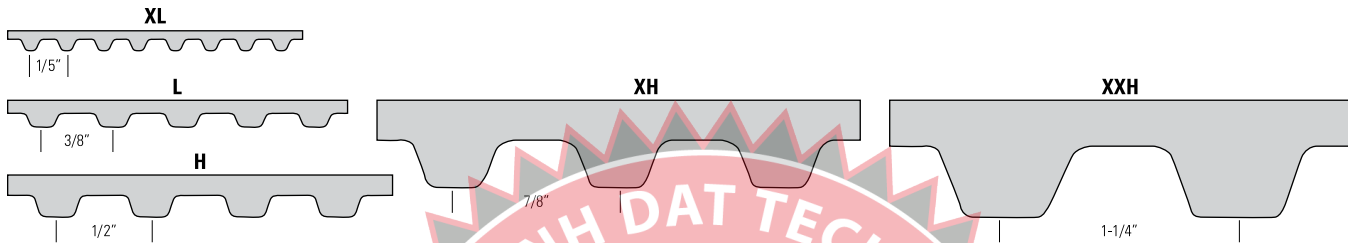

The Synchro-Cog® Timing Belt has a trapezoidal tooth profile for applications where synchronization between the driving and driven units is required.

The first synchronous belts had a trapezoidal tooth profile and are often called timing belts. Synchro-Cog® timing belts are an excellent choice for energy efficient, low maintenance performance on positive drive applications.

Synchro-Cog provides a wide range of load capacities and speeds. Belts are oil, heat, and abrasion resistant. No lubrication is required so you can enjoy clean, maintenance free performance.

Synchro-Cog is ideal for use in positioning applications or on inaccessible drives where maintenance is difficult. Synchro-Cog eliminates lubrication and re-tensioning, and provides a long service life.



Synchro-Cog trapezoidal timing belts are available in the following pitches:	XL	=	Extra Light	(0.200" pitch)
	L	=	Light	(0.375" pitch)
	H	=	Heavy	(0.500" pitch)
	XH	=	Extra Heavy	(0.875" pitch)
	XXH	=	Double Extra Heavy	(1.250" pitch)

Synchro-Cog® Timing Belt

Synchronous Drive Belt

Synchro-Cog® Timing Belt Part Numbers

Part Number Example: **210XL037** =

210
XL
037

Pitch Length
(inches in tenths: 21.0")
Tooth Pitch
(inches)
Width
(inches in tenths: 0.37")

Part Number	Number of Teeth	Pitch Length (in)	Weight (lbs)
XL (1/5") Pitch – Recommended Pulleys: Timing Pulleys – MPB, QD, Taper Bushed (XL)			
50XL025	25	5.0	0.01
50XL037	25	5.0	0.01
60XL025	30	6.0	0.05
60XL037	30	6.0	0.08
70XL025	35	7.0	0.01
70XL037	35	7.0	0.01
80XL025	40	8.0	0.01
80XL037	40	8.0	0.01
90XL025	45	9.0	0.01
90XL037	45	9.0	0.01
100XL025	50	10.0	0.01
100XL037	50	10.0	0.01
110XL025	55	11.0	0.01
110XL037	55	11.0	0.01
120XL025	60	12.0	0.01
120XL037	60	12.0	0.02
130XL025	65	13.0	0.01
130XL037	65	13.0	0.02
140XL025	70	14.0	0.01
140XL037	70	14.0	0.02
150XL025	75	15.0	0.01
150XL037	75	15.0	0.02
160XL025	80	16.0	0.01
160XL037	80	16.0	0.02
170XL025	85	17.0	0.02
170XL037	85	17.0	0.02
180XL025	90	18.0	0.02
180XL037	90	18.0	0.02
190XL025	95	19.0	0.02
190XL037	95	19.0	0.03
200XL025	100	20.0	0.02
200XL037	100	20.0	0.03
210XL025	105	21.0	0.02

Part Number	Number of Teeth	Pitch Length (in)	Weight (lbs)
XL (1/5") Pitch – Recommended Pulleys: Timing Pulleys – MPB, QD, Taper Bushed (XL)			
210XL037	105	21.0	0.03
220XL025	110	22.0	0.02
220XL037	110	22.0	0.00
230XL025	115	23.0	0.02
230XL037	115	23.0	0.03
240XL025	120	24.0	0.02
240XL037	120	24.0	0.03
250XL025	125	25.0	0.02
250XL037	125	25.0	0.03
260XL025	130	26.0	0.02
260XL037	130	26.0	0.03
280XL025	140	28.0	0.03
280XL037	140	28.0	0.04
290XL025	145	29.0	0.03
290XL037	145	29.0	0.04
300XL025	150	30.0	0.03
300XL037	150	30.0	0.04
310XL025	155	31.0	0.03
310XL037	155	31.0	0.04
330XL025	165	33.0	0.03
330XL037	165	33.0	0.04
340XL025	170	34.0	0.03
340XL037	170	34.0	0.04
350XL025	175	35.0	0.03
350XL037	175	35.0	0.05
370XL025	185	37.0	0.03
370XL037	185	37.0	0.05
380XL025	190	38.0	0.03
380XL037	190	38.0	0.05
390XL025	195	39.0	0.03
390XL037	195	39.0	0.05
400XL025	200	40.0	0.04
400XL037	200	40.0	0.05

Synchronous Belts

Synchro-Cog® Timing Belt

Synchronous Drive Belt

Synchro-Cog® Timing Belt Part Numbers

Part Number	Number of Teeth	Pitch Length (in)	Weight (lbs)
XL (1/5") Pitch – Recommended Pulleys: Timing Pulleys – MPB, QD, Taper Bushed (XL)			
420XL025	210	42.0	0.04
420XL037	210	42.0	0.06
450XL025	225	45.0	0.04
450XL037	225	45.0	0.06
460XL025	230	46.0	0.04
460XL037	230	46.0	0.06
480XL025	240	48.0	0.10
480XL037	240	48.0	0.06
570XL025	285	57.0	0.05
570XL037	285	57.0	0.08
630XL025	315	63.0	0.06
630XL037	315	63.0	0.08
L (3/8") Pitch – Recommended Pulleys: Timing Pulleys – MPB, QD, Taper Bushed (L)			
124L050	33	12.4	0.03
124L075	33	12.4	0.05
124L100	33	12.4	0.06
135L050	36	13.5	0.03
135L075	36	13.5	0.05
135L100	36	13.5	0.07
150L050	40	15.0	0.04
150L075	40	15.0	0.06
150L100	40	15.0	0.08
165L050	44	16.5	0.04
165L075	44	16.5	0.06
165L100	44	16.5	0.08
187L050	50	18.8	0.05
187L075	50	18.8	0.07
187L100	50	18.8	0.09
195L050	52	19.5	0.05
195L075	52	19.5	0.07
195L100	52	19.5	0.10
210L050	56	21.0	0.05

Part Number	Number of Teeth	Pitch Length (in)	Weight (lbs)
L (3/8") Pitch – Recommended Pulleys: Timing Pulleys – MPB, QD, Taper Bushed (L)			
210L075	56	21.0	0.08
210L100	56	21.0	0.11
225L050	60	22.5	0.06
225L075	60	22.5	0.09
225L100	60	22.5	0.11
240L050	64	24.0	0.06
240L075	64	24.0	0.09
240L100	64	24.0	0.12
255L050	68	25.5	0.06
255L075	68	25.5	0.10
255L100	68	25.5	0.13
270L050	72	27.0	0.07
270L075	72	27.0	0.10
270L100	72	27.0	0.14
285L050	76	28.5	0.07
285L075	76	28.5	0.11
285L100	76	28.5	0.14
300L050	80	30.0	0.08
300L075	80	30.0	0.11
300L100	80	30.0	0.15
315L050	84	31.5	0.08
315L075	84	31.5	0.12
315L100	84	31.5	0.16
322L050	86	32.3	0.08
322L075	86	32.3	0.12
322L100	86	32.3	0.16
345L050	92	34.5	0.09
345L075	92	34.5	0.13
345L100	92	34.5	0.17
367L050	98	36.8	0.09
367L075	98	36.8	0.14
367L100	98	36.8	0.19
390L050	104	39.0	0.10

Synchro-Cog® Timing Belt

Synchronous Drive Belt

Part Number Example: **300H100** = **300** **H** **100**
Pitch Length (inches in tenths: 30.0") Tooth Pitch (inches) Width (inches in tenths: 1.00")

Part Number	Number of Teeth	Pitch Length (in)	Weight (lbs)
L (3/8") Pitch – Recommended Pulleys: Timing Pulleys – MPB, QD, Taper Bushed (L)			
390L075	104	39.0	0.15
390L100	104	39.0	0.20
420L050	112	42.0	0.11
420L075	112	42.0	0.16
420L100	112	42.0	0.21
450L050	120	45.0	0.11
450L075	120	45.0	0.17
450L100	120	45.0	0.23
480L050	128	48.0	0.12
480L075	128	48.0	0.18
480L100	128	48.0	0.24
510L050	136	51.0	0.13
510L075	136	51.0	0.19
510L100	136	51.0	0.26
540L050	144	54.0	0.14
540L075	144	54.0	0.20
540L100	144	54.0	0.27
600L050	160	60.0	0.15
600L075	160	60.0	0.23
600L100	160	60.0	0.30
660L050	176	66.0	0.15
660L075	176	66.0	0.25
660L100	176	66.0	0.33
817L050	218	81.8	0.21
817L075	218	81.8	0.31
817L100	218	81.8	0.41
900L050	240	90.0	0.23
900L075	240	90.0	0.34
900L100	240	90.0	0.46
H (1/2") Pitch – Recommended Pulleys: Timing Pulleys – MPB, QD, Taper Bushed (H)			
210H075	42	21.0	0.10
210H100	42	21.0	0.14

Part Number	Number of Teeth	Pitch Length (in)	Weight (lbs)
H (1/2") Pitch – Recommended Pulleys: Timing Pulleys – MPB, QD, Taper Bushed (H)			
210H150	42	21.0	0.21
210H200	42	21.0	0.28
210H300	42	21.0	0.42
220H075	44	22.0	0.11
220H100	44	22.0	0.15
220H150	44	22.0	0.22
220H200	44	22.0	0.29
220H300	44	22.0	0.44
230H075	46	23.0	0.11
230H100	46	23.0	0.15
230H150	46	23.0	0.23
230H200	46	23.0	0.31
230H300	46	23.0	0.46
240H075	48	24.0	0.12
240H100	48	24.0	0.16
240H150	48	24.0	0.24
240H200	48	24.0	0.32
240H300	48	24.0	0.48
270H075	54	27.0	0.13
270H100	54	27.0	0.18
270H150	54	27.0	0.27
270H200	54	27.0	0.36
270H300	54	27.0	0.54
300H075	60	30.0	0.15
300H100	60	30.0	0.20
300H150	60	30.0	0.30
300H200	60	30.0	0.40
300H300	60	30.0	0.60
320H075	64	32.0	0.16
320H100	64	32.0	0.21
320H150	64	32.0	0.32
320H200	64	32.0	0.42
320H300	64	32.0	0.64

Synchronous Belts

Synchro-Cog® Timing Belt

Synchronous Drive Belt

Synchro-Cog® Timing Belt Part Numbers

Part Number	Number of Teeth	Pitch Length (in)	Weight (lbs)
H (1/2") Pitch – Recommended Pulleys: Timing Pulleys – MPB, QD, Taper Bushed (H)			
330H075	66	33.0	0.16
330H100	66	33.0	0.22
330H150	66	33.0	0.33
330H200	66	33.0	0.44
330H300	66	33.0	0.66
340H075	68	34.0	0.17
340H100	68	34.0	0.23
340H150	68	34.0	0.34
340H200	68	34.0	0.45
340H300	68	34.0	0.68
350H075	70	35.0	0.17
350H100	70	35.0	0.23
350H150	70	35.0	0.35
350H200	70	35.0	0.46
350H300	70	35.0	0.70
360H075	72	36.0	0.18
360H100	72	36.0	0.24
360H150	72	36.0	0.36
360H200	72	36.0	0.48
360H300	72	36.0	0.72
370H075	74	37.0	0.18
370H100	74	37.0	0.25
370H150	74	37.0	0.37
370H200	74	37.0	0.49
370H300	74	37.0	0.74
390H075	78	39.0	0.19
390H100	78	39.0	0.26
390H150	78	39.0	0.39
390H200	78	39.0	0.52
390H300	78	39.0	0.78
400H075	80	40.0	0.20
400H100	80	40.0	0.27
400H150	80	40.0	0.40

Part Number	Number of Teeth	Pitch Length (in)	Weight (lbs)
H (1/2") Pitch – Recommended Pulleys: Timing Pulleys – MPB, QD, Taper Bushed (H)			
400H200	80	40.0	0.53
400H300	80	40.0	0.80
410H075	82	41.0	0.20
410H100	82	41.0	0.27
410H150	82	41.0	0.41
410H200	82	41.0	0.54
410H300	82	41.0	0.82
420H075	84	42.0	0.21
420H100	84	42.0	0.28
420H150	84	42.0	0.42
420H200	84	42.0	0.56
420H300	84	42.0	0.84
450H075	90	45.0	0.22
450H100	90	45.0	0.30
450H150	90	45.0	0.45
450H200	90	45.0	0.60
450H300	90	45.0	0.90
480H075	96	48.0	0.24
480H100	96	48.0	0.32
480H150	96	48.0	0.48
480H200	96	48.0	0.64
480H300	96	48.0	0.96
490H075	98	49.0	0.24
490H100	98	49.0	0.33
490H150	98	49.0	0.49
490H200	98	49.0	0.65
490H300	98	49.0	0.98
510H075	102	51.0	0.25
510H100	102	51.0	0.34
510H150	102	51.0	0.51
510H200	102	51.0	0.68
510H300	102	51.0	1.02
540H075	108	54.0	0.27

Synchro-Cog® Timing Belt

Synchronous Drive Belt

Part Number Example: **645H300** = **645** **H** **300**
Pitch Length (inches in tenths: 64.5") Tooth Pitch (inches) Width (inches in tenths: 3.00")

Part Number	Number of Teeth	Pitch Length (in)	Weight (lbs)
H (1/2") Pitch – Recommended Pulleys: Timing Pulleys – MPB, QD, Taper Bushed (H)			
540H100	108	54.0	0.36
540H150	108	54.0	0.54
540H200	108	54.0	0.72
540H300	108	54.0	1.08
560H075	112	56.0	0.28
560H100	112	56.0	0.37
560H150	112	56.0	0.56
560H200	112	56.0	0.74
560H300	112	56.0	1.12
570H075	114	57.0	0.28
570H100	114	57.0	0.38
570H150	114	57.0	0.57
570H200	114	57.0	0.76
570H300	114	57.0	1.14
585H075	117	58.5	0.29
585H100	117	58.5	0.39
585H150	117	58.5	0.58
585H200	117	58.5	0.78
585H300	117	58.5	1.16
600H075	120	60.0	0.30
600H100	120	60.0	0.40
600H150	120	60.0	0.60
600H200	120	60.0	0.80
600H300	120	60.0	1.19
630H075	126	63.0	0.31
630H100	126	63.0	0.42
630H150	126	63.0	0.63
630H200	126	63.0	0.84
630H300	126	63.0	1.25
645H075	129	64.5	0.32
645H100	129	64.5	0.43
645H150	129	64.5	0.64
645H200	129	64.5	0.86

Part Number	Number of Teeth	Pitch Length (in)	Weight (lbs)
H (1/2") Pitch – Recommended Pulleys: Timing Pulleys – MPB, QD, Taper Bushed (H)			
645H300	129	64.5	1.28
660H075	132	66.0	0.33
660H100	132	66.0	0.44
660H150	132	66.0	0.66
660H200	132	66.0	0.88
660H300	132	66.0	1.31
700H075	140	70.0	0.35
700H100	140	70.0	0.46
700H150	140	70.0	0.70
700H200	140	70.0	0.93
700H300	140	70.0	1.39
730H075	146	73.0	0.36
730H100	146	73.0	0.48
730H150	146	73.0	0.73
730H200	146	73.0	0.97
730H300	146	73.0	1.45
750H075	150	75.0	0.37
750H100	150	75.0	0.50
750H150	150	75.0	0.75
750H200	150	75.0	1.00
750H300	150	75.0	1.49
780H075	156	78.0	0.39
780H100	156	78.0	0.52
780H150	156	78.0	0.78
780H200	156	78.0	1.04
780H300	156	78.0	1.55
800H075	160	80.0	0.40
800H100	160	80.0	0.53
800H150	160	80.0	0.80
800H200	160	80.0	1.06
800H300	160	80.0	1.59
820H075	164	82.0	0.41
820H100	164	82.0	0.54

Synchronous Belts

Synchro-Cog® Timing Belt

Synchronous Drive Belt

Synchro-Cog® Timing Belt Part Numbers

Part Number	Number of Teeth	Pitch Length (in)	Weight (lbs)
H (1/2") Pitch – Recommended Pulleys: Timing Pulleys – MPB, QD, Taper Bushed (H)			
820H150	164	82.0	0.82
820H200	164	82.0	1.09
820H300	164	82.0	1.63
840H075	168	84.0	0.42
840H100	168	84.0	0.56
840H150	168	84.0	0.84
840H200	168	84.0	1.12
840H300	168	84.0	1.67
850H075	170	85.0	0.42
850H100	170	85.0	0.56
850H150	170	85.0	0.85
850H200	170	85.0	1.13
850H300	170	85.0	1.69
900H075	180	90.0	0.45
900H100	180	90.0	0.60
900H150	180	90.0	0.90
900H200	180	90.0	1.19
900H300	180	90.0	1.79
960H075	192	96.0	0.48
960H100	192	96.0	0.64
960H150	192	96.0	0.96
960H200	192	96.0	1.27
960H300	192	96.0	1.91
1000H075	200	100.0	0.50
1000H100	200	100.0	0.66
1000H150	200	100.0	1.00
1000H200	200	100.0	1.33
1000H300	200	100.0	1.99
1100H075	220	110.0	0.55
1100H100	220	110.0	0.73
1100H150	220	110.0	1.10
1100H200	220	110.0	1.46
1100H300	220	110.0	2.19

Part Number	Number of Teeth	Pitch Length (in)	Weight (lbs)
H (1/2") Pitch – Recommended Pulleys: Timing Pulleys – MPB, QD, Taper Bushed (H)			
1140H075	228	114.0	0.57
1140H100	228	114.0	0.76
1140H150	228	114.0	1.14
1140H200	228	114.0	1.51
1140H300	228	114.0	2.27
1250H075	250	125.0	0.62
1250H100	250	125.0	0.83
1250H150	250	125.0	1.24
1250H200	250	125.0	1.66
1250H300	250	125.0	2.49
1400H075	280	140.0	0.70
1400H100	280	140.0	0.93
1400H150	280	140.0	1.39
1400H200	280	140.0	1.86
1400H300	280	140.0	2.79
1550H075	310	155.0	0.77
1550H100	310	155.0	1.03
1550H150	310	155.0	1.54
1550H200	310	155.0	2.06
1550H300	310	155.0	3.09
1700H075	340	170.0	0.85
1700H100	340	170.0	1.13
1700H150	340	170.0	1.69
1700H200	340	170.0	2.26
1700H300	340	170.0	3.39
XH (7/8") Pitch – Recommended Pulleys: Timing Pulleys – MPB, QD, Taper Bushed (XH)			
507XH200	58	50.8	1.65
507XH300	58	50.8	2.47
507XH400	58	50.8	3.30
560XH200	64	56.0	1.82
560XH300	64	56.0	2.73
560XH400	64	56.0	3.64

Synchro-Cog® Timing Belt

Synchronous Drive Belt

Part Number Example: **630XH200** = **630** **XH** **200**
Pitch Length (inches in tenths: 63.0") Tooth Pitch (inches) Width (inches in tenths: 2.00")

Part Number	Number of Teeth	Pitch Length (in)	Weight (lbs)
XH (7/8") Pitch – Recommended Pulleys: Timing Pulleys – MPB, QD, Taper Bushed (XH)			
630XH200	72	63.0	2.05
630XH300	72	63.0	3.08
630XH400	72	63.0	4.10
700XH200	80	70.0	2.28
700XH300	80	70.0	3.42
700XH400	80	70.0	4.56
770XH200	88	77.0	2.51
770XH300	88	77.0	3.76
770XH400	88	77.0	5.01
840XH200	96	84.0	2.73
840XH300	96	84.0	4.10
840XH400	96	84.0	5.47
980XH200	112	98.0	3.19
980XH300	112	98.0	4.78
980XH400	112	98.0	6.38
1120XH200	128	112.0	3.64
1120XH300	128	112.0	5.47
1120XH400	128	112.0	7.29
1260XH200	144	126.0	4.10
1260XH300	144	126.0	6.15
1260XH400	144	126.0	8.20
1400XH200	160	140.0	4.56
1400XH300	160	140.0	6.83
1400XH400	160	140.0	9.11
1540XH200	176	154.0	5.01
1540XH300	176	154.0	7.52
1540XH400	176	154.0	10.02
1750XH200	200	175.0	5.69
1750XH300	200	175.0	8.54
1750XH400	200	175.0	11.39

Part Number	Number of Teeth	Pitch Length (in)	Weight (lbs)
XXH (1-1/4") Pitch			
700XXH200	56	70.0	3.00
700XXH300	56	70.0	4.49
700XXH400	56	70.0	5.99
700XXH500	56	70.0	7.49
800XXH200	64	80.0	3.42
800XXH300	64	80.0	5.13
800XXH400	64	80.0	6.85
800XXH500	64	80.0	8.56
900XXH200	72	90.0	3.85
900XXH300	72	90.0	5.78
900XXH400	72	90.0	7.70
900XXH500	72	90.0	9.63
1000XXH200	80	100.0	4.28
1000XXH300	80	100.0	6.42
1000XXH400	80	100.0	8.56
1000XXH500	80	100.0	10.70
1200XXH200	96	120.0	5.13
1200XXH300	96	120.0	7.70
1200XXH400	96	120.0	10.27
1200XXH500	96	120.0	12.84
1400XXH200	112	140.0	5.99
1400XXH300	112	140.0	8.99
1400XXH400	112	140.0	11.98
1400XXH500	112	140.0	14.98
1600XXH200	128	160.0	6.85
1600XXH300	128	160.0	10.27
1600XXH400	128	160.0	13.69
1600XXH500	128	160.0	17.11
1800XXH200	144	180.0	7.70
1800XXH300	144	180.0	11.55
1800XXH400	144	180.0	15.40
1800XXH500	144	180.0	19.25

Synchronous Belts

Synchro-Cog® Timing Belt Sleeves

Synchro-Cog® Timing Belt Sleeve Part Numbers

- Full factory width sleeves
- All sleeves will have the edges trimmed before shipment
- Cut sleeves cannot be accepted for return
- All weights are approximate

Timken maintains inventory of most Carlisle® sleeve sizes. Non-stock sizes will be indicated by an asterisk following the part number. Contact customer service for availability. Minimum order quantity and/or extended lead times may apply.

Occasional production inconsistencies which may render a portion of the sleeve unusable can be present as a normal part of the production process.

Each sleeve is inspected to ensure that it contains 90% or more usable product. A full width sleeve with less than 10% unusable product is considered acceptable.

Part Number	Sleeve Width (in)	Weight (lbs)
XL (1/5") Pitch – Recommended Pulleys: Timing Pulleys – MPB, QD, Taper Bushed (XL)		
60XL1600SL	16.0	0.34
70XL1600SL	16.0	0.40
80XL1600SL	16.0	0.46
90XL1600SL	16.0	0.90
100XL2800SL	28.0	1.00
110XL2800SL	28.0	1.10
120XL2800SL	28.0	1.20
130XL2800SL	28.0	1.30
140XL2800SL	28.0	1.40
150XL2800SL	28.0	1.50
160XL2800SL	28.0	1.60
170XL2800SL	28.0	1.70
180XL1600SL	16.0	1.03
190XL1600SL	16.0	1.09
200XL1600SL	16.0	1.14
210XL1600SL	16.0	1.20
220XL1600SL	16.0	1.26
230XL1600SL	16.0	1.31
240XL1600SL	16.0	1.37
250XL1600SL	16.0	1.43
260XL1600SL	16.0	1.49
290XL2126SL	21.3	2.20
310XL1850SL	18.5	2.05
330XL1850SL	18.5	2.18
390XL1850SL	18.5	2.58
L (3/8") Pitch – Recommended Pulleys: Timing Pulleys – MPB, QD, Taper Bushed (L)		
124L1600SL	16.0	1.00
150L2800SL	28.0	2.12
187L2800SL	28.0	2.65
210L1600SL	16.0	1.70
225L3800SL	38.0	4.32
240L3800SL	38.0	4.61

Synchro-Cog® Timing Belt Sleeves

Part Number Example: **200XL1600SL** = **200** **XL** **1600** **SL**
Pitch Length (inches in tenths: 20.0") Tooth Pitch (inches) Width (inches in tenths: 16.00") Sleeve

Part Number	Sleeve Width (in)	Weight (lbs)
L (3/8") Pitch – Recommended Pulleys: Timing Pulleys – MPB, QD, Taper Bushed (L)		
255L3800SL	38.0	4.90
270L3800SL	38.0	5.19
285L3800SL	38.0	5.48
300L3800SL	38.0	5.77
322L3800SL	38.0	6.19
345L3800SL	38.0	6.63
367L3800SL	38.0	7.05
390L3800SL	38.0	7.50
420L3800SL	38.0	8.07
450L1850SL	18.5	4.21
480L1850SL	18.5	4.49
510L1850SL	18.5	4.77
540L1850SL	18.5	5.05
600L3800SL	38.0	11.53
817L1850SL	18.5	7.65
H (1/2") Pitch – Recommended Pulleys: Timing Pulleys – MPB, QD, Taper Bushed (H)		
240H3800SL	38.0	6.05
270H3800SL	38.0	6.81
300H3800SL	38.0	7.57
330H3800SL	38.0	8.32
360H3800SL	38.0	9.08
390H3800SL	38.0	9.84
420H3800SL	38.0	10.59
450H3800SL	38.0	11.35
480H3800SL	38.0	12.11
510H3800SL	38.0	12.86
540H3800SL	38.0	13.62
570H3800SL	38.0	14.38
600H3800SL	38.0	15.13
630H3800SL	38.0	15.89
660H3800SL	38.0	16.65
700H3800SL	38.0	17.66

Part Number	Sleeve Width (in)	Weight (lbs)
H (1/2") Pitch – Recommended Pulleys: Timing Pulleys – MPB, QD, Taper Bushed (H)		
750H3800SL	38.0	18.92
800H2200SL	22.0	11.68
850H2200SL	22.0	12.41
900H2200SL	22.0	1.19
1000H2200SL	22.0	14.60
1100H2200SL	22.0	15.52
1140H2126SL	21.3	13.62
1250H2200SL	22.0	18.25
1400H2200SL	22.0	20.44
1700H2200SL	22.0	23.99
XH (7/8") Pitch – Recommended Pulleys: Timing Pulleys – MPB, QD, Taper Bushed (XH)		
507XH2126SL	21.3	31.35
560XH3800SL	38.0	34.62
630XH3800SL	38.0	38.95
700XH3800SL	38.0	43.28
770XH3800SL	38.0	47.61
840XH2126SL	21.3	29.06
980XH2200SL	22.0	35.08
1120XH2126SL	21.3	38.74
1260XH2126SL	21.3	43.59
1400XH2126SL	21.3	48.43
1540XH2126SL	21.3	53.27
1750XH2126SL	21.3	60.54
XXH (1-1/4") Pitch		
800XXH2126SL	21.3	36.39
900XXH2126SL	21.3	40.93
1000XXH2126SL	21.3	45.48
1200XXH2126SL	21.3	54.58
1400XXH2126SL	21.3	63.68
1600XXH2126SL	21.3	72.77
1800XXH2126SL	21.3	81.87

Synchronous Belts

Air Cool Heat Exchange

Synchronous Drive Belt



Air Cool Heat Exchange

Synchronous Drive Belt



1 Ultra-Cord® Tensile Member
Z-twist construction
Improved belt life
Higher strength
Reduced tension decay

2 Tooth Indentation
Shock absorbing
Reduced noise

3 Nylon Tooth Facing
Graphite-loaded
Self-lubricating
Wear resistant

4 RPP® Profile
Greater transfer of power
Jump and shear resistant
Reduced sprocket wear

5 Backing
Precision-ground
Smoother operation with backside idler

6 Able Compound
Increased performance
Increased belt life

Recommended Sprockets:
High Torque Synchronous Sprockets – MPB, QD, Taper Bushed (14mm)

Special “Z” twist construction for air cooled heat exchangers

“Z” twist cord construction provides an upward direction of lateral movement which helps keep the belt off of the bottom flanges, reducing excessive wear on the bottom side of the belt.

Applications:
HVAC
Air cooled heat exchangers

Synchronous Belts

Air Cool Heat Exchange

Synchronous Drive Belt

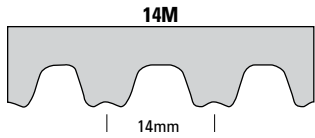

Part Number Example: **3150-14M-55F** =
3150 - **14M** - **55** **F**
Pitch Length (millimeters) Tooth Pitch (RPP tooth profile) Width (millimeters) Z-Twist Cord Construction

Special "Z" twist cord construction for air cooled heat exchange applications.

Air Cool Heat Exchange Belt Part Numbers

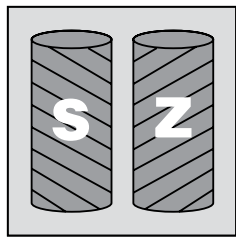

Carlisle® Air Cool Heat Exchange synchronous belts are manufactured using special "Z" twist construction. Because the drive has a vertical shaft, the belt is built with "Z" twist cords only. This gives the belt an upward direction

of lateral movement which reduces excessive wear on the bottom side of the belt.

The cord in a synchronous belt is made up of a number of small fiber strands twisted together. These strands can be twisted either clockwise or counterclockwise. The two twist directions are referred to as "S" twist and "Z" twist. To reduce lateral movement, most synchronous belts are constructed by alternately spiraling "S" and "Z" type cords. This specially constructed Carlisle belt for air cooled heat exchange applications uses only "Z" twist cords to predetermine the lateral movement of the belt.

Timken offers the following special construction "Z" twist synchronous belts for air-cooled heat exchange drives.

Part Number	Pitch Length (mm)	Top Width (mm)	Number of Teeth	Weight (lbs)
14M Pitch – High Torque Synchronous (HTS) Sprockets: MPB, QD, Taper Bushed (14mm)				
2800-14M-55F	2800	55	200	3.09
2800-14M-85F	2800	85	200	4.77
3150-14M-55F	3150	55	225	3.47
3150-14M-85F	3150	85	225	5.36
3360-14M-55F	3360	55	240	3.70
3360-14M-85F	3360	85	240	5.72
3500-14M-25F	3500	25	250	1.75
3500-14M-37F	3500	37	250	2.59
3500-14M-40F	3500	40	250	2.81
3500-14M-55F	3500	55	250	3.86
3500-14M-85F	3500	85	250	5.96
3850-14M-30F	3850	30	275	2.31
3850-14M-40F	3850	40	275	3.09
3850-14M-55F	3850	55	275	4.24
3850-14M-85F	3850	85	275	6.56
4326-14M-40F	4326	40	309	3.47
4326-14M-55F	4326	55	309	4.77
4326-14M-85F	4326	85	309	7.37

Note: Air Cool Heat Exchange belts can be cut to different widths as needed.

Air Cool Heat Exchange Synchronous Drive Sleeves

Part Number Example: **3150-14M-570SLF =**

3150 - **14M** - **570** **SL** **F**
Pitch Length (millimeters) Tooth Pitch (RPP tooth profile) Width (millimeters) Sleeve Z-Twist Cord Construction

- **Full factory width sleeves**
- **All sleeves will have the edges trimmed before shipment**
- **Cut sleeves cannot be accepted for return**
- **All weights are approximate**

Air Cool Heat Exchange Sleeve Part Numbers

Part Number	Top Width (mm)	Sleeve Weight (lbs)
14M Pitch – High Torque Synchronous (HTS) Sprockets: MPB, OD, Taper Bushed (14mm)		
2800-14M-570SLF	570	31.98
3150-14M-570SLF	570	35.98
3360-14M-570SLF	570	38.38
3500-14M-570SLF	570	39.97
3850-14M-570SLF	570	43.97
4326-14M-570SLF	570	49.41

Timken maintains inventory of most Carlisle® sleeve sizes. Non-stock sizes will be indicated by an asterisk following the part number. Contact customer service for availability. Minimum order quantity and/or extended lead times may apply.

Occasional production inconsistencies which may render a portion of the sleeve unusable can be present as a normal part of the production process.

Each sleeve is inspected to ensure that it contains 90% or more usable product. A full width sleeve with less than 10% unusable product is considered acceptable.



Cotton Drive® Timing Belts

Synchronous Drive Belt



Photo courtesy of Lummus Corporation

Cotton Drive® Timing Belts

Synchronous Drive Belt

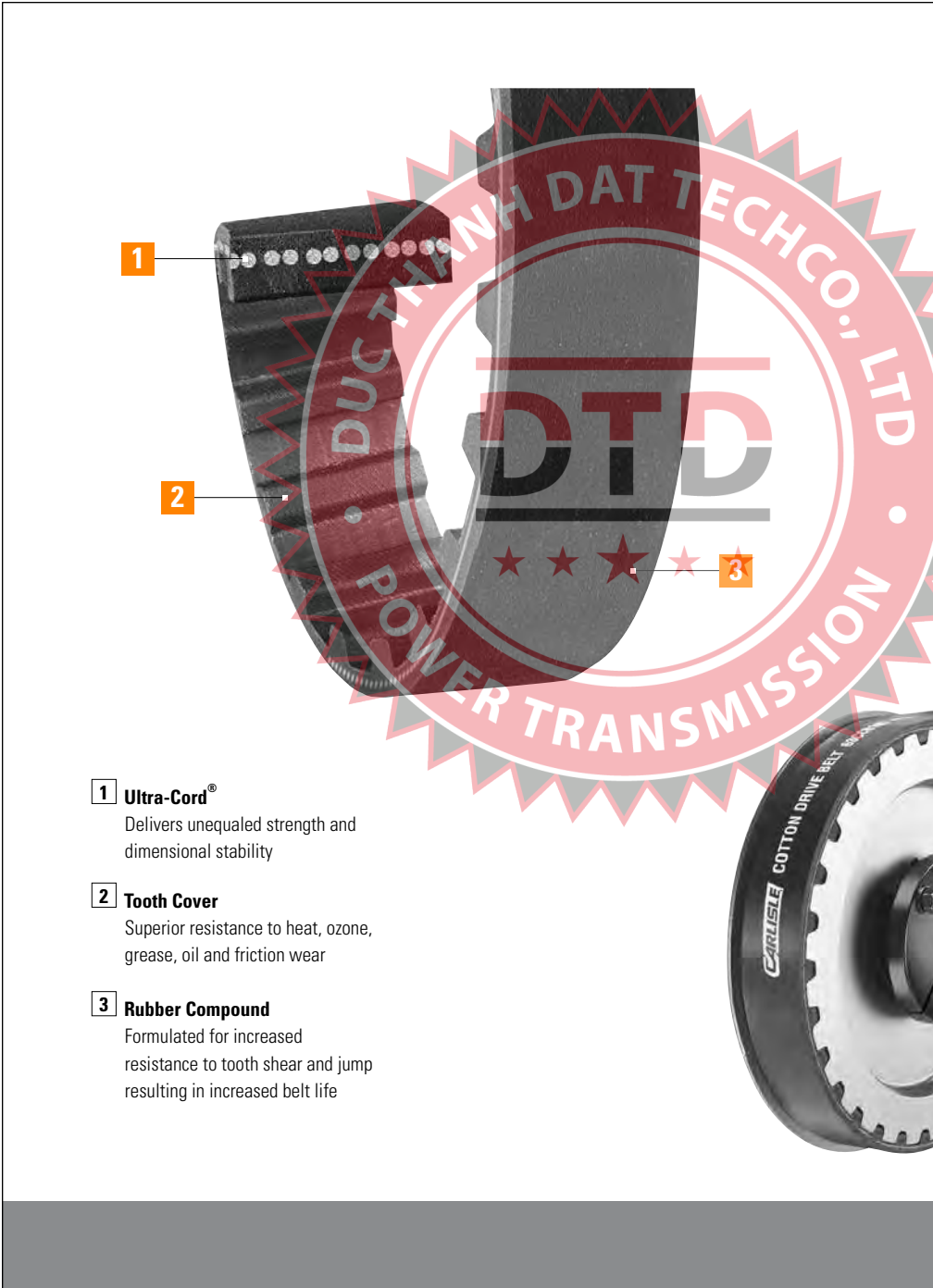

Ultra-Cord® tensile member

Custom designed for exact OEM replacement on cotton gin drives

Innovative engineering incorporates Ultra-Cord technology to provide the strength and length stability of steel cord, and offers improved life and performance over aramid fiber cords.

- 1 Ultra-Cord®**
Delivers unequalled strength and dimensional stability
- 2 Tooth Cover**
Superior resistance to heat, ozone, grease, oil and friction wear
- 3 Rubber Compound**
Formulated for increased resistance to tooth shear and jump resulting in increased belt life

Synchronous Belts

Cotton Drive® Timing Belts & Sprockets

Synchronous Drive System

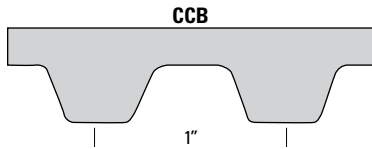

Part Number Example: **61CCB142** = **61** **CCB** **142**
 Pitch Length (inches) Cotton Cleaner Belt (1" tooth pitch) Drive Center Distance (inches)

Cotton Drive® belts are special 1" pitch timing belts designed for use on cotton gin machines. Uniquely constructed to handle this harsh, abrasive application.

Cotton Drive® Belt Part Numbers

Part Number	Pitch Length (in)	Top Width	Number of Teeth	Weight (lbs)
61CCB142	61.07	1.5	60	2.00
63CCB165	63.00	1.5	63	2.10
63CCB165-2-1/2*	63.00	2.5	63	3.50
64CCB170	63.95	1.5	64	2.20
65CCB175	64.95	1.5	65	2.30

*Non-stock item. Minimum order quantity and/or extended lead times may apply. Contact customer service for availability.

Cotton Drive® Sprocket Part Numbers

Part Number	Number Of Grooves	Face Diameter	Overall Diameter	Type	Bushing	E	F	K	L	Weight (lbs)	
21CCP	21	1.5	60	7-3/16	bushed	SK	1-1/16"	1-15/16"	5/8"	1-7/8"	11.5
30CCP	30	1.5	63	10	bushed	SK	1-1/16"	1-15/16"	5/8"	1-7/8"	16.5
32CCP	32	2.5	63	10-13/16	bushed	SK	1-1/16"	1-15/16"	5/8"	1-7/8"	18.5
38CCP	38	1.5	64	12-5/8	bushed	SK	1-1/16"	1-15/16"	5/8"	1-7/8"	23.5

Note: The 32-groove sprockets must be used with the 61CCB142 and are not interchangeable with other sprockets and belts.

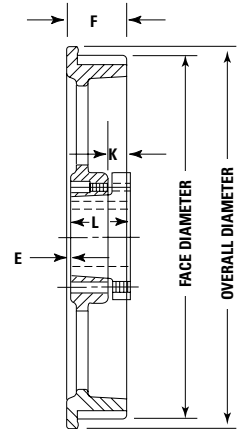

Cotton Drive® Timing Belts & Sprockets

Synchronous Drive System



Synchronous Belts

Gold-Ribbon® Cog-Belt®

V-Belt



Gold-Ribbon® Cog-Belt® V-Belt

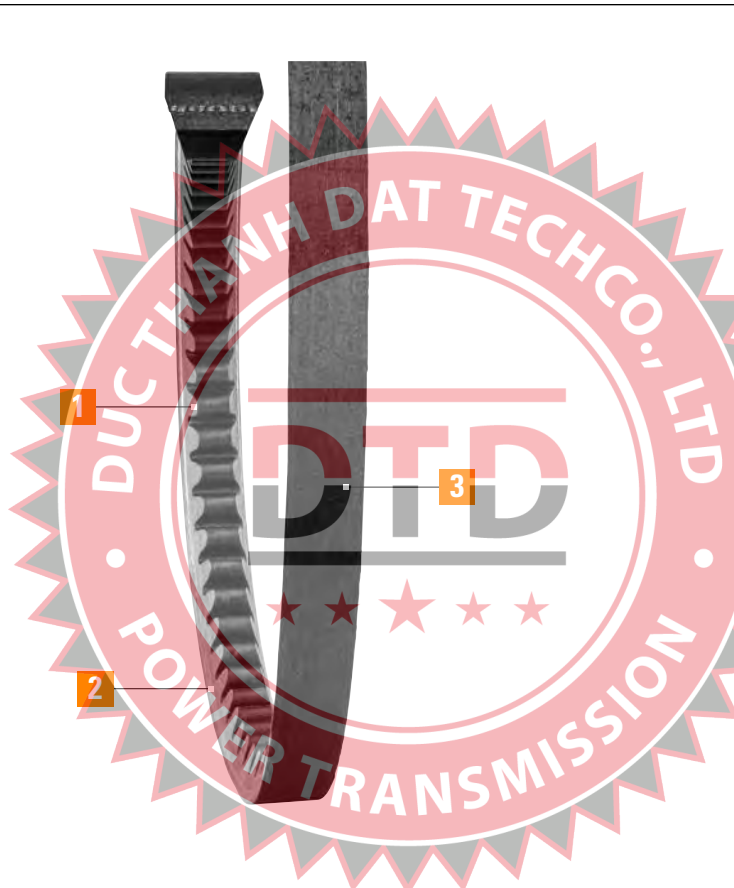

1 Unique Cog Design

permits flexibility that enables the belt to bend more easily around the pulley. It runs cooler – less heat equals longer belt life. Smaller pulley diameters mean lower cost and space savings.

2 Raw Edge Sidewalls

produce a higher coefficient of friction which keeps a tighter grip on the pulley and minimizes slippage. Improves performance and belt efficiency for unmatched economy of operation.

3 EPDM Construction

offers superior flex and load carrying capacity. It's durable as well as resistant to heat, hardening, and glazing. EPDM has excellent flexibility at high and low temperatures.

The energy saver

High performance
EPDM construction:

Broader temperature
operating range
(-50° – +250°)

50% longer life

30% higher
horsepower

Static conductive

Greater design flexibility

checkmate
matching

Applications:

Blowers
Pumps
HVAC
High ambient temperature
exhaust fans
& More

Recommended Sheaves:
Conventional – OD, Taper Bushed, or MST (A-B, C, D)

Heavy Duty V-Belts

Gold-Ribbon® Cog-Belt®

V-Belt

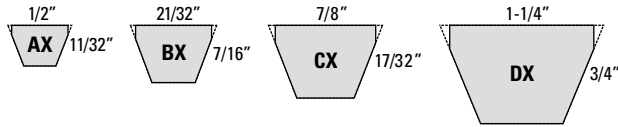

A new gold standard! Gold-Ribbon® sets the benchmark for classical v-belt performance – now made of EPDM (Ethylene Propylene Diene Monomer). Reduce downtime and save energy by selecting the right Gold-Ribbon® Cog-Belt® for your drive– the industry’s best just got better!

Unique Gold-Ribbon® Cog-Belt®

construction combines the superior flex capability of precision molded cogs with the tenacious gripping power of raw-edge sidewalls to provide significantly longer belt life, higher efficiency, and greater horsepower ratings than conventional wrapped belts.

Now made with EPDM, a synthetic rubber with outstanding properties, the Carlisle® Gold-Ribbon® Cog-Belt® is static conductive, more durable, and more resistant to heat, hardening, and glazing than ever before.

Ordinary wrapped belts waste energy, time, and money. The Gold-Ribbon Cog-Belt has been engineered to take advantage of countless developments in materials and technology. Today’s Gold-Ribbon Cog-Belt has earned industry wide respect and acceptance as the performance leader.

More reasons to switch to the Carlisle® Gold-Ribbon Cog-Belt:

- Specially formulated EPDM withstands extreme heat, dirt, grease, chemicals and environmental conditions.
- Design flexibility – Gold-Ribbon Cog-Belts transmit up to 30% more horse-power than conventional belts utilizing the same drive space – or pack the same horsepower into a space one-half to two-thirds the size.
- No excessive heat build-up or wear problems even under adverse operating conditions such as reverse bends, backside idlers and constant starts and stops.
- Save space with narrower pulleys, shorter centers and smaller pulley diameters.
- Reduced weight and overhang decreases bearing loads.

Performance and savings in one package.

The Gold-Ribbon Cog-Belt gets the job done anywhere there are space, weight or pulley limitations– or where increased horsepower capacity and/or higher speeds are necessary. Using smaller pulleys, the Gold-Ribbon Cog-Belt provides a higher horsepower rating than conventional wrapped v-belts on the market. This enables you to design more efficient, more compact, and ultimately more profitable drives.

Horsepower Rating Comparison

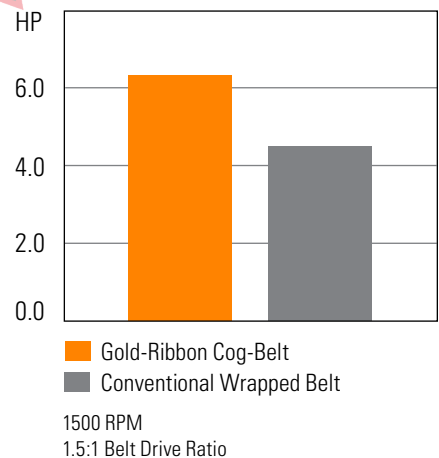

Gold-Ribbon® Cog-Belt®

V-Belt

Gold-Ribbon® Cog-Belt® Part Numbers

Part Number Example: **AX50** = **A** **X** **50**
↓ ↓ ↓
Cross Cogged Inside Circumference
Section Construction (inches)

Part Number	Outside Circumference	Weight (lbs)
AX Section – Recommended Sheaves: Conventional – OD, Taper Bushed, or MST (A-B)		
AX20	22.3	0.12
AX21	23.3	0.13
AX22	24.3	0.13
AX23	25.3	0.14
AX24	26.3	0.14
AX25	27.3	0.15
AX26	28.3	0.16
AX27	29.3	0.16
AX28	30.3	0.17
AX29	31.3	0.17
AX30	32.3	0.18
AX31	33.3	0.19
AX32	34.3	0.19
AX33	35.3	0.21
AX34	36.3	0.17
AX35	37.3	0.17
AX36	38.3	0.22
AX37	39.3	0.22
AX38	40.3	0.23
AX39	41.3	0.23
AX40	42.3	0.24
AX41	43.3	0.25
AX42	44.3	0.21
AX43	45.3	0.26
AX44	46.3	0.26
AX45	47.3	0.27
AX46	48.3	0.29
AX47	49.3	0.28
AX48	50.3	0.23
AX49	51.3	0.24
AX50	52.3	0.30
AX51	53.3	0.30
AX52	54.3	0.31

Part Number	Outside Circumference	Weight (lbs)
AX Section – Recommended Sheaves: Conventional – OD, Taper Bushed, or MST (A-B)		
AX53	55.3	0.32
AX54	56.3	0.32
AX55	57.3	0.33
AX56	58.3	0.33
AX57	59.3	0.34
AX58	60.3	0.36
AX59	61.3	0.35
AX60	62.3	0.29
AX61	63.3	0.36
AX62	64.3	0.37
AX63	65.3	0.38
AX64	66.3	0.38
AX65	67.3	0.39
AX66	68.3	0.32
AX67	69.3	0.40
AX68	70.3	0.33
AX69	71.3	0.41
AX70	72.3	0.42
AX71	73.3	0.42
AX72	74.3	0.35
AX73	75.3	0.43
AX74	76.3	0.44
AX75	77.3	0.36
AX76	78.3	0.45
AX77	79.3	0.46
AX78	80.3	0.46
AX79	81.3	0.46
AX80	82.3	0.47
AX81	83.3	0.39
AX82	84.3	0.39
AX83	85.3	0.40
AX84	86.3	0.40
AX85	87.3	0.49

Heavy Duty V-Belts

Gold-Ribbon® Cog-Belt®

V-Belt

Gold-Ribbon® Cog-Belt® Part Numbers

Part Number	Outside Circumference	Weight (lbs)
AX Section – Recommended Sheaves: Conventional – QD, Taper Bushed, or MST (A-B)		
AX86	88.3	0.50
AX87	89.3	0.42
AX88	90.3	0.51
AX89	91.3	0.42
AX90	92.3	0.42
AX91	93.3	0.52
AX92	94.3	0.43
AX93	95.3	0.45
AX94	96.3	0.44
AX95	97.3	0.45
AX96	98.3	0.55
AX97	99.3	0.56
AX98	100.3	0.47
AX99*	101.3	0.57
AX100	102.3	0.47
AX103	105.3	0.59
AX105	107.3	0.60
AX110	112.3	0.63
AX112	114.3	0.64
AX120	122.3	0.56
AX128	130.3	0.60
AX136	138.3	0.63
AX144	146.3	0.67
AX158*	160.3	0.74
AX173*	175.3	0.80
AX180*	182.3	0.84
BX Section – Recommended Sheaves: Conventional – QD, Taper Bushed, or MST (A-B)		
BX23	26.3	0.20
BX26	29.3	0.25
BX27	30.3	0.26
BX28	31.3	0.27
BX29	32.3	0.25

Part Number	Outside Circumference	Weight (lbs)
BX Section – Recommended Sheaves: Conventional – QD, Taper Bushed, or MST (A-B)		
BX30	33.3	0.31
BX31	34.3	0.32
BX32	35.3	0.27
BX33	36.3	0.34
BX34	37.3	0.29
BX35	38.3	0.34
BX36	39.3	0.35
BX37	40.3	0.36
BX38	41.3	0.37
BX39	42.3	0.33
BX40	43.3	0.39
BX41	44.3	0.34
BX42	45.3	0.40
BX43	46.3	0.41
BX44	47.3	0.42
BX45	48.3	0.43
BX46	49.3	0.44
BX47	50.3	0.45
BX48	51.3	0.46
BX49	52.3	0.47
BX50	53.3	0.48
BX51	54.3	0.49
BX52	55.3	0.50
BX53	56.3	0.53
BX54	57.3	0.52
BX55	58.3	0.53
BX56	59.3	0.54
BX57	60.3	0.57
BX58	61.3	0.47
BX59	62.3	0.56
BX60	63.3	0.49
BX61	64.3	0.58
BX62	65.3	0.59

Gold-Ribbon® Cog-Belt® V-Belt

Part Number Example: **BX70** = **B** **X** **70**
↓ ↓ ↓
Cross Cogged Inside Circumference
Section Construction (inches)

Part Number	Outside Circumference	Weight (lbs)
BX Section – Recommended Sheaves: Conventional – OD, Taper Bushed, or MST (A-B)		
BX63	66.3	0.60
BX64	67.3	0.61
BX65	68.3	0.62
BX66	69.3	0.53
BX67	70.3	0.64
BX68	71.3	0.55
BX69	72.3	0.66
BX70	73.3	0.67
BX71	74.3	0.57
BX72	75.3	0.68
BX73	76.3	0.70
BX74	77.3	0.71
BX75	78.3	0.60
BX76	79.3	0.72
BX77	80.3	0.73
BX78	81.3	0.73
BX79	82.3	0.74
BX80	83.3	0.75
BX81	84.3	0.65
BX82	85.3	0.66
BX83	86.3	0.67
BX84	87.3	0.82
BX85	88.3	0.68
BX86	89.3	0.81
BX87	90.3	0.70
BX88	91.3	0.83
BX89	92.3	0.71
BX90	93.3	0.72
BX91	94.3	0.73
BX92	95.3	0.90
BX93	96.3	0.87
BX94	97.3	0.88
BX95	98.3	0.89

Part Number	Outside Circumference	Weight (lbs)
BX Section – Recommended Sheaves: Conventional – OD, Taper Bushed, or MST (A-B)		
BX96	99.3	0.77
BX97	100.3	0.77
BX98	101.3	0.78
BX99	102.3	0.93
BX100	103.3	0.94
BX103	106.3	0.82
BX105	108.3	0.99
BX106	109.3	0.85
BX108	111.3	0.86
BX112	115.3	0.89
BX113	116.3	1.06
BX115	118.3	0.92
BX116	119.3	1.09
BX120	123.3	0.95
BX123	126.3	0.98
BX124	127.3	0.98
BX126	129.3	1.00
BX128	131.3	1.02
BX130	133.3	1.03
BX133	136.3	1.05
BX136	139.3	1.08
BX140	143.3	1.11
BX144	147.3	1.14
BX148	151.3	1.17
BX150	153.3	1.19
BX151*	154.3	1.19
BX154	157.3	1.22
BX158	161.3	1.25
BX162	165.3	1.28
BX173	176.3	1.36
BX180	183.3	1.42
BX191	194.3	1.50
BX195	198.3	1.53

Heavy Duty V-Belts

Gold-Ribbon® Cog-Belt®

V-Belt

Gold-Ribbon® Cog-Belt® Part Numbers

Part Number	Outside Circumference	Weight (lbs)
BX Section – Recommended Sheaves: Conventional – QD, Taper Bushed, or MST (A-B)		
BX205*	208.3	1.80
BX210	213.3	2.15
BX225	227.4	2.35
BX240	242.4	2.50
BX255*	257.4	3.10
BX270*	272.4	3.05
BX300*	302.4	3.05
CX Section – Recommended Sheaves: Conventional – QD, Taper Bushed, or MST (C)		
CX51	55.4	0.77
CX52*	56.4	0.77
CX55	59.4	0.83
CX60	64.4	0.90
CX66	70.4	0.96
CX68	72.4	1.01
CX72	76.4	1.06
CX75	79.4	1.10
CX78	82.4	1.15
CX81	85.4	1.19
CX85	89.4	1.24
CX90	94.4	1.31
CX96	100.4	1.39
CX98*	102.4	1.39
CX100	104.4	1.45
CX101	105.4	1.46
CX103	107.4	1.46
CX105	109.4	1.52
CX106*	110.4	1.50
CX109	113.4	1.57
CX111	115.4	1.60
CX112	116.4	1.62
CX115	119.4	1.66
CX120	124.4	1.73

Part Number	Outside Circumference	Weight (lbs)
CX Section – Recommended Sheaves: Conventional – QD, Taper Bushed, or MST (C)		
CX124	128.4	1.78
CX128	132.4	1.84
CX133	137.4	1.86
CX136	140.4	1.95
CX144	148.4	2.06
CX148	152.4	2.11
CX150	154.4	2.14
CX158	162.4	2.25
CX162	166.4	2.31
CX173	177.4	2.46
CX180	184.4	2.55
CX190	194.4	2.63
CX195	199.4	2.76
CX210	214.4	3.25
CX225	228.1	3.75
CX240	243.1	4.10
CX255	258.1	4.45
CX270	273.1	3.85
CX300	303.1	4.95
CX330*	333.1	5.35
DX Section – Recommended Sheaves: Conventional – QD, Taper Bushed, or MST (D)		
DX71*	76.5	2.15
DX120	125.5	4.26
DX128*	133.5	3.75
DX144*	149.5	4.19
DX158*	163.5	4.58
DX162*	167.5	4.69
DX173*	178.5	5.00
DX180*	185.5	5.20
DX195*	200.5	5.61
DX210*	215.5	7.20
DX225*	228.6	7.70

Gold-Ribbon® Cog-Belt® V-Belt

Part Number Example: **DX270** = **D** **X** **270**
Cross Section Cogged Construction Inside Circumference (inches)

Part Number	Outside Circumference	Weight (lbs)
DX Section – Recommended Sheaves: Conventional – OD, Taper Bushed, or MST (D)		
DX240	243.6	8.15
DX255*	258.6	7.50
DX270	273.6	9.00
DX300*	303.6	9.50
DX330*	333.6	10.90

*Non-stock item. Minimum order quantity and/or extended lead times may apply. Contact customer service for availability.

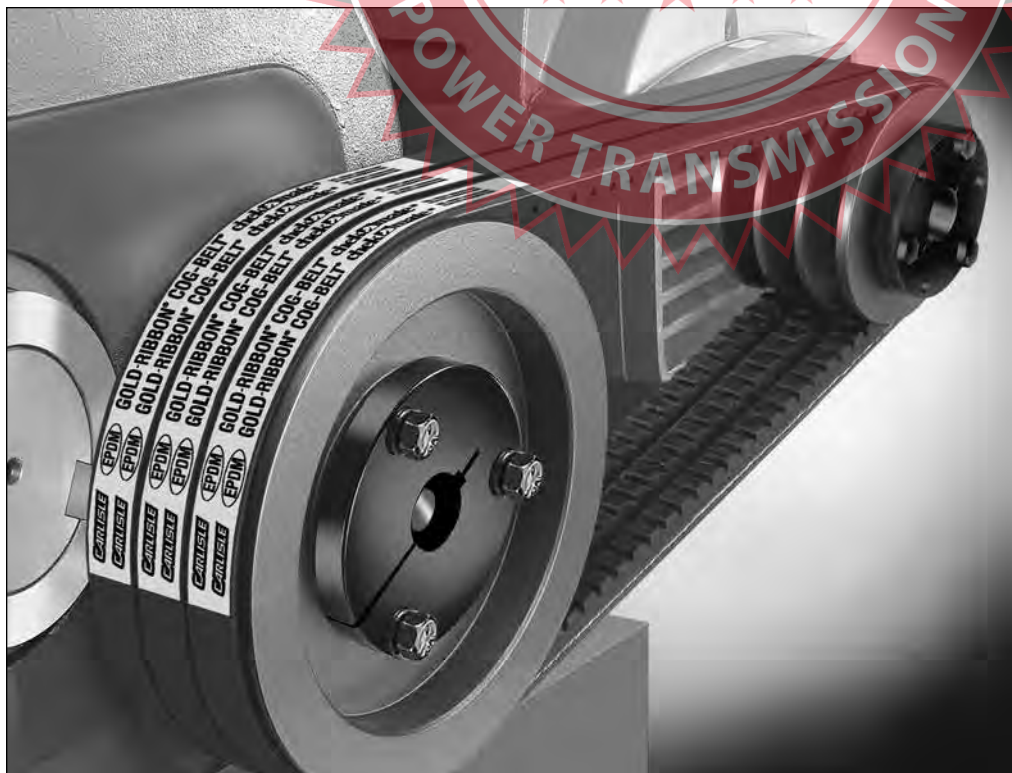
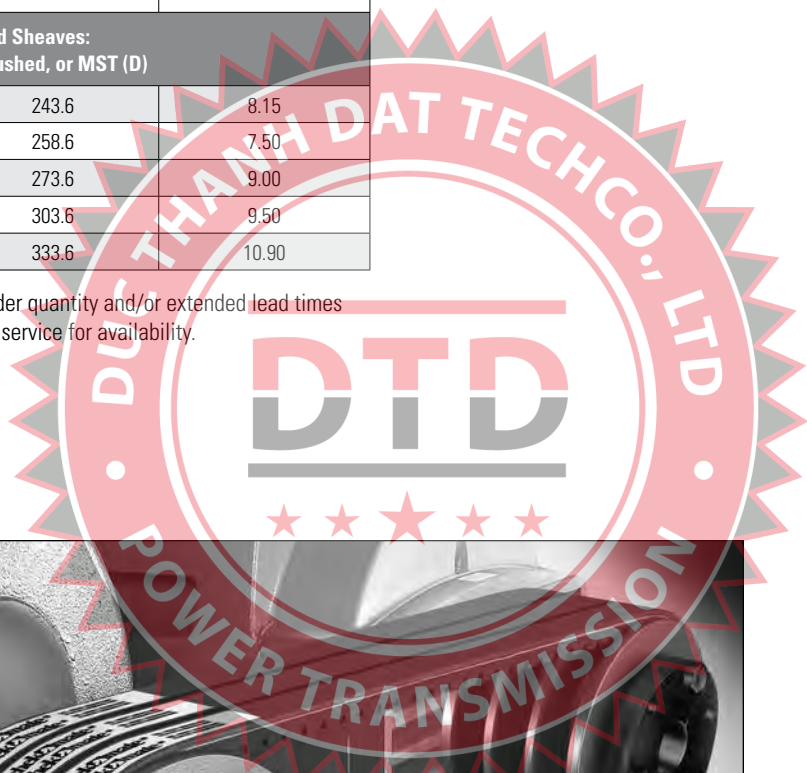

Heavy Duty V-Belts

Super II[®]

V-Belt



Super II[®] V-Belt

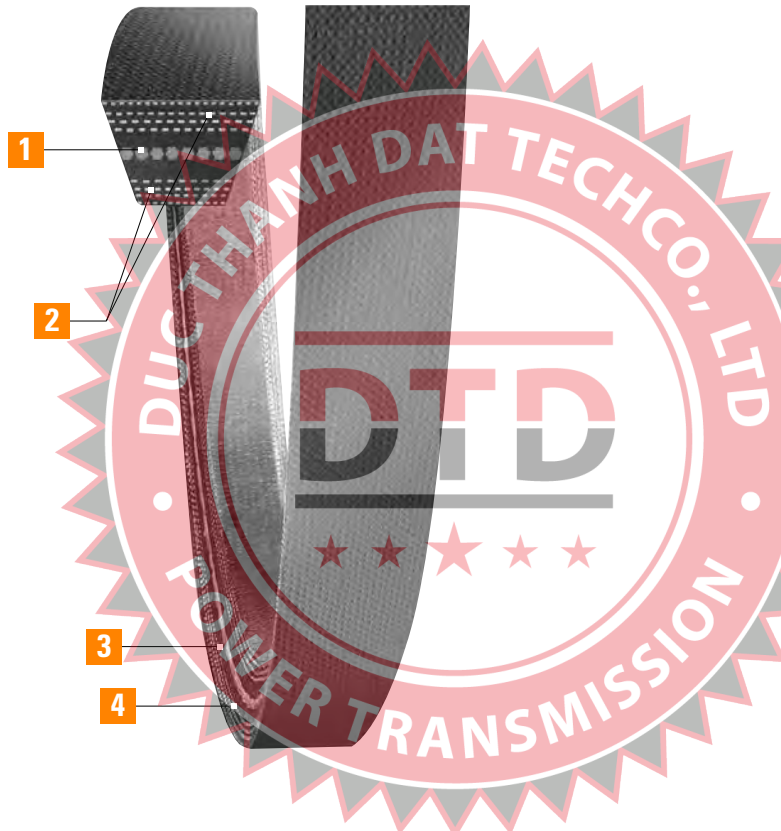

1 High-modulus polyester cord located in the belt mid-section is specially treated to withstand extreme belt loads and shock without stretching. The central position contributes to greater strength, balance and longer life.

2 Multiple fabric plies, top and bottom, relieve stress on the load-carrying center cord for added flexibility. Quantity of fabric plies varies per cross section, with equal number of plies above and below center cord: A=3 plies, B=4 plies, C=5 plies.

3 Unique Raw Edge belt sidewalls grip pulleys better to minimize belt slip, noise and drive vibration.

4 Specially formulated rubber compound supports cord more evenly, top and bottom to dissipate heat more readily, and provide better oil, heat and ozone resistance.

Recommended Sheaves:
Conventional – OD, Taper Bushed, or MST (A-B, C)

The “Problem Solver”

Blows the cover off conventional wrapped belts

For classical applications

chekmate[®]
Matching

Applications:
Shaker screens
Debarkers
HVAC
Industrial washers
and dryers
& More

Heavy Duty V-Belts

Super II[®] V-Belt

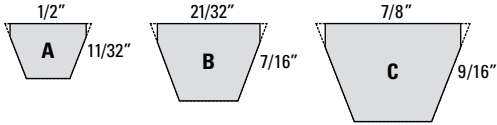

The Problem Solver! The solution to the constant and costly problem of replacing or re-tensioning ordinary v-belts on troublesome drives.

Look what the Super II[®] v-belt has to offer:

- Greater strength
- Longer life
- Better heat dissipation
- Better grip for controlled slippage
- Greater flexibility

Timken has designed this belt for the toughest, heavy-duty industrial applications – the kind that devour ordinary wrapped belts. The Super II[®] puts an end to the constant, costly problem of replacing or re-tensioning belts. Our secret: Super II v-belt's unique construction.

Don't take our word for it! Compare Super II to the belt you are now using on your heavy torque, high horsepower and extreme shock-load applications.

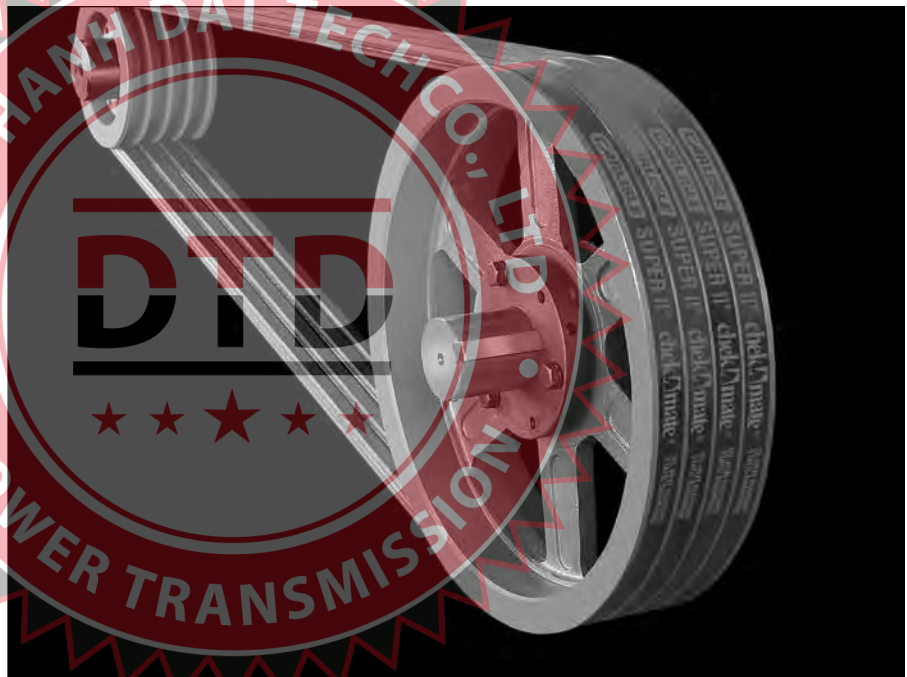

Tensile Strength

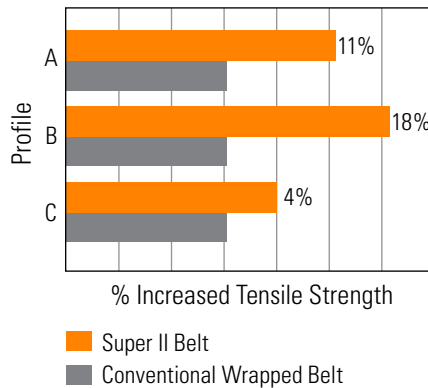

Accelerated Life Test (Laboratory)

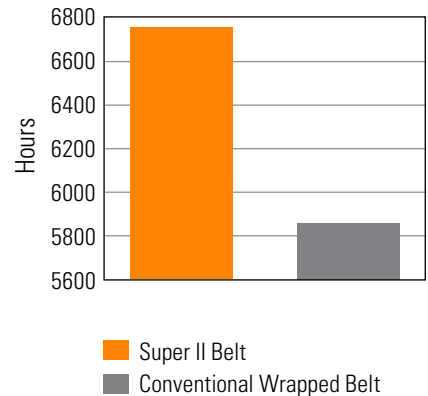

Super II[®] V-Belt Part Numbers

Part Number Example: **A50** = **A** **50**
↓ Cross Section ↓ Inside Circumference (inches)

Part Number	Outside Circumference	Weight (lbs)
A Section – Recommended Sheaves: Conventional – QD, Taper Bushed, or MST (A-B)		
A21	23.2	0.15
A22	24.2	0.16
A23	25.2	0.17
A24	26.2	0.17
A25	27.2	0.18
A26	28.2	0.19
A27	29.2	0.19
A28	30.2	0.20
A29	31.2	0.20
A30	32.2	0.21
A31	33.2	0.22
A32	34.2	0.23
A33	35.2	0.23
A34	36.2	0.24
A35	37.2	0.25
A36	38.2	0.25
A37	39.2	0.26
A38	40.2	0.27
A39	41.2	0.27
A40	42.2	0.28
A41	43.2	0.29
A42	44.2	0.29
A43	45.2	0.30
A44	46.2	0.31
A45	47.2	0.31
A46	48.2	0.32
A47	49.2	0.33
A48	50.2	0.33
A49	51.2	0.34
A50	52.2	0.35
A51	53.2	0.35
A52	54.2	0.36
A53	55.2	0.37

Part Number	Outside Circumference	Weight (lbs)
A Section – Recommended Sheaves: Conventional – QD, Taper Bushed, or MST (A-B)		
A54	56.2	0.38
A55	57.2	0.38
A56	58.2	0.39
A57	59.2	0.39
A58	60.2	0.40
A59	61.2	0.41
A60	62.2	0.42
A61	63.2	0.42
A62	64.2	0.43
A63	65.2	0.44
A64	66.2	0.44
A65	67.2	0.45
A66	68.2	0.46
A67	69.2	0.46
A68	70.2	0.46
A69	71.2	0.47
A70	72.2	0.48
A71	73.2	0.48
A72	74.2	0.49
A73	75.2	0.50
A74	76.2	0.51
A75	77.2	0.51
A76	78.2	0.52
A77	79.2	0.53
A78	80.2	0.53
A79	81.2	0.54
A80	82.2	0.55
A81	83.2	0.55
A82	84.2	0.56
A83	85.2	0.57
A84	86.2	0.57
A85	87.2	0.58
A86	88.2	0.59

Heavy Duty V-Belts

Super II® V-Belt

Super II® V-Belt Part Numbers

Part Number	Outside Circumference	Weight (lbs)
A Section – Recommended Sheaves: Conventional – QD, Taper Bushed, or MST (A-B)		
A87	89.2	0.59
A88	90.2	0.60
A89	91.2	0.61
A90	92.2	0.61
A91	93.2	0.62
A92	94.2	0.63
A93	95.2	0.63
A94	96.2	0.64
A95	97.2	0.65
A96	98.2	0.65
A97	99.2	0.66
A98	100.2	0.67
A100	102.2	0.68
A103	105.2	0.70
A105	107.2	0.71
A110	112.2	0.75
A112	114.2	0.76
A120	122.2	0.81
A128	130.2	0.87
A136	138.2	0.93
A144	146.2	0.98
A158	160.2	1.08
A173*	175.2	1.18
A180*	182.2	1.23
B Section – Recommended Sheaves: Conventional – QD, Taper Bushed, or MST (A-B)		
B24	27.1	0.29
B26	29.1	0.30
B27	30.1	0.31
B28	31.1	0.32
B29	32.1	0.33
B30	33.1	0.34
B31	34.1	0.35

Part Number	Outside Circumference	Weight (lbs)
B Section – Recommended Sheaves: Conventional – QD, Taper Bushed, or MST (A-B)		
B32	35.1	0.37
B33	36.1	0.37
B34	37.1	0.39
B35	38.1	0.40
B36	39.1	0.41
B37	40.1	0.42
B38	41.1	0.43
B39	42.1	0.44
B40	43.1	0.45
B41	44.1	0.46
B42	45.1	0.48
B43	46.1	0.48
B44	47.1	0.49
B45	48.1	0.50
B46	49.1	0.52
B47	50.1	0.53
B48	51.1	0.54
B49	52.1	0.55
B50	53.1	0.56
B51	54.1	0.57
B52	55.1	0.58
B53	56.1	0.59
B54	57.1	0.60
B55	58.1	0.61
B56	59.1	0.62
B57	60.1	0.63
B58	61.1	0.65
B59	62.1	0.66
B60	63.1	0.67
B61	64.1	0.68
B62	65.1	0.69
B63	66.1	0.70
B64	67.1	0.71

Super II[®] V-Belt

Part Number Example: **B70** = **B** **70**
↓ Cross Section ↓ Inside Circumference (inches)

Part Number	Outside Circumference	Weight (lbs)
B Section – Recommended Sheaves: Conventional – OD, Taper Bushed, or MST (A-B)		
B65	68.1	0.72
B66	69.1	0.73
B67	70.1	0.74
B68	71.1	0.75
B69	72.1	0.77
B70	73.1	0.78
B71	74.1	0.79
B72	75.1	0.80
B73	76.1	0.81
B74	77.1	0.82
B75	78.1	0.83
B76	79.1	0.84
B77	80.1	0.85
B78	81.1	0.86
B79	82.1	0.87
B80	83.1	0.88
B81	84.1	0.90
B82	85.1	0.90
B83	86.1	0.92
B84	87.1	0.93
B85	88.1	0.94
B86	89.1	0.95
B87	90.1	0.96
B88	91.1	0.97
B89	92.1	0.98
B90	93.1	0.99
B91	94.1	1.00
B92	95.1	1.01
B93	96.1	1.03
B94	97.1	1.04
B95	98.1	1.05
B96	99.1	1.06
B97	100.1	1.07

Part Number	Outside Circumference	Weight (lbs)
B Section – Recommended Sheaves: Conventional – OD, Taper Bushed, or MST (A-B)		
B98	101.1	1.08
B99	102.1	1.09
B100	103.1	1.10
B101	104.1	1.11
B103	106.1	1.13
B105	108.1	1.15
B106	109.1	1.17
B108	111.1	1.19
B112	115.1	1.23
B115	118.1	1.26
B116	119.1	1.27
B118	121.1	1.30
B120	123.1	1.27
B123	126.1	1.35
B124	127.1	1.36
B126	129.1	1.38
B128	131.1	1.41
B130	133.1	1.43
B133	136.1	1.46
B136	139.1	1.49
B140	143.1	1.54
B142	145.1	1.56
B143*	146.1	1.57
B144	147.1	1.58
B148	151.1	1.62
B150	153.1	1.64
B154	157.1	1.69
B156	159.1	1.71
B158	161.1	1.73
B162	165.1	1.77
B173	176.1	1.89
B180	183.1	1.97
B188	191.1	2.05

Heavy Duty V-Belts

Super II[®] V-Belt

Super II[®] V-Belt Part Numbers

Part Number Example: **C100** = **C** **100**
↑ ↑
Cross Inside Circumference
Section (inches)

Part Number	Outside Circumference	Weight (lbs)
B Section – Recommended Sheaves: Conventional – QD, Taper Bushed, or MST (A-B)		
B191	194.1	2.09
B195	198.1	2.13
C Section – Recommended Sheaves: Conventional – QD, Taper Bushed, or MST (C)		
C51	55.2	1.08
C55	59.2	1.16
C59	63.2	1.23
C60	64.2	1.25
C68	72.2	1.37
C72	76.2	1.46
C75	79.2	1.51
C78	82.2	1.57
C81	85.2	1.63
C85	89.2	1.75
C90	94.2	1.85
C96	100.2	1.97
C97*	101.2	1.99
C100	104.2	2.05
C101	105.2	2.07
C105	109.2	2.15
C109	113.2	2.23
C111	115.2	2.27
C112	116.2	2.29
C115	119.2	2.35
C120	124.2	2.45
C124	128.2	2.53
C128	132.2	2.61
C136	140.2	2.77
C144	148.2	2.93
C148	152.2	3.01
C150	154.2	3.05
C152*	156.2	3.09
C158	162.2	3.21

Part Number	Outside Circumference	Weight (lbs)
C Section – Recommended Sheaves: Conventional – QD, Taper Bushed, or MST (C)		
C160*	164.2	3.25
C162	166.2	3.29
C173	177.2	3.51
C180	184.2	3.65
C195	199.2	3.95

*Non-stock item. Minimum order quantity and/or extended lead times may apply. Contact customer service for availability.

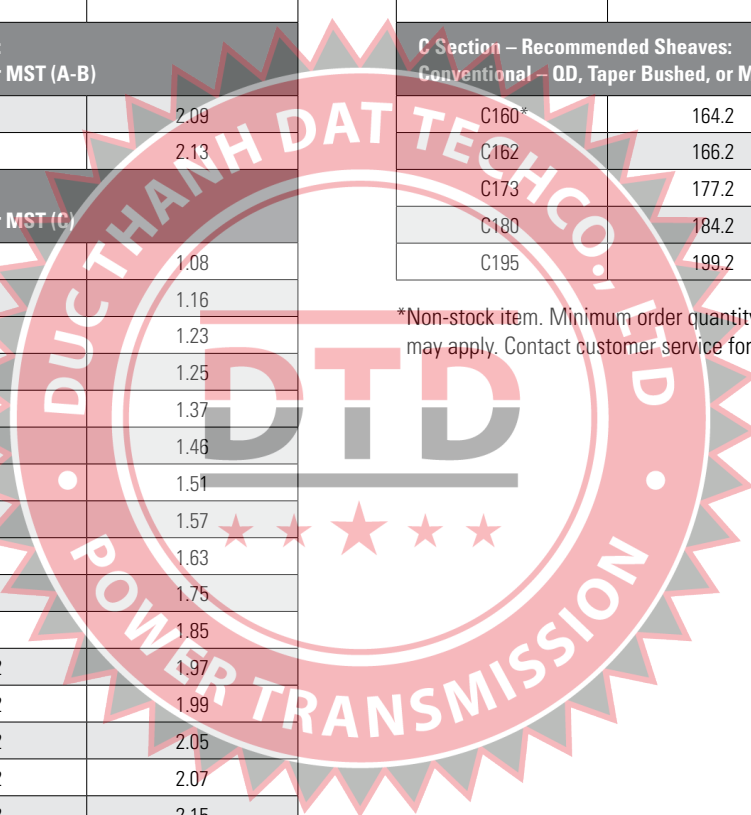

Super Blue Ribbon® V-Belt

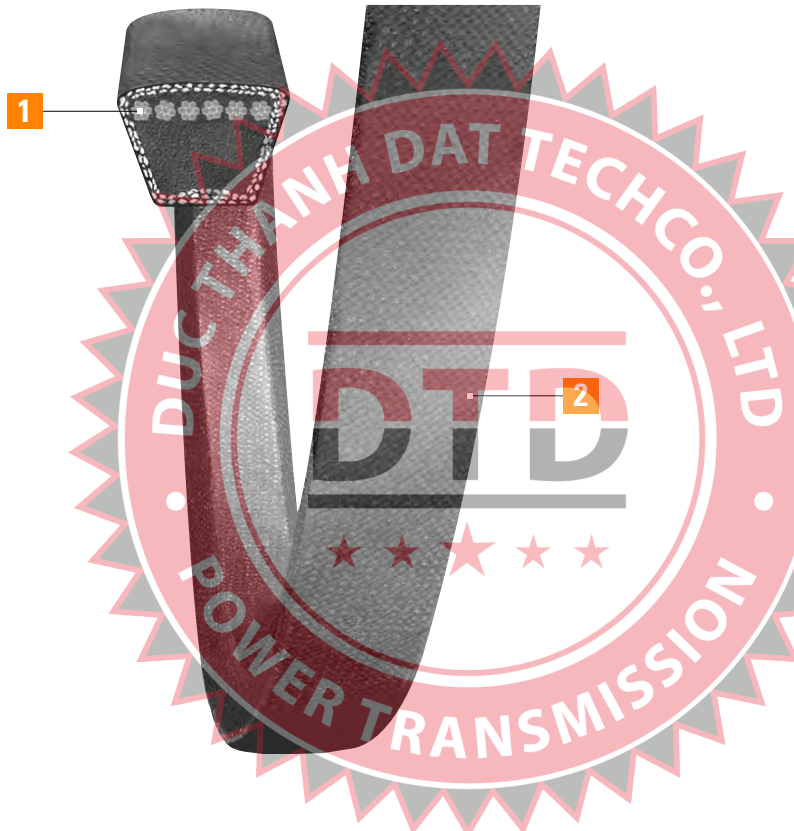

The finest wrapped belt
in the industry

Super rated at
standard prices

Longer life

checkmate®
matching

Applications:

- Mixers
- Pumps
- Conveyors
- HVAC
- Anything and
everything
& More

1 Cord

The cord is coated with a special compound that produces a secure, long-lasting bond with the surrounding rubber to assure longer life without separation problems. In addition, Blue Ribbon's dependable length stability means the belt requires significantly less re-tensioning and take-up.

2 Cover

The heavy-duty fabric cover not only protects the core; but its extra flexibility permits the belt to bend more easily around the smallest pulleys with far less strain on the fabric. It's a smoother running belt. Longer belt life results in less frequent replacement, less downtime and lower maintenance costs.

PLUS!

The Timken Ironclad Guarantee assures worry-free belt performance!

Recommended Sheaves:
Conventional – OD, Taper Bushed, or MST (A-B, C, D)

Heavy Duty V-Belts

Super Blue Ribbon®

V-Belt

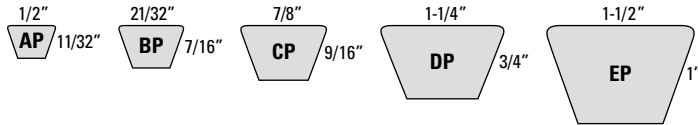

The finest wrapped belt in the industry and workhorse of classical v-belts.

Heavy-Duty Cover – Stress-relieved fabric cover flexes better than ordinary fabric to improve belt life, and assures a smooth transfer of power.

Super Blue's resistance to oil, heat, weather and aggressive environmental conditions is outstanding.

Super Blue Ribbon® v-belts operate within a wide range of load capacities and speeds – with rated performance from 100 to 8,000 RPM and horsepower capability from 1 to 1,100 horsepower.

Super Blue Ribbon is the ideal choice for dependable performance on an extremely wide range of applications – A, B, C, D, and E sections – single or multiple drive.



Super Blue Ribbon®

V-Belt

Super Blue Ribbon® Part Numbers

Part Number Example: **AP50** = **A** **P** **50**
↓ ↓ ↓
Cross Section Wrapped Molded Inside Circumference
Construction (inches)

Part Number	Outside Circumference	Weight (lbs)
A Section – Recommended Sheaves: Conventional – QD, Taper Bushed, or MST (A-B)		
AP20	22.3	0.11
AP21	23.3	0.14
AP22	24.3	0.15
AP23	25.3	0.15
AP24	26.3	0.16
AP25	27.3	0.17
AP26	28.3	0.17
AP27	29.3	0.18
AP28	30.3	0.19
AP29	31.3	0.19
AP30	32.3	0.20
AP31	33.3	0.21
AP32	34.3	0.21
AP33	35.3	0.22
AP34	36.3	0.22
AP35	37.3	0.23
AP36	38.3	0.24
AP37	39.3	0.24
AP38	40.3	0.25
AP39	41.3	0.26
AP40	42.3	0.26
AP41	43.3	0.27
AP42	44.3	0.27
AP43	45.3	0.28
AP44	46.3	0.29
AP45	47.3	0.29
AP46	48.3	0.30
AP47	49.3	0.31
AP48	50.3	0.31
AP49	51.3	0.32
AP50	52.3	0.32
AP51	53.3	0.33
AP52	54.3	0.34

Part Number	Outside Circumference	Weight (lbs)
A Section – Recommended Sheaves: Conventional – QD, Taper Bushed, or MST (A-B)		
AP53	55.3	0.34
AP54	56.3	0.35
AP55	57.3	0.36
AP56	58.3	0.36
AP57	59.3	0.37
AP58	60.3	0.37
AP59	61.3	0.38
AP60	62.3	0.39
AP61	63.3	0.39
AP62	64.3	0.40
AP63	65.3	0.41
AP64	66.3	0.41
AP65	67.3	0.41
AP66	68.3	0.43
AP67	69.3	0.43
AP68	70.3	0.44
AP69	71.3	0.44
AP70	72.3	0.45
AP71	73.3	0.46
AP72	74.3	0.46
AP73	75.3	0.46
AP74	76.3	0.47
AP75	77.3	0.48
AP76	78.3	0.48
AP77	79.3	0.49
AP78	80.3	0.49
AP79	81.3	0.50
AP80	82.3	0.51
AP81	83.3	0.51
AP82	84.3	0.52
AP83	85.3	0.52
AP84	86.3	0.53
AP85	87.3	0.54

Heavy Duty V-Belts

Super Blue Ribbon®

V-Belt

Super Blue Ribbon® Part Numbers

Part Number	Outside Circumference	Weight (lbs)
A Section – Recommended Sheaves: Conventional – QD, Taper Bushed, or MST (A-B)		
AP86	88.3	0.55
AP87	89.3	0.55
AP88	90.3	0.56
AP89	91.3	0.56
AP90	92.3	0.58
AP91	93.3	0.57
AP92	94.3	0.58
AP93	95.3	0.60
AP94	96.3	0.60
AP95	97.3	0.60
AP96	98.3	0.61
AP97	99.3	0.61
AP98	100.3	0.62
AP99	101.3	0.62
AP100	102.3	0.64
AP101	103.3	0.64
AP102	104.3	0.64
AP103	105.3	0.65
AP104	106.3	0.66
AP105	107.3	0.66
AP108	110.3	0.70
AP110	112.3	0.69
AP112	114.3	0.70
AP114	116.3	0.74
AP115	117.3	0.74
AP116	118.3	0.75
AP118	120.3	0.76
AP120	122.3	0.75
AP124	126.3	0.78
AP125	127.3	0.78
AP126	128.3	0.79
AP127	129.3	0.80
AP128	130.3	0.80

Part Number	Outside Circumference	Weight (lbs)
A Section – Recommended Sheaves: Conventional – QD, Taper Bushed, or MST (A-B)		
AP130	132.3	0.82
AP133	135.3	0.84
AP134	136.3	0.84
AP136	138.3	0.85
AP140	142.3	0.88
AP141	143.3	0.88
AP144	146.3	0.90
AP148	150.3	0.95
AP158	160.3	1.01
AP162*	164.3	1.04
AP173	175.3	1.11
AP180	182.3	1.15
AP220*	222.3	1.38
B Section – Recommended Sheaves: Conventional – QD, Taper Bushed, or MST (A-B)		
BP23	26.3	0.20
BP24	27.3	0.21
BP25	28.3	0.22
BP26	29.3	0.23
BP27	30.3	0.24
BP28	31.3	0.31
BP29	32.3	0.25
BP30	33.3	0.33
BP31	34.3	0.27
BP32	35.3	0.35
BP33	36.3	0.36
BP34	37.3	0.37
BP35	38.3	0.38
BP36	39.3	0.39
BP37	40.3	0.41
BP38	41.3	0.42
BP39	42.3	0.43
BP40	43.3	0.44

Super Blue Ribbon®

V-Belt

Part Number Example: **BP50** = **B** **P** **50**
↓ ↓ ↓
Cross Wrapped Molded Inside Circumference
Section Construction (inches)

Part Number	Outside Circumference	Weight (lbs)
B Section – Recommended Sheaves: Conventional – QD, Taper Bushed, or MST (A-B)		
BP41	44.3	0.44
BP42	45.3	0.45
BP43	46.3	0.47
BP44	47.3	0.48
BP45	48.3	0.49
BP46	49.3	0.50
BP47	50.3	0.51
BP48	51.3	0.52
BP49	52.3	0.53
BP50	53.3	0.54
BP51	54.3	0.55
BP52	55.3	0.56
BP53	56.3	0.57
BP54	57.3	0.58
BP55	58.3	0.59
BP56	59.3	0.60
BP57	60.3	0.61
BP58	61.3	0.62
BP59	62.3	0.63
BP60	63.3	0.64
BP61	64.3	0.65
BP62	65.3	0.66
BP63	66.3	0.67
BP64	67.3	0.68
BP65	68.3	0.69
BP66	69.3	0.70
BP67	70.3	0.71
BP68	71.3	0.72
BP69	72.3	0.74
BP70	73.3	0.74
BP71	74.3	0.75
BP72	75.3	0.77
BP73	76.3	0.78

Part Number	Outside Circumference	Weight (lbs)
B Section – Recommended Sheaves: Conventional – QD, Taper Bushed, or MST (A-B)		
BP74	77.3	0.79
BP75	78.3	0.80
BP76	79.3	0.81
BP77	80.3	0.82
BP78	81.3	0.83
BP79	82.3	0.84
BP80	83.3	0.85
BP81	84.3	0.86
BP82	85.3	0.87
BP83	86.3	0.88
BP84	87.3	0.89
BP85	88.3	0.90
BP86	89.3	0.91
BP87	90.3	0.92
BP88	91.3	0.93
BP89	92.3	0.92
BP90	93.3	0.95
BP91	94.3	0.94
BP92	95.3	0.97
BP93	96.3	0.98
BP94	97.3	0.97
BP95	98.3	1.00
BP96	99.3	1.01
BP97	100.3	1.02
BP98	101.3	1.01
BP99	102.3	1.02
BP100	103.3	1.06
BP101	104.3	1.04
BP102	105.3	1.05
BP103	106.3	1.09
BP104	107.3	1.07
BP105	108.3	1.11
BP106	109.3	1.09

Heavy Duty V-Belts

Super Blue Ribbon®

V-Belt

Super Blue Ribbon® Part Numbers

Part Number	Outside Circumference	Weight (lbs)
B Section – Recommended Sheaves: Conventional – QD, Taper Bushed, or MST (A-B)		
BP107	110.3	1.10
BP108	111.3	1.14
BP109	112.3	1.12
BP110	113.3	1.13
BP111	114.3	1.14
BP112	115.3	1.18
BP113	116.3	1.16
BP114	117.3	1.17
BP115	118.3	1.18
BP116	119.3	1.22
BP117	120.3	1.20
BP118	121.3	1.21
BP119	122.3	1.22
BP120	123.3	1.26
BP122	125.3	1.24
BP123	126.3	1.25
BP124	127.3	1.27
BP125	128.3	1.27
BP126	129.3	1.29
BP128	131.3	1.31
BP130	133.3	1.33
BP131	134.3	1.33
BP132	135.3	1.35
BP133	136.3	1.36
BP134	137.3	1.37
BP135	138.3	1.38
BP136	139.3	1.39
BP138	141.3	1.41
BP140	143.3	1.43
BP141	144.3	1.44
BP142	145.3	1.45
BP144	147.3	1.48
BP146	149.3	1.49

Part Number	Outside Circumference	Weight (lbs)
B Section – Recommended Sheaves: Conventional – QD, Taper Bushed, or MST (A-B)		
BP148	151.3	1.51
BP150	153.3	1.53
BP151	154.3	1.54
BP152	155.3	1.55
BP154	157.3	1.57
BP156	159.3	1.59
BP157	160.3	1.60
BP158	161.3	1.61
BP160	163.3	1.64
BP161	164.3	1.65
BP162	165.3	1.66
BP164	167.3	1.68
BP165	168.3	1.69
BP168	171.3	1.72
BP170	173.3	1.74
BP172	175.3	1.76
BP173	176.3	1.77
BP175	178.3	1.79
BP176	179.3	1.80
BP180	183.3	1.84
BP182	185.3	1.86
BP184	187.3	1.88
BP190	193.3	1.94
BP191	194.3	1.95
BP195	198.3	1.99
BP198	201.3	2.02
BP203	206.3	2.05
BP205	208.3	2.07
BP210	213.3	2.12
BP214	217.3	2.16
BP217*	220.3	2.19
BP220	223.3	2.22
BP221	224.3	2.23

Super Blue Ribbon® V-Belt

Part Number Example: **CP50** = **C** **P** **50**
↑ ↑ ↑
Cross Wrapped Molded Inside Circumference
Section Construction (inches)

Part Number	Outside Circumference	Weight (lbs)
B Section – Recommended Sheaves: Conventional – QD, Taper Bushed, or MST (A-B)		
BP224*	227.3	2.25
BP225	228.3	2.26
BP228	231.3	2.30
BP240	241.7	2.41
BP250	251.7	2.52
BP253*	254.7	2.55
BP255	256.7	2.56
BP265	266.7	2.67
BP270	271.7	2.71
BP280	281.7	2.81
BP285	286.7	2.86
BP300	301.7	3.01
BP315	316.7	3.16
BP330	331.7	3.31
BP360	361.7	3.68
BP361*	362.7	3.70
BP364*	365.7	3.80
BP433*	434.7	4.43
BP443*	444.7	4.53
BP512	513.7	5.22
BP543*	544.7	5.53
BP553*	554.7	5.64
C Section – Recommended Sheaves: Conventional – QD, Taper Bushed, or MST (C)		
CP46	50.4	0.79
CP50	54.4	0.91
CP51	55.4	0.98
CP53	57.4	1.01
CP54	58.4	1.04
CP55	59.4	1.06
CP56	60.4	1.01
CP57	61.4	1.04
CP58	62.4	1.00

Part Number	Outside Circumference	Weight (lbs)
C Section – Recommended Sheaves: Conventional – QD, Taper Bushed, or MST (C)		
CP60	64.4	1.15
CP61	65.4	1.16
CP62	66.4	1.18
CP63	67.4	1.20
CP64	68.4	1.22
CP65	69.4	1.10
CP66	70.4	1.25
CP67	71.4	1.27
CP68	72.4	1.29
CP69	73.4	1.30
CP70	74.4	1.27
CP71	75.4	1.34
CP72	76.4	1.36
CP73	77.4	1.38
CP74	78.4	1.40
CP75	79.4	1.46
CP76	80.4	1.49
CP77	81.4	1.50
CP78	82.4	1.52
CP79	83.4	1.54
CP80	84.4	1.55
CP81	85.4	1.58
CP82	86.4	1.59
CP83	87.4	1.61
CP84	88.4	1.63
CP85	89.4	1.65
CP86	90.4	1.67
CP87	91.4	1.69
CP88	92.4	1.71
CP89	93.4	1.73
CP90	94.4	1.74
CP91	95.4	1.76
CP92	96.4	1.79

Heavy Duty V-Belts

Super Blue Ribbon®

V-Belt

Super Blue Ribbon® Part Numbers

Part Number	Outside Circumference	Weight (lbs)
C Section – Recommended Sheaves: Conventional – QD, Taper Bushed, or MST (C)		
CP93	97.4	1.81
CP94	98.4	1.82
CP95	99.4	1.84
CP96	100.4	1.86
CP97	101.4	1.88
CP98	102.4	1.90
CP99	103.4	1.92
CP100	104.4	1.94
CP101	105.4	1.96
CP102	106.4	1.97
CP103	107.4	1.99
CP104	108.4	2.01
CP105	109.4	2.03
CP106	110.4	2.04
CP107	111.4	2.07
CP108	112.4	2.09
CP109	113.4	2.10
CP110	114.4	2.12
CP111	115.4	2.14
CP112	116.4	2.16
CP113	117.4	2.18
CP114	118.4	2.20
CP115	119.4	2.22
CP116	120.4	2.23
CP117	121.4	2.25
CP118	122.4	2.27
CP119	123.4	2.29
CP120	124.4	2.31
CP121	125.4	2.33
CP122	126.4	2.34
CP123	127.4	2.37
CP124	128.4	2.38
CP125	129.4	2.40

Part Number	Outside Circumference	Weight (lbs)
C Section – Recommended Sheaves: Conventional – QD, Taper Bushed, or MST (C)		
CP126	130.4	2.42
CP127	131.4	2.44
CP128	132.4	2.46
CP129	133.4	2.48
CP130	134.4	2.50
CP131	135.4	2.52
CP132	136.4	2.53
CP133	137.4	2.55
CP134	138.4	2.57
CP135	139.4	2.59
CP136	140.4	2.61
CP137	141.4	2.63
CP138	142.4	2.66
CP139	143.4	2.57
CP140	144.4	2.68
CP141	145.4	2.70
CP142	146.4	2.72
CP143	147.4	2.74
CP144	148.4	2.76
CP145	149.4	2.78
CP146	150.4	2.80
CP147	151.4	2.81
CP148	152.4	2.83
CP149	153.4	2.85
CP150	154.4	2.87
CP151	155.4	2.89
CP152	156.4	2.91
CP153	157.4	2.93
CP154	158.4	2.95
CP155	159.4	2.97
CP156	160.4	2.98
CP157	161.4	3.00
CP158	162.4	3.02

Super Blue Ribbon®

V-Belt

Part Number Example: **CP200** = **C** **P** **200**
↓ ↓ ↓
Cross Wrapped Molded Inside Circumference
Section Construction (inches)

Part Number	Outside Circumference	Weight (lbs)
C Section – Recommended Sheaves: Conventional – QD, Taper Bushed, or MST (C)		
CP159	163.4	3.04
CP160	164.4	3.06
CP161	165.4	3.08
CP162	166.4	3.10
CP163	167.4	3.12
CP164	168.4	3.13
CP165	169.4	3.15
CP166	170.4	3.17
CP167	171.4	3.19
CP168	172.4	3.21
CP169	173.4	3.23
CP170	174.4	3.25
CP171	175.4	3.27
CP172*	176.4	3.28
CP173	177.4	3.30
CP174	178.4	3.32
CP175	179.4	3.34
CP176	180.4	3.36
CP177	181.4	3.38
CP178	182.4	3.40
CP180	184.4	3.43
CP181	185.4	3.46
CP182	186.4	3.47
CP183	187.4	3.49
CP184	188.4	3.51
CP185	189.4	3.53
CP186	190.4	3.55
CP187	191.4	3.57
CP188	192.4	3.58
CP189	193.4	3.60
CP190	194.4	3.62
CP193	197.4	3.68
CP194	198.4	3.70

Part Number	Outside Circumference	Weight (lbs)
C Section – Recommended Sheaves: Conventional – QD, Taper Bushed, or MST (C)		
CP195	199.4	3.72
CP196	200.4	3.73
CP197	201.4	3.75
CP198	202.4	3.77
CP200	204.4	3.81
CP204	208.4	3.76
CP205	209.4	3.78
CP208	212.4	3.83
CP210	214.4	3.87
CP215	219.4	3.96
CP218	222.4	4.02
CP220	224.4	4.05
CP225	229.4	4.11
CP228	232.4	4.16
CP230	234.4	4.20
CP235	239.4	4.29
CP236*	240.4	4.31
CP240	242.5	4.38
CP245	247.5	4.47
CP248	250.5	4.52
CP250*	252.5	4.56
CP255	257.5	4.65
CP260	262.5	4.74
CP264*	266.5	4.81
CP265	267.5	4.83
CP269*	271.5	4.90
CP270	272.5	4.92
CP275	277.5	5.01
CP276*	278.5	5.03
CP280	282.5	5.12
CP285	287.5	5.19
CP290	292.5	5.28
CP297*	299.5	5.41

Heavy Duty V-Belts

Super Blue Ribbon®

V-Belt

Super Blue Ribbon® Part Numbers

Part Number	Outside Circumference	Weight (lbs)
C Section – Recommended Sheaves: Conventional – QD, Taper Bushed, or MST (C)		
CP300	302.5	5.47
CP314*	316.5	5.72
CP315	317.5	5.74
CP330	332.5	6.01
CP340*	342.5	6.19
CP345	347.5	6.28
CP360	362.5	6.65
CP390	392.5	7.20
CP420	422.5	7.75
D Section – Recommended Sheaves: Conventional – QD, Taper Bushed, or MST (D)		
DP88*	93.5	3.02
DP90	95.5	3.08
DP96	101.5	3.28
DP100	105.5	3.41
DP101*	106.5	3.45
DP104	109.5	3.54
DP105	110.5	3.58
DP108	113.5	3.68
DP112	117.5	3.81
DP115*	120.5	3.91
DP120	125.5	4.33
DP124*	129.5	4.13
DP128	133.5	4.61
DP132	137.5	4.47
DP135	140.5	4.57
DP136	141.5	4.60
DP144	149.5	4.85
DP152	157.5	5.11
DP158	163.5	5.31
DP160*	165.5	5.37
DP162	167.5	5.44
DP164	169.5	5.50

Part Number	Outside Circumference	Weight (lbs)
D Section – Recommended Sheaves: Conventional – QD, Taper Bushed, or MST (D)		
DP165	170.5	5.54
DP166	171.5	5.57
DP170*	175.5	5.70
DP171	176.5	5.73
DP173	178.5	5.80
DP178	183.5	5.96
DP180	185.5	6.03
DP189	194.5	6.33
DP195	200.5	6.52
DP210	215.5	7.02
DP225	230.5	7.43
DP230*	235.5	7.59
DP240	243.0	7.92
DP255	258.0	8.41
DP260*	263.0	8.58
DP270	273.0	8.91
DP280	283.0	9.23
DP285	288.0	9.40
DP300	303.0	9.89
DP315	318.0	10.38
DP330	333.0	10.88
DP345	348.0	11.37
DP360	363.0	12.01
DP390	393.0	13.01
DP420	423.0	14.01
DP450*	453.0	15.20
DP480*	483.0	16.20
DP540	543.0	18.22
DP600*	603.0	20.60
DP660*	663.0	22.25

Super Blue Ribbon® V-Belt

Part Number Example: **DP300** = **D** **P** **300**
↓ ↓ ↓
Cross Wrapped Molded Inside Circumference
Section Construction (inches)

Part Number	Outside Circumference	Weight (lbs)
E Section – Recommended Sheaves: Conventional – OD, Taper Bushed, or MST (E*)		
EP144*	150.2	7.90
EP180*	186.2	9.82
EP195*	201.2	10.70
EP210*	216.2	11.42
EP225*	231.2	12.03
EP240	243.7	12.83
EP270	273.7	14.43
EP300	303.7	16.02
EP330	333.7	17.62
EP360	363.7	19.32
EP390*	393.7	20.93
EP420*	423.7	22.54
EP441*	444.7	23.70
EP480*	483.7	25.75
EP540*	543.7	28.96
EP600*	603.7	32.20
EP660*	663.7	35.39

*Non-stock item. Minimum order quantity and/or extended lead times may apply. Contact customer service for availability.

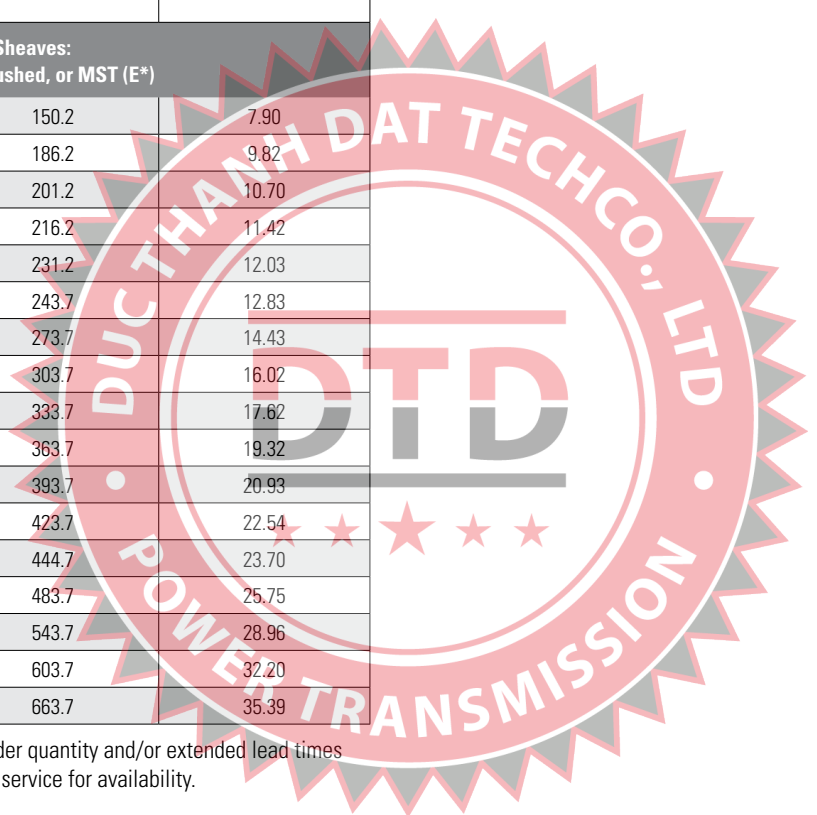

Heavy Duty V-Belts

Aramax® Xtra Duty

V-Belt



Aramax[®] Xtra Duty V-Belt



1 Aramid Tensile Cords
Carries load with increased strength and durability

2 Rubber Compound
New and improved compound for longer belt life

3 Clutching Cover
Superior fabric for smoother clutching and resistance to rollover

New and improved premium rubber compound provides longer belt life

Smooth clutching cover for shock-loaded, backside-idler drives

Superior shock resistance

Applications:
Outdoor power Equipment including
Lawnmowers
Edgers
Snow blowers
& More

Recommended Sheaves:
Conventional – OD, Taper Bushed, or MST (A-B)

Heavy Duty V-Belts

Aramax® Xtra Duty

V-Belt

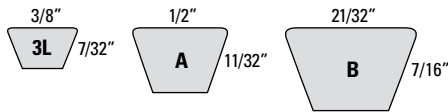

Specifically designed for aggressive applications with heavy shock loads and backside-idler driven equipment.

Performance Driven... Performance Proven

- Aramax® Xtra Duty v-belts are designed for outdoor power equipment. Aramax features a brown smooth clutching cover and strong aramid cord. This high performance construction delivers more horsepower, less stretch and longer service life.

Sizes

- 3L, A, B section belts
- 3L sizes use industry standard part number ending in K
- Classical part numbers are AK, BK
 - Dual branded with ASABE length designations HA, HB

Features/Advantages

- Superior clutching fabric
 - Smoother clutching
 - Increased thread count
 - Resistance to rollover
- Aramid tensile cords
 - Increased strength and durability
 - Reduced stretch
- Oil and heat resistant

Please note: When Aramax belts are used as a matched set, all belts must have the same SAG number. These high modulus aramid cord belts require closer matching than standard belts in order to tension properly and work together as a set.

Part Number	Outside Circumference	Weight (lbs)
3L Section – Recommended Sheaves: Conventional – OD, Taper Bushed, or MST (3L*)		
3L150K*	15.1	0.05
3L160K*	16.1	0.05
3L170K*	17.1	0.05
3L180K*	18.1	0.06
3L190K	19.1	0.06
3L200K*	20.1	0.06
3L210K*	21.1	0.06
3L220K	22.1	0.07
3L230K*	23.1	0.07
3L240K*	24.1	0.07
3L250K*	25.1	0.08
3L260K*	26.1	0.08
3L270K*	27.1	0.08
3L280K	28.1	0.09
3L290K	29.1	0.09
3L300K*	30.1	0.09
3L310K	31.1	0.09
3L320K	32.1	0.10
3L330K	33.1	0.10
3L340K	34.1	0.11
3L350K	35.1	0.11
3L360K*	36.1	0.11
3L370K	37.1	0.11
3L380K	38.1	0.12
3L390K	39.1	0.12
3L400K*	40.1	0.12
3L410K	41.1	0.12
3L420K*	42.1	0.13
3L430K*	43.1	0.13
3L440K	44.1	0.13
3L450K*	45.1	0.14
3L460K*	46.1	0.14
3L470K*	47.1	0.14

Aramax® Xtra Duty V-Belt

V-Belt

Aramax® Xtra Duty V-Belt Part Numbers

Part Number Example: **AK15** =



Part Number	Outside Circumference	Weight (lbs)
3L Section – Recommended Sheaves: Conventional – QD, Taper Bushed, or MST (3L*)		
3L480K*	48.1	0.15
3L490K*	49.1	0.15
3L500K*	50.1	0.15
3L510K*	51.1	0.15
3L520K*	52.1	0.16
3L530K*	53.1	0.16
3L540K*	54.1	0.16
3L550K*	55.1	0.17
3L560K*	56.1	0.17
3L570K*	57.1	0.17
3L580K*	58.1	0.18
3L590K*	59.1	0.18
3L600K*	60.1	0.18
3L610K*	61.1	0.18
3L620K*	62.1	0.19
3L740K*	74.1	0.22
A Section – Recommended Sheaves: Conventional – QD, Taper Bushed, or MST (A-B)		
AK15	17.3	0.09
AK16	18.3	0.09
AK17*	19.3	0.10
AK18	20.3	0.10
AK19	21.3	0.11
AK20	22.3	0.11
AK21	23.3	0.13
AK22	24.3	0.13
AK23	25.3	0.14
AK24	26.3	0.14
AK25	27.3	0.15
AK26	28.3	0.16
AK27	29.3	0.16
AK28	30.3	0.17
AK29	31.3	0.17

Part Number	Outside Circumference	Weight (lbs)
A Section – Recommended Sheaves: Conventional – QD, Taper Bushed, or MST (A-B)		
AK30	32.3	0.18
AK31	33.3	0.18
AK32	34.3	0.19
AK33	35.3	0.20
AK34	36.3	0.20
AK35	37.3	0.21
AK36	38.3	0.21
AK37	39.3	0.22
AK38	40.3	0.22
AK39	41.3	0.23
AK40	42.3	0.23
AK41	43.3	0.24
AK42	44.3	0.25
AK43	45.3	0.25
AK44	46.3	0.26
AK45	47.3	0.26
AK46	48.3	0.27
AK47	49.3	0.27
AK48	50.3	0.28
AK49	51.3	0.28
AK50	52.3	0.29
AK51	53.3	0.30
AK52	54.3	0.30
AK53	55.3	0.31
AK54	56.3	0.31
AK55	57.3	0.32
AK56	58.3	0.32
AK57	59.3	0.33
AK58	60.3	0.33
AK59	61.3	0.34
AK60	62.3	0.35
AK61	63.3	0.35
AK62	64.3	0.36

Heavy Duty V-Belts

Aramax® Xtra Duty

V-Belt

Aramax® Xtra Duty V-Belt Part Numbers

Part Number	Outside Circumference	Weight (lbs)
A Section – Recommended Sheaves: Conventional – QD, Taper Bushed, or MST (A-B)		
AK63	65.3	0.36
AK64	66.3	0.37
AK65	67.3	0.37
AK66	68.3	0.38
AK67	69.3	0.39
AK68	70.3	0.39
AK69	71.3	0.40
AK70	72.3	0.40
AK71	73.3	0.41
AK72	74.3	0.41
AK73	75.3	0.42
AK74	76.3	0.42
AK75	77.3	0.43
AK76	78.3	0.44
AK77	79.3	0.44
AK78	80.3	0.45
AK79	81.3	0.45
AK80	82.3	0.46
AK81	83.3	0.46
AK82	84.3	0.47
AK83	85.3	0.47
AK84	86.3	0.48
AK85	87.3	0.49
AK86	88.3	0.49
AK87	89.3	0.50
AK88	90.3	0.50
AK89	91.3	0.51
AK90	92.3	0.51
AK91	93.3	0.52
AK92	94.3	0.53
AK93	95.3	0.53
AK94	96.3	0.54
AK95	97.3	0.54

Part Number	Outside Circumference	Weight (lbs)
A Section – Recommended Sheaves: Conventional – QD, Taper Bushed, or MST (A-B)		
AK96	98.3	0.55
AK97	99.3	0.55
AK98	100.3	0.56
AK100*	102.3	0.57
AK101	103.3	0.58
AK103	105.3	0.59
AK105*	107.3	0.60
AK112*	114.3	0.64
AK115*	117.3	0.70
B Section – Recommended Sheaves: Conventional – QD, Taper Bushed, or MST (A-B)		
BK20*	23.3	0.18
BK21	24.3	0.19
BK22*	25.3	0.19
BK23*	26.3	0.20
BK24*	27.3	0.21
BK25*	28.3	0.22
BK26	29.3	0.23
BK27	30.3	0.23
BK28	31.3	0.29
BK29	32.3	0.25
BK30	33.3	0.26
BK31	34.3	0.27
BK32	35.3	0.33
BK33	36.3	0.34
BK34	37.3	0.35
BK35	38.3	0.36
BK36	39.3	0.37
BK37	40.3	0.38
BK38	41.3	0.39
BK39	42.3	0.40
BK40	43.3	0.41
BK41	44.3	0.42

Aramax® Xtra Duty V-Belt

Part Number Example: **BK50** = **B** = Cross Section, **K** = Aramid Cord Construction, **50** = Inside Circumference (inches)

Part Number	Outside Circumference	Weight (lbs)
B Section – Recommended Sheaves: Conventional – QD, Taper Bushed, or MST (A-B)		
BK42	45.3	0.42
BK43	46.3	0.44
BK44	47.3	0.45
BK45	48.3	0.46
BK46	49.3	0.47
BK47	50.3	0.47
BK48	51.3	0.48
BK49	52.3	0.49
BK50	53.3	0.50
BK51	54.3	0.52
BK52	55.3	0.52
BK53	56.3	0.53
BK54	57.3	0.54
BK55	58.3	0.56
BK56	59.3	0.56
BK57	60.3	0.57
BK58	61.3	0.58
BK59	62.3	0.59
BK60	63.3	0.60
BK61	64.3	0.61
BK62	65.3	0.62
BK63	66.3	0.63
BK64	67.3	0.64
BK65	68.3	0.65
BK66	69.3	0.66
BK67	70.3	0.67
BK68	71.3	0.68
BK69	72.3	0.69
BK70	73.3	0.70
BK71	74.3	0.71
BK72	75.3	0.72
BK73	76.3	0.73
BK74	77.3	0.74

Part Number	Outside Circumference	Weight (lbs)
B Section – Recommended Sheaves: Conventional – QD, Taper Bushed, or MST (A-B)		
BK75	78.3	0.75
BK76	79.3	0.76
BK77	80.3	0.77
BK78	81.3	0.78
BK79	82.3	0.79
BK80	83.3	0.80
BK81	84.3	0.81
BK82	85.3	0.82
BK83	86.3	0.83
BK84*	87.3	0.84
BK85	88.3	0.85
BK86	89.3	0.86
BK87	90.3	0.87
BK88	91.3	0.88
BK89*	92.3	0.89
BK90	93.3	0.90
BK91*	94.3	0.91
BK92*	95.3	0.92
BK93	96.3	0.92
BK94	97.3	0.93
BK95*	98.3	0.94
BK96*	99.3	0.95
BK97*	100.3	0.96
BK98	101.3	0.97
BK100	102.9	0.99

*Non-stock item. Minimum order quantity and/or extended lead times may apply. Contact customer service for availability.

Heavy Duty V-Belts

Power-Wedge® Cog-Belt®

V-Belt

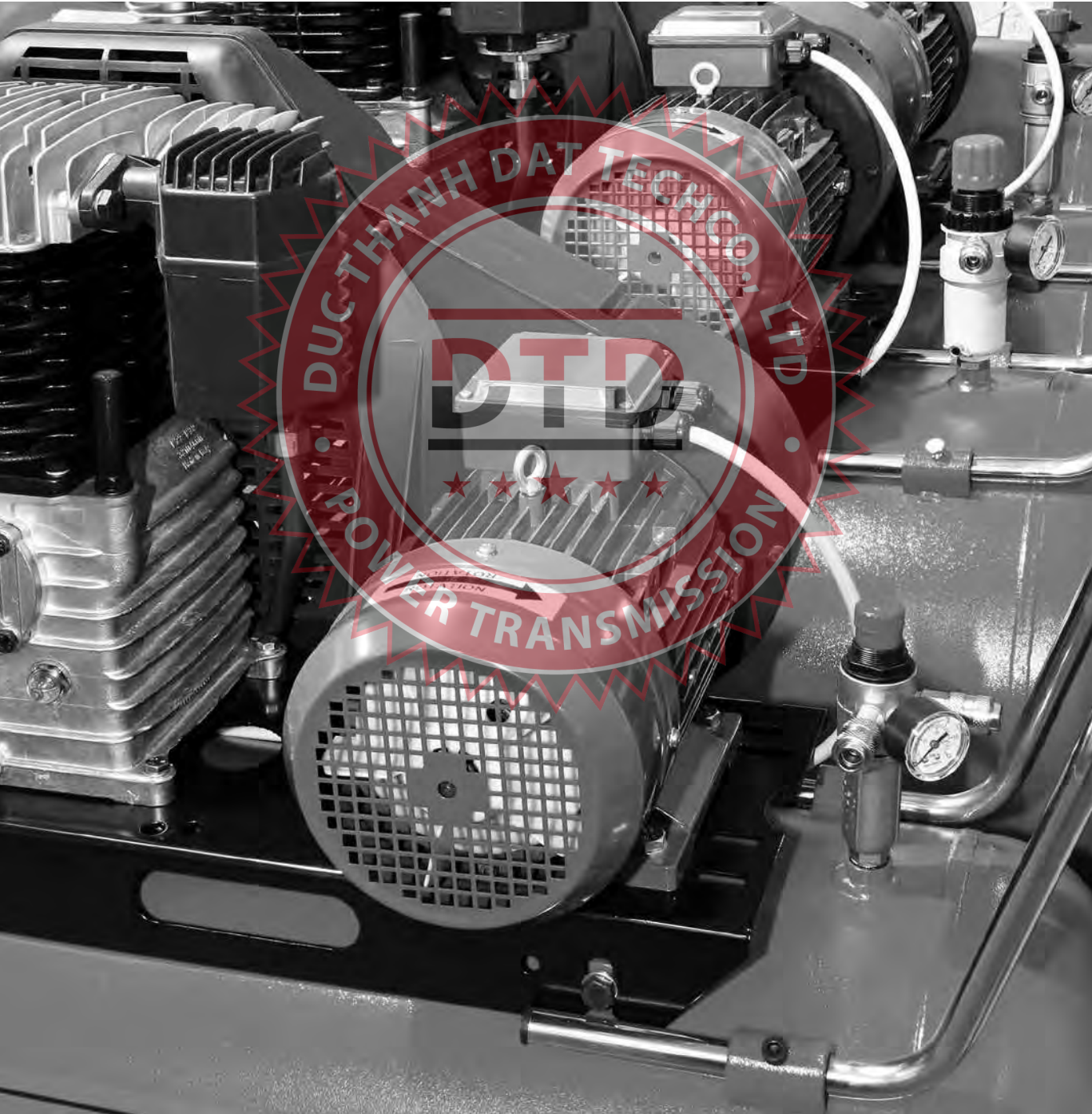

Power-Wedge® Cog-Belt®

V-Belt

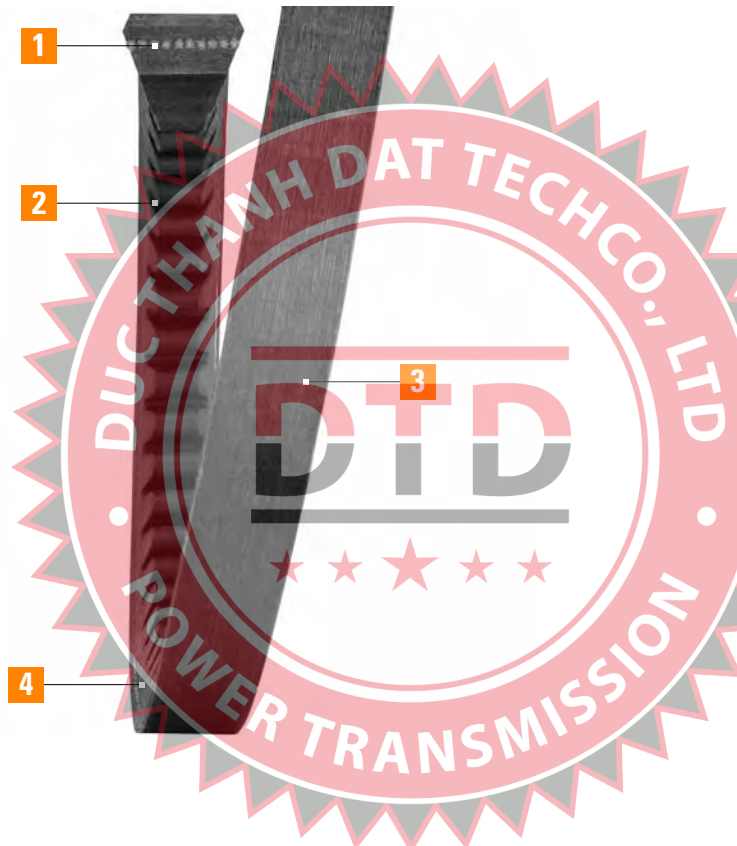

1 High-Modulus Cords

Carries high horsepower loads with minimum stretch. Better belt stability. Fewer take-up adjustments.

2 Precision Molded Cogs

Improves belt flex, reduces bending stress. Helps dissipate heat and requires less power. Improves flexibility for increased performance on small diameter pulleys.

3 EPDM Construction

EPDM offers superior flex and load carrying capacity. It resists belt cracking and won't stretch. EPDM has excellent flexibility at high and low temperatures.

4 Raw Edge Side Walls

Produces a higher coefficient of friction. Keeps a tighter grip on the sheave to reduce slippage. Improves performance and efficiency. Reduces vibration for extended component life.

Recommended Sheaves:

Hi-Cap Wedge – QD, Taper Bushed, or MST (3V, 5V, 8V)

Energy efficient

Smoother running

Design flexibility

High performance
EPDM construction:

High HP ratings

Longer belt life

Oil and heat resistant

Resists hardening
and glazing

Broad operating
temperature range
(-50°F to +250°F)

checkmate
matching

Static conductive

Imperial and metric
cross-sections

Applications:

Fans
Pumps
HVAC
Compressors
& More

Heavy Duty V-Belts

Power-Wedge® Cog-Belt®

V-Belt

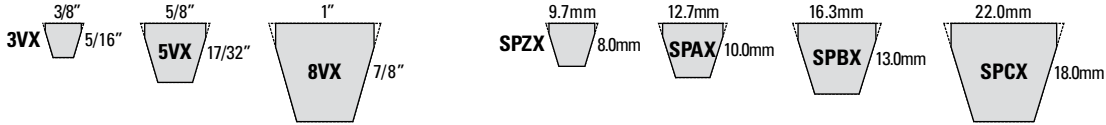

The Power-Wedge® Cog-Belt® combines the advantages of the narrow belt wedge design with raw edge performance for maximum operating efficiency in a compact drive package – now made of EPDM (Ethylene Propylene Diene Monomer), a synthetic rubber with outstanding properties.

More Grip... Less Slip

Our Power-Wedge® Cog-Belt® provides more torque with little or no slippage. The result is savings – in time, in belt life and in energy costs.

The narrow profile permits reduced drive widths and a smaller drive envelope. Higher horsepower ratings translate into greater design flexibility – reducing drive cost, space and weight.

The Power-Wedge Cog-Belt is available in 3VX, 5VX, and 8VX cross sections as well as metric sizes SPZX, SPAX, SPBX, and SPCX. Where applicable, belts are dual branded with imperial and metric part numbers.



Horsepower Ratings Comparison

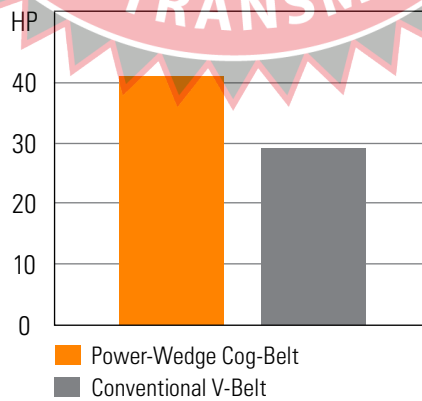

5V Section Drive
1750 RPM
1.5:1 Belt Drive Ratio

Power-Wedge® Cog-Belt® V-Belt

Power-Wedge® Cog-Belt® Part Numbers

Part Number Example: **5VX500** = **5V** **X** **500**
Cross Section Cogged Construction Effective Length (inches in tenths: 50.0")

Part Number	Effective Length (in)	Metric Number	Weight (lbs)
3V Section – Recommended Sheaves: Hi-Cap Wedge – QD, Taper Bushed, or MST (3V)			
3VX250	24.9	9XN630	0.08
3VX265	26.5	9XN670	0.08
3VX280	28.0	9XN710	0.09
3VX300	29.9	9XN760	0.09
3VX315	31.5	9XN800	0.10
3VX335	33.3	9XN850	0.10
3VX355	35.6	9XN900	0.11
3VX375	37.5	9XN950	0.12
3VX400	40.0	9XN1015	0.13
3VX425	42.5	9XN1080	0.13
3VX450	45.0	9XN1145	0.14
3VX475	47.5	9XN1205	0.14
3VX500	50.0	9XN1270	0.16
3VX530	52.9	9XN1345	0.17
3VX560	56.0	9XN1420	0.18
3VX600	60.1	9XN1525	0.19
3VX630	62.9	9XN1600	0.20
3VX670	67.0	9XN1700	0.21
3VX710	71.1	9XN1800	0.22
3VX750	74.8	9XN1900	0.23
3VX800	79.9	9XN2030	0.25
3VX850	84.9	9XN2160	0.27
3VX900	89.9	9XN2290	0.28
3VX950	94.9	9XN2410	0.30
3VX1000	100.0	9XN2540	0.31
3VX1060	105.9	9XN2690	0.33
3VX1120	111.9	9XN2840	0.35
3VX1180	117.9	9XN3000	0.37
3VX1250	125.0	9XN3180	0.39
3VX1320	132.0	9XN3350	0.41
3VX1400	140.0	9XN3550	0.44
3VX1500	150.0	9XN3810	0.47

Part Number	Effective Length (in)	Metric Number	Weight (lbs)
5V Section – Recommended Sheaves: Hi-Cap Wedge – QD, Taper Bushed, or MST (5V)			
5VX450	45.0	15XN1150	0.36
5VX470	46.9	15XN1190	0.38
5VX490	49.0	15XN1250	0.40
5VX500	50.0	15XN1270	0.40
5VX510	51.0	15XN1290	0.41
5VX530	53.1	15XN1345	0.43
5VX540	53.9	15XN1370	0.44
5VX550	55.0	15XN1400	0.44
5VX560	56.0	15XN1420	0.45
5VX570	56.9	15XN1450	0.46
5VX580	57.9	15XN1470	0.47
5VX590	59.1	15XN1500	0.48
5VX600	60.1	15XN1525	0.64
5VX610	61.0	15XN1550	0.49
5VX630	62.9	15XN1600	0.51
5VX650	65.1	15XN1650	0.53
5VX660	66.0	15XN1680	0.53
5VX670	67.0	15XN1700	0.54
5VX680	67.9	15XN1730	0.55
5VX690	68.9	15XN1750	0.56
5VX710	71.1	15XN1800	0.57
5VX730	72.9	15XN1850	0.59
5VX740	73.9	15XN1880	0.59
5VX750	75.1	15XN1900	0.60
5VX780	78.0	15XN1980	0.63
5VX790	78.9	15XN2000	0.63
5VX800	79.9	15XN2030	0.64
5VX810	80.8	15XN2060	0.65
5VX830	83.0	15XN2110	0.67
5VX840	83.9	15XN2130	0.67
5VX850	84.9	15XN2160	0.68
5VX860	85.8	15XN2180	0.69
5VX880	88.0	15XN2240	0.71

Heavy Duty V-Belts

Power-Wedge® Cog-Belt®

V-Belt

Power-Wedge® Cog-Belt® Part Numbers

Part Number Example: **5VX1000** =

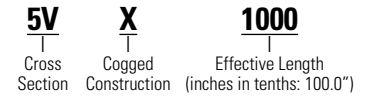

Part Number	Effective Length (in)	Metric Number	Weight (lbs)
5V Section – Recommended Sheaves: Hi-Cap Wedge – QD, Taper Bushed, or MST (5V)			
5VX900	89.9	15XN2290	0.72
5VX930	93.0	15XN2360	0.75
5VX950	94.9	15XN2410	0.76
5VX960	95.9	15XN2440	0.77
5VX990	99.0	15XN2500	0.79
5VX1000	100.0	15XN2540	0.80
5VX1030	102.8	15XN2620	0.82
5VX1060	105.9	15XN2690	0.85
5VX1080	108.1	15XN2740	0.87
5VX1120	111.9	15XN2840	0.90
5VX1150	115.0	15XN2920	0.92
5VX1160	116.3	15XN2950	0.93
5VX1180	118.2	15XN3000	0.95
5VX1230	123.0	15XN3130	0.99
5VX1250	125.0	15XN3180	1.00
5VX1320	132.0	15XN3350	1.06
5VX1400	140.0	15XN3550	1.12
5VX1500	150.0	15XN3810	1.20
5VX1600	160.0	15XN4060	1.28
5VX1700	170.0	15XN4320	1.36
5VX1800	180.0	15XN4570	1.44
5VX1900	190.0	15XN4830	1.52
5VX2000	200.0	15XN5080	1.60

Part Number	Effective Length (in)	Metric Number	Weight (lbs)
8V Section – Recommended Sheaves: Hi-Cap Wedge – QD, Taper Bushed, or MST (8V)			
8VX1000	100.0	25XN2540	2.35
8VX1060	106.0	25XN2690	2.49
8VX1120	112.0	25XN2840	2.63
8VX1180	118.0	25XN3000	2.77
8VX1250	125.0	25XN3180	2.93
8VX1320	132.0	25XN3350	3.09
8VX1400	140.0	25XN3550	3.28
8VX1500	150.0	25XN3810	3.51
8VX1600	160.0	25XN4060	3.74
8VX1700	170.0	25XN4320	3.98
8VX1800	180.0	25XN4570	4.21
8VX1900	190.0	25XN4830	4.44
8VX2000	200.0	25XN5080	4.50

Metric Power-Wedge® Cog-Belt® V-Belt

Metric Power-Wedge® Cog-Belt® Part Numbers

Part Number Example: **SPZX1000** = **SPZ** **X** **1000**
Cross Section Cogged Construction Pitch Length (millimeters)

Part Number	Outside Circumference (mm)	Outside Circumference (in)	Datum Length	Weight (lbs)
SPZX Section – Recommended Sheaves: Hi-Cap Wedge – QD, Taper Bushed, or MST (3V)				
SPZX630	643.0	25.3	24.8	0.11
SPZX670	683.0	26.9	26.4	0.12
SPZX710	723.0	28.5	28.0	0.12
SPZX750*	763.0	30.0	29.5	0.13
SPZX800	813.0	32.0	31.5	0.14
SPZX850	863.0	34.0	33.5	0.15
SPZX875	888.0	35.0	34.4	0.15
SPZX900	913.0	35.9	35.4	0.16
SPZX925	938.0	36.9	36.4	0.16
SPZX940	953.0	37.5	37.0	0.16
SPZX950	963.0	37.9	37.4	0.17
SPZX1000	1013.0	39.9	39.4	0.17
SPZX1010	1023.0	40.3	39.8	0.18
SPZX1030	1043.0	41.1	40.6	0.18
SPZX1060	1073.0	42.2	41.7	0.19
SPZX1080	1093.0	43.0	42.5	0.19
SPZX1090	1103.0	43.4	42.9	0.19
SPZX1120	1133.0	44.6	44.1	0.20
SPZX1140	1153.0	45.4	44.9	0.20
SPZX1150	1163.0	45.8	45.3	0.20
SPZX1180	1193.0	47.0	46.5	0.21
SPZX1200	1213.0	47.8	47.2	0.21
SPZX1220	1233.0	48.5	48.0	0.21
SPZX1250	1263.0	49.7	49.2	0.22
SPZX1270	1283.0	50.5	50.0	0.22
SPZX1280*	1293.0	50.9	50.4	0.23
SPZX1320	1333.0	52.5	52.0	0.23
SPZX1340	1353.0	53.3	52.8	0.24
SPZX1360	1373.0	54.1	53.5	0.24
SPZX1400*	1413.0	55.6	55.1	0.25
SPZX1420	1433.0	56.4	55.9	0.25
SPZX1450*	1463.0	57.6	57.1	0.26

Part Number	Outside Circumference (mm)	Outside Circumference (in)	Datum Length	Weight (lbs)
SPZX Section – Recommended Sheaves: Hi-Cap Wedge – QD, Taper Bushed, or MST (3V)				
SPZX1470	1483.0	58.4	57.9	0.26
SPZX1500	1513.0	59.6	59.1	0.26
SPZX1520	1533.0	60.4	59.8	0.19
SPZX1560	1573.0	61.9	61.4	0.28
SPZX1600	1613.0	63.5	63.0	0.28
SPZX1650*	1663.0	65.5	65.0	0.29
SPZX1700	1713.0	67.4	66.9	0.30
SPZX1800	1813.0	71.4	70.9	0.32
SPZX1850*	1863.0	73.3	72.8	0.23
SPZX1900	1913.0	75.3	74.8	0.34
SPZX2000	2013.0	79.3	78.7	0.25
SPZX2030	2043.0	80.4	79.9	0.35
SPZX2120*	2133.0	84.0	83.5	0.26
SPZX2160	2173.0	85.6	85.0	0.38
SPZX2240	2253.0	88.7	88.2	0.28
SPZX2280	2293.0	90.3	89.8	0.40
SPZX2360*	2373.0	93.4	92.9	0.29
SPZX2410	2423.0	95.4	94.9	0.42
SPZX2500*	2513.0	98.9	98.4	0.31
SPZX2540	2553.0	100.5	100.0	0.44
SPZX2650*	2663.0	104.8	104.3	0.33
SPZX2670*	2683.0	105.6	105.1	0.33
SPZX2690	2703.0	106.4	105.9	0.47
SPZX2800*	2813.0	110.7	110.2	0.35
SPZX2840	2853.0	112.3	111.8	0.50
SPZX3000	3013.0	118.6	118.1	0.52
SPZX3150	3163.0	124.5	124.0	0.39
SPZX3170	3183.0	125.3	124.8	0.39
SPZX3350	3363.0	132.4	131.9	0.41
SPZX3450*	3463.0	136.3	135.8	0.58
SPZX3550	3563.0	140.3	139.8	0.44
SPZX3810	3823.0	150.5	150.0	0.47

Heavy Duty V-Belts

Metric Power-Wedge® Cog-Belt®

V-Belt

Metric Power-Wedge® Cog-Belt® Part Numbers

Part Number	Outside Circumference (mm)	Outside Circumference (in)	Datum Length	Weight (lbs)
SPAX Section – Recommended Sheaves: Hi-Cap Wedge – OD, Taper Bushed, or MST (3V, 5V, 8V)				
SPAX800	818.0	32.2	31.5	0.23
SPAX850	868.0	34.2	33.5	0.24
SPAX900	918.0	36.1	35.4	0.26
SPAX925	943.0	37.1	36.4	0.26
SPAX950	968.0	38.1	37.4	0.27
SPAX1000	1018.0	40.1	39.4	0.29
SPAX1060	1078.0	42.4	41.7	0.30
SPAX1090	1108.0	43.6	42.9	0.31
SPAX1120	1138.0	44.8	44.1	0.32
SPAX1150	1168.0	46.0	45.3	0.33
SPAX1180	1198.0	47.2	46.5	0.34
SPAX1220	1238.0	48.7	48.0	0.35
SPAX1250	1268.0	49.9	49.2	0.36
SPAX1280	1298.0	51.1	50.4	0.37
SPAX1320	1338.0	52.7	52.0	0.38
SPAX1360	1378.0	54.3	53.5	0.39
SPAX1400	1418.0	55.8	55.1	0.40
SPAX1450	1468.0	57.8	57.1	0.42
SPAX1500	1518.0	59.8	59.1	0.43
SPAX1532*	1550.0	61.0	60.3	0.44
SPAX1550	1568.0	61.7	61.0	0.45
SPAX1600	1618.0	63.7	63.0	0.46
SPAX1650	1668.0	65.7	65.0	0.48
SPAX1700	1718.0	67.6	66.9	0.49
SPAX1750	1768.0	69.6	68.9	0.51
SPAX1800	1818.0	71.6	70.9	0.35
SPAX1832*	1850.0	72.8	72.1	0.36
SPAX1850	1868.0	73.5	72.8	0.36
SPAX1900	1918.0	75.5	74.8	0.37
SPAX1950	1968.0	77.5	76.8	0.38
SPAX1957*	1975.0	77.8	77.0	0.38
SPAX1982*	2000.0	78.7	78.0	0.39

Part Number	Outside Circumference (mm)	Outside Circumference (in)	Datum Length	Weight (lbs)
SPAX Section – Recommended Sheaves: Hi-Cap Wedge – OD, Taper Bushed, or MST (3V, 5V, 8V)				
SPAX2000	2018.0	79.4	78.7	0.39
SPAX2032*	2050.0	80.7	80.0	0.40
SPAX2057*	2075.0	81.7	81.0	0.40
SPAX2060	2078.0	81.8	81.1	0.40
SPAX2120*	2138.0	84.2	83.5	0.41
SPAX2160*	2178.0	85.7	85.0	0.42
SPAX2180	2198.0	86.5	85.8	0.43
SPAX2182*	2200.0	86.6	85.9	0.43
SPAX2240	2258.0	88.9	88.2	0.44
SPAX2282*	2300.0	90.6	89.8	0.44
SPAX2300*	2318.0	91.3	90.6	0.45
SPAX2360	2378.0	93.6	92.9	0.46
SPAX2432*	2450.0	96.5	95.7	0.47
SPAX2482*	2500.0	98.4	98.4	0.48
SPAX2500	2518.0	99.1	98.4	0.49
SPAX2532*	2550.0	100.4	99.7	0.49
SPAX2582*	2600.0	102.4	101.7	0.50
SPAX2607*	2625.0	103.3	102.6	0.51
SPAX2632*	2650.0	104.3	103.6	0.51
SPAX2650	2668.0	105.0	104.3	0.52
SPAX2682*	2700.0	106.3	105.6	0.52
SPAX2732*	2750.0	108.3	107.6	0.53
SPAX2782*	2800.0	110.2	109.5	0.54
SPAX2800	2818.0	110.9	110.2	0.55
SPAX3000	3018.0	118.8	118.1	0.58
SPAX3150*	3168.0	124.7	124.0	0.61
SPAX3350*	3368.0	132.6	131.9	0.65
SPAX3550	3568.0	140.5	139.8	0.69
SPAX3750	3768.0	148.3	147.6	0.73
SPAX4000*	4018.0	158.2	157.5	0.78
SPAX4250*	4268.0	168.0	167.3	0.83
SPAX4500*	4518.0	177.9	177.2	0.88

Metric Power-Wedge® Cog-Belt® V-Belt

Part Number Example: **SPBX2000** = **SPB** **X** **2000**
Cross Section Cogged Construction Pitch Length (millimeters)

Part Number	Outside Circumference (mm)	Outside Circumference (in)	Datum Length	Weight (lbs)
SPBX Section – Recommended Sheaves: Hi-Cap Wedge – QD, Taper Bushed, or MST (5V)				
SPBX1150*	1172.0	46.1	45.3	0.50
SPBX1200*	1222.0	48.1	47.2	0.38
SPBX1230	1252.0	49.3	49.2	0.40
SPBX1250	1272.0	50.1	49.2	0.55
SPBX1260	1282.0	50.5	49.6	0.40
SPBX1320	1342.0	52.8	52.0	0.58
SPBX1340	1362.0	53.6	52.8	0.59
SPBX1370*	1392.0	54.8	53.9	0.60
SPBX1400*	1422.0	56.0	55.1	0.62
SPBX1410	1432.0	56.4	55.5	0.45
SPBX1450*	1472.0	58.0	57.1	0.46
SPBX1500	1522.0	59.9	59.1	0.66
SPBX1525*	1547.0	60.9	60.0	0.49
SPBX1550*	1572.0	61.9	61.0	0.50
SPBX1600	1622.0	63.9	63.0	0.71
SPBX1650	1672.0	65.8	65.0	0.73
SPBX1700	1722.0	67.8	66.9	0.75
SPBX1750	1772.0	69.8	68.9	0.77
SPBX1800	1822.0	71.7	70.9	0.80
SPBX1850	1872.0	73.7	72.8	0.59
SPBX1900	1922.0	75.7	74.8	0.84
SPBX2000	2022.0	79.6	78.7	0.89
SPBX2020	2042.0	80.4	79.5	0.90
SPBX2060	2082.0	82.0	81.1	0.65
SPBX2120	2142.0	84.3	83.5	0.94
SPBX2150	2172.0	85.5	84.6	0.96
SPBX2180	2202.0	86.7	85.8	0.69
SPBX2240	2262.0	89.1	88.2	0.71
SPBX2280	2302.0	90.6	89.8	1.01
SPBX2360	2382.0	93.8	92.9	0.75
SPBX2410	2432.0	95.7	94.9	1.07

Part Number	Outside Circumference (mm)	Outside Circumference (in)	Datum Length	Weight (lbs)
SPBX Section – Recommended Sheaves: Hi-Cap Wedge – QD, Taper Bushed, or MST (3V, 5V, 8V)				
SPBX2440*	2462.0	96.9	96.1	0.77
SPBX2500	2522.0	99.3	98.4	1.11
SPBX2530	2552.0	100.5	99.6	1.13
SPBX2610*	2632.0	103.6	102.8	0.83
SPBX2650	2672.0	105.2	104.3	0.84
SPBX2680	2702.0	106.4	105.5	0.85
SPBX2740*	2762.0	108.7	107.9	0.87
SPBX2800	2822.0	111.1	110.2	0.89
SPBX2840	2862.0	112.7	111.8	1.27
SPBX2900	2922.0	115.0	114.2	0.92
SPBX2920	2942.0	115.8	115.0	0.93
SPBX3000	3022.0	119.0	118.1	0.95
SPBX3150	3172.0	124.9	124.0	1.00
SPBX3170	3192.0	125.7	124.8	1.00
SPBX3250	3272.0	128.8	128.0	1.03
SPBX3350	3372.0	132.8	131.9	1.06
SPBX3550	3572.0	140.6	139.8	1.12
SPBX3750	3772.0	148.5	147.6	1.19
SPBX3800	3822.0	150.5	149.6	1.20
SPBX3870	3892.0	153.2	152.4	1.23
SPBX4000	4022.0	158.3	157.5	1.27
SPBX4060	4082.0	160.7	159.8	1.28
SPBX4250	4272.0	168.2	167.3	1.35
SPBX4310	4332.0	170.6	169.7	1.36
SPBX4500	4522.0	178.0	177.2	1.42
SPBX4560	4582.0	180.4	179.5	1.44
SPBX4750	4772.0	187.9	187.0	1.50
SPBX4820	4842.0	190.6	189.8	1.52
SPBX5000	5022.0	197.7	196.9	1.58
SPBX5070	5092.0	200.5	199.6	1.60

Continued on next page

Heavy Duty V-Belts

Metric Power-Wedge® Cog-Belt®

V-Belt

Metric Power-Wedge® Cog-Belt® Part Numbers

Part Number Example: **SPCX2000** = **SPC** **X** **2000**
Cross Section Cogged Construction Pitch Length (millimeters)

Part Number	Outside Circumference (mm)	Outside Circumference (in)	Datum Length	Weight (lbs)
SPCX Section – Recommended Sheaves: Hi-Cap Wedge – QD, Taper Bushed, or MST (3V, 5V, 8V)				
SPCX2000	2030.0	79.9	78.7	1.43
SPCX2120	2150.0	84.6	83.5	1.51
SPCX2240	2270.0	89.4	88.2	1.59
SPCX2360	2390.0	94.1	92.9	1.68
SPCX2500	2530.0	99.6	98.4	1.77
SPCX2650	2680.0	105.5	104.3	1.88
SPCX2800	2830.0	111.4	110.2	1.98
SPCX3000	3030.0	119.3	118.1	2.12
SPCX3150	3180.0	125.2	124.0	2.23
SPCX3350	3380.0	133.1	131.9	2.37
SPCX3550	3580.0	140.9	139.8	2.50
SPCX3750	3780.0	148.8	147.6	2.64
SPCX4000	4030.0	158.7	157.5	2.82
SPCX4250	4280.0	168.5	167.3	2.99
SPCX4500	4530.0	178.3	177.2	3.17
SPCX4750	4780.0	188.2	187.0	3.34
SPCX5000	5030.0	198.0	196.9	3.51

*Non-stock item. Minimum order quantity and/or extended lead times may apply. Contact customer service for availability.

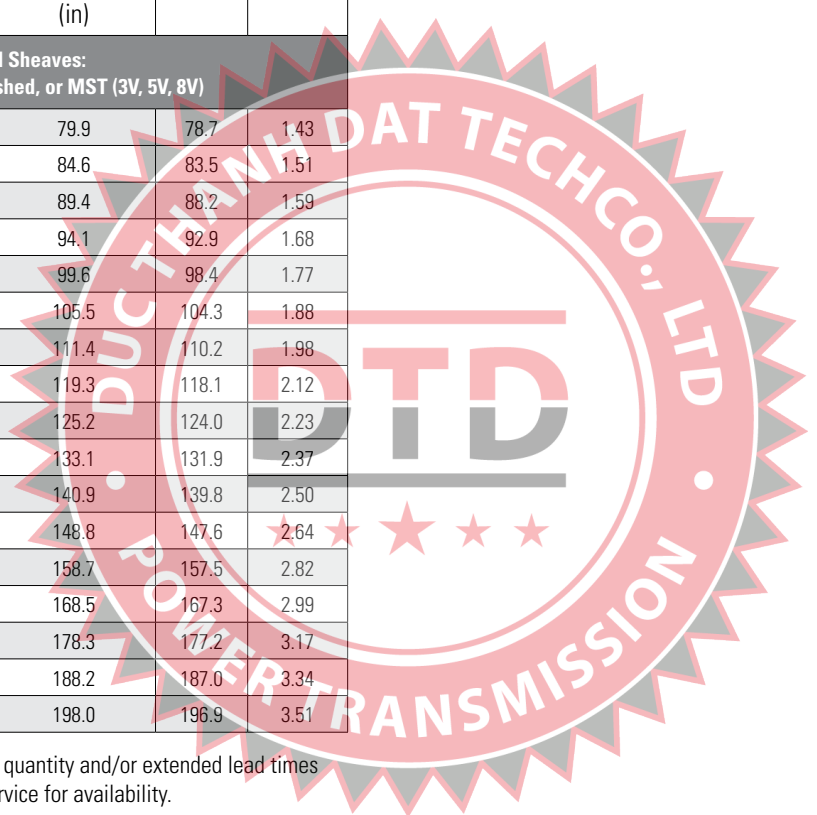

Super Power-Wedge[®] V-Belt

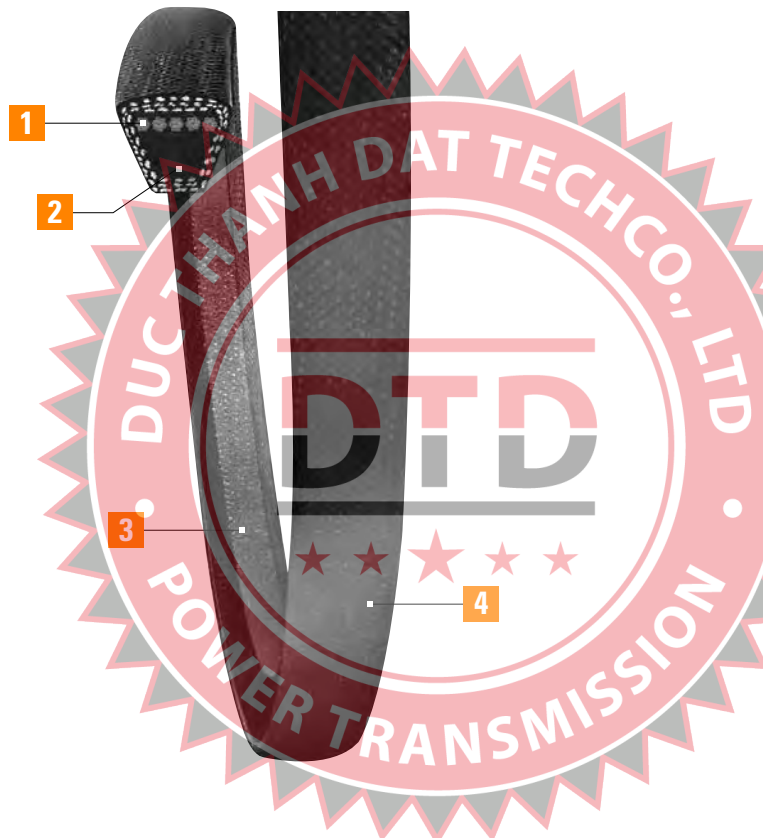

Smooth transfer of power

Greater design flexibility

Longer belt life

Lower cost

Less space

checkmate[®]
matching

Applications:

Pumps
Mixers
& More

1 High-Modulus Cords

Tough enough to carry high HP loads with minimum stretch. Results in better belt stability and fewer take-up adjustments.

2 Maximum Cord Support

Contributes to a quiet, smooth-running belt.

3 Compression Section

Multi-layered compression section features fiber reinforcement to provide excellent support to the cord line while maintaining belt flexibility. Helps eliminate compression cracks and contributes to longer wear.

4 Heavy Duty Cover

Stress-relieved fabric cover flexes better than ordinary fabric to improve belt life. Assures a smooth transfer of power.

Recommended Sheaves:

Hi-Cap Wedge – QD, Taper Bushed, or MST (5V, 8V)

Heavy Duty V-Belts

Super Power-Wedge®

V-Belt

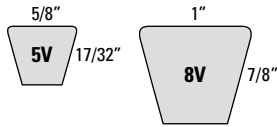

**Super Power-Wedge® enables design of a more compact belt drive.
It's ideal for heavy duty industrial drives with shock loads.**

Super Power-Wedge® is perfect for use in applications requiring long lengths or when cog-belts are too aggressive. It also allows more compact design on multiple belt drives.

- Made of specially formulated rubber compounds
- Heavy duty cover protects against harsh environmental conditions and contributes to longer life in applications where oil, heat and grease exist
- Provides excellent static dissipation
- The proven wedge configuration assures stability when heavy shock loads are encountered
- Delivers an ideal balance between controlled power transfer and slippage



Super Power-Wedge® V-Belt

Super Power-Wedge® Part Numbers

Part Number Example: **5V1000** = **5V** **1000**
Cross Section Effective Length
(inches in tenths: 100.0")

Part Number	Effective Length	Weight (lbs)
5V Section – Recommended Sheaves: Hi-Cap Wedge – QD, Taper Bushed, or MST (5V)		
5V500	50.0	0.59
5V530	53.0	0.62
5V560	56.0	0.66
5V600	60.0	0.71
5V630	63.0	0.74
5V670	67.0	0.79
5V710	71.0	0.84
5V750	75.0	0.89
5V800	80.0	0.94
5V850	85.0	1.00
5V900	90.0	1.06
5V950	95.0	1.12
5V1000	100.0	1.18
5V1060	106.0	1.25
5V1120	112.0	1.33
5V1180	118.0	1.40
5V1250	125.0	1.48
5V1320	132.0	1.56
5V1400	140.0	1.66
5V1500	150.0	1.72
5V1600	160.0	1.84
5V1700	170.0	1.95
5V1800	180.0	2.07
5V1900	190.0	2.19
5V2000	200.0	2.30
5V2120	212.0	2.43
5V2240	224.0	2.57
5V2360	236.0	2.71
5V2500	250.0	2.87
5V2650	265.0	3.05
5V2800	280.0	3.22
5V3000	300.0	3.45
5V3150	315.0	3.62

Part Number	Effective Length	Weight (lbs)
5V Section – Recommended Sheaves: Hi-Cap Wedge – QD, Taper Bushed, or MST (5V)		
5V3350	335.0	3.85
5V3550	335.0	4.09
8V Section – Recommended Sheaves: Hi-Cap Wedge – QD, Taper Bushed, or MST (8V)		
8V1000	100.0	3.08
8V1060	106.0	3.26
8V1120	112.0	3.39
8V1180	118.0	3.63
8V1250	125.0	3.84
8V1320	132.0	4.06
8V1400	140.0	4.30
8V1500	150.0	4.58
8V1600	160.0	4.89
8V1700	170.0	5.20
8V1800	180.0	5.50
8V1900	190.0	5.81
8V2000	200.0	6.12
8V2120	212.0	6.49
8V2240	224.0	6.86
8V2360	236.0	7.24
8V2500	250.0	7.67
8V2650	265.0	8.13
8V2800	280.0	8.60
8V3000	300.0	9.22
8V3150	315.0	9.68
8V3350	335.0	10.30
8V3550	355.0	10.92
8V3750	375.0	11.95
8V4000	400.0	12.75
8V4250	425.0	13.55
8V4500	450.0	14.36
8V4750*	475.0	15.19
8V5000*	500.0	15.99

*Non-stock item. Minimum order quantity and/or extended lead times may apply. Contact customer service for availability.

Double Angle

V-Belt



Double Angle V-Belt

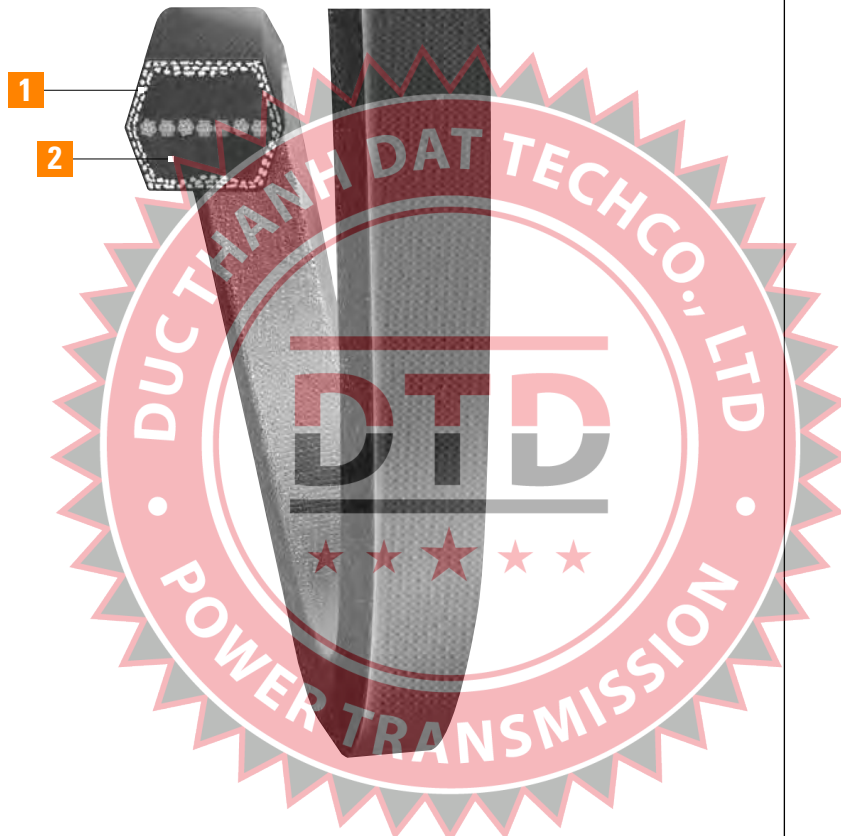

Applications:
Conveyors
Mills
Cooling or
heating drums
& More

1 Double wrapped heavy duty fabric assures maximum resistance to heat, sunlight, grease, oil and dirt.

2 The core of the belt is made of a special blend of compounds to provide long life and superior horsepower capacity.

Recommended Sheaves:
Conventional – OD, Taper Bushed, or MST (B, C)

Double Angle

V-Belt

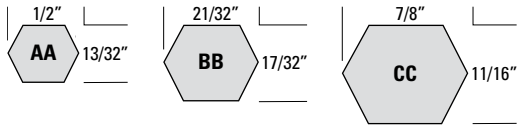

Double Angle V-Belt Part Numbers

Ideally suited for serpentine drives where power needs to be transmitted equally from both sides of the belt.



- Heavy-duty wrapped cover provides excellent resistance to abrasive wear, heat, ozone, grease, oil, or dirt
- Centrally located cord and special synthetic rubber compounds assure long v-belt life and smooth, capable horsepower capacity
- Available in AA, BB, and CC cross sections

Part Number	Outside Circumference	Weight (lbs)
AA Section – Recommended Sheaves: Conventional – QD, Taper Bushed, or MST (B)		
AA51	54.3	0.40
AA55	58.3	0.43
AA60	63.3	0.47
AA62	65.3	0.49
AA64	67.3	0.50
AA66	69.3	0.52
AA68	71.3	0.53
AA70	73.3	0.55
AA75	78.3	0.58
AA78	81.3	0.61
AA80	83.3	0.63
AA85	88.3	0.66
AA90	93.3	0.69
AA92*	95.3	0.72
AA96	99.3	0.75
AA105	108.3	0.82
AA112	115.3	0.87
AA120	123.3	0.93
AA128	131.3	0.99
AA130*	133.3	1.00
AA131*	134.3	1.01
AA136*	139.3	1.05
AA148	151.3	1.14
BB Section – Recommended Sheaves: Conventional – QD, Taper Bushed, or MST (B)		
BB42*	46.5	0.57
BB43	47.5	0.58
BB45*	49.5	0.60
BB51	55.5	0.69
BB53	57.5	0.72
BB54	58.5	0.72
BB55	59.5	0.73
BB60	64.5	0.79

Double Angle V-Belt

Part Number Example: **AA51** = **AA** **51**
Cross Section Inside Circumference (inches)

Part Number	Outside Circumference	Weight (lbs)
BB Section – Recommended Sheaves: Conventional – OD, Taper Bushed, or MST (B)		
BB64	68.5	0.86
BB68	72.5	0.89
BB71	75.5	0.95
BB72	76.5	0.96
BB73	77.5	0.97
BB74	78.5	0.98
BB75	79.5	1.00
BB76	80.5	1.01
BB77	81.5	1.02
BB78	82.5	1.04
BB80*	84.5	1.06
BB81	85.5	1.07
BB83	87.5	1.10
BB85	89.5	1.13
BB89	93.5	1.18
BB90	94.5	1.19
BB91*	95.5	1.20
BB92	96.5	1.22
BB93	97.5	1.23
BB94	98.5	1.24
BB95	99.5	1.25
BB96	100.5	1.27
BB97	101.5	1.28
BB100	104.5	1.32
BB103	107.5	1.36
BB105	109.5	1.38
BB107	111.5	1.41
BB108	112.5	1.42
BB111	115.5	1.46
BB112	116.5	1.47
BB116	120.5	1.52
BB117	121.5	1.53
BB118	122.5	1.55

Part Number	Outside Circumference	Weight (lbs)
BB Section – Recommended Sheaves: Conventional – OD, Taper Bushed, or MST (B)		
BB120	124.5	1.57
BB122	126.5	1.60
BB123	127.5	1.61
BB124	128.5	1.62
BB128	132.5	1.68
BB129	133.5	1.69
BB130	134.5	1.70
BB131*	135.5	1.71
BB136	140.5	1.78
BB140	144.5	1.84
BB144	148.5	1.89
BB155	159.5	2.03
BB157	161.5	2.06
BB158	162.5	2.07
BB160	164.5	2.10
BB162	166.5	2.12
BB168*	172.5	2.20
BB169*	173.5	2.21
BB170	174.5	2.23
BB173	177.5	2.26
BB180	184.5	2.35
BB182	186.5	2.38
BB190	194.5	2.48
BB195	199.5	2.55
BB210	214.5	2.72
BB225*	229.5	2.90
BB226*	230.5	2.91
BB228	232.5	2.94
BB230*	234.5	2.96
BB240*	244.5	3.09
BB255	259.5	3.28
BB267*	271.5	3.43
BB270	274.5	3.47

Heavy Duty V-Belts

Double Angle

V-Belt

Double Angle V-Belt Part Numbers

Part Number Example: **CC75** = **CC** **75**
Cross Section Inside Circumference (inches)

Part Number	Outside Circumference	Weight (lbs)
BB Section – Recommended Sheaves: Conventional – QD, Taper Bushed, or MST (B)		
BB273*	277.5	3.51
BB277*	281.5	3.56
BB278	282.5	3.58
BB285*	289.5	3.67
BB300	304.5	3.86
BB360*	364.5	4.69
CC Section – Recommended Sheaves: Conventional – QD, Taper Bushed, or MST (C)		
CC75*	81.4	1.84
CC81	87.4	1.97
CC85	91.4	2.07
CC90	96.4	2.18
CC96*	102.4	2.32
CC105	111.4	2.53
CC112	118.4	2.69
CC119*	125.4	2.85
CC120	126.4	2.87
CC128	134.4	3.06
CC136*	142.4	3.24
CC144	150.4	3.43
CC148*	154.4	3.54
CC150	156.4	3.59
CC158	164.4	3.75
CC162	168.4	3.84
CC173	179.4	4.10
CC176*	182.4	4.17
CC180	186.4	4.27
CC195	201.4	4.62
CC210	216.4	4.97
CC225	231.4	5.27
CC240	246.4	5.62
CC255*	261.4	5.97

Part Number	Outside Circumference	Weight (lbs)
CC Section – Recommended Sheaves: Conventional – QD, Taper Bushed, or MST (C)		
CC270	276.4	6.32
CC300	306.4	7.01
CC330*	336.4	7.70
CC360	366.4	8.44
CC390	396.4	9.14
CC420	426.4	9.84

*Non-stock item. Minimum order quantity and/or extended lead times may apply. Contact customer service for availability.

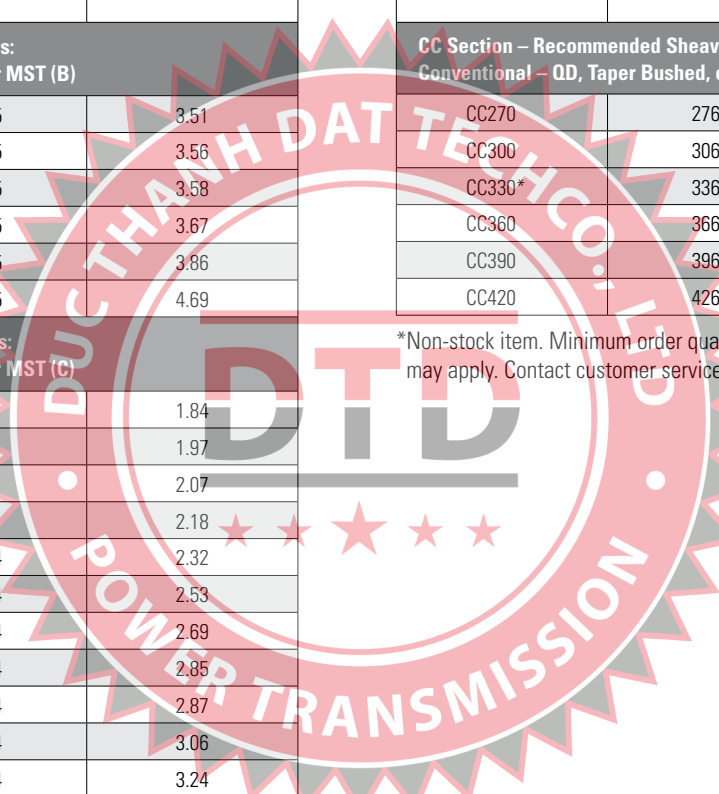

Vee-Rib™ V-Belt



1 Special, chemically treated polyester cord enhances belt stability.

2 Thin belt profile with smaller cord diameters for maximum flexibility at high speeds over small pulley diameters.

3 Molded rib construction yields better rib formation.

- Vibration-free
- Heat resistant
- Maximum flexibility
- High horsepower
- Abrasion resistant

Applications:
Industrial dryers
Fitness equipment
Machine tools
High speed blowers
& More

Heavy Duty V-Belts

Vee-Rib™

V-Belt

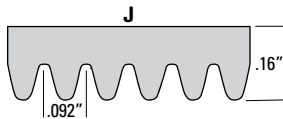

Vee-Rib™ Belts are ideally suited for high speed drives where conventional v-belts cannot operate.



Our Vee-Rib™ belt is ideally suited for high speed and high drive ratio applications that conventional v-belts just can't handle. The Carlisle® Vee-Rib belt by Timken offers smooth, vibration-free performance in a single, compact drive belt.

Vee-Rib belts allow the design of compact, vibration-free drives that are resistant to heat and abrasion for longer belt life.



Vee-Rib™ V-Belt Part Numbers

Part Number Example: **140J2** = **140** **J** **2**
Effective Length (inches in tenths: 14.0") Cross Section Number of Ribs

Part Number	Outside Circumference	Effective Length	Number of Ribs	Weight (lbs)
2-Rib				
140J2	14.5	14	2	0.01
150J2	15.5	15	2	0.01
160J2	16.5	16	2	0.02
170J2	17.5	17	2	0.02
180J2	18.5	18	2	0.02
190J2	19.5	19	2	0.02
200J2	20.5	20	2	0.02
210J2	21.5	21	2	0.02
220J2	22.5	22	2	0.02
230J2	23.5	23	2	0.02
240J2	24.5	24	2	0.02
260J2	26.5	26	2	0.03
280J2	28.5	28	2	0.03
290J2	29.5	29	2	0.03
300J2	30.5	30	2	0.03
310J2	31.5	31	2	0.03
320J2	32.5	32	2	0.03
330J2	33.5	33	2	0.03
340J2	34.5	34	2	0.03
350J2	35.5	35	2	0.03
360J2	36.5	36	2	0.03
370J2	37.5	37	2	0.04
380J2	38.5	38	2	0.04
390J2	39.5	39	2	0.04
400J2	40.5	40	2	0.04
410J2	41.5	41	2	0.04
420J2	42.5	42	2	0.04
430J2	43.5	43	2	0.04
440J2	44.5	44	2	0.04
450J2	45.5	45	2	0.04
460J2	46.5	46	2	0.04
490J2	49.5	49	2	0.05
520J2	52.5	52	2	0.05

Part Number	Outside Circumference	Effective Length	Number of Ribs	Weight (lbs)
2-Rib				
530J2	53.5	53	2	0.05
540J2	54.5	54	2	0.05
550J2	55.5	55	2	0.05
580J2	58.5	58	2	0.11
610J2	61.5	61	2	0.06
650J2	65.5	65	2	0.06
690J2	69.5	69	2	0.07
730J2	73.5	73	2	0.07
770J2	77.5	77	2	0.07
820J2	82.5	82	2	0.08
840J2	84.5	84	2	0.08
890J2	89.5	89	2	0.09
920J2	92.5	92	2	0.09
940J2	94.5	94	2	0.09
970J2	97.5	97	2	0.09
980J2	98.5	98	2	0.10
3-Rib				
140J3	14.5	14	3	0.02
150J3	15.5	15	3	0.02
160J3	16.5	16	3	0.02
170J3	17.5	17	3	0.02
180J3	18.5	18	3	0.03
190J3	19.5	19	3	0.03
200J3	20.5	20	3	0.03
210J3	21.5	21	3	0.03
220J3	22.5	22	3	0.03
230J3	23.5	23	3	0.03
240J3	24.5	24	3	0.03
260J3	26.5	26	3	0.04
280J3	28.5	28	3	0.04
290J3	29.5	29	3	0.04
300J3	30.5	30	3	0.04

Heavy Duty V-Belts

Vee-Rib™ V-Belt Part Numbers

Part Number	Outside Circumference	Effective Length	Number of Ribs	Weight (lbs)
3-Rib				
310J3	31.5	31	3	0.05
320J3	32.5	32	3	0.05
330J3	33.5	33	3	0.05
340J3	34.5	34	3	0.05
350J3	35.5	35	3	0.05
360J3	36.5	36	3	0.05
370J3	37.5	37	3	0.05
380J3	38.5	38	3	0.06
390J3	39.5	39	3	0.06
400J3	40.5	40	3	0.06
410J3	41.5	41	3	0.06
420J3	42.5	42	3	0.06
430J3	43.5	43	3	0.06
440J3	44.5	44	3	0.06
450J3	45.5	45	3	0.07
460J3	46.5	46	3	0.07
490J3	49.5	49	3	0.07
520J3	52.5	52	3	0.08
530J3	53.5	53	3	0.08
540J3	54.5	54	3	0.08
550J3	55.5	55	3	0.08
580J3	58.5	58	3	0.08
610J3	61.5	61	3	0.09
650J3	65.5	65	3	0.09
690J3	69.5	69	3	0.10
730J3	73.5	73	3	0.11
770J3	77.5	77	3	0.11
820J3	82.5	82	3	0.12
840J3	84.5	84	3	0.12
890J3	89.5	89	3	0.13
920J3	92.5	92	3	0.13
940J3	94.5	94	3	0.14
970J3	97.5	97	3	0.14

Part Number	Outside Circumference	Effective Length	Number of Ribs	Weight (lbs)
3-Rib				
980J3	98.5	98	3	0.14
4-Rib				
140J4	14.5	14	4	0.03
150J4	15.5	15	4	0.03
160J4	16.5	16	4	0.03
170J4	17.5	17	4	0.03
180J4	18.5	18	4	0.03
190J4	19.5	19	4	0.04
200J4	20.5	20	4	0.04
210J4	21.5	21	4	0.04
220J4	22.5	22	4	0.04
230J4	23.5	23	4	0.04
240J4	24.5	24	4	0.05
260J4	26.5	26	4	0.05
280J4	28.5	28	4	0.05
290J4	29.5	29	4	0.06
300J4	30.5	30	4	0.06
310J4	31.5	31	4	0.06
320J4	32.5	32	4	0.06
330J4	33.5	33	4	0.06
340J4	34.5	34	4	0.07
350J4	35.5	35	4	0.07
360J4	36.5	36	4	0.07
370J4	37.5	37	4	0.07
380J4	38.5	38	4	0.07
390J4	39.5	39	4	0.08
400J4	40.5	40	4	0.08
410J4	41.5	41	4	0.08
420J4	42.5	42	4	0.08
430J4	43.5	43	4	0.08
440J4	44.5	44	4	0.09
450J4	45.5	45	4	0.09

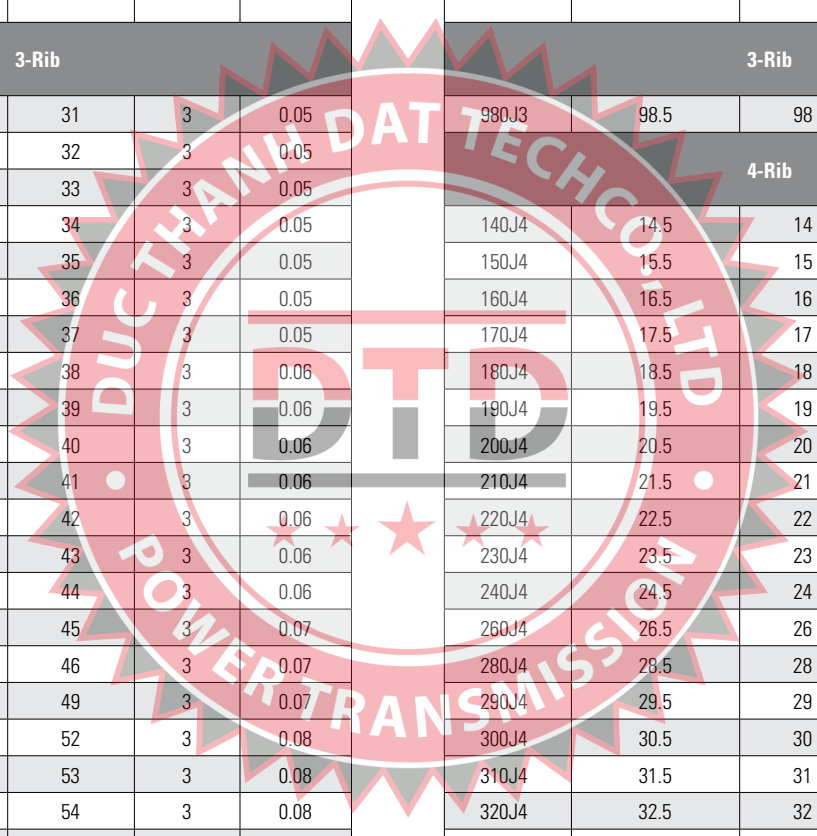

Vee-Rib™ V-Belt

Part Number Example: **440J4** = **440** **J** **4**
Effective Length (inches in tenths: 44.0") Cross Section Number of Ribs

Part Number	Outside Circumference	Effective Length	Number of Ribs	Weight (lbs)
4-Rib				
460J4	46.5	46	4	0.09
490J4	49.5	49	4	0.10
520J4	52.5	52	4	0.10
530J4	53.5	53	4	0.10
540J4	54.5	54	4	0.10
550J4	55.5	55	4	0.11
580J4	58.5	58	4	0.11
610J4	61.5	61	4	0.12
650J4	65.5	65	4	0.13
690J4	69.5	69	4	0.13
730J4	73.5	73	4	0.14
770J4	77.5	77	4	0.15
820J4	82.5	82	4	0.16
840J4	84.5	84	4	0.16
890J4	89.5	89	4	0.17
920J4	92.5	92	4	0.18
940J4	94.5	94	4	0.18
970J4	97.5	97	4	0.19
980J4	98.5	98	4	0.19
5-Rib				
140J5	14.5	14	5	0.03
150J5	15.5	15	5	0.04
160J5	16.5	16	5	0.04
170J5	17.5	17	5	0.04
180J5	18.5	18	5	0.04
190J5	19.5	19	5	0.05
200J5	20.5	20	5	0.05
210J5	21.5	21	5	0.05
220J5	22.5	22	5	0.05
230J5	23.5	23	5	0.06
240J5	24.5	24	5	0.06
260J5	26.5	26	5	0.06

Part Number	Outside Circumference	Effective Length	Number of Ribs	Weight (lbs)
5-Rib				
280J5	28.5	28	5	0.07
290J5	29.5	29	5	0.07
300J5	30.5	30	5	0.07
310J5	31.5	31	5	0.08
320J5	32.5	32	5	0.08
330J5	33.5	33	5	0.08
340J5	34.5	34	5	0.08
350J5	35.5	35	5	0.08
360J5	36.5	36	5	0.09
370J5	37.5	37	5	0.09
380J5	38.5	38	5	0.09
390J5	39.5	39	5	0.09
400J5	40.5	40	5	0.10
410J5	41.5	41	5	0.10
420J5	42.5	42	5	0.10
430J5	43.5	43	5	0.10
440J5	44.5	44	5	0.11
450J5	45.5	45	5	0.11
460J5	46.5	46	5	0.11
490J5	49.5	49	5	0.12
520J5	52.5	52	5	0.13
530J5	53.5	53	5	0.13
540J5	54.5	54	5	0.13
550J5	55.5	55	5	0.13
580J5	58.5	58	5	0.14
610J5	61.5	61	5	0.15
650J5	65.5	65	5	0.16
690J5	69.5	69	5	0.17
730J5	73.5	73	5	0.18
770J5	77.5	77	5	0.19
820J5	82.5	82	5	0.20
840J5	84.5	84	5	0.20
890J5	89.5	89	5	0.22

Heavy Duty V-Belts

Vee-Rib™ V-Belt Part Numbers

Part Number	Outside Circumference	Effective Length	Number of Ribs	Weight (lbs)
5-Rib				
920J5	92.5	92	5	0.22
940J5	94.5	94	5	0.23
970J5	97.5	97	5	0.24
980J5	98.5	98	5	0.24
6-Rib				
140J6	14.5	14	6	0.04
150J6	15.5	15	6	0.04
160J6	16.5	16	6	0.05
170J6	17.5	17	6	0.05
180J6	18.5	18	6	0.05
190J6	19.5	19	6	0.06
200J6	20.5	20	6	0.06
210J6	21.5	21	6	0.06
220J6	22.5	22	6	0.06
230J6	23.5	23	6	0.07
240J6	24.5	24	6	0.07
260J6	26.5	26	6	0.08
280J6	28.5	28	6	0.08
290J6	29.5	29	6	0.08
300J6	30.5	30	6	0.09
310J6	31.5	31	6	0.09
320J6	32.5	32	6	0.09
330J6	33.5	33	6	0.10
340J6	34.5	34	6	0.10
350J6	35.5	35	6	0.10
360J6	36.5	36	6	0.10
370J6	37.5	37	6	0.11
380J6	38.5	38	6	0.11
390J6	39.5	39	6	0.11
400J6	40.5	40	6	0.12
410J6	41.5	41	6	0.12
420J6	42.5	42	6	0.12

Part Number	Outside Circumference	Effective Length	Number of Ribs	Weight (lbs)
6-Rib				
430J6	43.5	43	6	0.13
440J6	44.5	44	6	0.13
450J6	45.5	45	6	0.13
460J6	46.5	46	6	0.13
490J6	49.5	49	6	0.14
520J6	52.5	52	6	0.15
530J6	53.5	53	6	0.15
540J6	54.5	54	6	0.16
550J6	55.5	55	6	0.16
580J6	58.5	58	6	0.17
610J6	61.5	61	6	0.18
650J6	65.5	65	6	0.19
690J6	69.5	69	6	0.20
730J6	73.5	73	6	0.21
770J6	77.5	77	6	0.22
820J6	82.5	82	6	0.24
840J6	84.5	84	6	0.24
890J6	89.5	89	6	0.26
920J6	92.5	92	6	0.27
940J6	94.5	94	6	0.27
970J6	97.5	97	6	0.28
980J6	98.5	98	6	0.29
8-Rib				
140J8	14.5	14	8	0.05
150J8	15.5	15	8	0.06
160J8	16.5	16	8	0.06
170J8	17.5	17	8	0.07
180J8	18.5	18	8	0.07
190J8	19.5	19	8	0.07
200J8	20.5	20	8	0.08
210J8	21.5	21	8	0.08
220J8	22.5	22	8	0.09

Vee-Rib™

V-Belt

Part Number Example: **240J8** = **240** **J** **8**
Effective Length (inches in tenths: 24.0") Cross Section Number of Ribs

Part Number	Outside Circumference	Effective Length	Number of Ribs	Weight (lbs)
8-Rib				
230J8	23.5	23	8	0.09
240J8	24.5	24	8	0.09
260J8	26.5	26	8	0.10
280J8	28.5	28	8	0.11
290J8	29.5	29	8	0.11
300J8	30.5	30	8	0.12
310J8	31.5	31	8	0.12
320J8	32.5	32	8	0.12
330J8	33.5	33	8	0.13
340J8	34.5	34	8	0.13
350J8	35.5	35	8	0.14
360J8	36.5	36	8	0.14
370J8	37.5	37	8	0.14
380J8	38.5	38	8	0.15
390J8	39.5	39	8	0.15
400J8	40.5	40	8	0.16
410J8	41.5	41	8	0.16
420J8	42.5	42	8	0.16
430J8	43.5	43	8	0.17
440J8	44.5	44	8	0.17
450J8	45.5	45	8	0.17
460J8	46.5	46	8	0.18
490J8	49.5	49	8	0.19
520J8	52.5	52	8	0.20
530J8	53.5	53	8	0.21
540J8	54.5	54	8	0.21
550J8	55.5	55	8	0.21
580J8	58.5	58	8	0.23
610J8	61.5	61	8	0.24
650J8	65.5	65	8	0.25
690J8	69.5	69	8	0.27
730J8	73.5	73	8	0.28
770J8	77.5	77	8	0.30

Part Number	Outside Circumference	Effective Length	Number of Ribs	Weight (lbs)
8-Rib				
820J8	82.5	82	8	0.32
840J8	84.5	84	8	0.33
890J8	89.5	89	8	0.35
920J8	92.5	92	8	0.36
940J8	94.5	94	8	0.36
970J8	97.5	97	8	0.38
980J8	98.5	98	8	0.38
10-Rib				
140J10	14.5	14	10	0.07
150J10	15.5	15	10	0.07
160J10	16.5	16	10	0.08
170J10	17.5	17	10	0.08
180J10	18.5	18	10	0.09
190J10	19.5	19	10	0.09
200J10	20.5	20	10	0.10
210J10	21.5	21	10	0.10
220J10	22.5	22	10	0.11
230J10	23.5	23	10	0.11
240J10	24.5	24	10	0.12
260J10	26.5	26	10	0.13
280J10	28.5	28	10	0.14
290J10	29.5	29	10	0.14
300J10	30.5	30	10	0.15
310J10	31.5	31	10	0.15
320J10	32.5	32	10	0.16
330J10	33.5	33	10	0.16
340J10	34.5	34	10	0.16
350J10	35.5	35	10	0.17
360J10	36.5	36	10	0.17
370J10	37.5	37	10	0.18
380J10	38.5	38	10	0.18
390J10	39.5	39	10	0.19

Heavy Duty V-Belts

Vee-Rib™ V-Belt Part Numbers

Part Number	Outside Circumference	Effective Length	Number of Ribs	Weight (lbs)	Part Number	Outside Circumference	Effective Length	Number of Ribs	Weight (lbs)
10-Rib					16-Rib				
400J10	40.5	40	10	0.19	210J16	21.5	21	16	0.16
410J10	41.5	41	10	0.20	220J16	22.5	22	16	0.17
420J10	42.5	42	10	0.20	230J16	23.5	23	16	0.18
430J10	43.5	43	10	0.21	240J16	24.5	24	16	0.19
440J10	44.5	44	10	0.21	260J16	26.5	26	16	0.20
450J10	45.5	45	10	0.22	280J16	28.5	28	16	0.22
460J10	46.5	46	10	0.22	290J16	29.5	29	16	0.23
490J10	49.5	49	10	0.24	300J16	30.5	30	16	0.23
520J10	52.5	52	10	0.25	310J16	31.5	31	16	0.24
530J10	53.5	53	10	0.26	320J16	32.5	32	16	0.25
540J10	54.5	54	10	0.26	330J16	33.5	33	16	0.26
550J10	55.5	55	10	0.27	340J16	34.5	34	16	0.26
580J10	58.5	58	10	0.28	350J16	35.5	35	16	0.27
610J10	61.5	61	10	0.30	360J16	36.5	36	16	0.28
650J10	65.5	65	10	0.32	370J16	37.5	37	16	0.29
690J10	69.5	69	10	0.33	380J16	38.5	38	16	0.29
730J10	73.5	73	10	0.35	390J16	39.5	39	16	0.30
770J10	77.5	77	10	0.37	400J16	40.5	40	16	0.31
820J10	82.5	82	10	0.40	410J16	41.5	41	16	0.32
840J10	84.5	84	10	0.41	420J16	42.5	42	16	0.33
920J10	92.5	92	10	0.45	430J16	43.5	43	16	0.33
940J10	94.5	94	10	0.46	440J16	44.5	44	16	0.34
970J10	97.5	97	10	0.47	450J16	45.5	45	16	0.35
980J10	98.5	98	10	0.48	460J16	46.5	46	16	0.36
16-Rib					490J16	49.5	49	16	0.38
140J16	14.5	14	16	0.11	520J16	52.5	52	16	0.40
150J16	15.5	15	16	0.12	530J16	53.5	53	16	0.41
160J16	16.5	16	16	0.12	540J16	54.5	54	16	0.42
170J16	17.5	17	16	0.13	550J16	55.5	55	16	0.43
180J16	18.5	18	16	0.14	580J16	58.5	58	16	0.45
190J16	19.5	19	16	0.15	610J16	61.5	61	16	0.47
200J16	20.5	20	16	0.16	650J16	65.5	65	16	0.50
					690J16	69.5	69	16	0.54

Vee-Rib™ V-Belt

Part Number Example: **840J16** = **840** **J** **16**
Effective Length (inches in tenths: 84.0") Cross Section Number of Ribs

Part Number	Outside Circumference	Effective Length	Number of Ribs	Weight (lbs)
16-Rib				
730J16	73.5	73	16	0.57
770J16	77.5	77	16	0.60
820J16	82.5	82	16	0.64
840J16	84.5	84	16	0.65
920J16	92.5	92	16	0.71
940J16	94.5	94	16	0.73
970J16	97.5	97	16	0.75
980J16	98.5	98	16	0.76
24-Rib				
140J24	14.5	14	24	0.16
150J24	15.5	15	24	0.17
160J24	16.5	16	24	0.19
170J24	17.5	17	24	0.20
180J24	18.5	18	24	0.21
190J24	19.5	19	24	0.22
200J24	20.5	20	24	0.23
210J24	21.5	21	24	0.24
220J24	22.5	22	24	0.26
230J24	23.5	23	24	0.27
240J24	24.5	24	24	0.28
260J24	26.5	26	24	0.30
280J24	28.5	28	24	0.33
290J24	29.5	29	24	0.34
300J24	30.5	30	24	0.35
310J24	31.5	31	24	0.36
320J24	32.5	32	24	0.37
330J24	33.5	33	24	0.38
340J24	34.5	34	24	0.40
350J24	35.5	35	24	0.41
360J24	36.5	36	24	0.42
370J24	37.5	37	24	0.43
380J24	38.5	38	24	0.44

Part Number	Outside Circumference	Effective Length	Number of Ribs	Weight (lbs)
24-Rib				
390J24	39.5	39	24	0.45
400J24	40.5	40	24	0.47
410J24	41.5	41	24	0.48
420J24	42.5	42	24	0.49
430J24	43.5	43	24	0.50
440J24	44.5	44	24	0.51
450J24	45.5	45	24	0.52
460J24	46.5	46	24	0.54
490J24	49.5	49	24	0.57
520J24	52.5	52	24	0.61
530J24	53.5	53	24	0.62
540J24	54.5	54	24	0.63
550J24	55.5	55	24	0.64
580J24	58.5	58	24	0.68
610J24	61.5	61	24	0.71
650J24	65.5	65	24	0.76
690J24	69.5	69	24	0.80
730J24	73.5	73	24	0.85
770J24	77.5	77	24	0.90
820J24	82.5	82	24	0.95
840J24	84.5	84	24	0.98
920J24	92.5	92	24	1.07
940J24	94.5	94	24	1.09
970J24	97.5	97	24	1.13
980J24	98.5	98	24	1.14
30-Rib				
140J30	14.5	14	30	0.20
150J30	15.5	15	30	0.22
160J30	16.5	16	30	0.23
170J30	17.5	17	30	0.25
180J30	18.5	18	30	0.26
190J30	19.5	19	30	0.28

Heavy Duty V-Belts

Vee-Rib® V-Belt Part Numbers

Part Number	Outside Circumference	Effective Length	Number of Ribs	Weight (lbs)
30-Rib				
200J30	20.5	20	30	0.29
210J30	21.5	21	30	0.31
220J30	22.5	22	30	0.32
230J30	23.5	23	30	0.33
240J30	24.5	24	30	0.35
260J30	26.5	26	30	0.38
280J30	28.5	28	30	0.41
290J30	29.5	29	30	0.42
300J30	30.5	30	30	0.44
310J30	31.5	31	30	0.45
320J30	32.5	32	30	0.47
330J30	33.5	33	30	0.48
340J30	34.5	34	30	0.49
350J30	35.5	35	30	0.51
360J30	36.5	36	30	0.52
370J30	37.5	37	30	0.54
380J30	38.5	38	30	0.55
390J30	39.5	39	30	0.57
400J30	40.5	40	30	0.58
410J30	41.5	41	30	0.60
420J30	42.5	42	30	0.61
430J30	43.5	43	30	0.63
440J30	44.5	44	30	0.64
450J30	45.5	45	30	0.65
460J30	46.5	46	30	0.67
490J30	49.5	49	30	0.71
520J30	52.5	52	30	0.76
530J30	53.5	53	30	0.77
540J30	54.5	54	30	0.79
550J30	55.5	55	30	0.80
580J30	58.5	58	30	0.84
610J30	61.5	61	30	0.89
650J30	65.5	65	30	0.95

Part Number	Outside Circumference	Effective Length	Number of Ribs	Weight (lbs)
30-Rib				
690J30	69.5	69	30	1.00
730J30	73.5	73	30	1.06
770J30	77.5	77	30	1.12
820J30	82.5	82	30	1.19
840J30	84.5	84	30	1.22
920J30	92.5	92	30	1.34
970J30	97.5	97	30	1.41
980J30	98.5	98	30	1.43

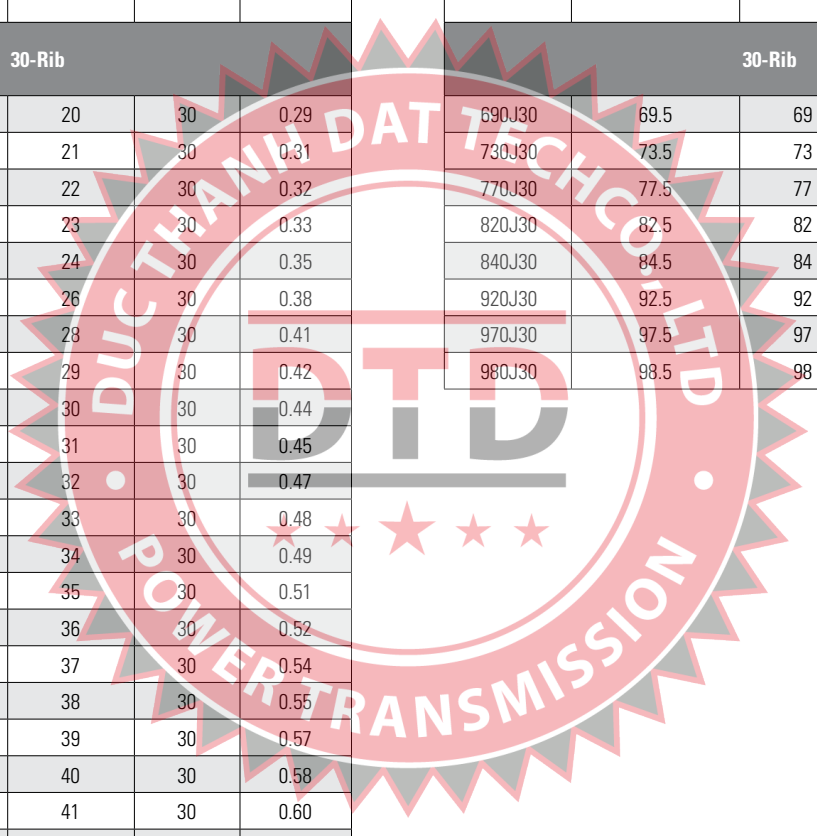

Vee-Rib™ J Sleeve Part Numbers

Part Number Example: **200J40** = **200** **J** **40**
Effective Length (inches in tenths: 20.0") Cross Section Number of Ribs

- Full factory width sleeves
- Sleeve edges are trimmed prior to shipment
- Sleeves cannot be returned
- All sleeve weights are approximate

Timken maintains inventory of most Carlisle® sleeve sizes. Non-stock sizes will be indicated by an asterisk following the part number. Contact customer service for availability.

Minimum order quantity and/or extended lead times may apply.

Occasional production inconsistencies which may render a portion of the sleeve unusable can be present as a normal part of the production process.

Each sleeve is inspected to ensure that it contains 90% or more usable product. A full width sleeve with less than 10% unusable product is considered acceptable.

Part Number	Sleeve Width Ribs	Weight (lbs)
J Sleeves (40-Rib)		
200J40*	40	0.39
210J40*	40	0.41
220J40*	40	0.43
230J40*	40	0.45
240J40*	40	0.47
260J40*	40	0.50
270J40*	40	0.52
280J40*	40	0.54
290J40*	40	0.56
300J40*	40	0.58
310J40*	40	0.60
320J40*	40	0.62
330J40*	40	0.64
340J40*	40	0.66
350J40*	40	0.68
360J40*	40	0.70
370J40*	40	0.72
380J40*	40	0.74
390J40*	40	0.76
400J40*	40	0.78
410J40*	40	0.80
420J40*	40	0.81

Part Number	Sleeve Width Ribs	Weight (lbs)
J Sleeves (40-Rib)		
430J40*	40	0.83
440J40*	40	0.85
450J40*	40	0.87
460J40*	40	0.89
470J40*	40	0.91
480J40*	40	0.93
490J40*	40	0.95
500J40*	40	0.97
520J40*	40	1.01
530J40*	40	1.03
540J40*	40	1.05
550J40*	40	1.07
580J40*	40	1.13
610J40*	40	1.18
650J40*	40	1.26
690J40*	40	1.34
730J40*	40	1.42
770J40*	40	1.49
840J40*	40	1.63
920J40*	40	1.78
980J40*	40	1.90

*Non-stock item. Minimum order quantity and/or extended lead times may apply. Contact customer service for availability.

Variable Speed Cog-Belt®

V-Belt



Variable Speed Cog-Belt®

V-Belt

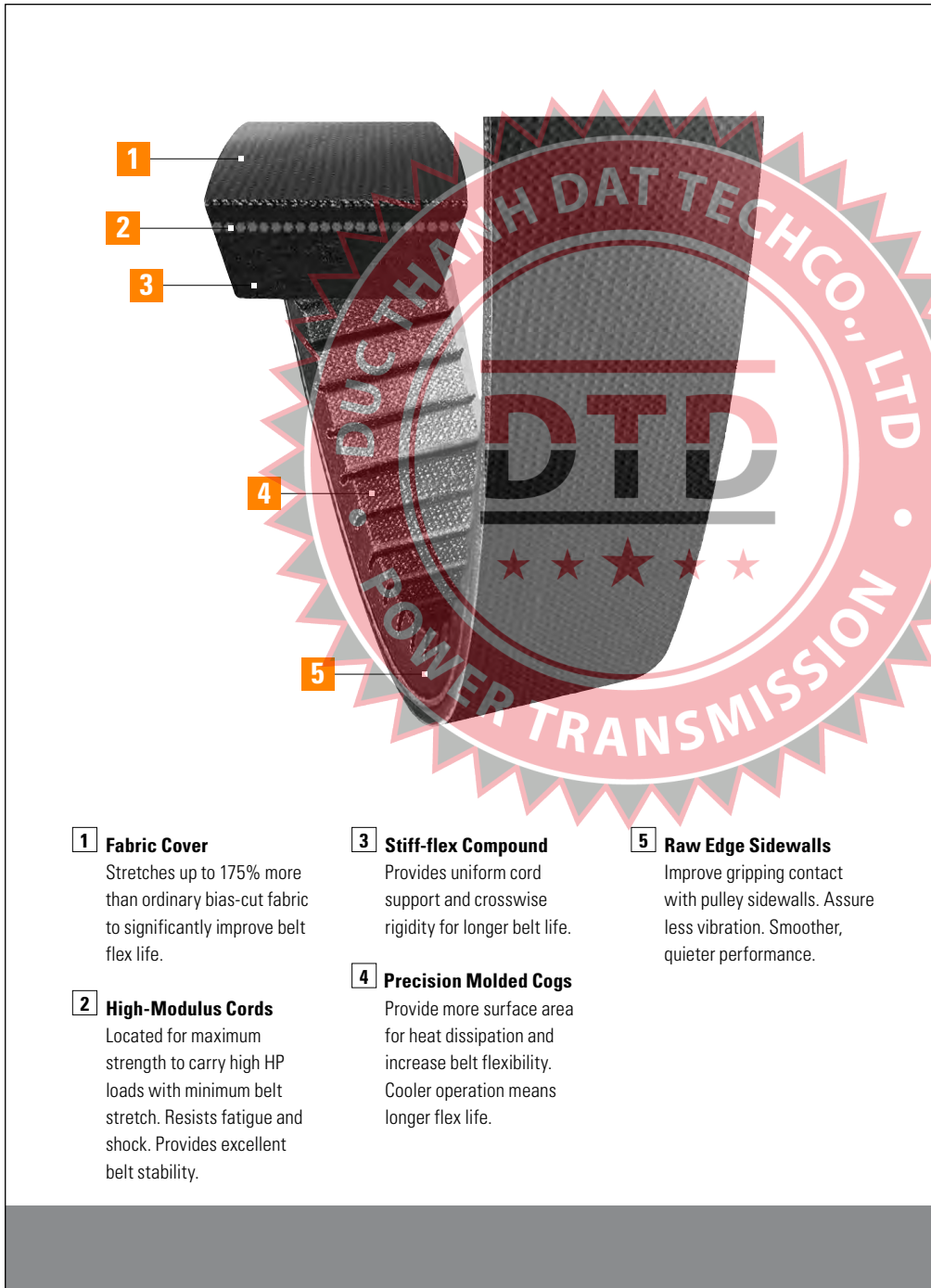

1 Fabric Cover

Stretches up to 175% more than ordinary bias-cut fabric to significantly improve belt flex life.

2 High-Modulus Cords

Located for maximum strength to carry high HP loads with minimum belt stretch. Resists fatigue and shock. Provides excellent belt stability.

3 Stiff-flex Compound

Provides uniform cord support and crosswise rigidity for longer belt life.

4 Precision Molded Cogs

Provide more surface area for heat dissipation and increase belt flexibility. Cooler operation means longer flex life.

5 Raw Edge Sidewalls

Improve gripping contact with pulley sidewalls. Assure less vibration. Smoother, quieter performance.

Smooth running

Oil and heat resistant

Long belt life

Wide selection of sizes

Applications:

Industrial variable speed drives & More

Heavy Duty V-Belts

Variable Speed Cog-Belt®

V-Belt

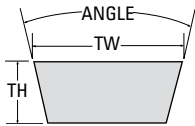

For use with variable speed pulleys to gain a wide range of driven speeds.



- The Variable Speed Cog-Belt® is designed for use in applications requiring exact speed control
- A replacement belt that's been engineered to the same high standards that Timken applies to belts produced for original equipment manufacturers (OEMs)
- Raw Edge sidewalls improve gripping action
- Unitized belt bonding and specially formulated rubber compounds provide superior resistance to aging caused by wear, oil, heat, grease and other harmful environmental factors
- Static dissipating

Variable Speed Cog-Belt® Part Numbers

Part Number	Top Width (in)	Outside Circumference	Weight (lbs)
1228V255	0.75	26.1	0.36
1422V240	0.91	24.6	0.30
1422V270	0.91	27.6	0.34
1422V290	0.91	29.6	0.36
1422V300	0.91	30.6	0.37
1422V330*	0.91	33.6	0.41
1422V340	0.91	34.6	0.43
1422V360	0.91	36.6	0.45
1422V400	0.91	40.6	0.50
1422V420	0.91	42.6	0.53
1422V440	0.91	44.6	0.56
1422V460*	0.91	46.6	0.58
1422V466*	0.91	47.2	0.59
1422V470*	0.91	47.6	0.59
1422V480	0.91	48.6	0.61
1422V540*	0.91	54.6	0.69
1422V600*	0.91	60.6	0.76
1422V660*	0.91	66.6	0.84
1422V720*	0.91	72.6	0.92
1422V780*	0.91	78.6	1.00
1430V215	0.92	21.9	0.25
1626V262*	1.06	26.8	0.43
1626V293*	1.06	29.9	0.48
1626V304	1.06	31.0	0.50
1626V330	1.06	33.6	0.54
1626V339*	1.06	34.5	0.56
1626V384	1.02	39.0	0.60
1626V428*	1.06	43.4	0.70
1626V440*	1.06	44.6	0.72
1626V513*	1.06	51.9	0.84
1626V517*	1.06	52.3	0.85
1626V604*	1.06	61.0	0.99
1626V700*	1.06	70.6	1.14

Variable Speed Cog-Belt®

V-Belt

Part Number Example: **1228V255** =

12 **28** **V** **255**
 Top Width Pulley Variable Pitch Length
 (inches in sixteenths: 12/16") Angle Speed (inches in tenths: 25.5")

Part Number	Top Width (in)	Outside Circumference	Weight (lbs)
1628V210*	1.00	21.2	0.23
1628V315*	1.00	32.0	0.48
1632V210*	1.00	21.5	0.24
1632V220*	1.00	22.5	0.26
1822V328*	1.13	33.4	0.59
1828V368*	1.13	37.5	0.83
1922V256*	1.19	26.2	0.49
1922V277*	1.19	28.3	0.53
1922V282*	1.19	28.8	0.54
1922V298	1.19	30.4	0.57
1922V302*	1.19	30.8	0.58
1922V321	1.19	32.7	0.61
1922V332	1.19	33.8	0.63
1922V338	1.19	34.4	0.64
1922V363	1.19	36.9	0.69
1922V381*	1.19	38.7	0.73
1922V386	1.19	39.2	0.73
1922V403	1.19	40.9	0.77
1922V417*	1.19	42.3	0.79
1922V426	1.19	43.2	0.81
1922V443	1.19	44.9	0.84
1922V454	1.19	46.0	0.86
1922V460	1.19	46.6	0.87
1922V484	1.19	49.0	0.92
1922V526	1.19	53.2	1.00
1922V544	1.19	55.0	1.03
1922V604	1.19	61.0	1.14
1922V630*	1.19	63.6	1.19
1922V646*	1.19	65.2	1.22
1922V666*	1.19	67.2	1.26
1922V686*	1.19	69.2	1.30
1922V706*	1.19	71.2	1.33
1922V726*	1.19	73.2	1.37

Part Number	Top Width (in)	Outside Circumference	Weight (lbs)
1922V751*	1.19	75.7	1.42
1922V756*	1.19	76.2	1.43
1922V806	1.19	81.2	1.52
1922V846	1.19	85.2	1.60
1922V891*	1.19	89.7	1.68
1922V966*	1.19	97.2	1.82
1926V250*	1.19	25.9	0.38
1926V275*	1.19	28.3	0.40
1926V390*	1.19	39.6	0.56
1930V366*	1.23	37.4	0.91
1930V375*	1.23	38.3	0.93
1930V400	1.23	40.8	1.00
1930V425*	1.23	43.3	1.06
1930V431*	1.23	43.9	1.07
1930V491	1.23	49.9	1.22
1930V530*	1.23	53.8	1.31
1930V541*	1.23	54.9	1.34
1930V591*	1.23	59.9	1.46
1930V600*	1.23	60.8	1.48
1930V641*	1.23	64.9	1.58
1930V691*	1.23	69.9	1.70
1930V750*	1.23	75.8	1.89
1930V791*	1.23	79.9	1.94
1930V891*	1.23	89.9	2.18
1930V991*	1.23	99.9	2.43
1930V1091*	1.23	109.9	2.67
1930V1191*	1.23	119.9	2.91
2126V309*	1.31	31.5	0.72
2126V468*	1.31	47.4	0.96
2226V307*	1.41	31.3	0.80
2230V266*	1.41	27.8	0.60
2230V275	1.41	28.5	0.61
2230V326	1.38	33.6	0.65

Heavy Duty V-Belts

Variable Speed Cog-Belt®

V-Belt

Variable Speed Cog-Belt® Part Numbers

Part Number	Top Width (in)	Outside Circumference	Weight (lbs)
2230V375*	1.38	38.4	0.60
2322V347	1.44	35.4	1.06
2322V364	1.44	37.1	1.11
2322V384*	1.44	39.1	1.17
2322V396	1.44	40.3	1.20
2322V421	1.44	42.8	1.27
2322V441	1.44	44.8	1.33
2322V481	1.44	48.8	1.45
2322V486*	1.44	49.3	1.47
2322V521	1.44	52.8	1.57
2322V541	1.44	54.8	1.63
2322V601	1.44	60.8	1.81
2322V621*	1.44	62.8	1.87
2322V661*	1.44	66.8	1.99
2322V681*	1.44	68.8	2.04
2322V701*	1.44	70.8	2.10
2322V721*	1.44	72.8	2.16
2322V801*	1.44	80.8	2.40
2322V826*	1.44	83.3	2.47
2322V846*	1.44	85.3	2.53
2322V886*	1.44	89.3	2.65
2322V921*	1.44	92.8	2.75
2322V1001*	1.44	100.8	2.99
2322V1061*	1.44	106.8	3.17
2326V310*	1.47	31.5	0.73
2326V359	1.44	36.6	1.08
2330V273*	1.44	28.0	0.56
2426V343	1.50	35.0	0.96
2428V707*	1.50	71.4	2.18
2430V297*	1.56	30.4	0.87
2430V345	1.56	35.2	1.01
2436V331*	1.56	33.8	0.95
2526V314*	1.56	32.0	0.91

Part Number	Top Width (in)	Outside Circumference	Weight (lbs)
2530V309*	1.64	31.6	0.95
2530V470*	1.63	48.1	2.07
2530V490	1.63	50.1	2.16
2530V530*	1.63	54.1	2.33
2530V550*	1.63	56.1	2.42
2530V575*	1.63	58.6	2.53
2530V595*	1.63	60.6	2.61
2530V610*	1.63	62.1	2.68
2530V630*	1.63	64.1	2.77
2530V660*	1.63	67.1	2.90
2530V670*	1.63	68.1	2.94
2530V690*	1.63	70.1	3.02
2530V700*	1.63	71.1	3.07
2530V730*	1.63	74.1	3.20
2530V740*	1.63	75.1	3.24
2530V750*	1.63	76.1	3.28
2530V790*	1.63	80.1	3.46
2530V840*	1.63	85.1	3.68
2530V890*	1.63	90.3	3.90
2530V934*	1.63	94.5	4.08
2530V990*	1.63	100.1	4.32
2530V1090*	1.63	110.1	4.75
2530V1190*	1.63	120.1	5.18
2530V1290*	1.63	130.1	5.62
2530V1490*	1.63	150.1	6.48
2530V1690*	1.63	170.1	7.35
2626V369*	1.66	37.6	1.15
2626V388	1.63	39.6	1.29
2630V345*	1.63	35.8	1.04
2636V332*	1.66	33.9	1.01
2822V778*	1.75	78.6	2.80
2826V412*	1.75	42.0	1.57
2826V452	1.75	46.0	1.62

Variable Speed Cog-Belt® V-Belt

Part Number Example: **2530V309** = **25** **30** **V** **309**
Top Width (inches in sixteenths: 25/16") Pulley Angle Variable Speed Pitch Length (inches in tenths: 30.9")

Part Number	Top Width (in)	Outside Circumference	Weight (lbs)
2830V337*	1.78	34.5	1.14
2830V363	1.78	37.0	1.23
2830V366*	1.78	37.2	1.23
2830V367	1.78	37.4	1.37
2830V393	1.78	40.0	1.33
2830V396*	1.78	40.5	1.34
2830V422	1.78	42.9	1.42
2830V428*	1.78	43.4	1.44
2836V343*	1.75	35.1	1.20
2836V361*	1.75	36.9	1.26
2836V380*	1.78	38.8	1.35
2926V366*	1.86	37.4	1.60
2926V400*	1.86	40.8	1.75
2926V426*	1.86	43.4	1.86
2926V471*	1.86	47.9	2.05
2926V477*	1.86	48.5	2.08
2926V486	1.86	49.6	2.12
2926V491*	1.86	50.1	2.15
2926V521	1.86	52.9	2.27
2926V546	1.86	56.1	2.40
2926V574*	1.86	58.2	2.49
2926V586*	1.86	59.4	2.54
2926V606	1.86	61.4	2.63
2926V616	1.86	62.6	2.68
2926V636*	1.86	64.4	2.76
2926V646*	1.86	65.4	2.80
2926V666*	1.86	67.4	2.88
2926V686	1.86	69.6	2.98
2926V706	1.86	71.4	3.05
2926V726	1.86	73.4	3.14
2926V776	1.86	78.4	3.35
2926V786*	1.86	79.4	3.40
2926V834*	1.86	84.2	3.60

Part Number	Top Width (in)	Outside Circumference	Weight (lbs)
2926V856*	1.86	86.4	3.70
2926V891*	1.86	89.9	3.84
2926V906	1.86	91.4	3.91
2926V966*	1.86	97.4	4.16
2926V1006*	1.86	101.4	4.34
3226V392	2.06	39.8	1.92
3226V395*	2.00	40.3	1.87
3226V400*	2.00	40.8	1.89
3226V439*	2.00	44.7	2.07
3226V450	2.06	46.7	2.64
3226V465*	2.00	47.3	2.19
3226V505	2.00	51.3	2.38
3226V514*	2.00	52.2	2.42
3226V545*	2.00	55.3	2.56
3226V585*	2.00	59.3	2.75
3226V603	2.00	61.1	2.83
3226V663*	2.00	67.1	3.11
3226V723	2.00	73.1	3.39
3226V783	2.00	79.1	3.66
3226V843*	2.00	85.1	3.94
3226V903	2.00	91.1	4.22
3226V963*	2.00	97.1	4.50
3226V1023*	2.00	103.1	4.77
3226V1083*	2.00	109.1	5.05
3230V419*	2.03	43.4	1.64
3230V560*	2.00	57.0	2.12
3230V710*	2.00	72.0	2.68
3230HV528*	2.05	53.9	3.00
3230HV553*	2.05	56.4	3.14
3230HV570*	2.05	58.1	3.24
3230HV585*	2.05	59.6	3.32
3230HV603*	2.05	61.4	3.42
3230HV613*	2.05	62.4	3.48

Heavy Duty V-Belts

Variable Speed Cog-Belt®

V-Belt

Variable Speed Cog-Belt® Part Numbers

Part Number	Top Width (in)	Outside Circumference	Weight (lbs)	Part Number	Top Width (in)	Outside Circumference	Weight (lbs)
3230HV620*	2.05	63.1	3.52	3836V734*	2.38	74.4	4.05
3230HV626*	2.05	63.7	3.55	3836V794*	2.38	80.4	4.38
3230HV644*	2.05	65.5	3.65	4030V538*	2.50	54.8	3.20
3230HV656*	2.05	66.7	3.72	4036V541	2.50	55.2	3.64
3230HV670*	2.05	68.1	3.79	4036V574*	2.56	58.4	3.46
3230HV685*	2.05	69.6	3.88	4230V556	2.63	56.8	3.54
3230HV702*	2.05	71.3	3.97	4230V605*	2.63	61.5	3.83
3230HV723	2.05	73.4	4.09	4230V653*	2.63	66.3	4.13
3230HV821	2.05	83.2	4.64	4430V510*	2.81	52.1	4.14
3230HV856*	2.05	86.7	4.83	4430V530*	2.81	54.1	4.30
3230HV931	2.05	94.2	5.25	4430V548*	2.81	55.9	4.44
3230HV960	2.05	97.1	5.41	4430V555*	2.81	56.6	4.50
3230HV1060	2.05	107.1	5.97	4430V570*	2.81	58.1	4.62
3236HV389*	2.00	40.2	2.12	4430V578*	2.81	58.9	4.68
3236V342*	2.00	35.2	1.30	4430V600*	2.81	61.1	4.85
3236V369*	2.00	37.9	1.69	4430V610	2.81	62.1	4.93
3236V432*	2.03	44.0	1.77	4430V630	2.81	64.1	5.09
3326V478*	2.09	48.7	2.53	4430V660	2.81	67.1	5.33
3432V450	2.19	45.6	2.02	4430V670	2.81	68.1	5.41
3432V456	2.19	46.4	2.06	4430V690	2.81	70.1	5.57
3432V480	2.19	48.6	2.15	4430V700	2.81	71.1	5.65
3432V484*	2.19	49.2	2.18	4430V718*	2.81	72.9	5.79
3432V534*	2.19	54.2	2.40	4430V730	2.81	74.1	5.89
3636V479*	2.25	48.7	2.49	4430V740*	2.81	75.1	5.97
3726V558*	2.34	56.7	3.14	4430V760*	2.81	77.1	6.13
3826V459*	2.38	46.9	2.10	4430V767	2.80	78.3	8.11
3826V465*	2.38	47.5	2.66	4430V790	2.81	80.1	6.36
3830V510	2.44	52.4	3.01	4430V850	2.81	86.1	6.84
3830V580*	2.44	59.0	3.50	4430V910	2.81	92.1	7.32
3830V587*	2.38	59.7	3.34	4430V970	2.81	98.1	7.80
3836V418*	2.38	42.8	2.32	4430V1030	2.81	104.1	8.27
3836V426*	2.38	43.6	2.37	4430V1090	2.81	110.1	8.75
3836V654*	2.38	66.4	3.62	4430V1150	2.81	116.1	9.23

Variable Speed Cog-Belt®

V-Belt

Part Number Example: **3836V734** = **38** **36** **V** **734**
Top Width (inches in sixteenths: 38/16") Pulley Angle Variable Speed Pitch Length (inches in tenths: 73.4")

Part Number	Top Width (in)	Outside Circumference	Weight (lbs)	Part Number	Top Width (in)	Outside Circumference	Weight (lbs)
4430V1320	2.81	133.1	10.58	4836V1120*	3.06	113.1	9.34
4430V1460	2.81	147.1	11.69	4836V1180*	3.00	119.1	10.43
4430V1610	2.81	162.1	12.89	4836V1250	3.06	126.1	10.41
4436V329*	2.80	34.0	1.79	5130V732	3.22	74.6	8.58
4436V525*	2.80	53.6	4.00	5130V799	3.19	81.2	9.23
4436V551*	2.80	56.2	4.20	5228V930*	3.28	93.8	11.00
4436V561*	2.80	57.2	4.10	5230V734	3.25	74.6	8.67
4436V576*	2.80	58.7	4.55	5230V867*	3.28	88.0	10.32
4436V646*	2.81	65.7	4.94	5430V783*	3.44	79.9	10.80
4626V596*	2.88	60.9	5.65	5636V750*	3.50	76.4	9.40
4630V650*	2.88	66.3	6.15	5636V774*	3.50	78.8	9.70
4630V663	2.91	67.4	6.93	5636V845*	3.50	85.9	1.10
4630V683*	2.88	69.2	6.43	5830V756*	3.63	77.0	10.02
4630V733*	2.88	74.3	7.50	6136V751*	3.84	76.4	10.49
4636V613*	2.88	62.6	5.63	6136V756	3.84	76.9	10.55
4830V602*	3.00	61.5	5.95				
4830V653*	3.00	66.4	6.45				
4830V699	3.00	71.2	6.95				
4830V750*	3.00	76.3	7.47				
4836V588*	3.00	59.9	4.50				
4836V608*	3.00	61.8	61.80				
4836V618*	3.06	62.9	4.81				
4836V642*	3.00	65.3	5.62				
4836V655	3.06	66.6	5.50				
4836V670*	3.00	68.1	5.87				
4836V710*	3.00	72.1	6.22				
4836V750*	3.06	76.1	6.29				
4836V800*	3.00	81.1	7.03				
4836V850*	3.00	86.1	7.48				
4836V900*	3.06	91.1	7.52				
4836V950*	3.06	96.1	7.94				
4836V1000*	3.06	101.1	8.35				
4836V1060*	3.06	107.1	8.85				

*Non-stock item. Minimum order quantity and/or extended lead times may apply. Contact customer service for availability.

Heavy Duty V-Belts

Gold-Ribbon® Cog-Band®

Banded Belt

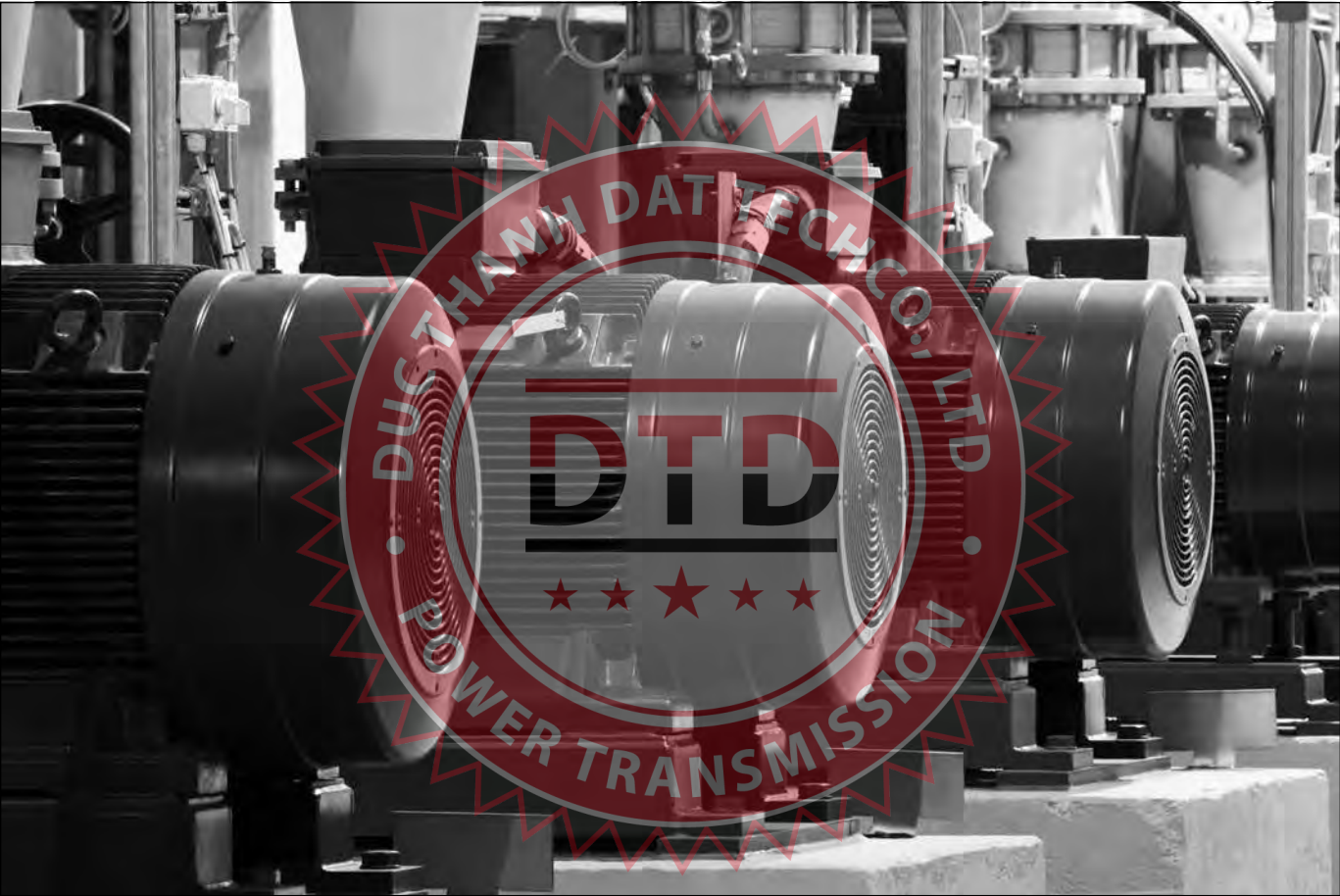

Gold-Ribbon® Cog-Band® Banded Belt

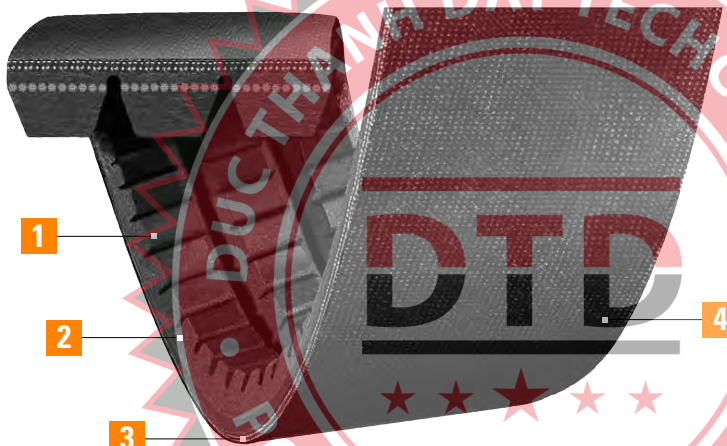

Eliminates belt
whip and turnover

50% longer belt life

Higher horsepower

Static dissipating

Applications:

Blowers
Fans
Pumps
& More

1 Precision Molded Cogs

Superior flexibility with reduced bending stress helps dissipate heat providing significantly longer belt life. Uses smaller pulley diameters. A cost and space saver.

2 Raw Edge Sidewalls

Produce a higher coefficient of friction. Keep a tighter grip on the pulley to reduce slippage. Improves performance and efficiency.

3 Double Ply Tie-Band

Two-layer highly engineered tie-band permanently bonds or "ties" multiple belts together. This assures smooth operation enabling the belts to function as a single unit, with even load distribution and wear. Vibration is dampened. Heavy shock loads are absorbed. Belt whip and turnover are eliminated.

4 Oil & Heat Resistant

Specially formulated chloroprene rubber compound protects against adverse environmental conditions.

Recommended Pulleys:

Conventional – OD, Taper Bushed, or MST (A-B, C, D)

Gold-Ribbon® Cog-Band®

Banded Belt

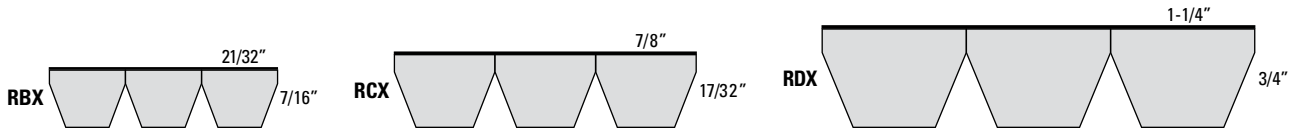

Prevents belt whip and rollover on long center distance drives.

This banded version of “The Energy Saver” combines the longer life and superior performance of the Gold-Ribbon® Cog-Belt® with the stability of a banded belt. Gold-Ribbon’s unique construction (combining the superior flexing of precision molded cogs with the tenacious gripping power of raw edge sidewalls) provides significantly longer belt life, higher efficiency and horsepower ratings, and opportunities to save time, energy and space.

An ideal choice for applications where increased horsepower or speed is required or when unusually severe shock loads are encountered.

The reinforced band across the top of two or more individual v-belts greatly enhances stability by eliminating belt whip and turnover. It prevents the belt from turning over or jumping off the drive.

For complete part number, add number of ribs required as indicated in example provided.

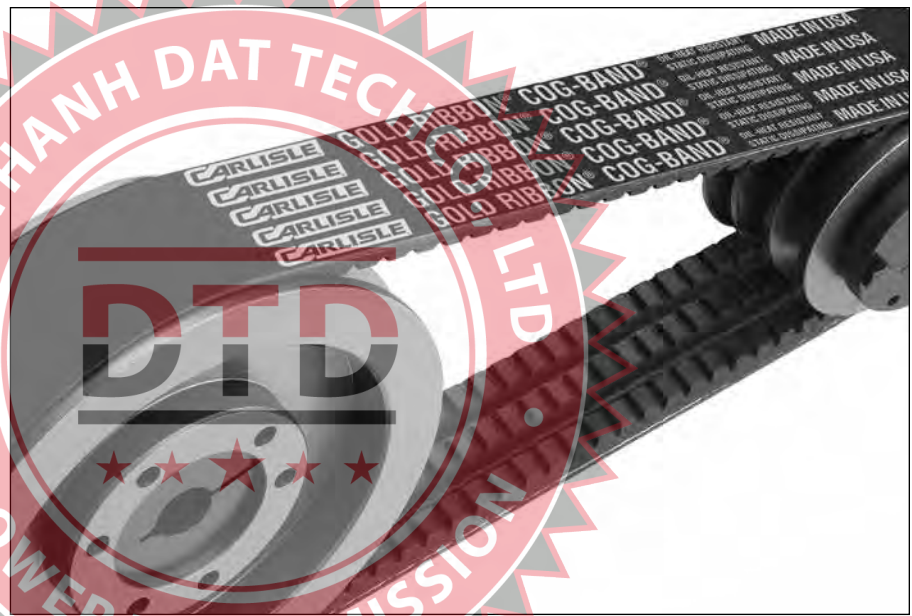

Horsepower Rating Comparison

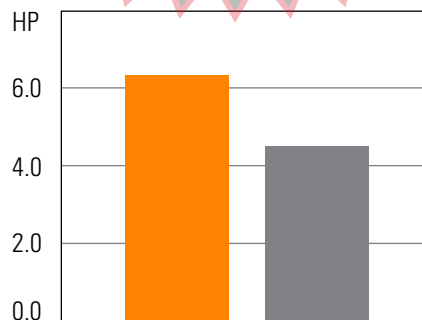

■ Gold-Ribbon Cog-Belt
■ Conventional Wrapped Belt

1500 RPM
1.5:1 Belt Drive Ratio

Energy Efficiency Comparison

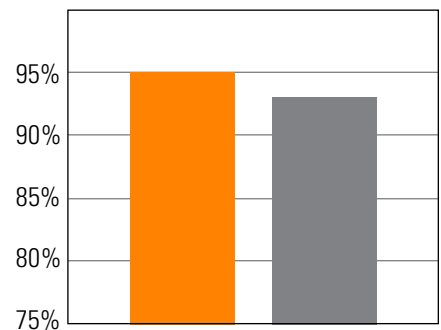

■ Gold-Ribbon Cog-Band
■ Conventional V-Band

Gold-Ribbon® Cog-Band® Banded Belt

Gold-Ribbon® Cog-Band® Banded Belt Part Numbers

Part Number Example: **RBX100-3** =

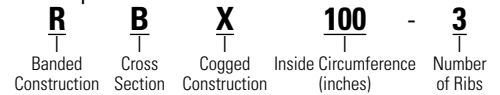

Part Number	Outside Circumference (in)	Weight Per Rib (lbs)
RBX – Banded BX Section; Recommended Pulleys: Conventional – QD, Taper Bushed, or MST (A-B)		
RBX51	54.9	0.63
RBX53	56.9	0.65
RBX55	58.9	0.68
RBX56	59.9	0.69
RBX58	61.9	0.71
RBX59	62.9	0.72
RBX60	63.9	0.74
RBX61	64.9	0.75
RBX62	65.9	0.76
RBX63	66.9	0.77
RBX64	67.9	0.78
RBX65	68.9	0.80
RBX66	69.9	0.81
RBX67	70.9	0.82
RBX68	71.9	0.83
RBX70	73.9	0.86
RBX71	74.9	0.87
RBX75	78.9	0.92
RBX77	80.9	0.94
RBX78	81.9	0.95
RBX79	82.9	0.97
RBX80	83.9	0.98
RBX81	84.9	0.99
RBX83	86.9	1.02
RBX85	88.9	1.04
RBX90	93.9	1.10
RBX93	96.9	1.14
RBX95	98.9	1.16
RBX97	100.9	1.19
RBX100	103.9	1.22
RBX102	105.9	1.25
RBX103	106.9	1.26
RBX105	108.9	1.28

Part Number	Outside Circumference (in)	Weight Per Rib (lbs)
RBX – Banded BX Section Recommended Pulleys: Conventional – QD, Taper Bushed, or MST (A-B)		
RBX108	111.9	1.32
RBX112	115.9	1.37
RBX116	119.9	1.42
RBX120	123.9	1.46
RBX128	131.9	1.56
RBX136	139.9	1.66
RBX144	147.9	1.76
RBX158	161.9	1.92
RBX173	176.9	2.10
RBX180	183.9	2.18
RBX195	198.9	2.36
RBL – Gold-Ribbon Band® – BL Section Recommended Pulleys: Conventional – QD, Taper Bushed, or MST (A-B)		
RBL210†	214.0	2.92
RBL240†	242.5	3.32
RBL270*†	272.5	3.73
RCX – Banded CX Section Recommended Pulleys: Conventional – QD, Taper Bushed, or MST (C)		
RCX68	72.9	1.38
RCX75	79.9	1.51
RCX75	79.9	1.51
RCX78	82.9	1.57
RCX81	85.9	1.63
RCX85	89.9	1.71
RCX90	94.9	1.80
RCX96	100.9	1.92
RCX105	109.9	2.10
RCX112	116.9	2.24
RCX120	124.9	2.40
RCX128	132.9	2.56
RCX131	135.9	2.62
RCX136	140.9	2.71
RCX137	141.9	2.73

Gold-Ribbon® Cog-Band®

Banded Belt

Gold-Ribbon® Cog-Band® Banded Belt Part Numbers

Part Number Example: **RCX190-3** =

R	C	X	190	-	3
Banded Construction	Cross Section	Cogged Construction	Inside Circumference (inches)		Number of Ribs

Part Number	Outside Circumference (in)	Weight Per Rib (lbs)
RCX – Banded CX Section Recommended Pulleys: Conventional – QD, Taper Bushed, or MST (C)		
RCX144	148.9	2.87
RCX158	162.9	3.15
RCX162	166.9	3.23
RCX173	177.9	3.45
RCX180	184.9	3.59
RCX190	194.9	3.78
RCX195	199.9	3.88
RCL – Gold-Ribbon Band† – CL Section Recommended Pulleys: Conventional – QD, Taper Bushed, or MST (C)		
RCL210†	215.3	4.78
RCL225†	228.3	5.07
RCL240*†	243.3	5.41
RCL255*†	258.3	5.74
RCL270*†	273.3	6.07
RCL300*†	303.3	6.74
RCL330*†	333.3	7.41
RDX – Banded DX Section Recommended Pulleys: Conventional – QD, Taper Bushed, or MST (D)		
RDX120*	124.9	5.80
RDX128*	132.9	6.10
RDX144*	148.9	6.90
RDX158*	162.9	7.50
RDX180*	184.9	8.50
RDX195*	199.9	9.30
RDL – Gold-Ribbon Band† – DL Section Recommended Pulleys: Conventional – QD, Taper Bushed, or MST (D)		
RDL210*†	213.9	8.99
RDL225*†	228.9	9.51
RDL240*†	243.9	10.14
RDL255†	258.9	10.77
RDL270*†	273.9	11.40
RDL300*†	303.9	12.66
RDL330*†	333.9	13.92

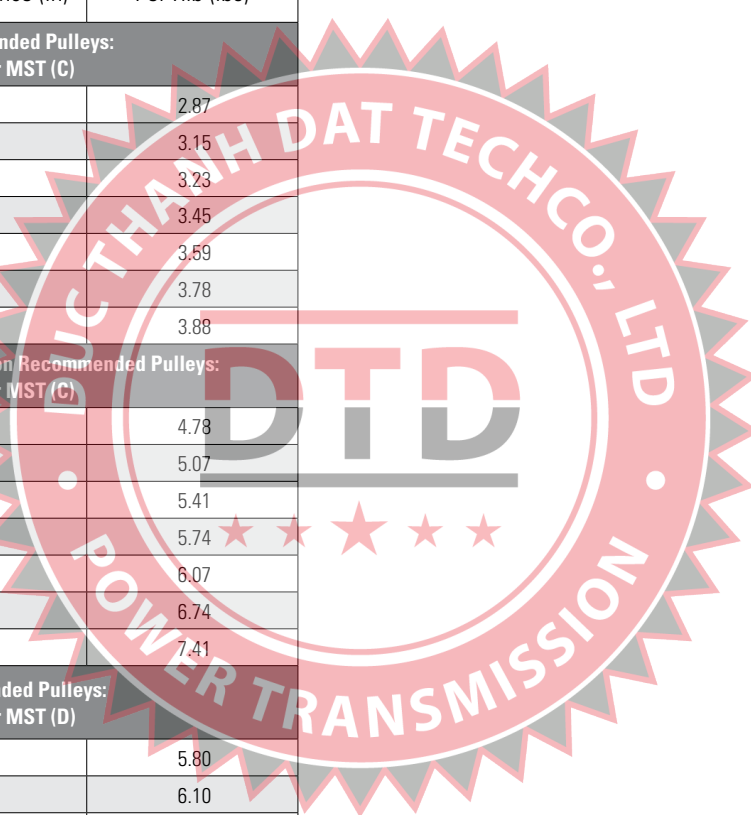

For complete part number, add number of ribs required as indicated in example above.

* Non-stock item. Minimum order quantity and/or extended lead times may apply. Contact customer service for availability.

† Gold-Ribbon Band uses laminated construction and replaces the Gold-Ribbon Cog-Band in the longer sizes (200" and above) only.

A matched set of Carlisle Gold-Ribbon Bands consists of 3 adjacent SAG numbers.

Power-Wedge® Cog-Band® Banded Belt

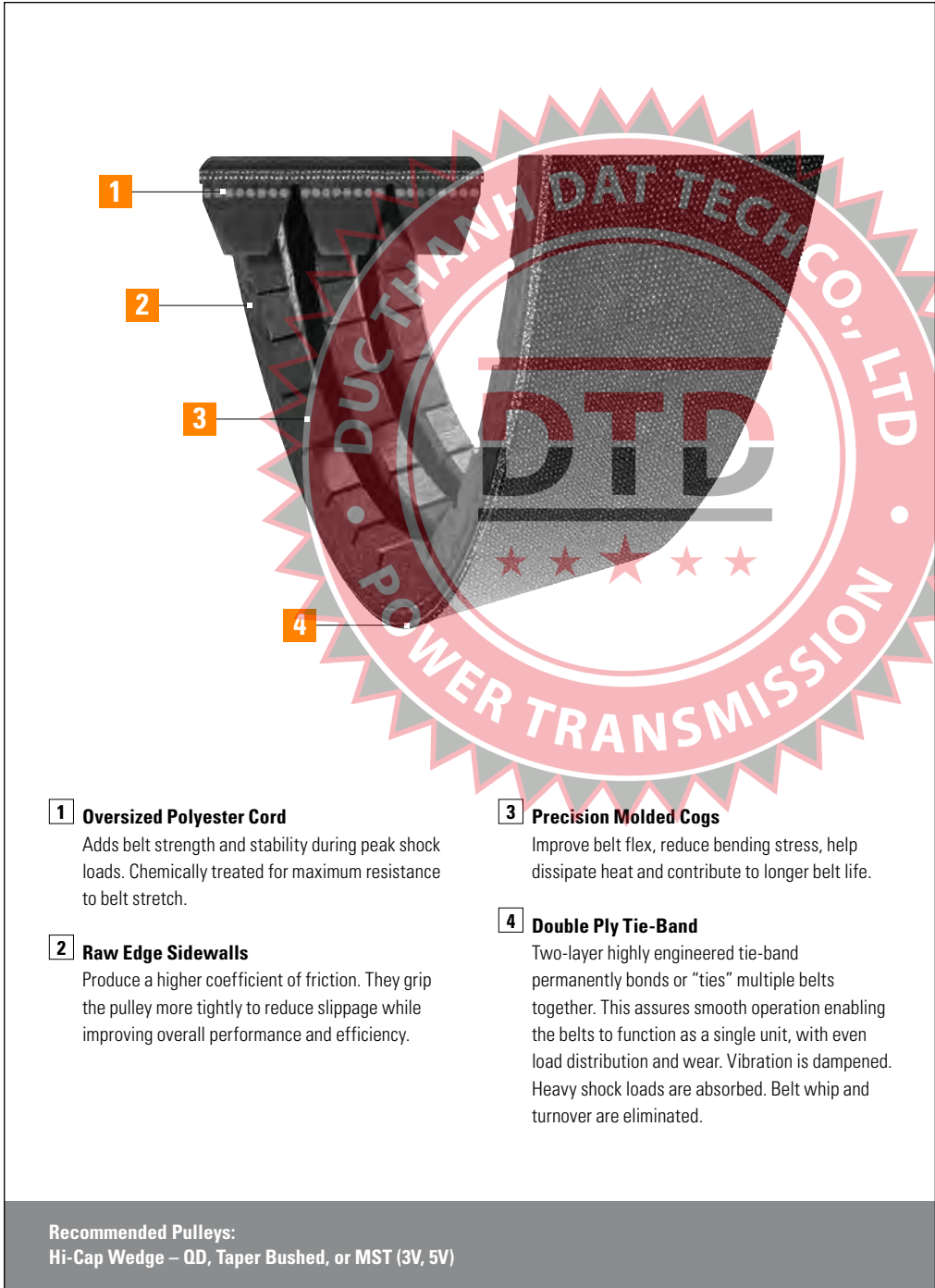

- Raw Edge construction
- Eliminates belt whip and turnover
- Higher horsepower
- Longer belt life
- Oil and heat resistant
- Static dissipating
- Applications:
 - Fans
 - Pumps
 - Compressors
 - & More

- 1 Oversized Polyester Cord**
Adds belt strength and stability during peak shock loads. Chemically treated for maximum resistance to belt stretch.
- 2 Raw Edge Sidewalls**
Produce a higher coefficient of friction. They grip the pulley more tightly to reduce slippage while improving overall performance and efficiency.

- 3 Precision Molded Cogs**
Improve belt flex, reduce bending stress, help dissipate heat and contribute to longer belt life.
- 4 Double Ply Tie-Band**
Two-layer highly engineered tie-band permanently bonds or “ties” multiple belts together. This assures smooth operation enabling the belts to function as a single unit, with even load distribution and wear. Vibration is dampened. Heavy shock loads are absorbed. Belt whip and turnover are eliminated.

Recommended Pulleys:
Hi-Cap Wedge – QD, Taper Bushed, or MST (3V, 5V)

Banded Belts

Power-Wedge® Cog-Band®

Banded Belt



Designed to minimize belt whip and turnover on the drive, the Power-Wedge® Cog-Band® provides outstanding resistance to oil, heat and harsh environments.

The Power-Wedge® Cog-Band® permanently bonds the individual elements together to assure pre-matched size and quality. Belt whip and turnover are eliminated. Vibration is dampened. Shock is absorbed.

The long life and performance of the cog-belt is combined with banded stability. The unique laminated construction combines the superior flexing of precision molded cogs with the gripping power of raw edge sidewalls. The result, a perfect balance of controlled transfer of power and slippage.

Recommended for applications requiring increased horsepower or speed, or where unusually severe shock loads are encountered.

For complete part number, add number of ribs required as indicated in example provided.



Horsepower Per Rib Comparison

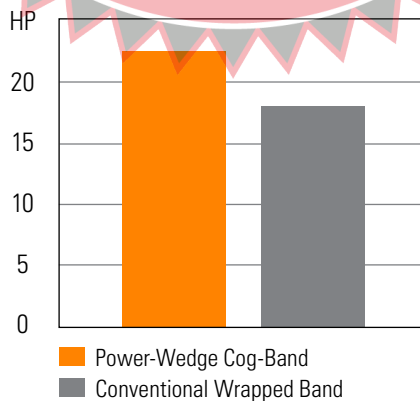

Power-Wedge® Cog-Band® Banded Belt

Power-Wedge® Cog-Band® Banded Belt Part Numbers

Part Number Example: **R5VX1000-3** =

R
Banded Construction
5V
Cross Section
X
Cogged Construction
1000
Effective Length (inches in tenths: 100.0)
-
3
Number of Ribs

Part Number	Outside Circumference (in)	Weight Per Rib (lbs)
R3VX – Banded 3VX Section Recommended Pulleys: Hi-Cap Wedge – QD, Taper Bushed, or MST (3V)		
R3VX250	26.1	0.13
R3VX265	27.6	0.14
R3VX280	29.1	0.15
R3VX300	31.1	0.16
R3VX315	32.6	0.16
R3VX335	34.6	0.17
R3VX355	36.6	0.18
R3VX375	38.6	0.19
R3VX400	40.8	0.20
R3VX425	43.3	0.21
R3VX450	45.8	0.22
R3VX475	48.3	0.24
R3VX500	50.8	0.25
R3VX530	53.8	0.26
R3VX560	56.8	0.28
R3VX600	60.8	0.30
R3VX630	63.8	0.32
R3VX670	67.8	0.34
R3VX710	71.8	0.36
R3VX750	75.8	0.38
R3VX800	80.8	0.40
R3VX850	85.8	0.43
R3VX900	90.8	0.45
R3VX950	95.8	0.48
R3VX1000	100.8	0.51
R3VX1060	106.8	0.54
R3VX1120	112.8	0.57
R3VX1180	118.8	0.60
R3VX1250	125.8	0.63
R3VX1320	132.8	0.67
R3VX1400	140.8	0.71

Part Number	Outside Circumference (in)	Weight Per Rib (lbs)
R5VX – Banded 5VX Section Recommended Pulleys: Hi-Cap Wedge – QD, Taper Bushed, or MST (5V)		
R5VX500	51.1	0.63
R5VX530	54.1	0.66
R5VX560	57.1	0.70
R5VX600	61.1	0.76
R5VX630	64.1	0.80
R5VX670	68.1	0.85
R5VX710	72.1	0.90
R5VX750	76.1	0.95
R5VX800	81.1	1.02
R5VX850	86.1	1.08
R5VX900	91.1	1.15
R5VX950	96.1	1.22
R5VX1000	101.1	1.28
R5VX1060	107.1	1.36
R5VX1120	113.1	1.44
R5VX1180	119.1	1.52
R5VX1250	126.1	1.61
R5VX1320	133.1	1.70
R5VX1400	141.1	1.80
R5VX1500	151.1	1.94
R5VX1600	161.1	2.07
R5VX1700	171.1	2.20
R5VX1800	181.1	2.33
R5VX1900	191.1	2.46
R5VX2000	201.1	2.59

For complete part number, add number of ribs required as indicated in example above.

Banded Belts

Wedge-Band[®]

Banded Belt

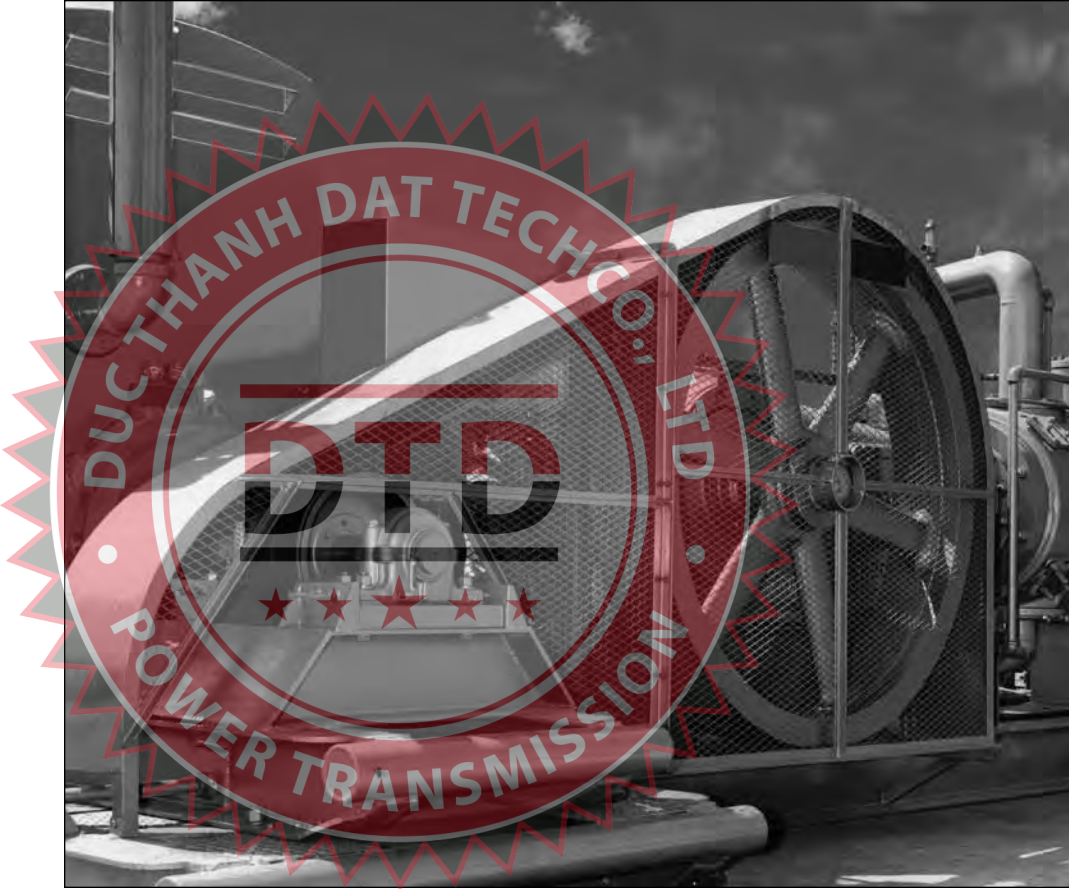

Wedge-Band® Banded Belt



1 Oversized Polyester Cord

Provides added belt strength and stability during peak shock loads. Cord is chemically treated for maximum resistance to belt stretch.

2 Double Ply Tie-Band

Two-layer highly engineered tie-band permanently bonds or “ties” multiple belts together. This assures smooth operation enabling the belts to function as a single unit, with even load distribution and wear. Vibration is dampened. Heavy shock loads are absorbed. Belt whip and turnover are eliminated.

- Wrapped construction
- Eliminates whip and turnover on narrow drives
- Smoother clutching
- Space and weight saver

Applications:
Mud pumps
Rock crushers
Stump grinders
& More

Recommended Pulleys:
Hi-Cap Wedge – QD, Taper Bushed, or MST (3V, 5V, 8V)

Wedge-Band®

Banded Belt

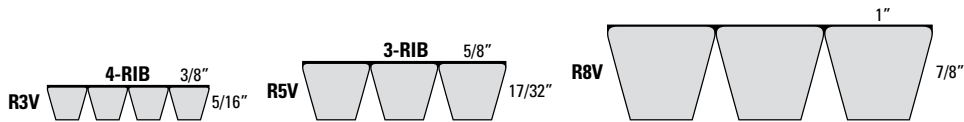

An excellent choice for narrow multiple drives where belt whip and turnover are a problem.

The Carlisle® Wedge-Band® by Timken is an excellent choice for virtually any application where increased horsepower capacity and output is needed, or where conventional multiple-belt drives are impractical because of space or weight limitations.

Wedge-Band is the banded version of the hard-working Carlisle Super Power-Wedge Belt.

The patented banding process assures smoother, quieter operation. Specially compounded wrapped construction is ideal for clutching operations. Wedge-Band is oil and heat resistant, static dissipating, and it won't turn over or jump off the drive.

For complete part number, add number of ribs required as indicated in example provided.

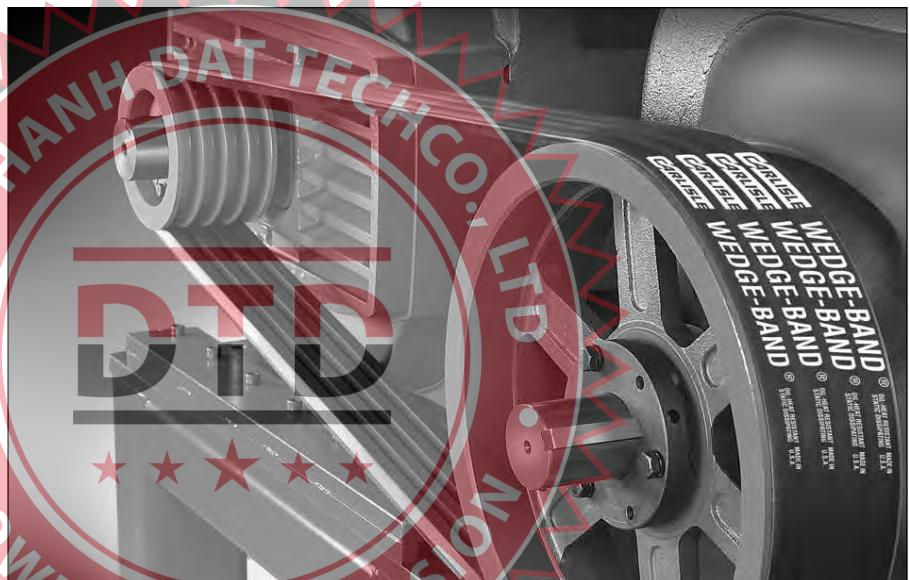

Wedge-Band® Banded Belt

Wedge-Band® Banded Belt Part Numbers

Part Number Example:

R5V670-3 = **R** **5V** **670** - **3**
Banded Construction Cross Section Effective Length (inches in tenths: 67.0) Number of Ribs

Part Number	Outside Circumference (in)	Weight Per Rib (lbs)
R3V – Banded 3V Section Recommended Pulleys: Hi-Cap Wedge – QD, Taper Bushed, or MST (3V)		
R3V335*	34.6	0.20
R3V355	36.6	0.21
R3V375	38.6	0.22
R3V400	41.1	0.23
R3V425*	43.6	0.25
R3V450	46.1	0.26
R3V475	48.6	0.28
R3V500	51.1	0.29
R3V530	54.1	0.31
R3V560	57.1	0.33
R3V600	61.1	0.35
R3V630	64.1	0.37
R3V670	68.1	0.39
R3V710	72.1	0.42
R3V750	76.1	0.44
R3V800	81.1	0.47
R3V850	86.1	0.50
R3V900	91.1	0.53
R3V950	96.1	0.53
R3V1000	101.1	0.56
R3V1060	107.1	0.59
R3V1120	113.1	0.63
R3V1180	119.1	0.66
R3V1250	126.1	0.70
R3V1320	133.1	0.74
R3V1400	141.1	0.79
R5V – Banded 5V Section Recommended Pulleys: Hi-Cap Wedge – QD, Taper Bushed, or MST (5V)		
R5V500*	51.1	0.68
R5V530*	54.1	0.73
R5V560	57.1	0.77
R5V600	61.1	0.82
R5V630	64.1	0.86

Part Number	Outside Circumference (in)	Weight Per Rib (lbs)
R5V – Banded 5V Section Recommended Pulleys: Hi-Cap Wedge – QD, Taper Bushed, or MST (5V)		
R5V670	68.1	0.92
R5V710	72.1	0.97
R5V750	76.1	1.03
R5V800	81.1	1.10
R5V850	86.1	1.17
R5V900	91.1	1.24
R5V950	96.1	1.31
R5V1000	101.1	1.38
R5V1060	107.1	1.46
R5V1120	113.1	1.54
R5V1180	119.1	1.63
R5V1250	126.1	1.73
R5V1320	133.1	1.82
R5V1400	141.1	1.93
R5V1500	151.1	2.07
R5V1600	161.1	2.21
R5V1700	171.1	2.35
R5V1800	181.1	2.49
R5V1800	181.1	2.49
R5V1900	191.1	2.63
R5V2000	201.1	2.76
R5V2120	213.1	2.93
R5V2240	225.1	3.10
R5V2360	237.1	3.26
R5V2500	251.1	3.46
R5V2650	266.1	3.67
R5V2800	281.1	3.87
R5V3000	301.1	4.15
R5V3150	316.1	4.36
R5V3350	336.1	4.64
R5V3550	356.1	4.91

Banded Belts

Wedge-Band®

Banded Belt

Wedge-Band® Banded Belt Part Numbers

Part Number Example:

R8V1000-3 = **R** **8V** **1000** - **3**
Banded Construction Cross Section Effective Length (inches in tenths: 100.0) Number of Ribs

Part Number	Outside Circumference (in)	Weight Per Rib (lbs)
R8V – Banded 8V Section Recommended Pulleys: Hi-Cap Wedge – QD, Taper Bushed, or MST (8V)		
R8V1000	101.1	3.57
R8V1060	107.1	3.78
R8V1120	113.1	4.01
R8V1180	119.1	4.22
R8V1250	126.1	4.48
R8V1320	133.1	4.73
R8V1400	141.1	5.02
R8V1500	151.1	5.39
R8V1600	161.1	5.75
R8V1700	171.1	6.11
R8V1800	181.1	6.47
R8V1900	191.1	6.84
R8V2000	201.1	7.20
R8V2120	213.1	7.63
R8V2240	225.1	8.07
R8V2360	237.1	8.51
R8V2500	251.1	9.01
R8V2650	266.1	9.56
R8V2800	281.1	10.11
R8V3000	301.1	10.83
R8V3150	316.1	11.38
R8V3350	336.1	12.11
R8V3550	356.1	12.83
R8V3750	376.1	14.06
R8V4000	401.1	15.00
R8V4250	426.1	15.94
R8V4500	451.1	16.88
R8V4750*	476.1	17.83
R8V5000*	501.1	18.76
R8V5600*	561.1	21.03
R8V6000*	601.1	22.53
R8V6600*	661.1	24.80

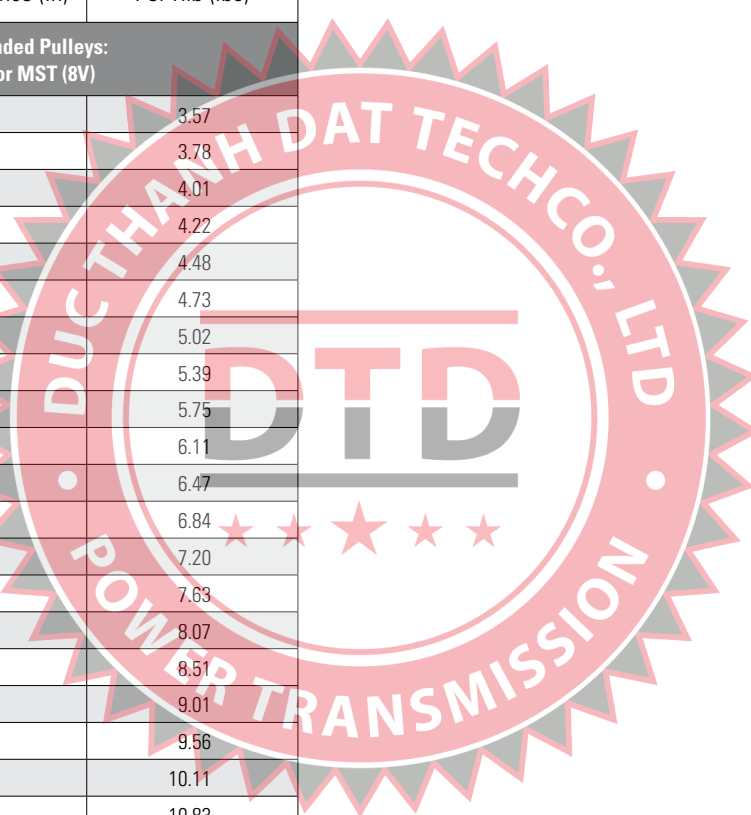

For complete part number, add number of ribs required as indicated in example above.

* Non-stock item. Minimum order quantity and/or extended lead times may apply. Contact customer service for availability.

Aramax[®] Wedge-Band[®] Banded Belt

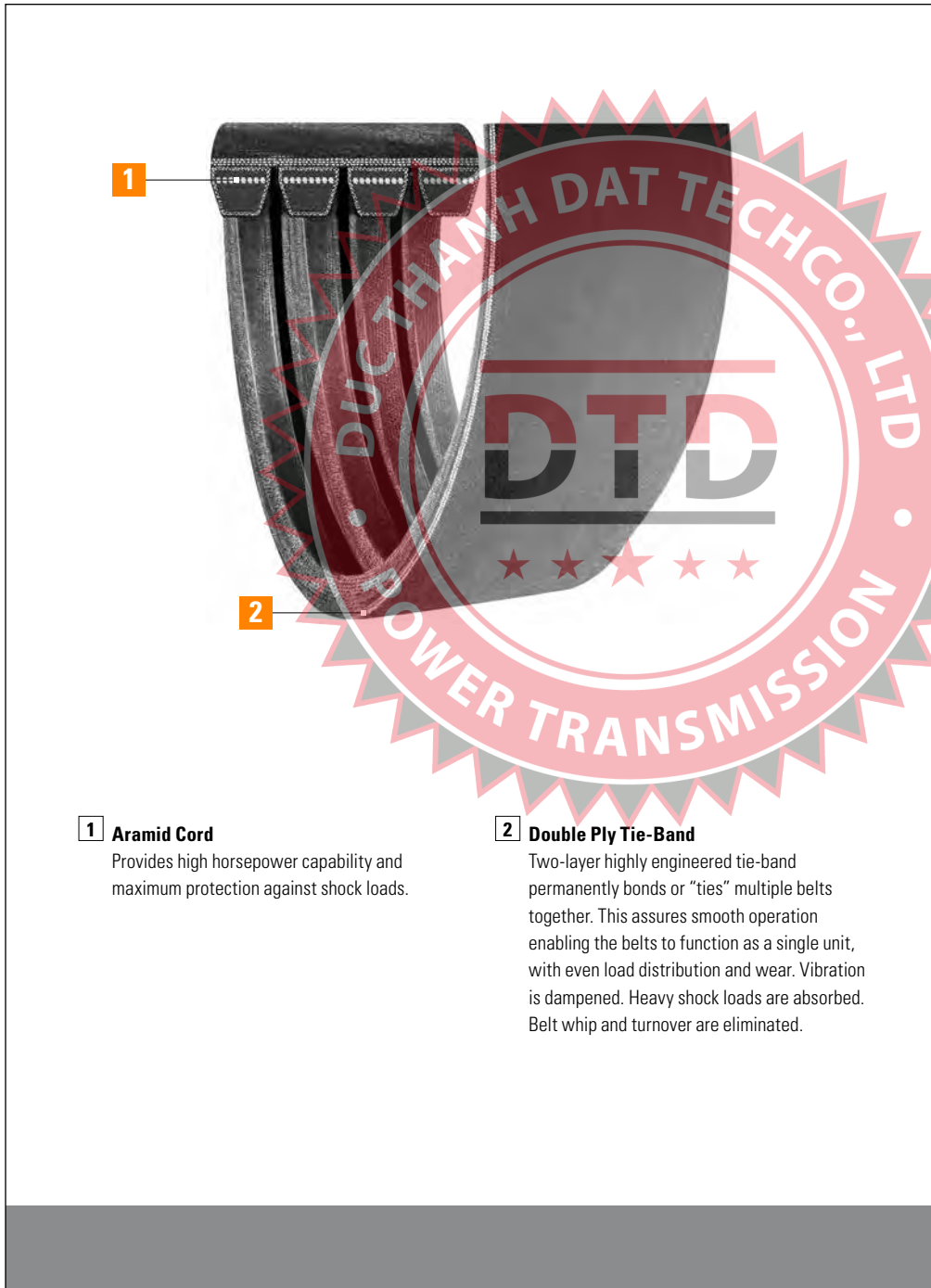

1 Aramid Cord

Provides high horsepower capability and maximum protection against shock loads.

2 Double Ply Tie-Band

Two-layer highly engineered tie-band permanently bonds or "ties" multiple belts together. This assures smooth operation enabling the belts to function as a single unit, with even load distribution and wear. Vibration is dampened. Heavy shock loads are absorbed. Belt whip and turnover are eliminated.

Super high performance banded belt

Tough aramid cord construction

Excels in harsh oil field and industrial applications

Applications:
Oil field mud pumps & More

Aramax® Wedge-Band®

Banded Belt

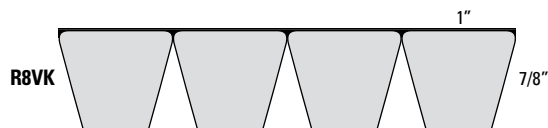

The Aramax® Wedge-Band® is designed for extraordinary banded belt strength on the toughest belt drives.

The Aramax® Wedge-Band® is ideally suited for oil field equipment, rock and quarry applications, forestry industry applications and heavy construction machinery. Aramid cord provides maximum protection against belt breakage due to shock loads.

Because of the high horsepower loads involved, standard 8V cast iron Q-D® pulleys typically DO NOT have sufficient horsepower capacity to operate with the Aramax Wedge-Band at the belt's rated horsepower. As a result, special pulleys are frequently required as well.

Due to the unique nature of these "super high performance" banded belts, no drive design literature is available. Rather, we strongly suggest that you work with our application engineering department for design assistance. This assures a safe and satisfactory drive.

Note: When these R8VK belts are used as a matched set, all belts in the set must have the same sag number. These high modulus aramid cord belts require closer matching than standard R8V belts in order to tension properly as a set.

Aramax® Wedge-Band® Banded Belt Part Numbers

Part Number	Number of Ribs	Outside Circumference (in)	Weight (lbs)
R8V Cross Section			
R8VK1500-4*	4	151.1	21.41
R8VK1500-5*	5	151.1	26.76
R8VK1500-6*	6	151.1	32.11
R8VK1500-8*	8	151.1	42.81
R8VK1500-10*	10	151.1	53.51
R8VK1500-12*	12	151.1	64.22
R8VK1600-4*	4	161.1	22.87
R8VK1600-5*	5	161.1	28.58
R8VK1600-6*	6	161.1	34.30
R8VK1600-8*	8	161.1	45.73
R8VK1600-10*	10	161.1	57.17
R8VK1600-12*	12	161.1	68.60
R8VK1700-4*	4	171.1	24.31
R8VK1700-5*	5	171.1	30.39
R8VK1700-6*	6	171.1	36.46
R8VK1700-8*	8	171.1	48.62
R8VK1700-10*	10	171.1	60.77
R8VK1700-12*	12	171.1	72.93
R8VK1800-4	4	181.1	25.75
R8VK1800-5	5	181.1	32.19
R8VK1800-6	6	181.1	38.63
R8VK1800-8	8	181.1	51.50
R8VK1800-10	10	181.1	64.38
R8VK1800-12	12	181.1	77.25
R8VK1900-4	4	191.1	27.21
R8VK1900-5	5	191.1	34.02
R8VK1900-6	6	191.1	40.82
R8VK1900-8	8	191.1	54.42
R8VK1900-10	10	191.1	68.03
R8VK1900-12	12	191.1	81.64
R8VK2000-4	4	201.1	28.65
R8VK2000-5	5	201.1	35.82
R8VK2000-6	6	201.1	42.98

Q-D® is a registered trademark of Regal Beloit America, Inc.

Aramax® Wedge-Band® Banded Belt

Part Number Example: **R8VK1500-4** = **R** **8V** **K** **1500** - **4**
Banded Construction Cross Section Aramid Cord Construction Effective Length (inches in tenths: 150.0) Number of Ribs

Part Number	Number of Ribs	Outside Circumference (in)	Weight (lbs)
R8V Cross Section			
R8VK2000-8	8	201.1	57.31
R8VK2000-10	10	201.1	71.63
R8VK2000-12	12	201.1	85.96
R8VK2120-4	4	213.1	30.38
R8VK2120-5	5	213.1	37.98
R8VK2120-6	6	213.1	45.58
R8VK2120-8	8	213.1	60.77
R8VK2120-10	10	213.1	75.96
R8VK2120-12	12	213.1	91.15
R8VK2240-4	4	225.1	32.13
R8VK2240-5	5	225.1	40.17
R8VK2240-6	6	225.1	48.20
R8VK2240-8	8	225.1	64.27
R8VK2240-10	10	225.1	80.33
R8VK2240-12	12	225.1	96.40
R8VK2360-4	4	237.1	33.86
R8VK2360-5	5	237.1	42.33
R8VK2360-6	6	237.1	50.80
R8VK2360-8	8	237.1	67.73
R8VK2360-10	10	237.1	84.66
R8VK2360-12	12	237.1	101.59
R8VK2500-4	4	251.1	35.88
R8VK2500-5	5	251.1	44.85
R8VK2500-6	6	251.1	53.82
R8VK2500-8	8	251.1	71.76
R8VK2500-10	10	251.1	89.71
R8VK2500-12	12	251.1	107.65
R8VK2650-4	4	266.1	38.05
R8VK2650-5	5	266.1	47.57
R8VK2650-6	6	266.1	57.08
R8VK2650-8	8	266.1	76.11
R8VK2650-10	10	266.1	95.14
R8VK2650-12	12	266.1	114.16

Part Number	Number of Ribs	Outside Circumference (in)	Weight (lbs)
R8V Cross Section			
R8VK2800-4	4	281.1	40.23
R8VK2800-5	5	281.1	50.28
R8VK2800-6	6	281.1	60.34
R8VK2800-8	8	281.1	80.45
R8VK2800-10	10	281.1	100.57
R8VK2800-12	12	281.1	120.68
R8VK3000-4	4	301.1	43.13
R8VK3000-5	5	301.1	53.91
R8VK3000-6	6	301.1	64.70
R8VK3000-8	8	301.1	86.26
R8VK3000-10	10	301.1	107.83
R8VK3000-12	12	301.1	129.39
R8VK3150-4	4	316.1	45.30
R8VK3150-5	5	316.1	56.63
R8VK3150-6	6	316.1	67.95
R8VK3150-8	8	316.1	90.61
R8VK3150-10	10	316.1	113.26
R8VK3150-12	12	316.1	135.91
R8VK3350-4	4	336.1	48.19
R8VK3350-5	5	336.1	60.23
R8VK3350-6	6	336.1	72.28
R8VK3350-8	8	336.1	96.37
R8VK3350-10	10	336.1	120.47
R8VK3350-12	12	336.1	144.56
R8VK3550-4	4	356.1	51.09
R8VK3550-5	5	356.1	63.86
R8VK3550-6	6	356.1	76.63
R8VK3550-8	8	356.1	102.18
R8VK3550-10	10	356.1	127.72
R8VK3550-12	12	356.1	153.27
R8VK3750-4	4	376.1	53.97
R8VK3750-5	5	376.1	67.47
R8VK3750-6	6	376.1	80.96

Aramax® Wedge-Band® Banded Belt

Aramax® Wedge-Band® Banded Belt Part Numbers

Part Number Example: **R8VK3350-4** =

R	8V	K	3350	-	4
Banded Construction	Cross Section	Aramid Cord Construction	Effective Length (inches in tenths: 335.0)		Number of Ribs

Part Number	Number of Ribs	Outside Circumference (in)	Weight (lbs)
R8V Cross Section			
R8VK3750-8	8	376.1	107.95
R8VK3750-10	10	376.1	134.93
R8VK3750-12	12	376.1	161.92
R8VK4000-4*	4	401.1	57.12
R8VK4000-5*	5	401.1	71.40
R8VK4000-6*	6	401.1	85.68
R8VK4000-8*	8	401.1	114.24
R8VK4000-10*	10	401.1	142.80
R8VK4000-12*	12	401.1	171.36
R8VK4250-4*	4	426.1	59.92
R8VK4250-5*	5	426.1	74.90
R8VK4250-6*	6	426.1	89.88
R8VK4250-8*	8	426.1	119.84
R8VK4250-10*	10	426.1	149.80
R8VK4250-12*	12	426.1	179.76
R8VK4500-4*	4	451.1	62.72
R8VK4500-5*	5	451.1	78.40
R8VK4500-6*	6	451.1	94.08
R8VK4500-8*	8	451.1	125.44
R8VK4500-10*	10	451.1	156.80
R8VK4500-12*	12	451.1	188.16
R8VK4750-4*	4	476.1	65.52
R8VK4750-5*	5	476.1	81.90
R8VK4750-6*	6	476.1	98.28
R8VK4750-8*	8	476.1	131.04
R8VK4750-10*	10	476.1	163.80
R8VK4750-12*	12	476.1	196.56
R8VK5000-4*	4	501.1	68.32
R8VK5000-5*	5	501.1	85.40
R8VK5000-6*	6	501.1	102.48
R8VK5000-8*	8	501.1	136.64
R8VK5000-10*	10	501.1	170.80
R8VK5000-12*	12	501.1	204.96

Part Number	Number of Ribs	Outside Circumference (in)	Weight (lbs)
R8V Cross Section			
R8VK5600-4*	4	561.1	76.72
R8VK5600-5*	5	561.1	95.90
R8VK5600-6*	6	561.1	115.08
R8VK5600-8*	8	561.1	153.44
R8VK5600-10*	10	561.1	191.80
R8VK5600-12*	12	561.1	230.16

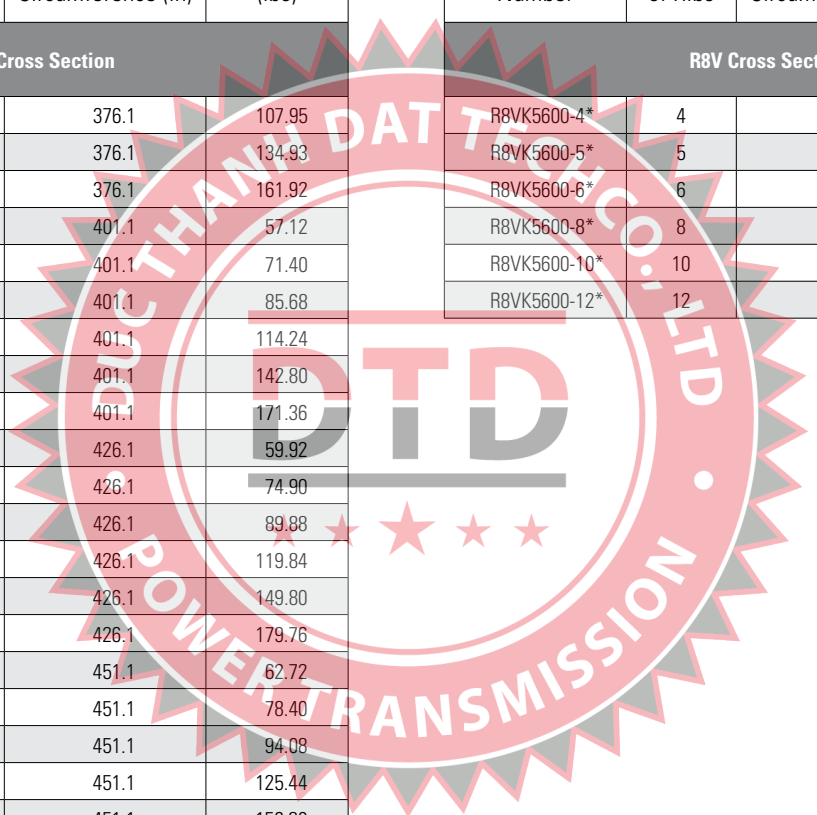

* Non-stock item. Minimum order quantity and/or extended lead times may apply. Contact customer service for availability.

Note: Maximum number of ribs available is 12.

Wedge-Band® Chipper Drive

Banded Belt

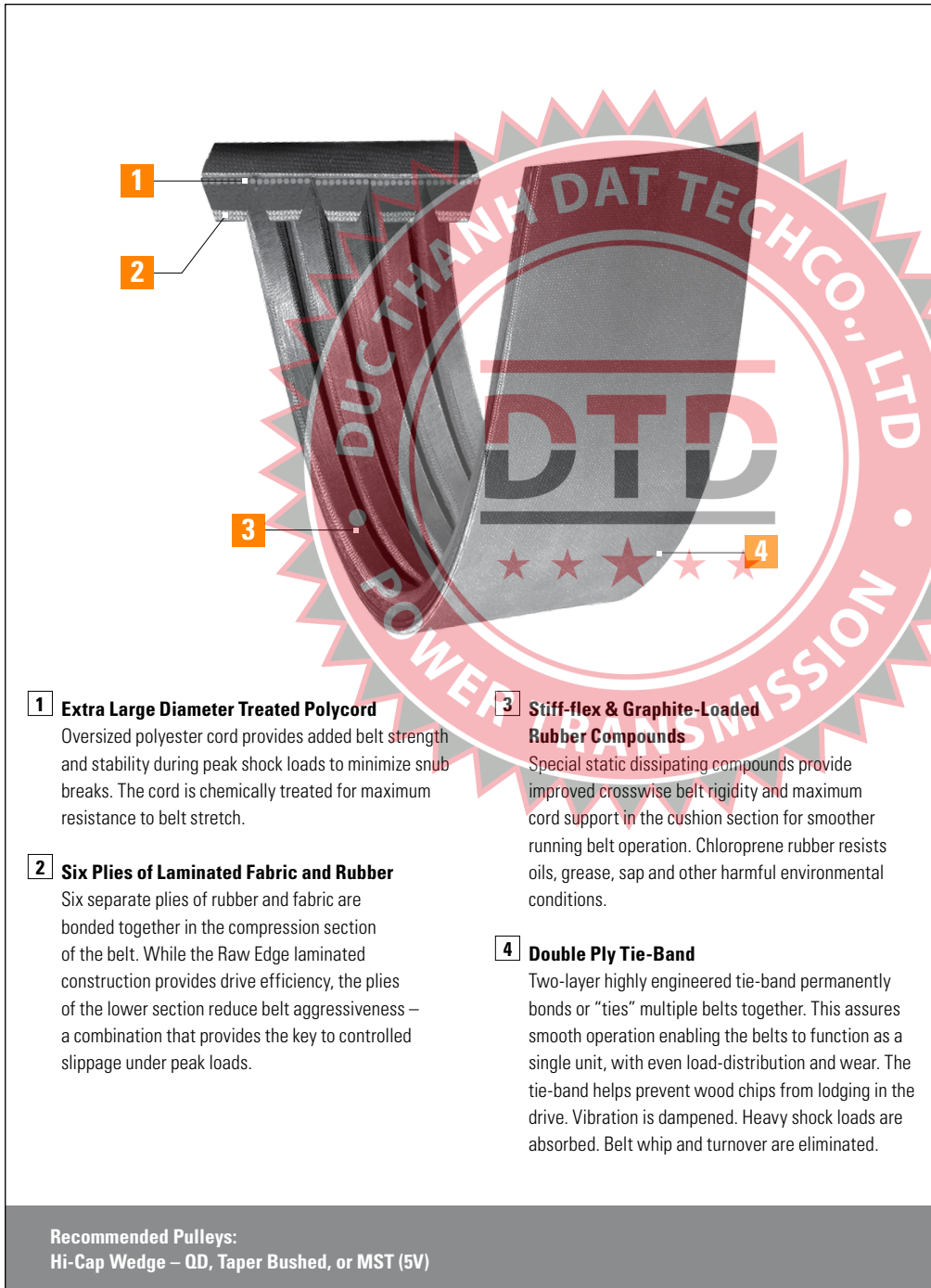

Built tough for forestry applications

Time and money saver

Ironclad guarantee

Applications:

- Chipper saws
- De-barker drives
- Head rigs
- & More

1 Extra Large Diameter Treated Polycord

Oversized polyester cord provides added belt strength and stability during peak shock loads to minimize snub breaks. The cord is chemically treated for maximum resistance to belt stretch.

2 Six Plies of Laminated Fabric and Rubber

Six separate plies of rubber and fabric are bonded together in the compression section of the belt. While the Raw Edge laminated construction provides drive efficiency, the plies of the lower section reduce belt aggressiveness – a combination that provides the key to controlled slippage under peak loads.

3 Stiff-flex & Graphite-Loaded Rubber Compounds

Special static dissipating compounds provide improved crosswise belt rigidity and maximum cord support in the cushion section for smoother running belt operation. Chloroprene rubber resists oils, grease, sap and other harmful environmental conditions.

4 Double Ply Tie-Band

Two-layer highly engineered tie-band permanently bonds or “ties” multiple belts together. This assures smooth operation enabling the belts to function as a single unit, with even load-distribution and wear. The tie-band helps prevent wood chips from lodging in the drive. Vibration is dampened. Heavy shock loads are absorbed. Belt whip and turnover are eliminated.

Recommended Pulleys:
Hi-Cap Wedge – QD, Taper Bushed, or MST (5V)

Wedge-Band® Chipper Drive

Banded Belt



Part Number Example: **R5VL1000-5** =

R **5V** **L** **1000** - **5**
 Banded Construction Cross Section Non-Cogged Construction Effective Length (inches in tenths: 100.0) Number of Ribs

Carlisle® Wedge-Band® Chipper Drive Belts are specially designed and constructed to meet the unique demands of the forestry industry.

Wedge-Band® Chipper Drive Banded Belt Part Numbers

Instead of using sets of individual belts this banded belt is engineered with a special Raw Edge laminated construction that provides perfect balance between the controlled transfer of power and slippage.

It is actually designed to slip during “overload” or drive stall conditions. By allowing the belt to have controlled slippage during overload situations, less heat is generated, which results in longer belt life.

The Carlisle® Wedge-Band® Chipper Drive belt will not only outperform your present belt, it will last longer, reducing emergency shutdowns and lost production time.

It’s the ideal belt for applications such as chipper saws, de-barker drives, head rigs and hogs.

So tough it’s backed by our Ironclad, money-back, performance guarantee.

Part Number	Number of Ribs	Outside Circumference (in)	Weight (lbs)
5VL – Banded Section Recommended Pulleys: Hi-Cap Wedge – OD, Taper Bushed, or MST (5V)			
R5VL800-5*	5	81.1	5.67
R5VL850-5*	5	86.1	5.98
R5VL900-5*	5	91.1	6.38
R5VL950-5*	5	96.1	6.74
R5VL1000-5*	5	101.1	7.09
R5VL1060-5*	5	107.1	6.80
R5VL1120-5*	5	113.1	7.95
R5VL1180-5*	5	119.1	7.60
R5VL1320-5*	5	133.1	9.37
R5VL1700-5*	5	171.1	12.08

* Non-stock item. Minimum order quantity and/or extended lead times may apply. Contact customer service for availability.

Super Vee-Band® Banded Belt

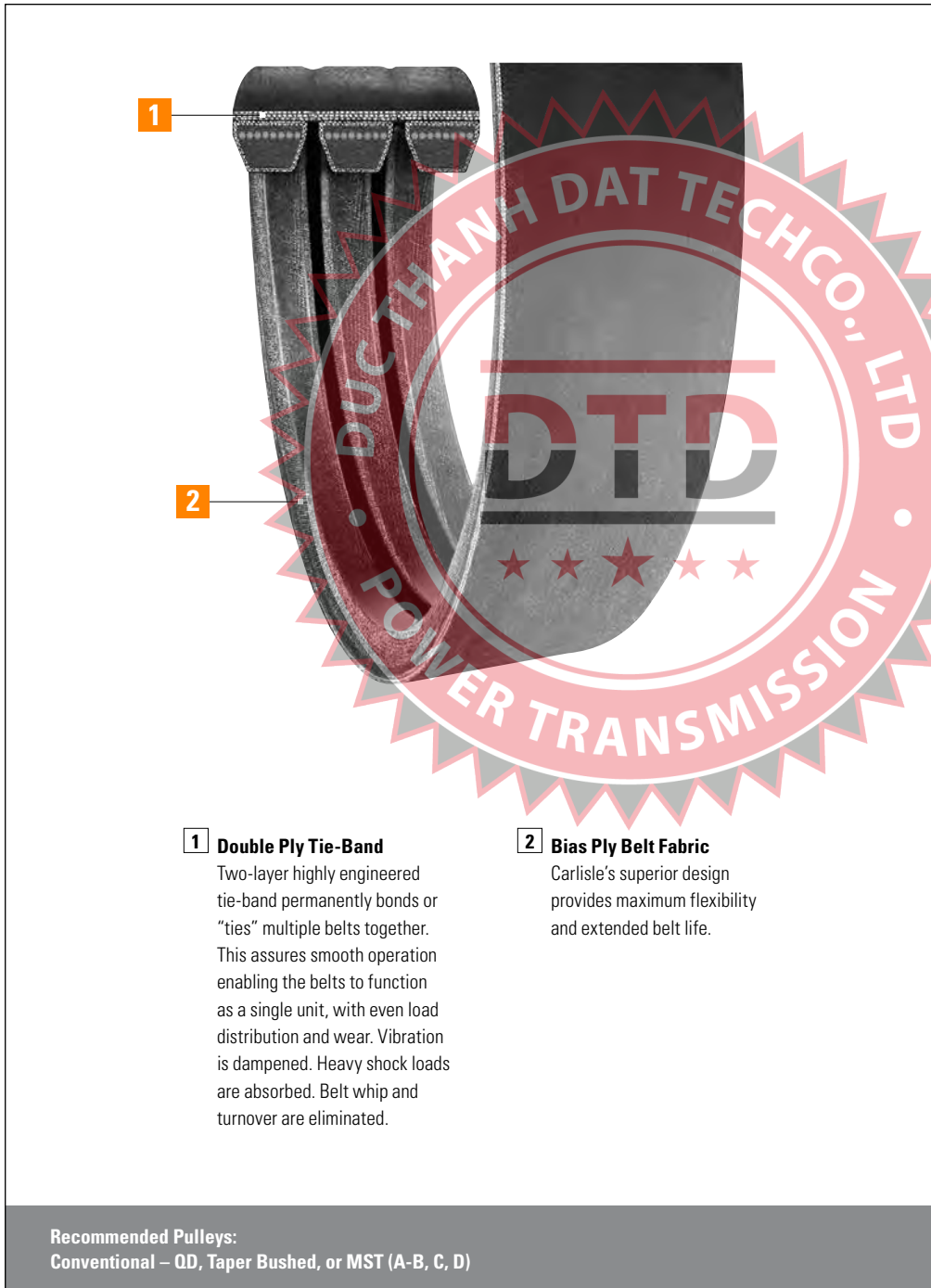

1 Double Ply Tie-Band
Two-layer highly engineered tie-band permanently bonds or “ties” multiple belts together. This assures smooth operation enabling the belts to function as a single unit, with even load distribution and wear. Vibration is dampened. Heavy shock loads are absorbed. Belt whip and turnover are eliminated.

2 Bias Ply Belt Fabric
Carlisle’s superior design provides maximum flexibility and extended belt life.

Provides cross-wise rigidity for multiple belt drives

Eliminates belt turnover and whip

Vee-Band® patented banding process

Available in a wide range of sizes

Applications:

- Rock crushers
- Vibrating equipment
- Saws
- Pumps
- & More

Recommended Pulleys:
Conventional – OD, Taper Bushed, or MST (A-B, C, D)

Super Vee-Band®

Banded Belt

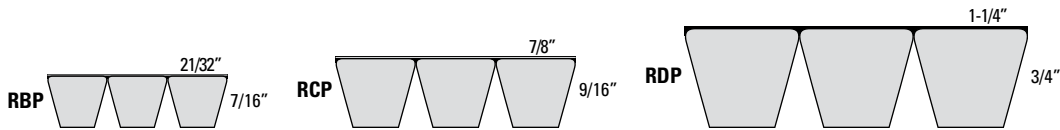

Super Vee-Band® is an ideal choice on classical drives where individual v-belts tend to roll over or whip severely due to fluctuating load conditions or harsh vibration.

The Carlisle® Super Vee-Band® line is specifically designed to handle the toughest industrial applications including rock crushers, vibrating equipment, saws and pumps.

Super Vee-Band features the always-reliable performance and classical design of the Carlisle Super Blue Ribbon®. It is especially suited for challenging applications that experience pulsating or stalling characteristics.

By combining multiple classical belts utilizing a patented banding process, the tendency for single belts to come off or turn over in drives subjected to fluctuating load tensions is eliminated.

The static-dissipating Super Vee-Band provides superior resistance to oil and heat which is critical in these tough industrial applications.

For complete part number, add number of ribs required as indicated in example provided.



Super Vee-Band® Banded Belt

Super Vee-Band® Banded Belt Part Numbers

Part Number Example: **RBP100-3 =**

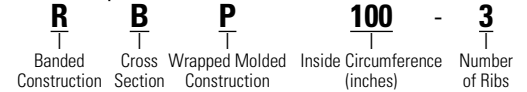

Part Number	Outside Circumference (in)	Weight Per Rib (lbs)
RBP – Banded BP Section Recommended Pulleys: Conventional – QD, Taper Bushed, or MST (A-B)		
RBP35	39.0	0.52
RBP38	42.0	0.56
RBP40	44.0	0.59
RBP41	45.0	0.61
RBP42	46.0	0.62
RBP43*	47.0	0.63
RBP44	48.0	0.65
RBP46	50.0	0.67
RBP48	52.0	0.70
RBP49	53.0	0.72
RBP50	54.0	0.73
RBP51	55.0	0.75
RBP52	56.0	0.76
RBP53	57.0	0.77
RBP54	58.0	0.78
RBP55	59.0	0.80
RBP56	60.0	0.81
RBP57	61.0	0.82
RBP58	62.0	0.84
RBP59	63.0	0.85
RBP60	64.0	0.87
RBP61	65.0	0.88
RBP62	66.0	0.90
RBP63	67.0	0.91
RBP64	68.0	0.92
RBP65	69.0	0.93
RBP66	70.0	0.95
RBP67	71.0	0.96
RBP68	72.0	0.98
RBP70	74.0	1.01
RBP71	75.0	1.02
RBP72	76.0	1.04
RBP73	77.0	1.05

Part Number	Outside Circumference (in)	Weight Per Rib (lbs)
RBP – Banded BP Section Recommended Pulleys: Conventional – QD, Taper Bushed, or MST (A-B)		
RBP74	78.0	1.06
RBP75	79.0	1.08
RBP77	81.0	1.11
RBP78	82.0	1.12
RBP79	83.0	1.13
RBP80	84.0	1.14
RBP81	85.0	1.16
RBP82	86.0	1.17
RBP83	87.0	1.19
RBP85	89.0	1.22
RBP87	91.0	1.24
RBP88	92.0	1.26
RBP90	94.0	1.28
RBP93	97.0	1.31
RBP95	99.0	1.34
RBP96	100.0	1.36
RBP97	101.0	1.37
RBP99	103.0	1.40
RBP100	104.0	1.41
RBP103	107.0	1.45
RBP105	109.0	1.48
RBP108	112.0	1.52
RBP112	116.0	1.58
RBP120	124.0	1.68
RBP124	128.0	1.74
RBP128	132.0	1.79
RBP130	134.0	1.82
RBP133	137.0	1.86
RBP136	140.0	1.91
RBP138	142.0	1.93
RBP140	144.0	1.96
RBP142	146.0	1.99
RBP144	148.0	2.02

Super Vee-Band®

Banded Belt

Super Vee-Band® Banded Belt Part Numbers

Part Number	Outside Circumference (in)	Weight Per Rib (lbs)
RBP – Banded BP Section Recommended Pulleys: Conventional – QD, Taper Bushed, or MST (A-B)		
RBP148	152.0	2.07
RBP158	162.0	2.21
RBP162	166.0	2.26
RBP173	177.0	2.41
RBP180	184.0	2.51
RBP195	199.0	2.72
RBP210	214.0	2.92
RBP225	227.5	3.10
RBP240	242.5	3.32
RBP255	257.5	3.52
RBP270	272.5	3.73
RBP285*	287.5	3.93
RBP300*	302.5	4.14
RBP315*	317.5	4.35
RCP – Banded CP Section Recommended Pulleys: Conventional – QD, Taper Bushed, or MST (C)		
RCP51*	56.3	1.24
RCP55*	60.3	1.34
RCP60*	65.3	1.45
RCP68	73.3	1.63
RCP71*	76.3	1.70
RCP75	80.3	1.79
RCP81	86.3	1.93
RCP85	90.3	2.02
RCP90	95.3	2.13
RCP96	101.3	2.26
RCP97	102.3	2.28
RCP99	104.3	2.33
RCP100	105.3	2.35
RCP105	110.3	2.47
RCP108	113.3	2.53
RCP109	114.3	2.56
RCP112	117.3	2.62

Part Number	Outside Circumference (in)	Weight Per Rib (lbs)
RCP – Banded CP Section Recommended Pulleys: Conventional – QD, Taper Bushed, or MST (C)		
RCP115	120.3	2.69
RCP120	125.3	2.80
RCP124	129.3	2.90
RCP128	133.3	2.99
RCP136	141.3	3.17
RCP144	149.3	3.35
RCP158	163.3	3.67
RCP162	167.3	3.76
RCP173	178.3	4.01
RCP180	185.3	4.11
RCP195	200.3	4.45
RCP210	215.3	4.78
RCP225	228.3	5.07
RCP240	243.3	5.41
RCP255	258.3	5.74
RCP270	273.3	6.07
RCP285	288.3	6.41
RCP300	303.3	6.74
RCP315	318.3	7.08
RCP330	333.3	7.41
RCP345	348.3	7.75
RCP360	363.3	8.15
RCP390	393.3	8.82
RCP420	423.3	9.50

Super Vee-Band® Banded Belt

Part Number Example: **RBP148-3** = **R** **B** **P** **148** - **3**
Banded Construction Cross Section Wrapped Molded Construction Inside Circumference (inches) Number of Ribs

Part Number	Outside Circumference (in)	Weight Per Rib (lbs)
RDP – Banded DP Section Recommended Pulleys: Conventional – QD, Taper Bushed, or MST (D)		
RDP120*	126.4	5.22
RDP128*	134.4	5.40
RDP144*	150.4	6.22
RDP158*	164.4	6.81
RDP162*	168.4	6.98
RDP173*	179.4	7.44
RDP180*	186.4	7.73
RDP195*	201.4	8.36
RDP210*	216.4	8.99
RDP225*	228.9	9.51
RDP240*	243.9	10.14
RDP255*	258.9	10.77
RDP270*	273.9	11.40
RDP285*	288.9	12.03
RDP300	303.9	12.66
RDP315	318.9	13.29
RDP330	333.9	13.92
RDP345*	348.9	14.55
RDP360	363.9	15.29
RDP390	393.9	16.56
RDP420*	423.9	17.83
RDP450*	453.9	19.10
RDP480*	483.9	20.37
RDP540*	543.9	22.90
RDP600*	603.9	25.44
RDP660*	663.9	27.98

For complete part number, add number of ribs required as indicated in example above.

* Non-stock item. Minimum order quantity and/or extended lead times may apply. Contact customer service for availability.

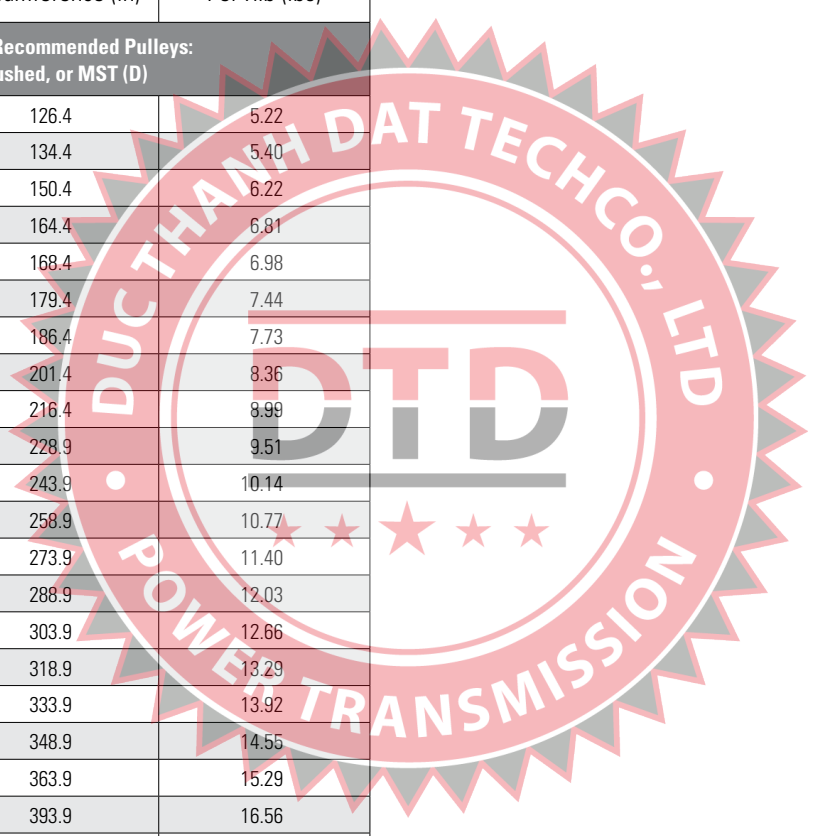

Banded Belts

Durapower® II Raw Edge FHP Belt

Light Duty Fractional Horsepower Belt



Durapower® II Raw Edge FHP Belt

Light Duty Fractional Horsepower Belt

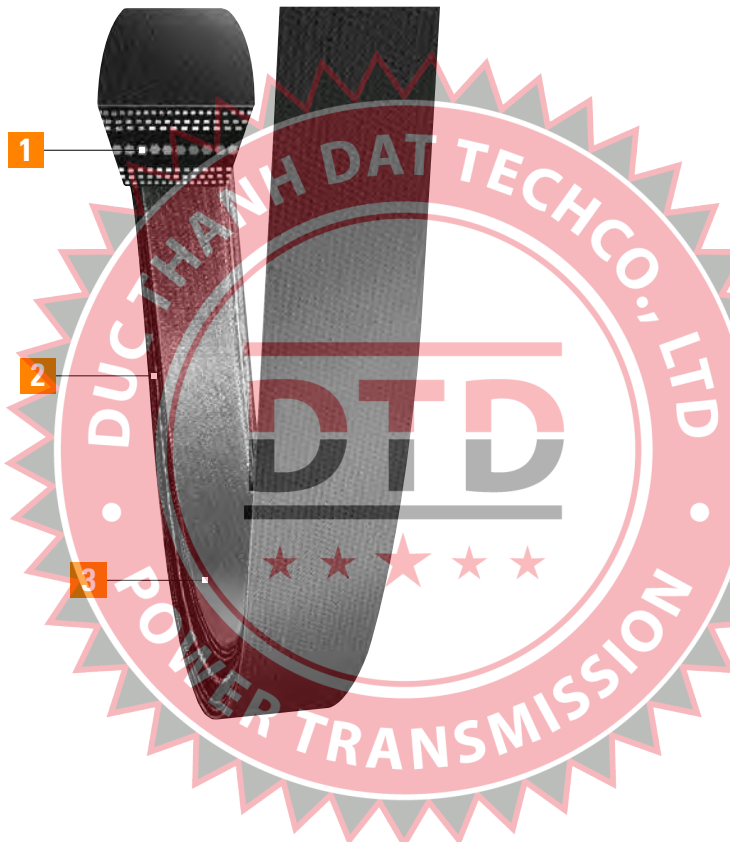

1 Load Carrying Section

High modulus polyester cords are specially treated to carry loads without stretching. Lower cord placement reduces stress when used with backside idlers.

2 Raw Edge Sidewalls

Performance-proven to grip pulley grooves better than wrapped type belts, to minimize belt slip, noise and drive vibration.

3 Compression Section

Specially formulated rubber compounds located between the cushion stock and compression fabric support cords evenly and resist flex fatigue. Also provides superior resistance to oil, grease, dirt and ozone.

Energy efficient

Reduces maintenance and downtime

Assures smoother, quieter operation with less vibration

Lengthens belt life and improves system-wide performance

Applications:
HVAC
Fans
& More

Light Duty Belts

Recommended Pulleys:
FHP – Bore-to-Size, MST (AK, BK)

Durapower® II Raw Edge FHP Belt

Light Duty Fractional Horsepower Belt

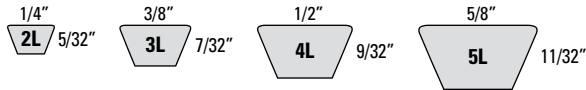

The Carlisle® Durapower® II by Timken is a competitively priced Raw Edge v-belt that provides value added benefits – superior performance and efficiency.

Durapower® II's strength and lasting power can be attributed to Timken engineers and their ability to successfully combine the advantages of Raw Edge technology with the unique CNA belt building process. Centralized Neutral Axis (CNA) refers to the placement of cords in the middle of the belt's cross section. This lower-than-normal cord placement gives the belt greater flexibility and keeps it stable in the pulleys on high shock load applications. To further assure top performance, Durapower II utilizes fiber-loaded rubber called stiff-flex – a compound previously found only in higher priced premium belts.

By combining Raw Edge belt sidewalls, CNA cord placement and construction using specially formulated rubber, Timken offers Durapower II – an economically proven v-belt with value added benefits unequalled at any price in light duty v-belts.

Belt Life Comparison

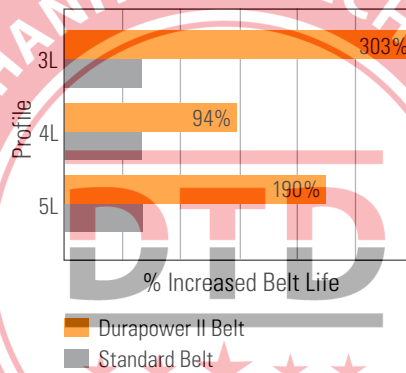

Durapower® II Raw Edge FHP Belt

Light Duty Fractional Horsepower Belt

Durapower® II FHP Belt Part Numbers

Part Number Example: **4L200R** = **4L** **200** **R**
Cross Section Outside Circumference (inches in tenths: 20.0) Raw Edge Construction

Part Number	Outside Circumference (in)	Weight (lbs)
2L Section Recommended Pulleys: FHP – Bore-to-Size, MST (AK, BK)		
2L110R	11.0	0.02
2L140R	14.0	0.03
2L150R	15.0	0.03
2L160R*	16.0	0.03
2L200R	20.0	0.04
2L230R*	23.0	0.05
2L250R	25.0	0.05
2L360R*	36.0	0.07
3L Section Recommended Pulleys: FHP – Bore-to-Size, MST (AK, BK)		
3L150†	15.0	0.05
3L160†	16.0	0.05
3L170†	17.0	0.05
3L180†	18.0	0.06
3L190R	19.0	0.06
3L200R	20.0	0.07
3L210R	21.0	0.07
3L220R	22.0	0.07
3L230R	23.0	0.08
3L240R	24.0	0.08
3L250R	25.0	0.08
3L260R	26.0	0.09
3L270R	27.0	0.09
3L280R	28.0	0.09
3L290R	29.0	0.10
3L300R	30.0	0.10
3L310R	31.0	0.11
3L320R	32.0	0.11
3L330R	33.0	0.11
3L340R	34.0	0.12
3L350R	35.0	0.12
3L360R	36.0	0.12

Part Number	Outside Circumference (in)	Weight (lbs)
3L Section Recommended Pulleys: FHP – Bore-to-Size, MST (AK, BK)		
3L370R	37.0	0.13
3L380R	38.0	0.13
3L390R	39.0	0.13
3L400R	40.0	0.14
3L410R	41.0	0.14
3L420R	42.0	0.14
3L430R	43.0	0.15
3L440R	44.0	0.15
3L450R	45.0	0.15
3L460R	46.0	0.16
3L470R	47.0	0.16
3L480R	48.0	0.16
3L490R	49.0	0.17
3L500R	50.0	0.17
3L510R	51.0	0.17
3L520R*	52.0	0.18
3L530R	53.0	0.18
3L540R*	54.0	0.18
3L550R*	55.0	0.19
3L560R	56.0	0.19
3L570R	57.0	0.19
3L580R*	58.0	0.20
3L590R*	59.0	0.20
3L600R	60.0	0.21
3L610R*	61.0	0.21
3L620R*	62.0	0.21
3L630R*	63.0	0.22
3L670R*	67.0	0.23
3L690R*	69.0	0.24
3L710R*	71.0	0.24
3L740R*	74.0	0.25
3L750R*	75.0	0.26

Light Duty Belts

Durapower® II Raw Edge FHP Belt

Light Duty Fractional Horsepower Belt

Durapower® II FHP Belt Part Numbers

Part Number	Outside Circumference (in)	Weight (lbs)
4L Section Recommended Pulleys: FHP – Bore-to-Size, MST (AK, BK)		
4L160*†	16.0	0.08
4L170†	17.0	0.09
4L180†	18.0	0.09
4L190R	19.0	0.11
4L200R	20.0	0.11
4L210R	21.0	0.12
4L220R	22.0	0.12
4L230R	23.0	0.13
4L240R	24.0	0.14
4L250R	25.0	0.14
4L260R	26.0	0.15
4L270R	27.0	0.15
4L280R	28.0	0.16
4L290R	29.0	0.16
4L300R	30.0	0.17
4L305R*	30.5	0.17
4L310R	31.0	0.18
4L315R*	31.5	0.18
4L320R	32.0	0.18
4L330R	33.0	0.19
4L340R	34.0	0.19
4L350R	35.0	0.20
4L360R	36.0	0.21
4L370R	37.0	0.21
4L380R	38.0	0.22
4L390R	39.0	0.22
4L400R	40.0	0.23
4L410R	41.0	0.23
4L420R	42.0	0.24
4L430R	43.0	0.25
4L440R	44.0	0.25
4L450R	45.0	0.26
4L460R	46.0	0.26

Part Number	Outside Circumference (in)	Weight (lbs)
4L Section Recommended Pulleys: FHP – Bore-to-Size, MST (AK, BK)		
4L470R	47.0	0.27
4L480R	48.0	0.27
4L490R	49.0	0.28
4L500R	50.0	0.29
4L510R	51.0	0.29
4L515R*	51.0	0.30
4L520R	52.0	0.30
4L530R	53.0	0.30
4L540R	54.0	0.31
4L550R	55.0	0.32
4L560R	56.0	0.32
4L570R	57.0	0.33
4L580R	58.0	0.33
4L590R	59.0	0.34
4L600R	60.0	0.35
4L610R	61.0	0.35
4L620R	62.0	0.36
4L630R	63.0	0.36
4L640R	64.0	0.37
4L650R	65.0	0.38
4L660R	66.0	0.38
4L670R	67.0	0.39
4L680R	68.0	0.39
4L690R	69.0	0.40
4L700R	70.0	0.40
4L710R	71.0	0.41
4L720R	72.0	0.41
4L730R*	73.0	0.42
4L740R	74.0	0.42
4L750R*	75.0	0.43
4L760R*	76.0	0.44
4L770R	77.0	0.44
4L780R*	78.0	0.45

Durapower® II Raw Edge FHP Belt

Light Duty Fractional Horsepower Belt

Part Number Example: **5L460R** = **5L** **460** **R**
Cross Section Outside Circumference (inches in tenths: 46.0) Raw Edge Construction

Part Number	Outside Circumference (in)	Weight (lbs)
4L Section Recommended Pulleys: FHP – Bore-to-Size, MST (AK, BK)		
4L790R	79.0	0.45
4L800R*	80.0	0.46
4L810R	81.0	0.46
4L820R*	82.0	0.47
4L830R*	83.0	0.48
4L840R*	84.0	0.48
4L850R*	85.0	0.49
5L Section Recommended Pulleys: FHP – Bore-to-Size, MST (AK, BK)		
5L230R	23.0	0.20
5L240R	24.0	0.21
5L250R	25.0	0.22
5L260R	26.0	0.22
5L270R	27.0	0.23
5L280R	28.0	0.24
5L290R	29.0	0.25
5L300R	30.0	0.26
5L310R	31.0	0.27
5L320R	32.0	0.28
5L330R	33.0	0.29
5L340R	34.0	0.29
5L350R	35.0	0.31
5L360R	36.0	0.31
5L370R	37.0	0.32
5L380R	38.0	0.33
5L390R	39.0	0.34
5L400R	40.0	0.35
5L410R	41.0	0.36
5L420R	42.0	0.37
5L430R	43.0	0.38
5L440R	44.0	0.39
5L450R	45.0	0.39
5L460R	46.0	0.40

Part Number	Outside Circumference (in)	Weight (lbs)
5L Section Recommended Pulleys: FHP – Bore-to-Size, MST (AK, BK)		
5L470R	47.0	0.41
5L480R	48.0	0.42
5L490R	49.0	0.43
5L500R	50.0	0.44
5L510R	51.0	0.45
5L520R	52.0	0.46
5L530R	53.0	0.47
5L540R	54.0	0.48
5L550R	55.0	0.48
5L560R	56.0	0.49
5L570R	57.0	0.50
5L580R	58.0	0.51
5L590R	59.0	0.52
5L600R	60.0	0.53
5L610R	61.0	0.54
5L620R	62.0	0.55
5L630R	63.0	0.56
5L640R*	64.0	0.57
5L650R	65.0	0.57
5L660R	66.0	0.58
5L670R	67.0	0.59
5L680R	68.0	0.60
5L690R	69.0	0.61
5L700R	70.0	0.62
5L710R	71.0	0.63
5L720R*	72.0	0.61
5L730R	73.0	0.62
5L740R*	74.0	0.63
5L750R*	75.0	0.64
5L760R*	76.0	0.65
5L770R*	77.0	0.66
5L780R	78.0	0.69
5L790R*	79.0	0.70

Light Duty Belts

Durapower® II Raw Edge FHP Belt

Light Duty Fractional Horsepower Belt

Durapower® II FHP Belt Part Numbers

Part Number	Outside Circumference (in)	Weight (lbs)
5L Section Recommended Pulleys: FHP – Bore-to-Size, MST (AK, BK)		
5L800R*	80.0	0.71
5L810R*	81.0	0.69
5L820R*	82.0	0.70
5L830R*	83.0	0.74
5L840R*	84.0	0.75
5L850R*	85.0	0.75

* Non-stock item. Minimum order quantity and/or extended lead times may apply. Contact customer service for availability.

† Available in wrapped construction only.

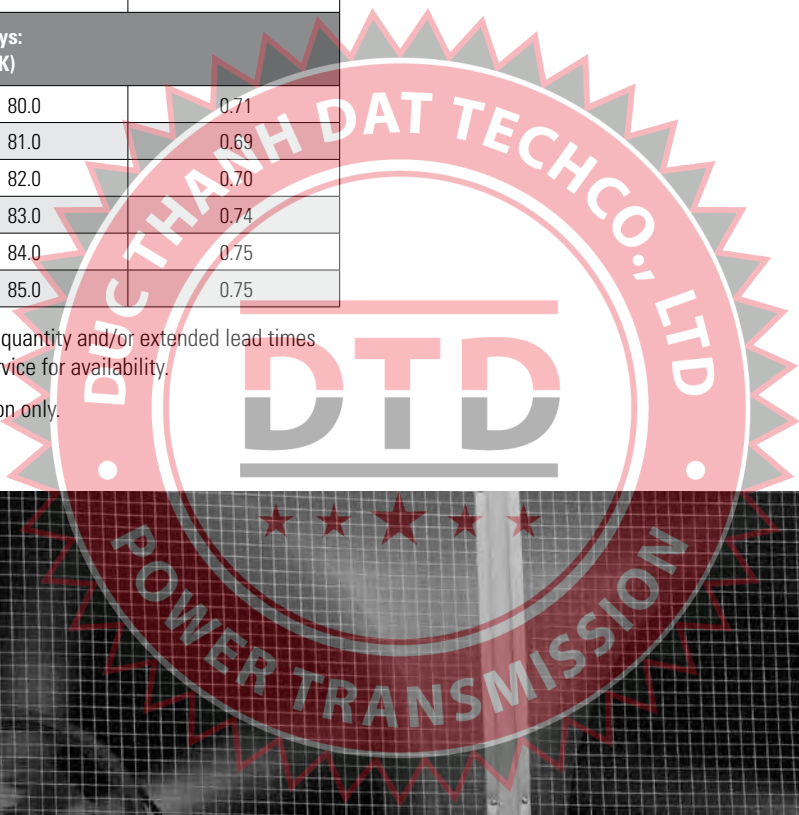

Dry Can Specialty Belt

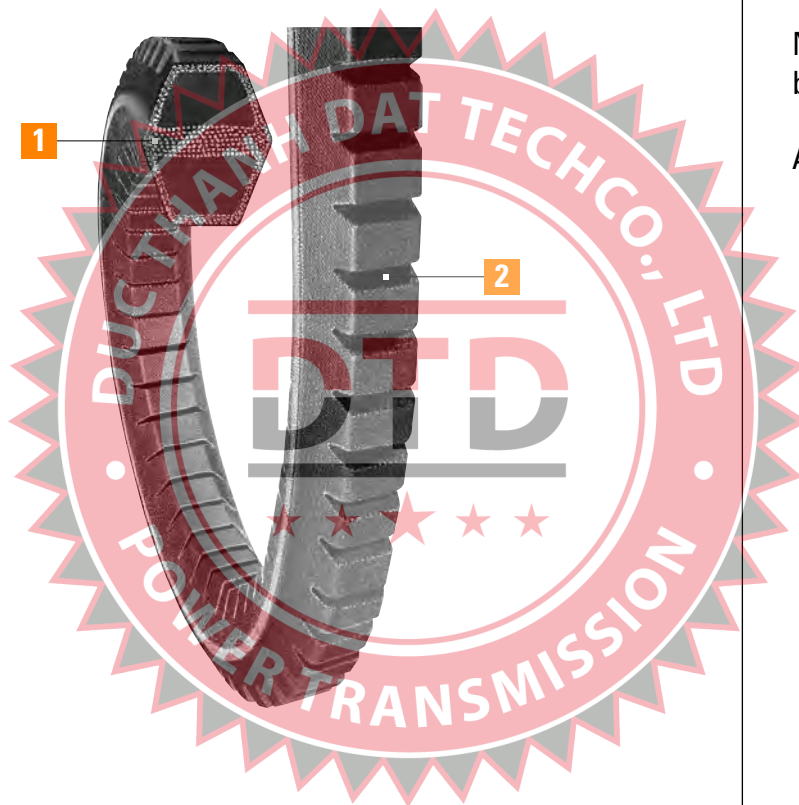

Unique deep groove
for drying machines

Notched for
better flexibility

Applications:
Textile industry
Drying cans

1 Multiple cord plies for greater strength and durability.

2 Notched design for greater flexibility and increased life.

Recommended Pulleys:
Conventional – OD, Taper Bushed, or MST (C)

Specialty Belts

Dry Can

Specialty Belt

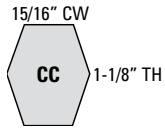

Part Number Example: **CC600S** = **CC** **600** **S**
Cross Section Double Angle Pitch Length (inches) Notched Cog Construction

The original deep-groove notched design is specifically developed for the demanding textile industry double angle “CC” drives.

Deep groove double “CC” belts are designed for drives with long center, serpentine applications. Dry Can specialty belts are notched for added flexibility.

Dry Can Specialty Belt Part Numbers

Important Application Information

Dry Can belts are normally used as a single belt on a drive and matching is not required. When ordering two or more Dry Can belts to be used as a matched set on the same drive, please specify that the belts must be a matched set.

Part Number	Pitch Length (in)	Weight (lbs)
C Belt Recommended Pulleys:		
Conventional – QD, Taper Bushed, or MST (C)		
CC210S	214.1	7.97
CC240S*	242.1	9.02
CC270S*	272.1	10.14
CC300S*	302.1	11.25
CC330S	332.1	12.37
CC360S	362.1	13.49
CC390S*	392.1	14.61
CC420S	422.1	15.73
CC440S	442.1	16.47
CC450S*	452.1	16.84
CC480S	482.1	17.96
CC540S	542.1	20.20
CC550S	552.1	20.57
CC600S	602.1	22.43
CC640S	642.1	23.92
CC660S	662.1	24.67
CC670S	672.1	25.04
CC680S*	682.1	25.41
CC700S*	702.1	26.16
CC720S	722.1	26.91
CC750S	752.1	28.02
CC780S	782.1	29.14
CC800S*	802.1	29.89
CC840S	842.1	31.38
CC900S	902.1	33.61

* Non-stock item. Minimum order quantity and/or extended lead times may apply. Contact customer service for availability.

For sizes not listed contact customer service for availability.

Thoro-Twist™ V-Belt

Specialty Belt

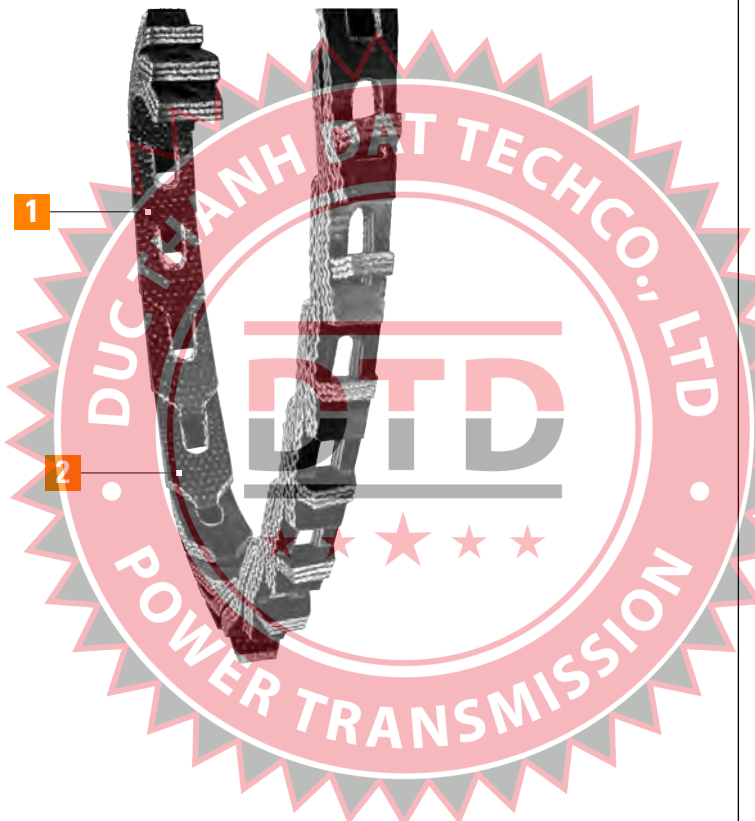

1 High performance polyurethane elastomer, reinforced with multiple plies of polyester fabric.

2 Oil, chemical, and temperature resistant.

Perfect candidate for v-belt drives that have no take-up adjustment capability

Ideal as an emergency replacement belt

Strong, flexible, fabric reinforced urethane construction

Applications:
Emergency replacement

Recommended Pulleys:
Conventional – QD, Taper Bushed, or MST (A-B, C); FHP – Bore-to-Size and MST (AK, BK)

Specialty Belts

Thoro-Twist™ V-Belt

Specialty Belt

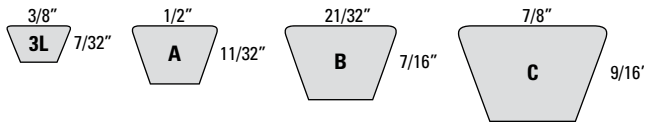

Part Number Example: **3LTwist** = **3L** **Twist**
↓ Cross Section ↓ Thoro-Twist (link) Belting

Thoro-Twist™ v-belt is a perfect candidate for drives that have no take-up adjustment capability or for use as an emergency replacement belt.

Carlisle® Thoro-Twist™ v-belts outperform other link v-belts time after time in harsh environments. An incredibly strong, yet flexible belt with the same horsepower ratings as classical section v-belts.

Easy installation. Thoro-Twist v-belts can be made to required length, by hand, in seconds and rolled onto the drive just like a bicycle chain.

Thoro-Twist v-belts have the same cross section dimensions as regular belts and can be installed on existing sheaves with no changes in setup.

Thoro-Twist™ Part Numbers

Part Number	Top Width (in)	Replaces	Weight (lbs)	MOQ (meters)
Recommended Pulleys: Conventional – QD, Taper Bushed, or MST (A-B, C), FHP – Bore-to-Size and MST (AK, BK)				
3LTwist	3/8	3L, O	11.50	30
ATwist	1/2	4L, A	14.50	30
BTwist	21/32	5L, B	22.50	30
CTwist	7/8	C	32.50	30

Minimum order quantity: One carton, 30 meter roll (approximately 98')

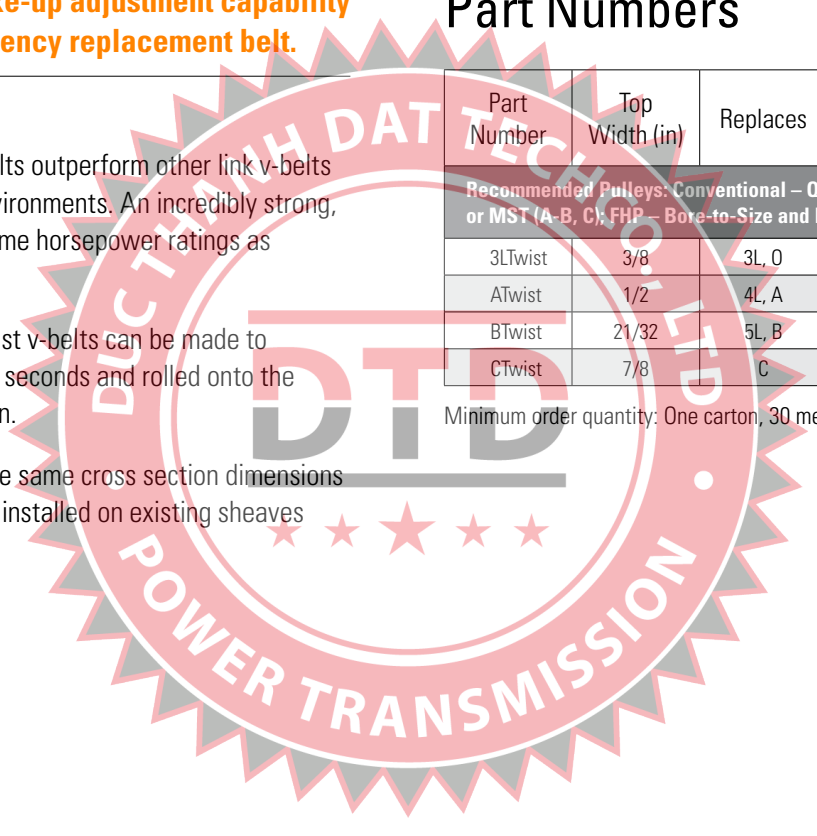

Round Specialty Belt

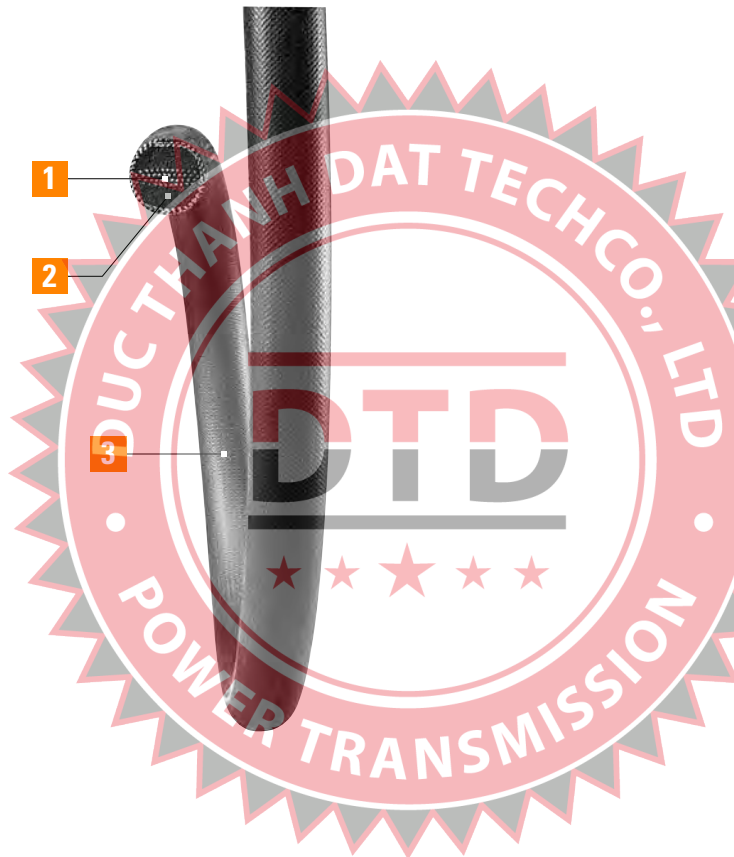

Minimal stretch for minimum take-up requirements

No splice for added durability

Available in most popular sizes for conveyor applications

Applications:
Conveyors
& More

1 High-Modulus Cords
Carries HP loads with minimum stretch. Results in better belt stability and fewer take-up adjustments.

2 Compression Section
Provides more uniform cord support and improves belt flex life.

3 Heavy Duty Cover
Stress relieved fabric cover flexes better for improved belt life.

Recommended Pulleys:
Conventional – OD, Taper Bushed, or MST (A-B)

Round Specialty Belt

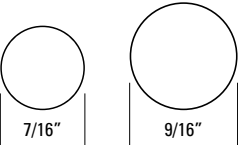

Round belts are a high performance solution for conveyors, quarter-turn, twisted, and serpentine drives.

Round belts are used on quarter-turn or twisted drives and serpentine drives. Round belts are available in various lengths in 7/16" and 9/16" diameters.

Other sizes are available. Please contact your Timken belts Customer Service team. Extended lead times and minimum order quantities may apply.



Round Specialty Belt

Round Belt Part Numbers

Part Number Example: **716R100** = **716** **R** **100**
Diameter (fractional inches: 7/16") Round Belt Construction Effective Length (inches)

Part Number	Diameter (in)	Effective Length (in)	Weight (lbs)
7/16" Diameter Recommended Pulleys: Conventional – QD, Taper Bushed, or MST (A-B)			
716R70*	0.438	70.0	0.43
716R71*	0.438	71.0	0.43
716R72*	0.438	72.0	0.44
716R73*	0.438	73.0	0.45
716R74*	0.438	74.0	0.45
716R75*	0.438	75.0	0.46
716R76*	0.438	76.0	0.47
716R77*	0.438	77.0	0.47
716R78*	0.438	78.0	0.48
716R79*	0.438	79.0	0.48
716R80*	0.438	80.0	0.49
716R81*	0.438	81.0	0.50
716R82*	0.438	82.0	0.50
716R83*	0.438	83.0	0.51
716R84*	0.438	84.0	0.51
716R85*	0.438	85.0	0.52
716R86*	0.438	86.0	0.53
716R87*	0.438	87.0	0.53
716R88*	0.438	88.0	0.54
716R89*	0.438	89.0	0.54
716R90*	0.438	90.0	0.55
716R91*	0.438	91.0	0.56
716R92*	0.438	92.0	0.56
716R93*	0.438	93.0	0.57
716R94*	0.438	94.0	0.58
716R95*	0.438	95.0	0.58
716R96*	0.438	96.0	0.59
716R97*	0.438	97.0	0.59
716R98*	0.438	98.0	0.60
716R99*	0.438	99.0	0.61
716R100*	0.438	100.0	0.61
716R101*	0.438	101.0	0.62
716R102*	0.438	102.0	0.62

Part Number	Diameter (in)	Effective Length (in)	Weight (lbs)
7/16" Diameter Recommended Pulleys: Conventional – QD, Taper Bushed, or MST (A-B)			
716R103*	0.438	103.0	0.63
716R104*	0.438	104.0	0.64
716R105*	0.438	105.0	0.64
716R106*	0.438	106.0	0.65
716R151	0.438	150.7	0.92
9/16" Diameter Recommended Pulleys: Conventional – QD, Taper Bushed, or MST (A-B)			
916R70*	0.563	70.0	0.70
916R71*	0.563	71.0	0.71
916R72*	0.563	72.0	0.72
916R73*	0.563	73.0	0.73
916R74*	0.563	74.0	0.74
916R75*	0.563	75.0	0.75
916R76*	0.563	76.0	0.76
916R77*	0.563	77.0	0.77
916R78*	0.563	78.0	0.79
916R79*	0.563	79.0	0.80
916R80*	0.563	80.0	0.81
916R81*	0.563	81.0	0.82
916R82*	0.563	82.0	0.83
916R83*	0.563	83.0	0.84
916R84*	0.563	84.0	0.85
916R85*	0.563	85.0	0.86
916R86*	0.563	86.0	0.87
916R87*	0.563	87.0	0.88
916R88*	0.563	88.0	0.89
916R89*	0.563	89.0	0.90
916R90*	0.563	90.0	0.91
916R91*	0.563	91.0	0.92
916R92*	0.563	92.0	0.93
916R93*	0.563	93.0	0.94
916R94*	0.563	94.0	0.95
916R95*	0.563	95.0	0.96

Specialty Belts

Round Specialty Belt

Round Belt Part Numbers

Part Number Example: **916R96** = **916** **R** **96**
Diameter (fractional inches: 9/16") Round Belt Construction Effective Length (inches)

Part Number	Diameter (in)	Effective Length (in)	Weight (lbs)
9/16" Diameter Recommended Pulleys: Conventional – QD, Taper Bushed, or MST (A-B)			
916R96*	0.563	96.0	0.97
916R97*	0.563	97.0	0.98
916R98*	0.563	98.0	0.99
916R99*	0.563	99.0	1.00
916R100*	0.563	100.0	1.01
916R101*	0.563	101.0	1.02
916R102*	0.563	102.0	1.03
916R103*	0.563	103.0	1.04
916R104*	0.563	104.0	1.05
916R105*	0.563	105.0	1.06
916R106*	0.563	106.0	1.07
916R107*	0.563	107.0	1.08
916R108*	0.563	108.0	1.09
916R109*	0.563	109.0	1.10
916R110*	0.563	110.0	1.11
916R111*	0.563	111.0	1.12
916R112*	0.563	112.0	1.13
916R113*	0.563	113.0	1.14
916R114*	0.563	114.0	1.15
916R115*	0.563	115.0	1.16
916R116*	0.563	116.0	1.17
916R117*	0.563	117.0	1.18
916R118*	0.563	118.0	1.19
916R119*	0.563	119.0	1.20
916R120*	0.563	120.0	1.21
916R128*	0.563	128.0	1.29
916R135*	0.563	135.0	1.36
916R144*	0.563	144.0	1.45
916R148*	0.563	148.0	1.49
916R155*	0.563	155.0	1.57
916R166*	0.563	166.0	1.68
916R172*	0.563	172.0	1.74
916R176*	0.563	176.0	1.78

Part Number	Diameter (in)	Effective Length (in)	Weight (lbs)
9/16" Diameter Recommended Pulleys: Conventional – QD, Taper Bushed, or MST (A-B)			
916R190*	0.563	190.0	1.92
916R200*	0.563	200.0	2.02
916R210*	0.563	210.0	2.12
916R233	0.563	233.0	2.36
916R250	0.563	250.0	2.53
916R270	0.563	270.0	2.73
916R308	0.563	308.0	3.12
916R331*	0.563	331.0	3.35
916R341*	0.563	341.0	3.45
916R345*	0.563	345.0	3.49
916R366*	0.563	366.0	3.74
916R386	0.563	386.0	3.95
916R416*	0.563	416.0	4.25
916R447*	0.563	447.0	4.57
916R465	0.563	465.0	4.75
916R500*	0.563	500.0	5.11
916R522*	0.563	522.0	5.33
916R564	0.563	564.0	5.76
916R572*	0.563	572.0	5.84
916R600*	0.563	600.0	6.13
916R603*	0.563	603.0	6.16
916R660*	0.563	660.0	6.74
916R762*	0.563	762.0	7.78

* Non-stock item. Minimum order quantity and/or extended lead times may apply. Contact customer service for availability.

Other sizes are made-to-order; minimum order quantities apply.

Round Specialty Belt



Specialty Belts

Martin Sprockets, Sheaves & Bushings

Timken is proud to partner with *Martin* Sprocket & Gear, Inc. to provide full coverage for all your belt driven power transmission needs.

Martin sprockets, sheaves and bushings are now available and can be ordered along with Carlisle belts by Timken.

For optimum performance and increased belt life, use Martin's comprehensive line of heavy-duty industrial sheaves, light-duty sheaves and synchronous sprockets.

Timken shares Martin's philosophy of providing quality products, exceptional inventory and service "second to none."

Timken is your one-stop for belt drive solutions:

- Product
- Service
- Delivery
- Quality
- Engineering Support

Martin®, MPC®, MST®, HI-CAP® are registered trademarks of Martin Sprocket & Gear, Inc.



Martin Sprockets, Sheaves & Bushings

Synchronous Drives

Timing Pulleys

Timing Pulley Nomenclature	196
XL	197
L	198
H	203
XH	210

High Torque Sprockets

5mm	213
8mm	214
14mm	218
20mm	223

HTS® Synchronous Sprockets

HTS Synchronous Sprockets Nomenclature	227
8mm	228
14mm	230

MPC® Sprockets

MPC Sprockets Nomenclature	235
8mm	236
8mm Air Cool Heat Exchange	240
14mm	241
14mm Air Cool Heat Exchange	246

V-Belt Drives

Sheave Nomenclature 248

QD Hi-Cap® Wedge	
3V Section	249
5V Section	252
8V Section	256

QD Conventional	
A-B Combination Groove	258
C Section	262
D Section	265

Taper Bushed Hi-Cap Wedge	
3V Section	267
5V Section	270
8V Section	273

Taper Bushed Conventional	
A-B Combination Groove	275
C Section	278
D Section	281

FHP Sheaves	
AK/2AK Bored-To-Size	283
AK-H/2AK-H MST® Bushed	285
BK/2BK Bored-To-Size	287
BK-H/2BK-H MST Bushed	289

Variable Pitch Sheaves	
1VP/2VP Bored-To-Size	291

MST® Hi-Cap Wedge	
3V Section	293
5V Section	299
8V Section	303

MST Conventional	
A-B Combination Groove	307
C Section	315

Interchangeable Bushings

QD Bushings	
All Steel QD Bushings	325
Standard QD Bushings	326
QD Short Bushings	327

Taper Bushings	
Installation & Removal	328
Dimensions	
No. 1008-3030	329
No. 3535-5050	330
No. 4030-5040	330
No. 6050-120100	331
Metric and Reborable	332

MST® Bushings	
Bushing Specifications	333

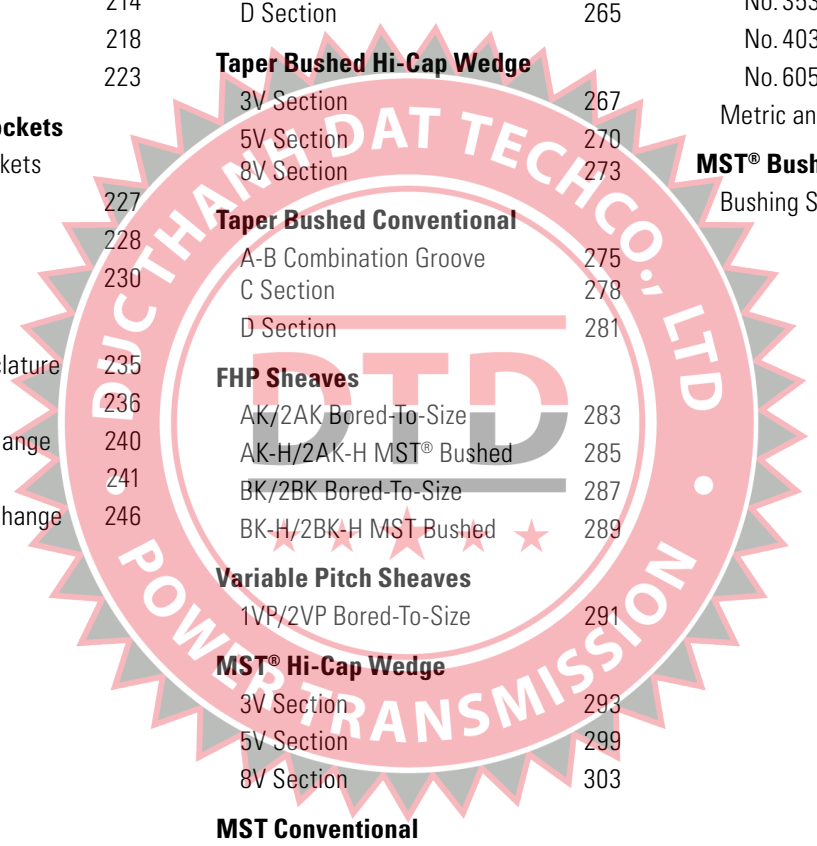

Timing Pulleys

STOCK TIMING PULLEYS

1/5" - 7/8" PITCH
QD – TAPER BUSHED
AND STOCK BORE



Stock Bore



Taper Bushed



QD

PITCH IN.	PULLEY DESIGNATION
1/5"	XL (Extra Light)
3/8"	L (Light)
1/2"	H (Heavy)
7/8"	XH (Extra Heavy)

Martin Timing Pulleys are manufactured to extremely close specifications and are stocked in minimum plain bore, Taper Bushed and Q.D. bushed styles depending on size and pitch.

See tables for stock pulley types. Bushings are priced separately and must be added to pulley price.

Illustrations below indicate stock pulley construction type listed in tables.

Type DF

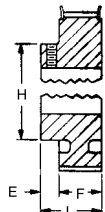

Type D

Type CF

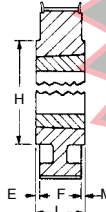

Type C

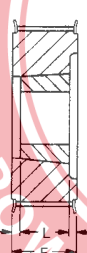

Type KF

Type AF

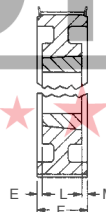

Type A



Type G



Type H

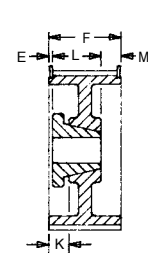

Type J

"F" designation in pulley type means pulley is flanged. When drive center distance is eight times the diameter of the smaller pulley or when drive is operating on vertical shafts, both pulleys should be flanged.

DEFINITION OF CATALOG NUMBERS

EX: TB 20L100

TB — Requires Taper Bushing

20 — Number of Teeth

L — 3/8" Pitch (Light)

100 — Belt Width 1"

EX: 72L100SD

72 — Number of Teeth

L — 3/8" Pitch (Light)

100 — Belt Width 1"

SD — Requires QD Bushing

EX: 16L100

Min. Plain Bore

Pulley Style Designation As Shown in Tables

Dash 1 = Block Body Style

Dash 2 = Web Style

Dash 3 = Arm/Spoke Style

Pulley sizes shown stocked as stock bore only: max. bore listed is without keyway. If keyway is used reduce max. bore by twice keyway depth.

1/5" Pitch Timing Pulleys | XL

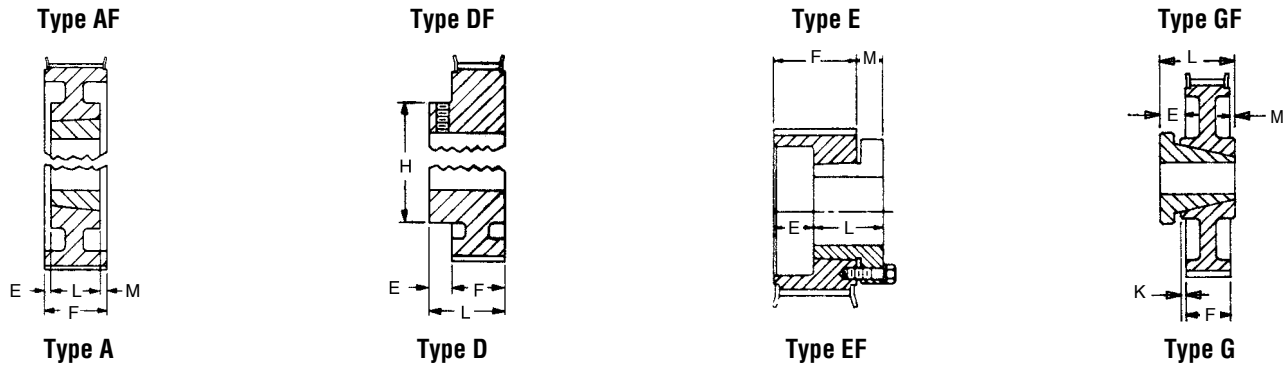

Dash 1 = Solid Style

Dash 2 = Web Style

Dash 3 = Arm/Spoke Style

"F" type description indicates flanged.

XL - 1/5" Pitch

XL 037 For Belts 1/4" and 3/8" Wide
Minimum Plain Bore

$$F = \frac{9}{16}$$

No. Teeth	Part Number	Pitch Diameter	Max FL O.D.	Type	Bore		E	H	L	WT
					Stk.	Max.				
10	10XL037	0.637	0.929	DF-1	3/16	1/4	7/32	7/16	5/32	0.03
11	11XL037	0.700	0.929	DF-1	3/16	1/4	7/32	7/16	5/32	0.04
12	12XL037	0.764	0.993	DF-1	3/16	5/16	7/32	1/2	5/32	0.06
14	14XL037	0.891	1.120	DF-1	1/4	3/8	7/32	9/16	5/32	0.08
15	15XL037	0.955	1.184	DF-1	1/4	7/16	7/32	9/16	5/32	0.09
16	16XL037	1.019	1.248	DF-1	1/4	1/2	7/32	1 1/16	5/32	0.10
18	18XL037	1.146	1.375	DF-1	1/4	9/16	7/32	1 1/16	5/32	0.13
20	20XL037	1.273	1.502	DF-1	1/4	1 1/16	5/16	1 5/16	7/8	0.18
21	21XL037	1.337	1.566	DF-1	1/4	1 1/16	5/16	1 5/16	7/8	0.19
22	22XL037	1.401	1.630	DF-1	3/8	3/4	5/16	1	7/8	0.22
24	24XL037	1.528	1.756	DF-1	3/8	13/16	5/16	1 1/16	7/8	0.25
28	28XL037	1.783	2.011	DF-1	1/2	15/16	5/16	1 3/16	7/8	0.34
30	30XL037	1.910	2.138	DF-1	5/16	1 1/16	5/16	1 3/8	7/8	0.41
32	32XL037	2.037	—	D-1	5/16	1 3/16	7/16	1 1/2	1	0.25
36	36XL037	2.292	—	D-1	5/16	1 3/16	7/16	1 1/2	1	0.29
40	40XL037	2.546	—	D-1	5/16	1 3/16	7/16	1 1/2	1	0.35
42	42XL037	2.674	—	D-1	5/16	1 3/16	7/16	1 1/2	1	0.31
44	44XL037	2.801	—	D-1	5/16	1 3/16	7/16	1 1/2	1	0.34
48	48XL037	3.056	—	D-1	5/16	1 3/16	7/16	1 1/2	1	0.63
60	60XL037	3.820	—	D-1	3/8	1 7/16	7/16	1 1/2	1	0.90
72	72XL037	4.584	—	D-1	3/8	1 7/16	7/16	1 1/2	1	0.50

Note: XL Pulleys stocked min. plain bore with 2 setscrews @ 90°. If keyway is used, reduce max. bore by twice keyway depth.
Pulley O.D. = P.D. - .02".

Every effort is made to keep all catalog dimensions and styles current in the catalog. However, from time to time it is necessary because of manufacturing changes to alter stock products dimensionally. If any stock product dimension or style in this catalog section is critical to your application please contact *Martin* for certification.

L | 3/8" Pitch Timing Pulleys

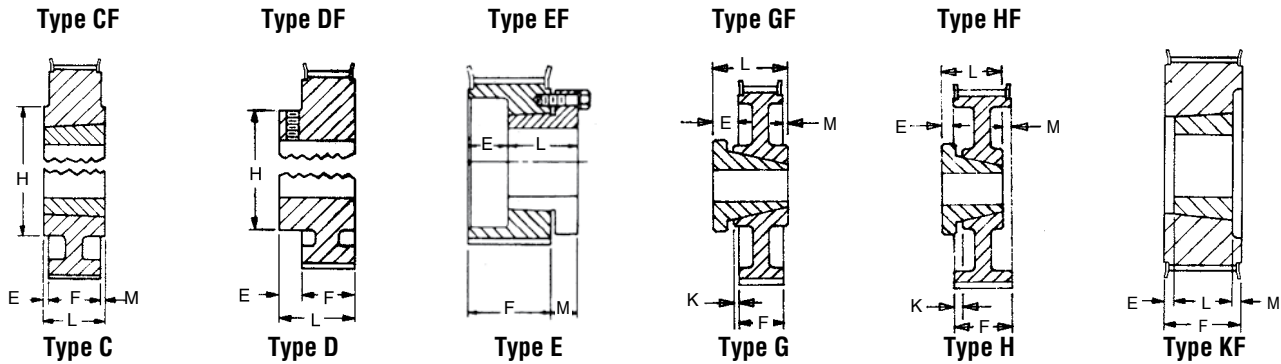

Dash 1 = Solid Style

Dash 2 = Web Style

Dash 3 = Arm/Spoke Style

L - 3/8" Pitch

L050 For Belts 1/2" Wide

Minimum Plain Bore

F = 3/4

No. Teeth	Part Number	Pitch Diameter	Max Fl. O.D.	Type	Bore		Dimensions			Wt.
					Stk.	Max.	E	H	L	
10	10L050	1.194	1 1/16	DF-1	3/8	3/16	3/8	1 3/16	1 1/8	0.28
12	12L050	1.432	1 3/64	DF-1	3/8	3/16	1/2	1 1/8	1 1/4	0.30
13	13L050	1.552	1 3/4	DF-1	3/8	3/16	1/2	1 1/8	1 1/4	0.35
14	14L050	1.671	1 5/64	DF-1	3/8	7/8	1/2	1 1/8	1 1/4	0.40
15	15L050	1.790	2	DF-1	1/2	3/16	1/2	1 1/8	1 1/4	0.50
16	16L050	1.910	2 2/32	DF-1	1/2	1 1/8	3/4	1 3/8	1 3/8	0.60
17	17L050	2.029	2 2/32	DF-1	1/2	1 1/8	3/4	1 3/8	1 3/8	0.65
18	18L050	2.149	2 25/64	DF-1	1/2	1 3/8	3/4	1 5/8	1 3/8	0.75
19	19L050	2.268	2 3/8	DF-1	1/2	1 3/8	3/4	1 5/8	1 3/8	0.80
20	20L050	2.387	2 3/8	DF-1	1/2	1 1/4	3/4	1 11/16	1 3/8	0.94
21	21L050	2.507	2 3/4	DF-1	1/2	1 5/8	3/4	1 7/8	1 3/8	1.00
22	22L050	2.626	2 7/8	DF-1	1/2	1 1/2	3/4	2	1 1/2	1.10
24	24L050	2.865	3 3/64	DF-1	1/2	1 5/8	3/4	2 1/4	1 1/2	1.60
26	26L050	3.104	3 11/32	DF-1	1/2	1 3/4	3/4	2 1/2	1 1/2	2.30
28	28L050	3.342	3 37/64	DF-1	1/2	1 3/4	3/4	2 3/4	1 1/2	2.50
30	30L050	3.581	3 59/64	DF-1	1/2	1 3/4	3/4	2 3/8	1 1/2	2.70
32	32L050	3.820	4 1/8	DF-1	1/2	1 3/8	3/4	3 1/16	1 3/8	3.00

L Pulleys 10 - 16 teeth min. plain bore stocked with 1 set screw. If keyway is used, reduced max. bore by twice keyway depth.
 Dimensions in inches. Weight in pounds
 Pulley O.D. = P.D. - .03"

L - 3/8" Pitch

L050 For Belts 1/2" Wide (3/8" Pitch)

QD Type

F = 3/4

No. Teeth	Part Number	Pitch Diameter	Max Fl. O.D.	Type	Bush	Bore Range	Dimensions				Wt. Less Bush.
							E	K	L	M	
18	18L050JA	2.149	2 25/64	EF-1*	JA	1/2-1 1/4	3/8	—	1 1/8	1/2	0.40
20	20L050JA	2.387	2 3/8	EF-1*	JA	1/2-1 1/4	3/8	—	1 1/8	1/2	0.50
22	22L050JA	2.626	2 7/8	EF-1*	JA	1/2-1 1/4	3/8	—	1 1/8	1/2	0.70
24	24L050SH	2.865	3 3/64	GF-1 +	SH	1/2-1 1/8	3/8	—	1 1/8	0	0.70
26	26L050SH	3.104	3 11/32	GF-1 +	SH	1/2-1 1/8	3/8	0	1 1/8	0	1.00
28	28L050SH	3.342	3 37/64	GF-1 +	SH	1/2-1 1/8	3/8	0	1 1/8	0	1.10
30	30L050SDS	3.581	3 59/64	GF-1	SDS	1/2-2	3/8	0	1 1/8	0	1.10
32	32L050SDS	3.820	4 1/8	GF-1	SDS	1/2-2	3/8	0	1 1/8	0	1.40
36	36L050SDS	4.297	4 7/32	GF-1	SDS	1/2-2	3/8	0	1 1/8	0	2.00
40	40L050SDS	4.775	5 5/64	GF-1	SDS	1/2-2	3/8	0	1 1/8	0	2.80
44	44L050SDS	5.252	5 31/64	GF-1	SDS	1/2-2	3/8	0	1 1/8	0	3.60
48	48L050SDS	5.730	6 3/64	GF-1	SDS	1/2-2	3/8	0	1 1/8	0	4.40
60	60L050SD	7.162	—	G-3	SD	1/2-2	3/8	1/4	1 1/8	1/4	4.20
72	72L050SD	8.594	—	G-3	SD	1/2-2	3/8	1/4	1 1/8	1/4	6.60
84	84L050SD	10.027	—	G-3	SD	1/2-2	3/8	1/4	1 1/8	1/4	5.80

Dimensions in inches. Weight in pounds
 Pulley O.D. = P.D. - .03"
 *Reverse mount drilled only
 +Bushing Projects 1/8 on Small End.

L050 Taper Bushed on Page K7

3/8" Pitch Timing Pulleys | L

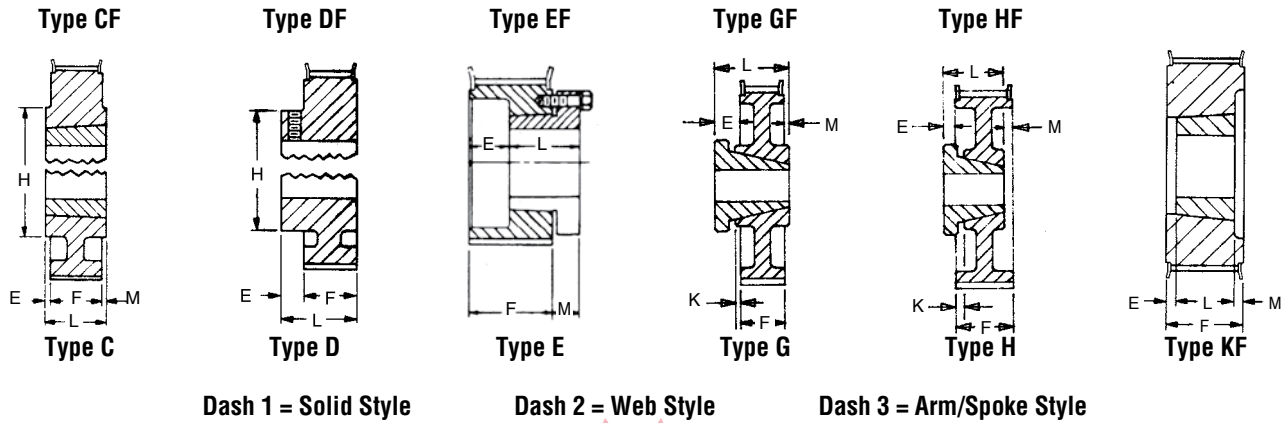

L - 3/8" Pitch

L050 For Belts 1/2" Wide (3/8" Pitch)

Taper Bushed Type

F = 3/4

No. Teeth	Part Number	Pitch Diameter	Max FL O.D.	Type	Bush	Bore Range	Dimensions			Wt. Less Bush.	
							E	H	L		M
18	TB18L050	2.149	2 ²⁵ / ₆₄	CF-1	1008	1/2-1	1/8	1 ¹ / ₁₆	3/8	—	0.45
20	TB20L050	2.387	2 ⁵ / ₈	CF-1	1008	1/2-1	1/8	1 ¹ / ₁₆	3/8	—	0.68
22	TB22L050	2.626	2 ⁷ / ₈	CF-1	1008	1/2-1	1/8	2	3/8	—	0.90
24	TB24L050	2.865	3 ¹ / ₆₄	CF-1	1210	1/2-1 ¹ / ₄	1/4	2 ¹ / ₄	1	—	1.00
26	TB26L050	3.104	3 ¹¹ / ₃₂	CF-1	1210	1/2-1 ¹ / ₄	1/4	2 ¹ / ₂	1	—	1.20
28	TB28L050	3.342	3 ³⁷ / ₆₄	CF-1	1610	1/2-1 ¹ / ₄	1/4	2 ³ / ₄	1	—	1.40
30	TB30L050	3.581	3 ⁵³ / ₆₄	CF-1	1610	1/2-1 ¹ / ₄	1/4	2 ⁷ / ₈	1	—	1.50
32	TB32L050	3.820	4 ¹ / ₁₆	CF-1	1610	1/2-1 ¹ / ₄	1/4	3 ¹ / ₁₆	1	—	1.90
40	TB40L050	4.775	5 ⁵ / ₆₄	CF-1	2012	1/2-2	1/2	3 ¹¹ / ₁₆	1 ¹ / ₄	—	2.40
48	TB48L050	5.730	6 ³ / ₆₄	CF-1	2012	1/2-2	1/2	3 ¹¹ / ₁₆	1 ¹ / ₄	—	3.20
60	TB60L050	7.162	—	C-2	2012	1/2-2	1/4	4 ³ / ₈	1 ¹ / ₄	1/4	4.90

Dimensions in inches. Weight in pounds
Pulley O.D. = P.D. - .03"

L - 3/8" Pitch

L075 For Belts 3/4" Wide (3/8" Pitch)

Minimum Plain Bore

F = 1

No. Teeth	Part Number	Pitch Diameter	Max FL O.D.	Type	Bore		Dimensions			Wt.
					Stk.	Max.	E	H	L	
12	12L075	1.432	1 ⁴³ / ₆₄	DF-1	3/8	1 ³ / ₁₆	1/2	1 ¹ / ₁₆	1 ¹ / ₂	0.40
14	14L075	1.671	1 ⁵⁹ / ₆₄	DF-1	3/8	7/8	1/2	1 ¹ / ₈	1 ¹ / ₂	0.50
16	16L075	1.910	2 ⁷ / ₃₂	DF-1	1/2	1 ¹ / ₈	5/8	1 ⁷ / ₁₆	1 ¹ / ₂	0.70
18	18L075	2.149	2 ²⁵ / ₆₄	DF-1	1/2	1 ¹ / ₈	5/8	1 ¹ / ₈	1 ¹ / ₂	0.90
20	20L075	2.387	2 ⁵ / ₈	DF-1	1/2	1 ¹ / ₄	5/8	1 ¹ / ₁₆	1 ¹ / ₂	1.50
22	22L075	2.626	2 ⁷ / ₈	DF-1	5/8	1 ¹ / ₂	3/4	2	1 ³ / ₄	1.80
24	24L075	2.865	3 ¹ / ₆₄	DF-1	5/8	1 ¹ / ₈	3/4	2 ¹ / ₄	1 ³ / ₄	2.10
26	26L075	3.104	3 ¹¹ / ₃₂	DF-1	5/8	1 ¹ / ₈	7/8	2 ¹ / ₂	1 ¹ / ₂	2.80
28	28L075	3.342	3 ³⁷ / ₆₄	DF-1	5/8	1 ¹ / ₈	1	2 ³ / ₄	2	3.10
30	30L075	3.581	3 ⁵³ / ₆₄	DF-1	5/8	1 ¹ / ₈	1	2 ⁷ / ₈	2	3.40
32	32L075	3.820	4 ¹ / ₁₆	DF-1	5/8	1 ¹ / ₈	1	3 ¹ / ₁₆	2	3.70

Dimensions in inches. Weight in pounds.
Pulley O.D. = P.D. - .03"

L Pulleys 12 - 16 teeth min. plain bore stocked with 1-SS. If keyway is used, reduce max. bore by twice keyway depth.

L | 3/8" Pitch Timing Pulleys

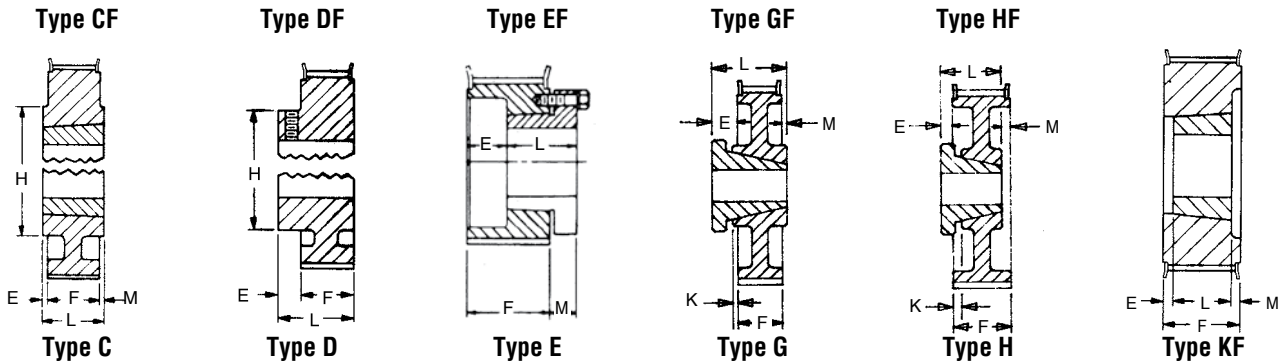

Dash 1 = Solid Style

Dash 2 = Web Style

Dash 3 = Arm/Spoke Style

L - 3/8" Pitch

L075 For Belts 3/4" Wide (3/8" Pitch)

QD Type

F = 1

No. Teeth	Part Number	Pitch Diameter	Max FL O.D.	Type	Bush	Bore Range	Dimensions				Wt. Less Bush.
							E	K	L	M	
18	18L075JA	2.149	2 ^{23/64}	EF-1*	JA	1/2 - 1/4	3/16	—	1 ^{1/16}	1/2	0.50
20	20L075JA	2.387	2 ^{3/8}	EF-1*	JA	1/2 - 1/4	3/16	—	1 ^{1/16}	1/2	0.70
22	22L075JA	2.626	2 ^{7/8}	EF-1*	JA	1/2 - 1/4	3/16	—	1 ^{1/16}	1/2	0.80
24	24L075SH	2.865	3 ^{1/4}	EF-1*	SH	1/2 - 1 ^{1/16}	3/16	—	1 ^{1/16}	5/8	0.80
26	26L075SH	3.104	3 ^{11/32}	EF-1*	SH	1/2 - 1 ^{1/16}	3/16	—	1 ^{1/16}	5/8	1.10
28	28L075SH	3.342	3 ^{37/64}	EF-1*	SH	1/2 - 1 ^{1/16}	3/16	—	1 ^{1/16}	5/8	1.30
30	30L075SDS	3.581	3 ^{59/64}	EF-1*	SDS	1/2 - 2	1/4	—	1 ^{1/16}	5/8	1.50
32	32L075SDS	3.820	4 ^{1/16}	EF-1*	SDS	1/2 - 2	1/4	—	1 ^{1/16}	5/8	1.70
36	36L075SDS	4.297	4 ^{17/32}	HF-1	SDS	1/2 - 2	3/8	1/4	1 ^{1/16}	0	2.30
40	40L075SDS	4.775	5 ^{1/64}	HF-1	SDS	1/2 - 2	3/8	1/4	1 ^{1/16}	0	3.10
44	44L075SDS	5.252	5 ^{57/64}	HF-1	SDS	1/2 - 2	3/8	1/4	1 ^{1/16}	0	4.00
48	48L075SDS	5.730	6 ^{1/64}	HF-1	SDS	1/2 - 2	3/8	1/4	1 ^{1/16}	0	4.60
60	60L075SD	7.162	—	G-3	SD	1/2 - 2	1 ^{1/16}	1/8	1 ^{13/16}	1/8	4.70
72	72L075SD	8.594	—	G-3	SD	1/2 - 2	1 ^{11/16}	1/8	1 ^{13/16}	1/8	6.50
84	84L075SD	10.027	—	G-3	SD	1/2 - 2	1 ^{11/16}	1/8	1 ^{13/16}	1/8	6.30

Dimensions in inches. Weight in pounds

Pulley O.D. = P.D. - .03"

*Reverse mount only

L - 3/8" Pitch

L075 For Belts 3/4" Wide (3/8" Pitch)

Taper Bushed Type

F = 1

No. Teeth	Part Number	Pitch Diameter	Max FL O.D.	Type	Bush	Bore Range	Dimensions				Wt. Less Bush.
							E	H	L	M	
18	TB18L075	2.149	2 ^{-25/64}	KF-1	1008	1/2 - 1	1/8	—	7/8	—	0.50
20	TB20L075	2.387	2 ^{-3/8}	KF-1	1008	1/2 - 1	1/8	—	7/8	—	0.70
22	TB22L075	2.626	2 ^{-7/8}	KF-1	1008	1/2 - 1	1/8	—	7/8	—	1.10
24	TB24L075	2.865	3 ^{-1/64}	KF-1	1210	1/2 - 1-1/4	—	—	1	—	0.90
26	TB26L075	3.104	3 ^{-11/32}	KF-1	1210	1/2 - 1-1/4	—	—	1	—	1.30
28	TB28L075	3.342	3 ^{-27/64}	KF-1	1610	1/2 - 1-3/8	—	—	1	—	1.30
30	TB30L075	3.581	3 ^{-23/64}	KF-1	1610	1/2 - 1-3/8	—	—	1	—	1.60
32	TB32L075	3.820	4 ^{-1/16}	KF-1	1610	1/2 - 1-3/8	—	—	1	—	1.80
40	TB40L075	4.775	5 ^{-1/64}	CF-1	2012	1/2 - 2	1/4	3 ^{-19/16}	1-1/4	—	3.60
48	TB48L075	5.730	6 ^{-1/64}	CF-1	2012	1/2 - 2	1/4	3 ^{-15/16}	1-1/4	—	5.40
60	TB60L075	7.162	—	C-1	2012	1/2 - 2	1/8	4 ^{-3/8}	1-1/4	1/8	7.90

Dimensions in inches. Weight in pounds

Pulley O.D. = P.D. - .03"

3/8" Pitch Timing Pulleys | L

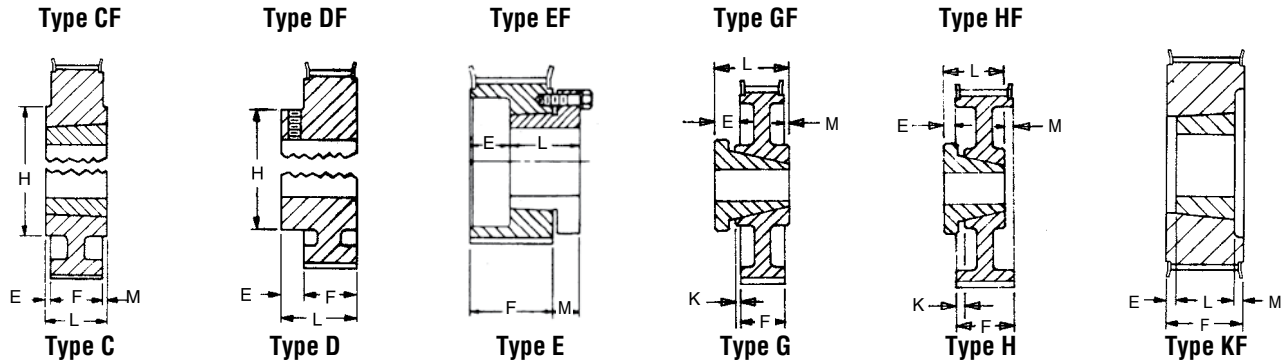

Dash 1 = Solid Style

Dash 2 = Web Style

Dash 3 = Arm/Spoke Style

L - 3/8" Pitch

L100 For Belts 1" Wide (3/8" Pitch)

Minimum Plain Bore

F = 1 1/4

No. Teeth	Part Number	Pitch Diameter	Max FL O.D.	Type	Bore		Dimensions			Wt.
					Stk.	Max.	E	H	L	
14	14L100	1.671	1 ⁵⁹ / ₆₄	DF-1	3/8	7/8	1/2	1 1/8	1 1/4	0.60
16	16L100	1.910	2 ⁷ / ₃₂	DF-1	1/2	1 1/8	5/8	1 1/8	1 1/4	0.80
17	17L100	2.029	2 ⁷ / ₃₂	DF-1	1/2	1 1/8	5/8	1 1/2	1 1/4	1.00
18	18L100	2.149	2 ²⁵ / ₆₄	DF-1	1/2	1 1/8	5/8	1 1/8	1 1/4	1.10
19	19L100	2.268	2 ⁷ / ₁₆	DF-1	1/2	1 1/8	5/8	1 1/8	1 1/4	1.40
20	20L100	2.387	2 ⁵ / ₈	DF-1	1/2	1 1/8	5/8	1 11/16	1 1/8	1.75
21	21L100	2.507	2 ³ / ₄	DF-1	5/8	1 1/8	11/16	1 1/8	1 1/8	1.80
22	22L100	2.626	2 ⁷ / ₈	DF-1	5/8	1 1/2	3/4	2	2	2.00
24	24L100	2.865	3 ⁷ / ₆₄	DF-1	3/4	1 1/8	3/4	2 1/4	2	2.50
26	26L100	3.104	3 ¹ / ₃₂	DF-1	3/4	1 1/8	7/8	2 1/2	2 1/8	3.30
28	28L100	3.342	3 ³⁷ / ₆₄	DF-1	5/8	1 1/8	1	2 1/4	2 1/4	3.60
30	30L100	3.581	3 ³ / ₁₆	DF-1	5/8	1 1/8	1	2 1/2	2 1/4	4.00
32	32L100	3.820	4 ¹ / ₁₆	DF-1	5/8	1 1/8	1	3 1/16	2 1/4	4.40

Dimensions in inches. Weight in pounds

Pulley O.D. = P.D. - .03"

L Pulleys 14 - 16 teeth min. plain bore stocked with 1-S.S. If keyway is used, reduce max. bore by twice keyway depth.

L - 3/8" Pitch

L100 For Belts 1" Wide (3/8" Pitch)

QD Type

F = 1 1/4

No. Teeth	Part Number	Pitch Diameter	Max FL O.D.	Type	Bush	Bore Range	Dimensions				Wt. Less Bush.
							E	K	L	M	
18	18L100JA	2.149	2 ²⁵ / ₆₄	EF-1*	JA	1/2 - 1 1/4	1 1/16	—	1 1/16	1/2	0.70
20	20L100JA	2.387	2 ⁵ / ₈	EF-1*	JA	1/2 - 1 1/4	1 1/16	—	1 1/16	1/2	0.90
22	22L100JA	2.626	2 ⁷ / ₈	EF-1*	JA	1/2 - 1 1/4	1 1/16	—	1 1/16	1/2	1.00
24	24L100SH	2.865	3 ⁷ / ₆₄	EF-1*	SH	1/2 - 1 11/16	7/16	—	1 1/16	3/16	1.00
26	26L100SH	3.104	3 ¹ / ₃₂	EF-1*	SH	1/2 - 1 11/16	7/16	—	1 5/16	3/16	1.30
28	28L100SH	3.342	3 ³⁷ / ₆₄	EF-1*	SH	1/2 - 1 11/16	7/16	—	1 5/16	3/16	1.70
30	30L100SDS	3.581	3 ³ / ₁₆	EF-1*	SDS	1/2 - 2	1/2	—	1 5/8	5/8	2.00
32	32L100SDS	3.820	4 ¹ / ₁₆	EF-1*	SDS	1/2 - 2	1/2	—	1 5/8	5/8	2.10
36	36L100SDS	4.297	4 ¹ / ₃₂	HF-1	SDS	1/2 - 2	1/2	1/2	1 3/8	0	2.60
40	40L100SDS	4.775	5 ¹ / ₆₄	HF-1	SDS	1/2 - 2	1/2	1/2	1 3/8	0	3.40
44	44L100SDS	5.252	5 ⁹ / ₆₄	HF-1	SDS	1/2 - 2	1/2	1/2	1 3/8	0	4.20
48	48L100SDS	5.730	6 ¹ / ₆₄	HF-1	SDS	1/2 - 2	1/2	1/2	1 3/8	0	5.10
60	60L100SD	7.162	—	G-3	SD	1/2 - 2	5/8	0	1 3/16	0	6.00
72	72L100SD	8.594	—	G-3	SD	1/2 - 2	5/8	0	1 3/16	0	8.00
84	84L100SD	10.027	—	G-3	SD	1/2 - 2	5/8	0	1 3/16	0	9.20

Dimensions in inches. Weight in pounds

Pulley O.D. = P.D. - .03"

*Reverse mount only

L | 3/8" Pitch Timing Pulleys

Type CF

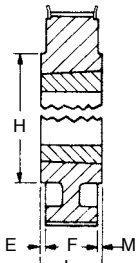

Type C

Type DF

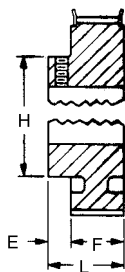

Type D

Type EF

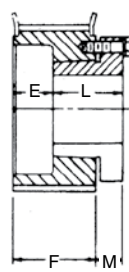

Type E

Type GF

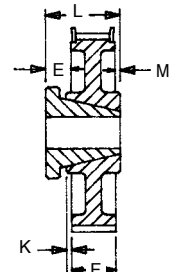

Type G

Dash 1 = Solid Style

Dash 2 = Web Style

Dash 3 = Arm/Spoke Style

"F" in type description indicates flanged.

Type HF

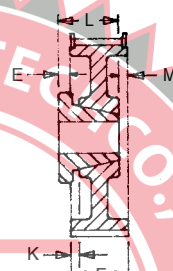

Type H

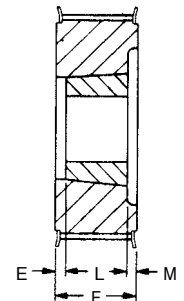

Type KF

L - 3/8" Pitch

L100 For Belts 1" Wide (3/8" Pitch)

Taper Bushed Type

F = 1 1/4

No. Teeth	Part Number	Pitch Diameter	Max. FL. O.D.	Type	Bush	Bore Range	Dimensions				Wt. Less Bush.
							E	K	L	M	
18	TB18L100	2.149	2 ⁵ / ₆₄	KF-1	1008	1/2 - 1	3/8	—	7/8	—	0.70
20	TB20L100	2.387	2 ⁵ / ₆₄	KF-1	1008	1/2 - 1	3/8	—	7/8	—	1.00
22	TB22L100	2.626	2 ⁵ / ₆₄	KF-1	1008	1/2 - 1	3/8	—	7/8	—	1.30
24	TB24L100	2.865	3 ³ / ₆₄	KF-1	1210	1/2 - 1 1/4	1/4	—	1	—	1.30
26	TB26L100	3.104	3 ¹¹ / ₆₄	KF-1	1210	1/2 - 1 1/4	1/4	—	1	—	1.70
28	TB28L100	3.342	3 ³⁷ / ₆₄	KF-1	1610	1/2 - 1 1/2	1/4	—	1	—	1.70
30	TB30L100	3.581	3 ⁵³ / ₆₄	KF-1	1610	1/2 - 1 1/2	1/4	—	1	—	2.20
32	TB32L100	3.820	4 ¹ / ₁₆	KF-1	1610	1/2 - 1 1/2	1/4	—	1	—	2.70
40	TB40L100	4.775	5 ⁵ / ₆₄	KF-1	2012	1/2 - 2	1/16	—	1 1/4	—	3.60
48	TB48L100	5.730	6 ⁵ / ₆₄	KF-1	2012	1/2 - 2	1/16	—	1 1/4	—	5.10
60	TB60L100	7.162	—	C-2	2012	1/2 - 2	—	—	1 1/4	—	6.00

Dimensions in inches. Weight in pounds
Pulley O.D. = P.D. - .03"

1/2" Pitch Timing Pulleys | H

Type DF

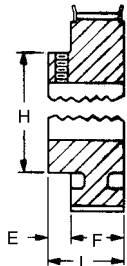

Type D

Type EF

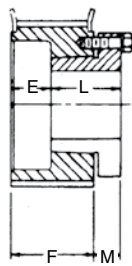

Type E

Type GF

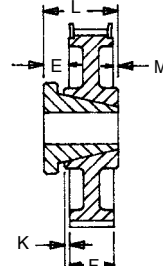

Type G

Type HF

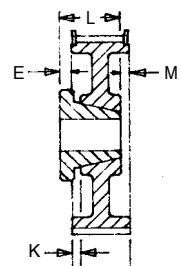

Type H

H — 1/2" Pitch

H100 For Belts 3/4" and 1" Wide (1/2" Pitch)

Minimum Plain Bore

F = 1 5/16

No. Teeth	Part Number	Pitch Diameter	Max FL. O.D.	Type	Bore		Dimensions			Wt.
					Stk.	Max.	E	H	L	
14	14H100	2.228	2 3/64	DF-1	5/8	1	5/8	1 1/2	1 15/16	1.4
16	16H100	2.546	2 5/64	DF-1	5/8	1 1/4	1 1/8	2	2	2.0
18	18H100	2.865	3 3/64	DF-1	5/8	1 1/2	1 1/8	2 1/4	2	2.8
20	20H100	3.183	3 7/64	DF-1	5/8	1 5/8	7/8	2 1/2	2 3/8	3.4
21	21H100	3.342	3 9/64	DF-1	3/4	1 11/16	1	2 5/8	2 1/2	3.8
22	22H100	3.501	3 3/4	DF-1	3/4	1 5/8	1	2 5/8	2 5/8	4.3
24	24H100	3.820	4 1/64	DF-1	3/4	2	1	3	2 5/8	5.3
26	26H100	4.138	4 5/64	DF-1	3/4	2 1/2	1-1/8	3 1/2	2 5/8	6.7
28	28H100	4.456	4 9/64	DF-1	3/4	2 5/8	1-1/8	3 3/8	2 5/8	8.0

Dimensions in inches. Weight in pounds
Pulley O.D. = P.D. - .054"

H — 1/2" Pitch

H100 For Belts 3/4" and 1" Wide (1/2" Pitch)

QD Type

F = 1 5/16

No. Teeth	Part Number	Pitch Diameter	Max FL. O.D.	Type	Bush	Bore Range	Dimensions				Wt. Less Bush.	
							E	H	K	L		M
14	14H100JA	2.228	2 3/64	EF-1*	JA	1/2 - 1 1/4	3/4	—	—	1 1/8	1/2	1.0
16	16H100JA	2.546	2 5/64	EF-1*	JA	1/2 - 1 1/4	3/4	—	—	1 1/8	1/2	1.5
18	18H100SH	2.865	3 3/64	EF-1*	SH	1/2 - 1 11/16	3/4	—	—	1 1/8	3/8	1.2
20	20H100SH	3.183	3 7/64	EF-1*	SH	1/2 - 1 11/16	3/4	—	—	1 1/8	3/8	1.2
22	22H100SDS	3.501	3 3/4	EF-1*	SDS	1/2 - 2	3/4	—	—	1 1/8	5/8	1.4
24	24H100SDS	3.820	4 1/64	EF-1*	SDS	1/2 - 2	3/4	—	—	1 3/8	5/8	1.7
26	26H100SDS	4.138	4 5/64	HF-1	SDS	1/2 - 2	3/4	—	3/8	1 3/8	—	2.0
28	28H100SDS	4.456	4 9/64	HF-1	SDS	1/2 - 2	3/4	—	3/8	1 3/8	—	2.6
30	30H100SD	4.775	5 1/64	GF-1	SD	1/2 - 2	5/8	—	—	1 13/16	—	3.0
32	32H100SK	5.093	5 5/64	GF-1	SK	1/2 - 2 3/8	1 1/8	—	—	1 15/16	—	4.9
36	36H100SK	5.730	5 9/64	GF-1	SK	1/2 - 2 3/8	1 1/8	—	—	1 15/16	—	5.6
40	40H100SK	6.366	6 3/64	GF-1	SK	1/2 - 2 3/8	1 1/8	—	—	1 15/16	—	8.2
44	44H100SK	7.003	7 1/4	GF-1	SK	1/2 - 2 3/8	1 1/8	—	—	1 15/16	—	10.0
48	48H100SK	7.639	8 1/64	GF-2	SK	1/2 - 2 3/8	1 1/8	—	—	1 15/16	—	12.5
60	60H100SF	9.549	—	H-2	SF	1/2 - 2 15/16	1 1/8	—	—	2 1/8	—	10.9
72	72H100SF	11.459	—	H-3	SF	1/2 - 2 15/16	1 1/8	—	—	2 1/8	—	14.0
84	84H100SF	13.369	—	H-3	SF	1/2 - 2 15/16	1 1/8	5 1/8	—	2 1/8	—	20.0
96	96H100SF	15.279	—	H-3	SF	1/2 - 2 15/16	1 1/8	5 1/8	—	2 1/8	—	27.0
120	120H100SF	19.099	—	H-3	SF	1/2 - 2 15/16	1 1/8	5 1/8	—	2 1/8	—	38.0

Dimensions in inches. Weight in pounds
Pulley O.D. = P.D. - .054"

*Reverse mount only

H | 1/2" Pitch Timing Pulleys

Type CF

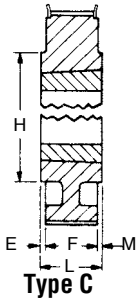

Type C

Type DF

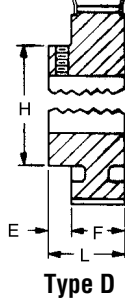

Type D

Type EF

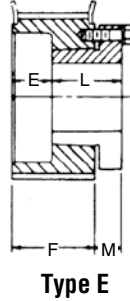

Type E

Type GF

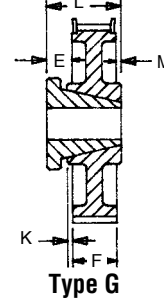

Type G

Type HF

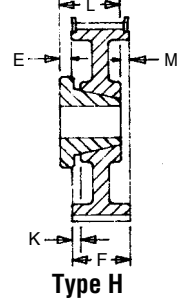

Type H

Dash 1 = Solid Style

Dash 2 = Web Style

Dash 3 = Arm/Spoke Style

"F" in description indicates flanged.

H — 1/2" Pitch

H100 For Belts 3/4" and 1" Wide (1/2" Pitch)

Taper Bushed Type

F = 1 1/16

No. Teeth	Part Number	Pitch Diameter	Max FL. O.D.	Type	Bush	Bore Range	Dimensions				Wt. Less Bush.
							E	H	L	M	
14	TB14H100	2.228	2 5/64	KF-1	1008	1/2 - 1	7/16	—	7/8	—	0.80
16	TB16H100	2.546	2 5/64	KF-1	1008	1/2 - 1	7/16	—	7/8	—	1.30
18	TB18H100	2.865	3 3/64	KF-1	1210	1/2 - 1 1/4	5/16	—	1	—	1.20
20	TB20H100	3.183	3 3/16	KF-1	1210	1/2 - 1 1/4	5/16	—	1	—	1.70
22	TB22H100	3.501	3 3/4	KF-1	1610	1/2 - 1 1/2	5/16	—	1	—	1.80
24	TB24H100	3.820	4 1/4	KF-1	1610	1/2 - 1 1/2	5/16	—	1	—	2.30
26	TB26H100	4.138	4 35/64	KF-1	2012	1/2 - 2	1/16	—	1 1/4	—	2.60
28	TB28H100	4.456	4 45/64	KF-1	2012	1/2 - 2	1/16	—	1 1/4	—	2.80
30	TB30H100	4.775	5 1/64	KF-1	2012	1/2 - 2	1/16	—	1 1/4	—	4.20
32	TB32H100	5.093	5 21/64	CF-1	2517	1/2 - 2 1/2	7/16	4 7/16	1 1/4	—	4.30
40	TB40H100	6.366	6 37/64	CF-1	2517	1/2 - 2 1/2	7/16	4 7/16	1 1/4	—	7.80
48	TB48H100	7.639	8 1/4	CF-1	2517	1/2 - 2 1/2	7/16	4 7/16	1 1/4	—	12.10
60	TB60H100	9.549	—	C-2	3020	7/8 - 3	1 1/32	6 1/4	2	1 1/32	10.30

Dimensions in inches. Weight in pounds
Pulley O.D. = P.D. - .054"

1/2" Pitch Timing Pulleys | H

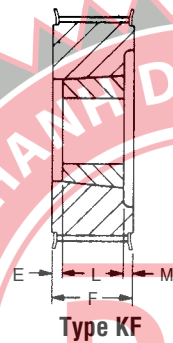
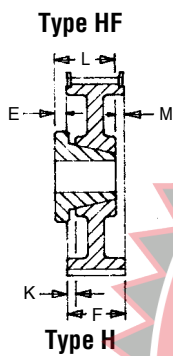
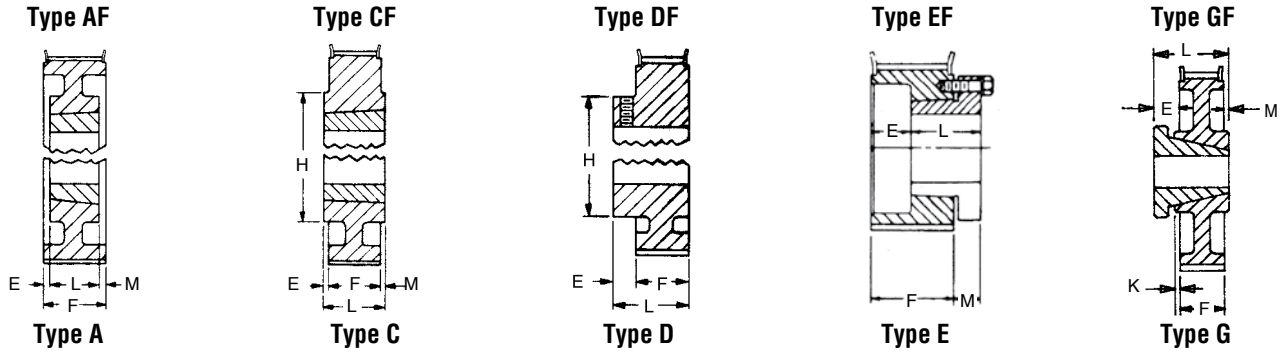

Dash 1 = Solid Style

Dash 2 = Web Style

Dash 3 = Arm/Spoke Style

"F" in type description indicates flanged.

H — 1/2" Pitch

H150 For Belts 1 1/2" Wide (1/2" Pitch)

Minimum Plain Bore

F = 1 13/16

No. Teeth	Part Number	Pitch Diameter	Max Fl. O.D.	Type	Bore		Dimensions			Wt.
					Stk.	Max.	E	H	L	
14	14H150	2.228	2 ³¹ / ₆₄	DF-1	3/4	1	5/8	1 1/2	2 ⁷ / ₁₆	1.8
16	16H150	2.546	2 ⁵¹ / ₆₄	DF-1	3/4	1 1/4	3/4	2	2 ⁹ / ₁₆	2.5
18	18H150	2.865	3 ¹ / ₄	DF-1	3/4	1 1/2	3/4	2 1/4	2 ⁹ / ₁₆	3.3
19	19H150	3.024	3 ³ / ₄	DF-1	3/4	1 ⁹ / ₁₆	7/8	2 1/4	2 ⁹ / ₁₆	3.9
20	20H150	3.183	3 ⁷ / ₁₆	DF-1	3/4	1 ⁵ / ₈	7/8	2 1/2	2 ¹¹ / ₁₆	4.3
21	21H150	3.342	3 ⁹ / ₁₆	DF-1	3/4	1 ¹³ / ₁₆	1 ⁵ / ₁₆	2 1/2	2 ³ / ₄	5.3
22	22H150	3.501	3 ¹¹ / ₁₆	DF-1	3/4	1 ⁷ / ₈	1	2 ⁷ / ₁₆	2 ¹⁵ / ₁₆	5.4
24	24H150	3.820	4 ¹ / ₁₆	DF-1	3/4	2 ¹ / ₈	1	3 ¹ / ₈	2 ¹³ / ₁₆	6.5
26	26H150	4.138	4 ²⁵ / ₃₂	DF-1	3/4	2 ¹ / ₂	1	3 ¹ / ₂	2 ¹³ / ₁₆	8.4

Dimensions in inches. Weight in pounds
Pulley O.D. = P.D. - .054"

H | 1/2" Pitch Timing Pulleys

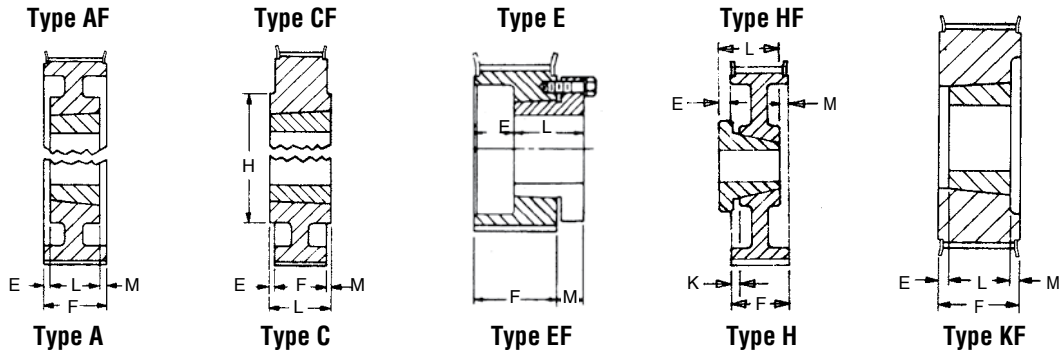

Dash 1 = Solid Style Dash 2 = Web Style Dash 3 = Arm/Spoke Style

"F" in type description indicates flanged.

H — 1/2" Pitch

H150 For Belts 1 1/2" Wide (1/2" Pitch)

QD Type

F = 1 19/16

No. Teeth	Part Number	Pitch Diameter	Max FL O.D.	Type	Bush.	Bore Range	Dimensions				Wt. Less Bush.
							E	K	L	M	
14	14H150JA	2.228	2 ^{31/64}	EF-1*	JA	1/2 - 1 1/4	1 1/4	—	1 1/16	1/2	1.5
16	16H150JA	2.546	2 ^{51/64}	EF-1*	JA	1/2 - 1 1/4	1 1/4	—	1 1/16	1/2	2.0
18	18H150SH	2.865	3 ^{3/64}	EF-1*	SH	1/2 - 1 11/16	1	—	1 1/16	3/16	1.3
20	20H150SH	3.183	3 ^{7/16}	EF-1*	SH	1/2 - 1 11/16	1	—	1 1/16	3/16	1.8
22	22H150SD	3.501	3 ^{1/4}	EF-1*	SD	1/2 - 2	3/8	—	1 13/16	3/8	2.0
24	24H150SD	3.820	4 ^{1/16}	EF-1*	SD	1/2 - 2	3/8	—	1 13/16	3/8	2.6
26	26H150SD	4.138	4 ^{25/32}	HF-1	SD	1/2 - 2	3/8	—	1 13/16	3/16	3.0
28	28H150SD	4.456	4 ^{45/64}	HF-1	SD	1/2 - 2	3/8	3/16	1 13/16	3/16	4.0
30	30H150SD	4.775	5 ^{1/64}	HF-1	SD	1/2 - 2	3/8	3/16	1 13/16	3/16	4.9
32	32H150SK	5.093	5 ^{21/64}	HF-1	SK	1/2 - 2 1/2	3/8	3/16	1 15/16	0	5.8
36	36H150SK	5.730	5 ^{61/64}	HF-1	SK	1/2 - 2 1/2	3/8	3/16	1 15/16	0	7.0
40	40H150SK	6.366	6 ^{37/64}	HF-1	SK	1/2 - 2 1/2	3/8	3/16	1 15/16	0	9.2
44	44H150SK	7.003	7 ^{1/4}	HF-1	SK	1/2 - 2 1/2	3/8	3/16	1 15/16	0	11.0
48	48H150SK	7.639	8 ^{3/64}	HF-2	SK	1/2 - 2 1/2	3/8	3/16	1 15/16	0	13.7
60	60H150SF	9.549	—	H-2	SF	1/2 - 2 15/16	13/32	9/32	2 1/16	9/32	12.5
72	72H150SF	11.459	—	H-3	SF	1/2 - 2 15/16	13/32	9/32	2 1/16	9/32	17.0
84	84H150SF	13.369	—	H-3	SF	1/2 - 2 15/16	13/32	9/32	2 1/16	9/32	21.5
96	96H150SF	15.279	—	H-3	SF	1/2 - 2 15/16	13/32	9/32	2 1/16	9/32	31.0
120	120H150SF	19.099	—	H-3	SF	1/2 - 2 15/16	13/32	9/32	2 1/16	9/32	40.0

Dimensions in inches. Weight in pounds

Pulley O.D. = P.D. - .054"

*Reverse mount only

H — 1/2" Pitch

H150 For Belts 1 1/2" Wide (1/2" Pitch)

Taper Bushed Type

F = 1 19/16

No. Teeth	Part Number	Pitch Diameter	Max FL O.D.	Type	Bush	Bore Range	Dimensions					Wt. Less Bush.
							E	H	K	L	M	
14	TB14H150	2.228	2 ^{31/64}	KF-1	1008	1/2 - 1	15/32	—	—	7/8	1 1/32	1.0
16	TB16H150	2.546	2 ^{51/64}	KF-1	1008	1/2 - 1	15/32	—	—	7/8	1 1/32	1.5
18	TB18H150	2.865	3 ^{3/64}	KF-1	1215	1/2 - 1 1/4	3/16	—	—	1 1/2	—	1.6
20	TB20H150	3.183	3 ^{7/16}	KF-1	1215	1/2 - 1 1/4	3/16	—	—	1 1/2	—	2.2
22	TB22H150	3.501	3 ^{1/4}	KF-1	1615	1/2 - 1 1/2	3/16	—	—	1 1/2	—	2.5
24	TB24H150	3.820	4 ^{1/16}	KF-1	2012	1/2 - 2	3/16	—	—	1 1/4	—	2.7
26	TB26H150	4.138	4 ^{25/32}	KF-1	2012	1/2 - 2	3/16	—	—	1 1/4	—	3.2
28	TB28H150	4.456	4 ^{45/64}	KF-1	2012	1/2 - 2	3/16	—	—	1 1/4	—	4.1
30	TB30H150	4.775	5 ^{1/64}	KF-1	2012	1/2 - 2	3/16	—	—	1 1/4	—	5.1
32	TB32H150	5.093	5 ^{21/64}	KF-1	2517	1/2 - 2 1/2	3/16	—	—	1 3/4	—	5.6
40	TB40H150	6.366	6 ^{37/64}	KF-1	2517	1/2 - 2 1/2	3/16	—	—	1 3/4	—	8.6
48	TB48H150	7.639	8 ^{3/64}	AF-1	2517	1/2 - 2 1/2	—	—	3/16	1 3/4	3/16	13.6
60	TB60H150	9.549	—	C-2	3020	7/8 - 3	3/32	6-1/4	—	2	3/32	12.3

Dimensions in inches. Weight in pounds

Pulley O.D. = P.D. - .054"

1/2" Pitch Timing Pulleys | H

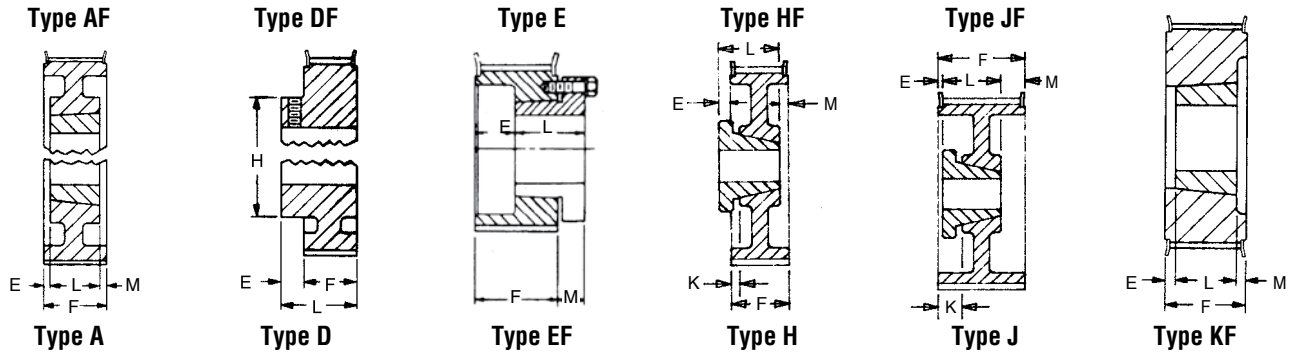

Dash 1 = Solid Style Dash 2 = Web Style Dash 3 = Arm/Spoke Style

"F" in type description indicates flanged.

H — 1/2" Pitch

H200 For Belts 2" Wide (1/2" Pitch)

Minimum Plain Bore

F = 2-11/32

No. Teeth	Part Number	Pitch Diameter	Max FL O.D.	Type	Bore		E	Dimensions		Wt.
					Stk.	Max.		H	L	
14	14H200	2.228	2 3/8	DF-1	3/4	1	5/8	1 1/2	2 31/32	2.2
16	16H200	2.546	2 51/64	DF-1	3/4	1 1/4	3/4	2	3 3/32	3.1
18	18H200	2.865	3 3/64	DF-1	3/4	1 1/2	3/4	2	3 3/32	3.7
19	19H200	3.024	3 1/4	DF-1	3/4	1 5/8	7/8	2 1/4	3 3/32	3.9
20	20H200	3.183	3 7/16	DF-1	3/4	1 5/8	7/8	2 1/2	3 3/32	4.9
22	22H200	3.501	3 3/4	DF-1	1	1 7/8	1	2 3/8	3 11/32	6.3
24	24H200	3.820	4 1/16	DF-1	1	2 1/8	1	3 1/8	3 11/32	7.5
26	26H200	4.138	4 7/32	DF-1	1	2 1/2	1-1/8	3 1/2	3 11/32	9.5

Dimensions in inches. Weight in pounds
Pulley O.D. = P.D. - .054"

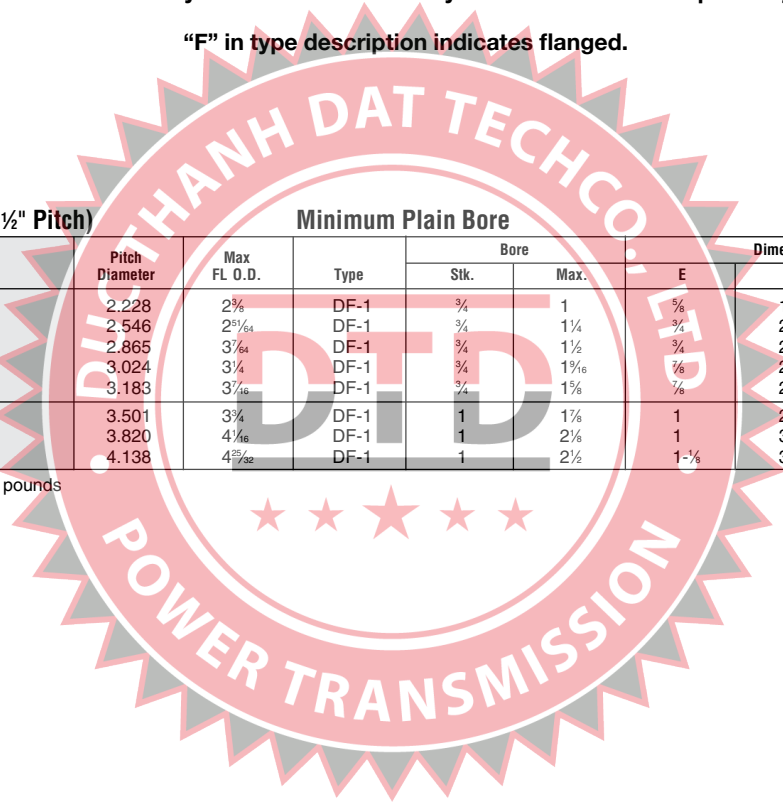

H | 1/2" Pitch Timing Pulleys

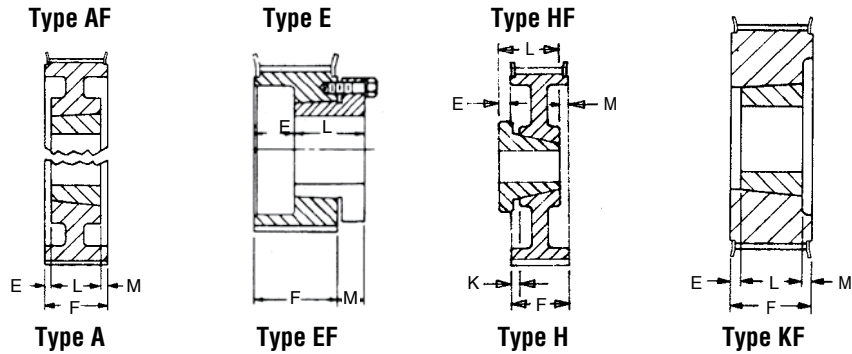

Dash 1 = Solid Style Dash 2 = Web Style Dash 3 = Arm/Spoke Style

"F" in type description indicates flanged.

H — 1/2" Pitch

H200 For Belts 2" Wide (1/2" Pitch)

QD Type

F = 2-1/32

No. Teeth	Part Number	Pitch Diameter	Max. FL. O.D.	Type	Bush	Bore Range	Dimensions			Wt. Less Bush.	
							E	L	M		
16	16H200JA	2.546	2 ⁵¹ / ₆₄	EF-1*	JA	1/2 - 1/4	1 ²⁵ / ₃₂	—	1 ¹ / ₁₆	1/2	2.6
18	18H200SH	2.865	3 ³ / ₆₄	EF-1*	SH	1/2 - 1 ¹¹ / ₁₆	1 ¹⁷ / ₃₂	—	1 ³ / ₁₆	3/16	1.6
20	20H200SH	3.183	3 ⁷ / ₁₆	EF-1*	SH	1/2 - 1 ¹¹ / ₁₆	1 ¹⁷ / ₃₂	—	1 ³ / ₁₆	3/16	2.2
22	22H200SD	3.501	3 ³ / ₄	EF-1*	SD	1/2 - 2	1 ³ / ₃₂	—	1 ¹³ / ₁₆	5/8	2.5
24	24H200SD	3.820	4 ¹ / ₁₆	EF-1*	SD	1/2 - 2	1 ³ / ₃₂	—	1 ¹³ / ₁₆	5/8	3.0
26	26H200SD	4.138	4 ²⁵ / ₃₂	HF-1	SD	1/2 - 2	3/4	3 ⁵ / ₆₄	1 ¹³ / ₁₆	3 ⁵ / ₆₄	3.9
28	28H200SD	4.456	4 ⁴⁵ / ₆₄	HF-1	SD	1/2 - 2	3/4	3 ⁵ / ₆₄	1 ¹³ / ₁₆	3 ⁵ / ₆₄	4.7
30	30H200SD	4.775	5 ¹ / ₄	HF-1	SD	1/2 - 2	3/4	3 ⁵ / ₆₄	1 ¹³ / ₁₆	3 ⁵ / ₆₄	5.7
32	32H200SK	5.093	5 ²¹ / ₆₄	HF-1	SK	1/2 - 2 ³ / ₄	3/4	3 ⁵ / ₆₄	1 ¹⁵ / ₁₆	3 ⁵ / ₆₄	6.7
36	36H200SK	5.730	5 ⁵ / ₁₆	HF-1	SK	1/2 - 2 ³ / ₄	3/4	3 ⁵ / ₆₄	1 ¹⁵ / ₁₆	3 ⁵ / ₆₄	8.0
40	40H200SK	6.366	6 ³⁷ / ₆₄	HF-1	SK	1/2 - 2 ³ / ₄	3/4	3 ⁵ / ₆₄	1 ¹⁵ / ₁₆	3 ⁵ / ₆₄	10.2
44	44H200SK	7.003	7 ¹ / ₄	HF-1	SK	1/2 - 2 ³ / ₄	3/4	3 ⁵ / ₆₄	1 ¹⁵ / ₁₆	3 ⁵ / ₆₄	12.5
48	48H200SF	7.639	8 ¹ / ₄	HF-2	SF	1/2 - 2 ¹⁵ / ₁₆	3/4	3 ⁵ / ₆₄	2 ¹ / ₁₆	3 ⁵ / ₆₄	14.1
60	60H200SF	9.549	—	H-2	SF	1/2 - 2 ¹⁵ / ₁₆	3/4	3 ⁵ / ₆₄	2 ¹ / ₁₆	3 ⁵ / ₆₄	14.6
72	72H200SF	11.459	—	H-3	SF	1/2 - 2 ¹⁵ / ₁₆	3/4	3 ⁵ / ₆₄	2 ¹ / ₁₆	3 ⁵ / ₆₄	21.0
84	84H200SF	13.369	—	H-3	SF	1/2 - 2 ¹⁵ / ₁₆	3/4	3 ⁵ / ₆₄	2 ³ / ₁₆	3 ⁵ / ₆₄	23.0
96	96H200E	15.279	—	H-3	E	3/8 - 3/4	2 ³ / ₆₄	2 ³ / ₆₄	2 ⁵ / ₁₆	2 ³ / ₆₄	34.0
120	120H200E	19.099	—	H-3	E	3/8 - 3/2	2 ³ / ₆₄	2 ³ / ₆₄	2 ⁵ / ₁₆	2 ³ / ₆₄	42.0

Dimensions in inches. Weight in pounds
Pulley O.D. = P.D. - .054"
*Reverse mount only

H — 1/2" Pitch

H200 For Belts 2" Wide (1/2" Pitch)

Taper Bushed Type

F = 2¹/₃₂

No. Teeth	Part Number	Pitch Diameter	Max. FL. O.D.	Type	Bush	Bore Range	Dimensions			Wt. Less Bush.
							E	L	M	
16	TB16H200	2.546	2 ²⁵ / ₆₄	KF-1	1008	1/2 - 1	3/4	7/8	2 ²³ / ₃₂	1.9
18	TB18H200	2.865	3 ³ / ₆₄	KF-1	1215	1/2 - 1 ¹ / ₄	7/16	1 ¹ / ₂	1 ¹⁹ / ₃₂	1.8
20	TB20H200	3.183	3 ⁷ / ₁₆	KF-1	1215	1/2 - 1 ¹ / ₄	2 ⁷ / ₆₄	1 ¹ / ₂	2 ⁷ / ₆₄	2.6
22	TB22H200	3.501	3 ³ / ₄	KF-1	1615	1/2 - 1 ⁵ / ₈	2 ⁷ / ₆₄	1 ¹ / ₂	2 ⁷ / ₆₄	2.8
24	TB24H200	3.820	4 ¹ / ₁₆	KF-1	2012	1/2 - 2	3 ⁵ / ₆₄	1 ¹ / ₄	3 ⁵ / ₆₄	2.8
26	TB26H200	4.138	4 ²⁵ / ₃₂	KF-1	2012	1/2 - 2	3 ⁵ / ₆₄	1 ¹ / ₄	3 ⁵ / ₆₄	3.6
28	TB28H200	4.456	4 ⁴⁵ / ₆₄	KF-1	2012	1/2 - 2	3 ⁵ / ₆₄	1 ¹ / ₄	3 ⁵ / ₆₄	5.1
30	TB30H200	4.775	5 ¹ / ₄	KF-1	2012	1/2 - 2	1 ³ / ₃₂	1 ¹ / ₄	—	7.0
32	TB32H200	5.093	5 ²¹ / ₆₄	KF-1	2517	1/2 - 2 ¹ / ₂	1 ⁹ / ₃₂	1 ³ / ₄	—	8.5
40	TB40H200	6.366	6 ³⁷ / ₆₄	KF-1	2517	1/2 - 2 ¹ / ₂	1 ⁹ / ₃₂	1 ³ / ₄	—	9.9
48	TB48H200	7.639	8 ¹ / ₄	KF-1	3020	3/8 - 3	1 ¹¹ / ₃₂	2	—	14.3
60	TB60H200	9.549	—	A-2	3020	3/8 - 3	1 ¹ / ₆₄	2	1 ¹ / ₆₄	15.3

Dimensions in inches. Weight in pounds
Pulley O.D. = P.D. - .054"

1/2" Pitch Timing Pulleys | H

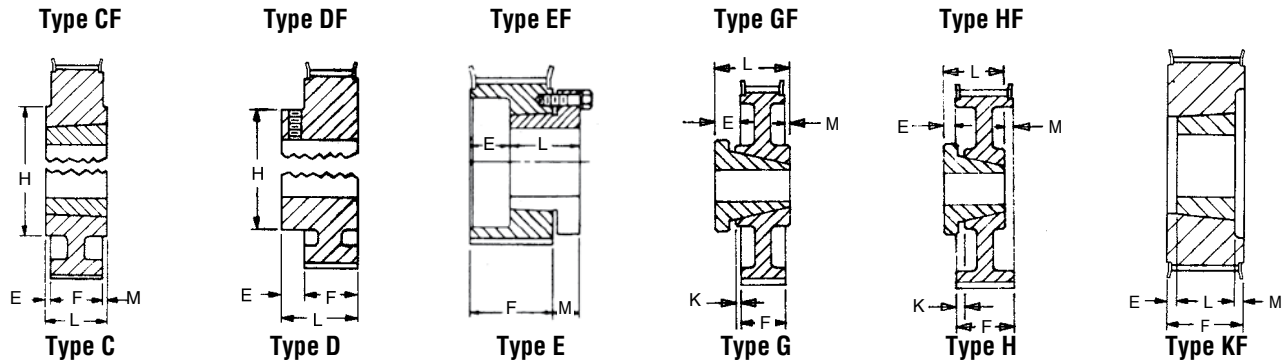

Dash 1 = Solid Style

Dash 2 = Web Style

Dash 3 = Arm/Spoke Style

H - 1/2" Pitch

H300 For Belts 3" Wide (1/2" Pitch)

Minimum Plain Bore

F = 3-3/8"

No. Teeth	Part Number	Pitch Diameter	Max. FL. O.D.	Type	Bore		Dimensions			Wt.
					Stk.	Max.	E	H	L	
16	16H300	2.546	2 ^{5/64}	DF-1	3/4	1 1/4	3/4	2	4 1/8	4.2

Dimensions in inches. Weight in pounds
Pulley O.D. = P.D. - .054"

H - 1/2" Pitch

H300 For Belts 3" Wide (1/2" Pitch)

QD Type

F = 3-3/8"

No. Teeth	Part Number	Pitch Diameter	Max. FL. O.D.	Type	Bush	Bore Range	Dimensions				Wt. Less Bush.
							E	K	L	M	
22	22H300SD	3.501	3 3/4	EF-1*	SD	1/2 - 2	2 1/8	—	1 1/16	3/8	4.1
24	24H300SD	3.820	4 1/16	EF-1*	SD	1/2 - 2	2 1/8	—	1 1/16	3/8	4.1
26	26H300SD	4.138	4 25/64	JF-1	SD	1/2 - 2	7/16	1 1/16	1 1/16	1 1/16	5.0
28	28H300SD	4.456	4 49/64	JF-1	SD	1/2 - 2	7/16	1 1/16	1 1/16	1 1/16	6.0
30	30H300SD	4.775	5 1/64	JF-1	SD	1/2 - 2	7/16	1 1/16	1 1/16	1 1/16	7.2
32	32H300SK	5.093	5 21/64	JF-1	SK	1/2 - 2 1/8	3/8	1 1/16	1 15/16	1 1/16	8.4
36	36H300SK	5.730	5 81/64	JF-1	SK	1/2 - 2 1/8	3/8	1 1/16	1 15/16	1 1/16	10.0
40	40H300SK	6.366	6 39/64	JF-1	SK	1/2 - 2 1/8	3/8	1 1/16	1 15/16	1 1/16	12.2
44	44H300SK	7.003	7 1/4	JF-1	SK	1/2 - 2 1/8	3/8	1 1/16	1 15/16	1 1/16	15.5
48	48H300SF	7.639	8 1/64	JF-2	SF	1/2 - 2 15/16	3/8	1 1/16	2 1/8	1 1/16	16.6
60	60H300SF	9.549	—	J-2	SF	1/2 - 2 15/16	3/8	1 1/16	2 1/8	1 1/16	17.9
72	72H300SF	11.459	—	J-2	SF	1/2 - 2 15/16	3/8	1 1/16	2 1/8	1 1/16	23.0
84	84H300SF	13.369	—	J-2	SF	1/2 - 2 15/16	3/8	1 1/16	2 1/8	1 1/16	30.0
96	96H300E	15.279	—	H-3	E	3/8 - 3 1/2	0	7/8	2 3/8	7/8	38.0
120	120H300E	19.099	—	H-3	E	3/8 - 3 1/2	0	7/8	2 3/8	7/8	51.0

Dimensions in inches. Weight in pounds
Pulley O.D. = P.D. - .054"

*Reverse mount only

H - 1/2" Pitch

H300 For Belts 3" Wide (1/2" Pitch)

Taper Bushed Type

F = 3-3/8"

No. Teeth	Part Number	Pitch Diameter	Max. FL. O.D.	Type	Bush	Bore Range	Dimensions			Wt. Less Bush.
							E	L	M	
18	TB18H300	2.865	3 3/64	KF-1	1215	1/2 - 1 1/4	15/16	1 1/2	15/16	2.6
20	TB20H300	3.183	3 1/16	KF-1	1215	1/2 - 1 1/4	15/16	1 1/2	15/16	3.9
22	TB22H300	3.501	3 3/4	KF-1	1615	1/2 - 1 1/8	15/16	1 1/2	15/16	4.0
24	TB24H300	3.820	4 1/16	KF-1	2012	1/2 - 2	1 1/16	1 1/4	1 1/16	4.3
26	TB26H300	4.138	4 25/64	KF-1	2012	1/2 - 2	1 1/16	1 1/4	1 1/16	5.4
28	TB28H300	4.456	4 49/64	KF-1	2012	1/2 - 2	1 1/16	1 1/4	1 1/16	6.8
30	TB30H300	4.775	5 1/64	KF-1	2012	1/2 - 2	1 1/16	1 1/4	1 1/16	7.5
32	TB32H300	5.093	5 21/64	KF-1	2517	1/2 - 2 1/2	13/16	1 3/4	13/16	7.4
40	TB40H300	6.366	6 39/64	KF-1	2517	1/2 - 2 1/2	13/16	1 3/4	13/16	12.1
48	TB48H300	7.639	8 1/64	KF-1	3020	3/8 - 3	1 1/16	2	1 1/16	16.3
60	TB60H300	9.549	—	A-2	3020	3/8 - 3	9/16	2	9/16	17.3

Dimensions in inches. Weight in pounds
Pulley O.D. = P.D. - .054"

XH | 7/8" Pitch Timing Pulleys

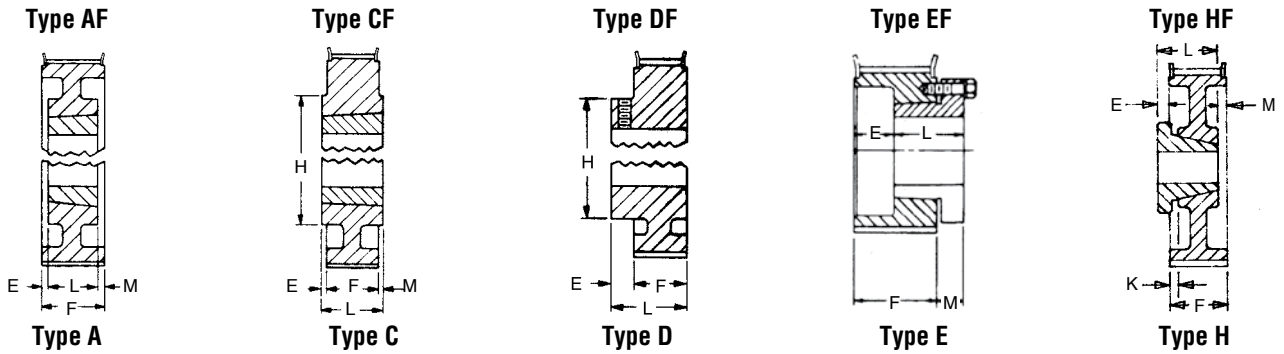

Dash 1 = Solid Style

Dash 2 = Web Style

Dash 3 = Arm/Spoke Style

"F" in type description indicates flanged.

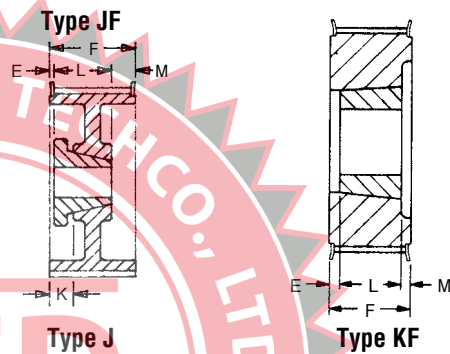

XH — 7/8" Pitch

XH200 For Belts 2" Wide (7/8" Pitch)

Minimum Plain Bore

F = 2 1/16

No. Teeth	Part Number	Pitch Diameter	Max. FL O.D.	Type	Bore		Dimensions			Wt.
					Stk.	Max.	E	H	L	
18	18XH200	5.013	5 7/64	DF-1	1	2 5/8	7/8	3 1/16	3 3/16	12.0
20	20XH200	5.570	6 7/64	DF-1	1	3 1/4	1	4 1/8	3 3/16	16.0

Dimensions in inches. Weight in pounds
Pulley O.D. = P.D. - .11"

XH — 7/8" Pitch

XH200 For Belts 2" Wide (7/8" Pitch)

Taper Bushed Type

F = 2 1/16

No. Teeth	Part Number	Pitch Diameter	Max. FL O.D.	Type	Bush	Bore Range	Dimensions				Wt. Less Bush.
							E	H	L	M	
22	TB22XH200	6.127	6 19/32	KF-1	2517	1/2 - 2 1/2	13/16	—	1 3/4	—	10.6
24	TB24XH200	6.685	7 7/32	KF-1	3020	3/8 - 3	3/16	—	2	—	11.3
26	TB26XH200	7.241	7 29/32	KF-1	3020	3/8 - 3	3/16	—	2	—	13.3
28	TB28XH200	7.799	8 11/64	CF-1	3535	1 1/16 - 3 1/2	15/16	6 1/2	3 1/2	—	13.5
30	TB30XH200	8.356	9 1/32	CF-1	3535	1 1/16 - 3 1/2	15/16	6 1/2	3 1/2	—	18.5
32	TB32XH200	8.913	9 39/64	CF-1	3535	1 1/16 - 3 1/2	15/16	6 1/2	3 1/2	—	21.5
40	TB40XH200	11.141	11 81/64	CF-1	4040	1 1/16 - 4	1 7/16	8 1/2	4	—	37.5
48	TB48XH200	13.369	—	C-2	4040	1 1/16 - 4	1 3/32	8 1/2	4	23 3/32	44.5
60	TB60XH200	16.711	—	C-3	4040	1 1/16 - 4	2 3/32	8 1/2	4	23 3/32	47.0

Dimensions in inches. Weight in pounds
Pulley O.D. = P.D. - .11"

7/8" Pitch Timing Pulleys | XH

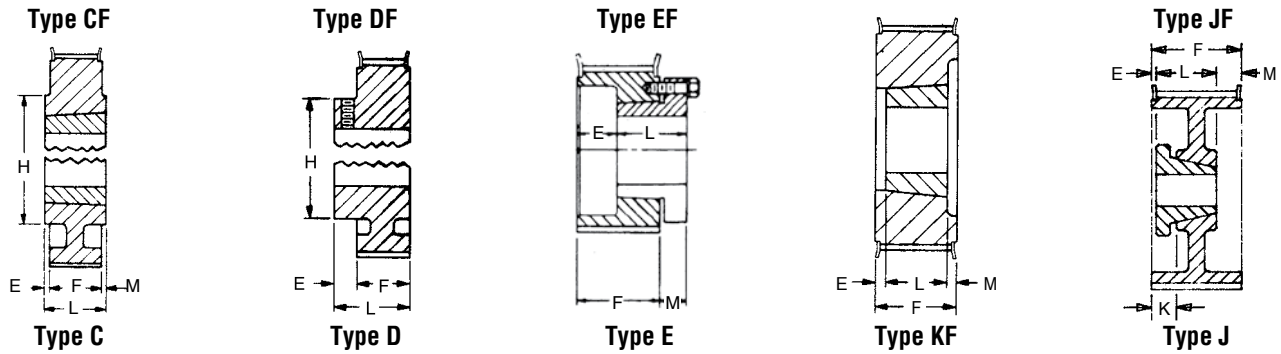

XH — 7/8" Pitch

XH300 For Belts 3" Wide (7/8" Pitch)

Minimum Plain Bore

F = 3 5/8"

No. Teeth	Part Number	Pitch Diameter	Max. FL O.D.	Type	Bore		E	Dimensions			Wt.
					Stk.	Max.		H	L	M	
18	18XH300	5.013	5 37/64	DF-1	1	2 1/8	7/8	3 11/16	4 1/2	1*	15.0
20	20XH300	5.570	6 1/64	DF-1	1	3 3/4	1	4 1/8	4 3/4	3/4*	19.0

*Counterbore "M" depth on flush side.

XH — 7/8" Pitch

XH300 For Belts 3" Wide (7/8" Pitch)

Taper Bushed Type

F = 3 3/8"

No. Teeth	Part Number	Pitch Diameter	Max. FL O.D.	Bore Type	Bush	Bore Range	E	Dimensions			Wt.
								H	L	M	
22	TB22XH300	6.127	6 1/32	KF-1	2517	1/2 - 2 1/2	1 1/16	—	1 3/4	1 9/16	13.6
24	TB24XH300	6.685	7 3/32	KF-1	3020	7/8 - 3	1 1/16	—	2	1 9/16	15.3
26	TB26XH300	7.241	7 7/32	KF-1	3020	1 - 3	1 1/16	—	2	1 9/16	17.3
28	TB28XH300	7.799	8 1/64	KF-1	3535	1 1/8 - 3 1/2	1/8	—	3 1/2	—	17.5
30	TB30XH300	8.356	9 1/32	KF-1	3535	1 1/8 - 3 1/2	1/8	—	3 1/2	—	22.5
32	TB32XH300	8.913	9 3/64	KF-1	3535	1 1/8 - 3 1/2	1/8	—	3 1/2	—	26.5
40	TB40XH300	11.141	11 1 1/4	KF-1	4040	1 1/8 - 4	3/8	7 1/4	4	—	43.5
48	TB48XH300	13.369	—	C-2	4040	1 1/8 - 4	3/16	8 1/2	4	3/16	51.5
60	TB60XH300	16.711	—	C-3	4040	1 1/8 - 4	3/16	8 1/2	4	3/16	55.5

XH — 7/8" Pitch

XH400 For Belts 4" Wide (7/8" Pitch)

QD Type

F = 4 1 1/16"

No. Teeth	Part Number	Pitch Diameter	Max. FL O.D.	Type	Bush	Bore Range	E	Dimensions			Wt.
								K	L	M	
20	20XH400SK	5.570	6 3/32	JF-1	SK	1/2 - 2 1/2	1/2	1 1/16	1 1/16	2 1/4	12.4
22	22XH400SK	6.127	6 21/32	JF-1	SK	1/2 - 2 1/2	1/2	1 1/16	1 1/16	2 1/4	16.7
24	24XH400SF	6.685	7 1/32	JF-1	SF	1/2 - 2 1/2	1/2	1 1/16	2 1/16	2 3/16	19.2
26	26XH400SF	7.242	7 29/32	JF-1	SF	1/2 - 2 1/2	1/2	1 1/16	2 1/4	2 3/16	23.0
28	28XH400E	7.799	8 1 1/32	JF-1	E	7/8 - 3 1/2	2 1/32	1 1 1/2	2 3/8	1 13/32	24.0
30	30XH400E	8.356	8 29/32	JF-1	E	7/8 - 3 1/2	2 1/32	1 1 1/2	2 3/8	1 13/32	30.7
32	32XH400E	8.913	9 1/16	JF-1	E	7/8 - 3 1/2	2 1/32	1 1 1/2	2 3/8	1 13/32	34.0
40	40XH400F	11.141	11 1 1/16	HF-2	F	1 - 3 1/16	3/32	1 1 1/2	3 3/8	1 1/2	49.0
48	48XH400J	13.369	—	H-3	J	1 1/8 - 4 1/2	3/16	1	4 1/2	7/8	67.3
60	60XH400J	16.711	—	H-3	J	1 1/8 - 4 1/2	3/16	3/4	4 1/2	5/8	85.0
72	72XH400J	20.054	—	H-3	J	1 1/8 - 4 1/2	7/16	3/4	4 1/2	5/8	108.0
84	84XH400J	23.396	—	H-3	J	1 1/8 - 4 1/2	7/16	3/4	4 1/2	5/8	119.0
96	96XH400J	26.738	—	H-3	J	1 1/8 - 4 1/2	7/16	3/4	4 1/2	5/8	187.5
120	120XH400J	33.423	—	H-3	J	1 1/8 - 4 1/2	7/16	3/4	4 1/2	5/8	187.5

Dimensions in inches. Weight in pounds
Pulley O.D. = P.D. - .11"

5mm | High Torque Sprockets

For use with:

Panther®

Synchro-Cog® HT

Dual Synchronous
Belt

Air Cool Heat
Exchange Belt



High Torque Sprockets | 5mm

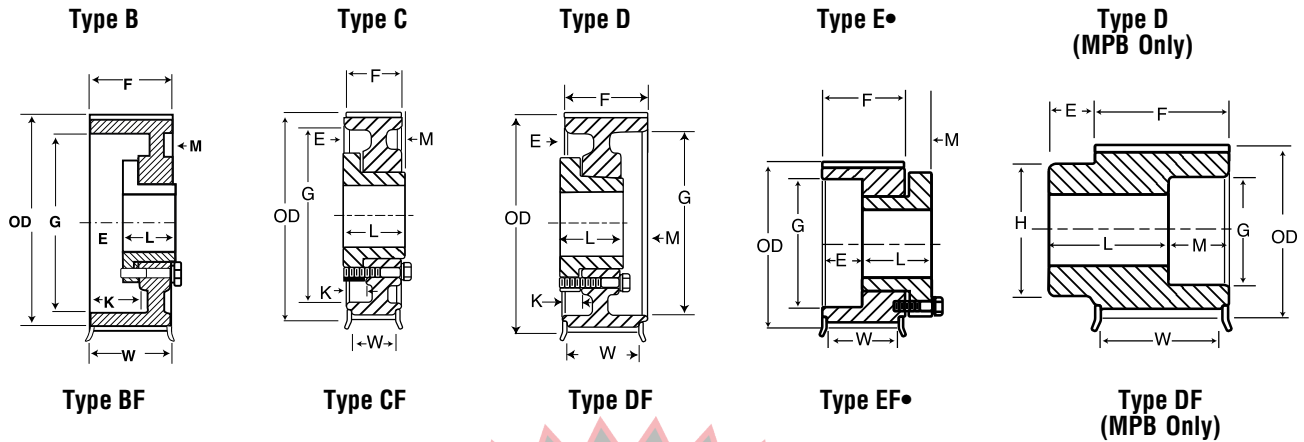

MPB 15mm (.591 in.) Wide Belts (5M-15)																
No. of Teeth	Catalog Number	Bore	Pitch	Diameter (in.)		Type +	Max. Bore	Dimensions (in.)								Weight* Approx. (lbs)
				O.D.	Flange			E	L	M	K	H	F	G	W	
32	P325M15-MPB	1/2	2.005	1.960	2.16	DF-1	0.88	0.50	1.73	—	—	1.55	0.84	—	0.65	1.12
34	P345M15-MPB	1/2	2.130	2.085	2.29	DF-1	1.00	0.50	1.73	—	—	1.68	0.84	—	0.65	1.25
36	P365M15-MPB	1/2	2.256	2.211	2.41	DF-1	1.12	0.50	1.73	—	—	1.80	0.84	—	0.65	1.39
QD 15mm (.591in.) Wide Belts (5M-15)																
38	P385M15-JA	JA	2.381	2.336	2.54	• EF-1	1.25	0.67	1.00	0.44	—	—	0.84	1.34	0.65	0.80
40	P405M15-JA	JA	2.506	2.461	2.66	• EF-1	1.25	0.67	1.00	0.44	—	—	0.84	1.34	0.65	1.06
44	P445M15-JA	JA	2.757	2.712	2.91	• EF-1	1.25	0.67	1.00	0.44	—	—	0.84	1.34	0.65	1.40
48	P485M15-JA	JA	3.008	2.963	3.16	BF-1	1.25	0.23	1.00	0.00	0.67	—	0.84	2.36	0.65	1.20
52	P525M15-JA	JA	3.258	3.213	3.41	BF-1	1.25	0.23	1.00	0.00	0.67	—	0.84	2.62	0.65	1.43
56	P565M15-SH	SH	3.509	3.464	3.66	DF-1	1.68	0.08	1.25	0.06	0.42	—	0.84	2.86	0.65	1.64
60	P605M15-SH	SH	3.760	3.715	3.92	DF-1	1.68	0.08	1.25	0.06	0.42	—	0.84	3.12	0.65	1.83
64	P645M15-SH	SH	4.010	3.965	4.16	DF-1	1.68	0.08	1.25	0.06	0.42	—	0.84	3.37	0.65	2.16
68	P685M15-SDS	SDS	4.261	4.216	4.41	CF-1	2.00	0.08	1.31	0.00	0.48	—	0.84	3.50	0.65	2.48
72	P725M15-SDS	SDS	4.511	4.466	4.66	CF-1	2.00	0.08	1.31	0.00	0.48	—	0.84	3.75	0.65	2.84
80	P805M15-SDS	SDS	5.013	4.968	—	C-1	2.00	0.08	1.31	0.00	0.48	—	0.84	4.25	0.65	3.61
90	P905M15-SDS	SDS	5.639	5.594	—	C-1	2.00	0.08	1.31	0.00	0.48	—	0.84	4.88	0.65	4.69
112	P1125M15-SDS	SDS	7.018	6.973	—	C-2	2.00	0.08	1.31	0.00	0.48	—	0.84	6.05	0.65	6.02
MPB 25mm (.984in.) Wide Belts (5M-25)																
32	P325M25-MPB	1/2	2.005	1.960	2.16	DF-1	0.88	0.50	1.34	—	—	1.55	1.23	—	1.04	0.84
34	P345M25-MPB	1/2	2.130	2.085	2.29	DF-1	1.00	0.50	1.34	—	—	1.68	1.23	—	1.04	0.93-
36	P365M25-MPB	1/2	2.256	2.211	2.41	DF-1	1.12	0.50	1.34	—	—	1.80	1.23	—	1.04	1.03
QD 25mm (.984in.) Wide Belts (5M-25)																
38	P385M25-JA	JA	2.381	2.336	2.54	• EF-1	1.25	0.28	1.00	0.44	—	—	1.23	1.34	1.04	0.61
40	P405M25-JA	JA	2.506	2.461	2.66	• EF-1	1.25	0.28	1.00	0.44	—	—	1.23	1.34	1.04	0.72
44	P445M25-JA	JA	2.757	2.712	2.91	• EF-1	1.25	0.28	1.00	0.44	—	—	1.23	1.34	1.04	0.95
48	P485M25-JA	JA	3.008	2.963	3.16	CF-1	1.25	0.16	1.00	0.00	0.28	—	1.23	2.36	1.04	0.97
52	P525M25-JA	JA	3.258	3.213	3.41	CF-1	1.25	0.16	1.00	0.00	0.28	—	1.23	2.62	1.04	1.17
56	P565M25-SH	SH	3.509	3.464	3.66	DF-1	1.68	0.50	1.25	0.09	0.00	—	1.23	—	1.04	1.37
60	P605M25-SH	SH	3.760	3.715	3.92	DF-1	1.68	0.50	1.25	0.09	0.00	—	1.23	—	1.04	1.68
64	P645M25-SH	SH	4.010	3.965	4.16	DF-1	1.68	0.50	1.25	0.09	0.00	—	1.23	—	1.04	1.80
68	P685M25-SDS	SDS	4.261	4.216	4.41	CF-1	2.00	0.47	1.31	0.00	0.09	—	1.23	3.50	1.04	2.10
72	P725M25-SDS	SDS	4.511	4.466	4.66	CF-1	2.00	0.47	1.31	0.00	0.09	—	1.23	3.75	1.04	2.43
80	P805M25-SDS	SDS	5.013	4.968	—	C-1	2.00	0.47	1.31	0.00	0.09	—	1.23	4.25	1.04	3.15
90	P905M25-SDS	SDS	5.639	5.594	—	C-1	2.00	0.47	1.31	0.00	0.09	—	1.23	4.88	1.04	4.17
112	P1125M25-SDS	SDS	7.018	6.973	—	C-1	2.00	0.47	1.31	0.00	0.09	—	1.23	6.05	1.04	5.16

* Weight Shown is for Sprocket Less Bushing.
• Reverse Mount Only

+ The numbers (1=Solid, 2=Web, 3=Arms) within the "Type" indicates construction, and the letter F indicates the sprocket has flanges.

8mm | High Torque Sprockets

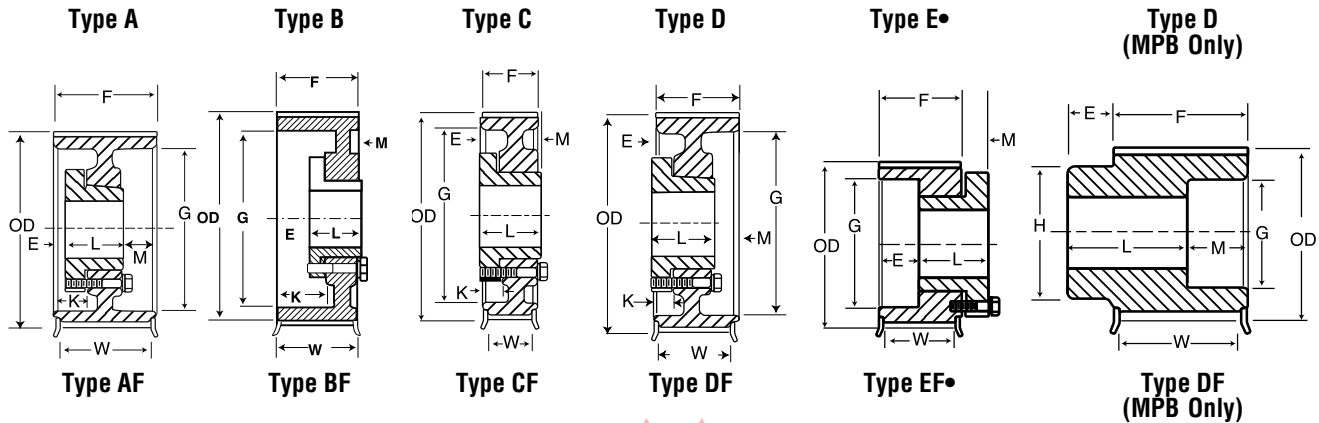

MPB 20mm (.787 in.) Wide Belts (8M-20)																
No. of Teeth	Catalog Number	Bore	Pitch	Diameter (in.)		Type +	Max. Bore	Dimensions (in.)							Weight* Approx. (lbs)	
				O.D.	Flange			E	L	M	K	H	F	G		W
20	P208M20-MPB	½	2.005	1.951	2.375	DF-1	¾	¾	1 ¼	0	—	1 ½	1 ½	—	¾	.90
21	P218M20-MPB	½	2.105	2.051	2.468	DF-1	1	¾	1 ¼	0	—	1 ½	1 ½	—	¾	1.00
22	P228M20-MPB	½	2.206	2.152	2.562	DF-1	1 ⅛	¾	1 ¼	0	—	1 ½	1 ½	—	¾	1.60
QD 20mm (.787 in.) Wide Belts (8M-20)																
24	P248M20-JA	JA	2.406	2.352	2.750	• EF-1	1 ¼	¾	1 ¼	¾	—	—	1 ½	1.34	¾	1.50
26	P268M20-JA	JA	2.607	2.553	2.937	• EF-1	1 ¼	¾	1 ¼	¾	—	—	1 ½	1.34	¾	1.80
28	P288M20-H	H	2.807	2.753	3.156	• EF-1	1 ¼	¾	1 ¼	¾	—	—	1 ½	1.57	¾	1.40
30	P308M20-H	H	3.008	2.954	3.344	• EF-1	1 ¼	¾	1 ¼	¾	—	—	1 ½	1.57	¾	1.90
32	P328M20-H	H	3.208	3.154	3.562	CF-1	1 ½	¾	1 ¼	0	¼	—	1 ½	2.56	¾	2.00
34	P348M20-SH	SH	3.409	3.355	3.750	DF-1	1 ½	¾	1 ¼	¾	5 ⅛	—	1 ½	2.75	¾	2.20
36	P368M20-SH	SH	3.609	3.555	3.937	DF-1	1 ½	¾	1 ¼	¾	5 ⅛	—	1 ½	2.82	¾	2.50
38	P388M20-SH	SH	3.810	3.756	4.156	DF-1	1 ½	¾	1 ¼	¾	5 ⅛	—	1 ½	3.00	¾	2.80
40	P408M20-SH	SH	4.010	3.956	4.344	DF-1	1 ½	¾	1 ¼	¾	5 ⅛	—	1 ½	3.00	¾	3.00
44	P448M20-SDS	SDS	4.411	4.357	4.750	CF-1	2	¾	1 ¼	0	¾	—	1 ½	3.50	¾	3.20
48	P488M20-SDS	SDS	4.812	4.758	5.157	CF-1	2	¾	1 ¼	0	¾	—	1 ½	3.8	¾	3.40
56	P568M20-SDS	SDS	5.614	5.560	5.937	CF-1	2	¾	1 ¼	0	¾	—	1 ½	4.6	¾	4.50
64	P648M20-SDS	SDS	6.416	6.362	6.750	CF-1	2	¾	1 ¼	0	¾	—	1 ½	5.4	¾	5.50
72	P728M20-SDS	SDS	7.218	7.164	7.562	CF-1	2	¾	1 ¼	0	¾	—	1 ½	6.2	¾	6.00
80	P808M20-SDS	SDS	8.020	7.966	8.375	CF-2	2	¾	1 ¼	0	¾	—	1 ½	6.9	¾	6.50
90	P908M20-SDS	SDS	9.023	8.969	—	C-2	2	¾	1 ¼	0	¾	—	1 ½	7.62	—	7.00
112	P1128M20-SK	SK	11.229	11.175	—	C-3	2 ½	¾	1 ½	¾	7 ⅛	—	1 ½	9.87	—	10.50
144	P1448M20-SF	SF	14.447	14.388	—	C-3	2 ½	¾	1 ½	¾	7 ⅛	—	1 ½	12.88	—	14.50
Taper Bushed 20mm (.787 in.) Wide Belts (8M-20)																
24	P248M20-1108	1108	2.406	2.352	2.75	KF-1	1	¾	¾	¾	—	—	1 ½	1.783	¾	.7
26	P268M20-1108	1108	2.607	2.553	2.94	KF-1	1	¾	¾	¾	—	—	1 ½	1.971	¾	.9
28	P288M20-1108	1108	2.807	2.753	3.16	KF-1	1	¾	¾	¾	—	—	1 ½	2.000	¾	1.2
30	P308M20-1210	1210	3.008	2.954	3.34	KF-1	1 ¼	¾	1	—	—	—	1 ½	—	¾	1.2
32	P328M20-1210	1210	3.208	3.154	3.56	KF-1	1 ¼	¾	1	—	—	—	1 ½	—	¾	1.4
34	P348M20-1610	1610	3.409	3.355	3.75	KF-1	1 ½	¾	1	—	—	—	1 ½	—	¾	1.4
36	P368M20-1610	1610	3.609	3.555	3.94	KF-1	1 ½	¾	1	—	—	—	1 ½	—	¾	1.7
38	P388M20-1610	1610	3.810	3.756	4.16	KF-1	1 ½	¾	1	—	—	—	1 ½	—	¾	2.0
40	P408M20-1610	1610	4.010	3.956	4.34	KF-1	1 ½	¾	1	—	—	—	1 ½	—	¾	2.4
44	P448M20-2012	2012	4.411	4.357	4.75	CF-1	2 ½	—	1 ¼	¾	—	3 ⅞	1 ½	—	¾	2.6
48	P488M20-2012	2012	4.812	4.758	5.16	CF-1	2 ½	—	1 ¼	¾	—	3 ⅞	1 ½	—	¾	3.4
56	P568M20-2012	2012	5.614	5.560	5.94	CF-1	2 ½	—	1 ¼	¾	—	3 ⅞	1 ½	—	¾	5.3
64	P648M20-2012	2012	6.416	6.362	6.75	CF-1	2 ½	—	1 ¼	¾	—	4 ⅞	1 ½	—	¾	7.5
72	P728M20-2012	2012	7.218	7.164	7.56	CF-1	2 ½	—	1 ¼	¾	—	4 ⅞	1 ½	—	¾	9.9
80	P808M20-2517	2517	8.020	7.966	8.38	CF-2	2 ½	—	1 ¼	¾	—	4 ⅞	1 ½	6.900	¾	11.9
90	P908M20-2517	2517	9.023	8.969	—	C-2	2 ½	—	1 ¼	¾	—	—	1 ½	7.630	—	12.9

* Weight Shown is for Sprocket Less Bushing.
• Reverse Mount Only

+ The numbers (1=Solid, 2=Web, 3=Arms) within the "Type" indicates construction, and the letter F indicates the sprocket has flanges.

High Torque Sprockets | 8mm

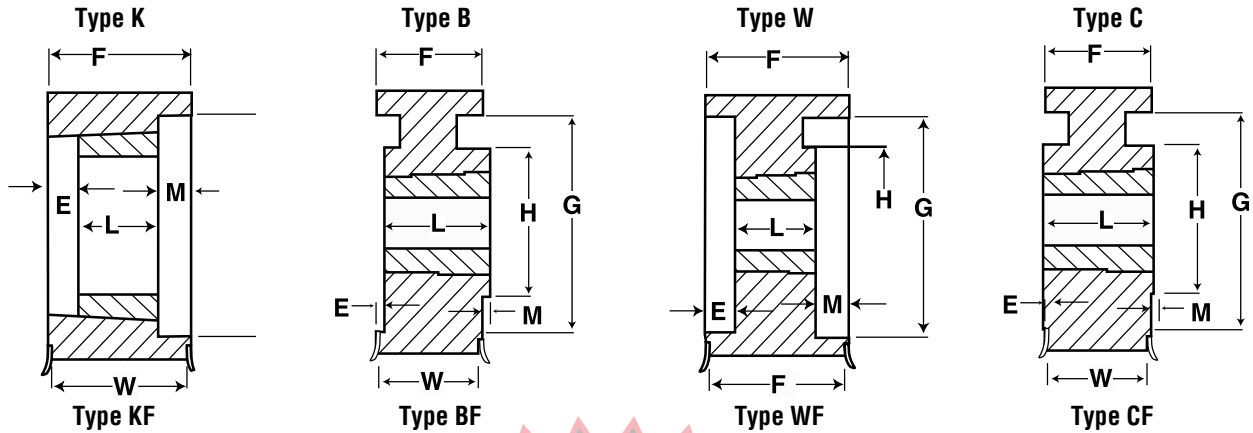

MPB 30mm (1.18in.) Wide Belts (8M-30)																
No. of Teeth	Catalog Number	Bore	Pitch	Diameter (in.)			Max. Bore	Dimensions (in.)							Weight* Approx. (lbs)	
				O.D.	Flange	Type +		E	L	M	K	H	F	G		W
20	P208M30-MPB	½	2.005	1.951	2.375	DF-1	¾	⅝	2⅜	—	—	1⅜	1½	—	1½	1.10
21	P218M30-MPB	½	2.105	2.051	2.468	DF-1	1	⅝	2½	—	—	1½	1½	—	1½	1.30
22	P228M30-MPB	½	2.206	2.152	2.562	DF-1	1⅜	⅝	2⅜	—	—	1½	1½	—	1¼	1.40
24	P248M30-MPB	½	2.406	2.352	2.750	DF-1	1½	⅝	2½	—	—	1⅜	1½	—	1¼	1.80
26	P268M30-MPB	½	2.607	2.553	2.937	DF-1	1¾	¾	2¼	—	—	1½	1½	—	1¼	2.20
QD 30mm (1.18in.) Wide Belts (8M-30)																
28	P288M30-H	H	2.807	2.753	3.156	•EF-1	1¼	⅝	1¼	¾	—	—	1½	1.57	1¼	1.70
30	P308M30-H	H	3.008	2.954	3.344	•EF-1	1⅜	⅝	1¼	¾	—	—	1½	1.57	1¼	1.90
32	P328M30-H	H	3.208	3.154	3.562	BF-1	1⅝	¾	1¼	—	⅝	—	1½	2.56	1¼	2.10
34	P348M30-SH	SH	3.409	3.355	3.750	AF-1	1¾	⅝	1¼	⅜	1⅜	—	1½	2.75	1¼	2.40
36	P368M30-SH	SH	3.609	3.555	3.937	AF-1	1⅞	⅝	1¼	⅜	1⅜	—	1½	2.82	1¼	2.80
38	P388M30-SH	SH	3.810	3.756	4.156	AF-1	1⅞	⅝	1¼	⅜	1⅜	—	1½	3.00	1¼	3.20
40	P408M30-SH	SH	4.010	3.956	4.344	AF-1	1⅞	⅝	1¼	⅜	1⅜	—	1½	3.00	1¼	3.60
44	P448M30-SDS	SDS	4.411	4.357	4.750	BF-1	1⅞	⅝	1⅜	—	¾	—	1½	3.50	1¼	3.80
48	P488M30-SDS	SDS	4.812	4.758	5.157	BF-1	2	⅝	1⅜	—	¾	—	1½	3.80	1¼	4.20
56	P568M30-SDS	SDS	5.614	5.560	5.937	BF-1	2	⅝	1⅜	—	¾	—	1½	4.60	1¼	4.80
64	P648M30-SK	SK	6.416	6.362	6.750	CF-1	2	⅝	1⅜	—	¾	—	1½	5.40	1¼	6.10
72	P728M30-SK	SK	7.218	7.164	7.562	CF-1	2½	⅝	1⅜	—	¾	—	1½	6.20	1¼	6.80
80	P808M30-SK	SK	8.020	7.966	8.375	CF-2	2½	⅝	1⅜	—	¾	—	1½	6.90	1¼	7.50
90	P908M30-SK	SK	9.023	8.969	—	C-2	2½	⅝	1⅜	—	¾	—	1½	7.62	—	11.00
112	P1128M30-SK	SK	11.229	11.175	—	C-3	2½	⅝	1⅜	—	¾	—	1½	9.87	—	13.00
144	P1448M30-SF	SF	14.447	14.383	—	C-3	2⅞	⅝	2⅜	—	¾	—	1½	12.88	—	25.50
192	P1928M30-E	E	19.249	19.195	—	C-3	—	1⅞	2½	⅜	¾	—	1½	17.63	—	30.00
Taper Bushed 30mm (1.18in.) Wide Belts (8M-30)																
24	P248M30-1108	1108	2.406	2.352	2.75	KF-1	1	⅝	7⁄8	½	—	—	1½	1.783	1¼	.9
26	P268M30-1108	1108	2.607	2.553	2.94	KF-1	1	⅝	7⁄8	½	—	—	1½	1.971	1¼	1.2
28	P288M30-1108	1108	2.807	2.753	3.16	KF-1	1	⅝	7⁄8	½	—	—	1½	2.000	1¼	1.6
30	P308M30-1210	1210	3.008	2.954	3.34	KF-1	1¼	⅝	1	¾	—	—	1½	2.345	1¼	1.5
32	P328M30-1210	1210	3.208	3.154	3.56	KF-1	1¼	⅝	1	¾	—	—	1½	2.560	1¼	1.9
34	P348M30-1610	1610	3.409	3.355	3.75	KF-1	1⅞	⅝	1	¾	—	—	1½	2.750	1¼	2.3
36	P368M30-1610	1610	3.609	3.555	3.94	KF-1	1⅞	⅝	1	¾	—	—	1½	2.820	1¼	2.2
38	P388M30-1610	1610	3.810	3.756	4.16	KF-1	1⅞	⅝	1	¾	—	—	1½	3.000	1¼	2.7
40	P408M30-2012	2012	4.010	3.956	4.34	KF-1	2½	—	1¼	¾	—	—	1½	3.250	1¼	2.4
44	P448M30-2012	2012	4.411	4.357	4.75	KF-1	2½	—	1¼	¾	—	—	1½	3.500	1¼	3.4
48	P488M30-2012	2012	4.812	4.758	5.16	KF-1	2½	—	1¼	¾	—	—	1½	3.800	1¼	4.5
56	P568M30-2012	2012	5.614	5.560	5.94	KF-1	2½	—	1¼	¾	—	—	1½	4.600	1¼	7.0
64	P648M30-2517	2517	6.416	6.362	6.75	CF-1	2⅞	—	1¾	—	¾	4%	1½	—	1¼	8.9
72	P728M30-2517	2517	7.218	7.164	7.56	CF-1	2⅞	—	1¾	—	¾	4%	1½	—	1¼	12.1
80	P808M30-2517	2517	8.020	7.966	8.38	CF-2	2⅞	—	1¾	—	¾	4%	1½	—	1¼	15.8
90	P908M30-2517	2517	9.023	8.969	—	C-2	2⅞	⅝	1¾	—	¾	4%	1½	7.630	—	13.8
112	P1128M30-2517	2517	11.229	11.175	—	C-3	2⅞	⅝	1¾	—	¾	4%	1½	9.880	—	23.5
144	P1448M30-2517	2517	14.437	14.383	...	C-3	2⅞	⅝	1¾	—	¾	4%	1½	12.880	—	21.3

* Weight Shown is for Sprocket Less Bushing.
• Reverse Mount Only

+ The numbers (1=Solid, 2=Web, 3=Arms) within the "Type" indicates construction, and the letter F indicates the sprocket has flanges.

8mm | High Torque Sprockets

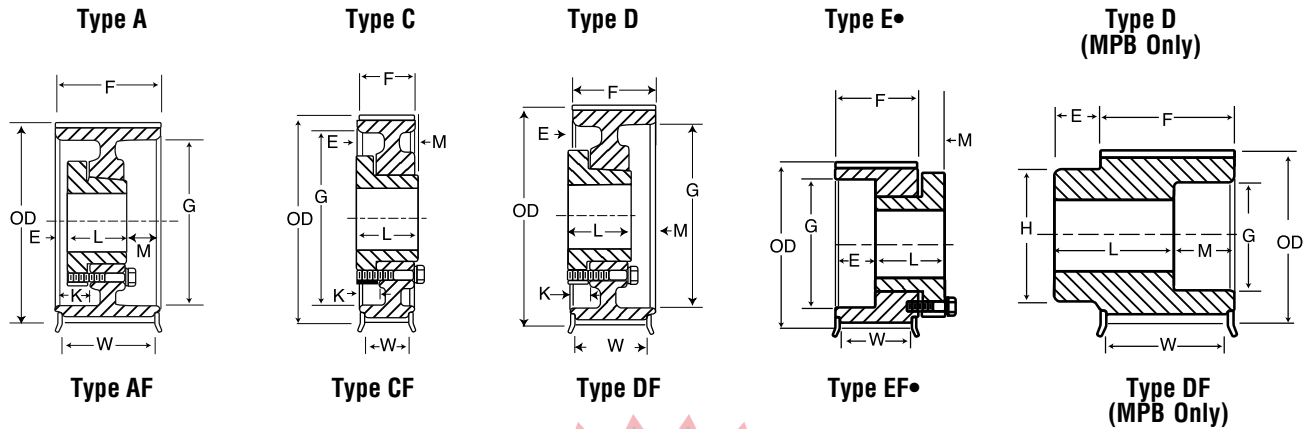

MPB 50mm (1.97 in.) Wide Belts (8M-50)																
No. of Teeth	Catalog Number	Bore	Pitch	Diameter (in.)		Type +	Max. Bore	Dimensions (in.)							Weight* Approx. (lbs)	
				O.D.	Flange			E	L	M	K	H	F	G		W
28	P288M50-MPB	1/2	2.807	2.753	3.156	DF-1	1 1/4	3/4	3 3/8	—	—	2 3/32	2 3/8	—	2 1/2	4.2
30	P308M50-MPB	1/2	3.008	2.954	3.344	DF-1	1 1/4	3/4	3 3/8	—	—	2 1/32	2 3/8	—	2 1/2	4.9
32	P328M50-MPB	1/2	3.208	3.154	3.562	DF-1	1 1/4	3/4	3 3/8	—	—	2 1/32	2 3/8	—	2 1/2	5.4
QD 50mm (1.97 in.) Wide Belts (8M-50)																
32	P328M50-H	H	3.208	3.154	3.562	AF-1	1 1/4	1/2	1 1/4	3/4	—	2 3/8	2.56	2 1/2	2.9	
34	P348M50-SH	SH	3.409	3.355	3.750	AF-1	1 1/4	1/2	1 1/4	1 1/8	—	2 3/8	2.75	2 1/2	3.2	
36	P368M50-SH	SH	3.609	3.555	3.937	AF-1	1 1/4	1/2	1 1/4	1 1/8	1/2	2 3/8	2.82	2 1/2	3.8	
38	P388M50-SH	SH	3.810	3.756	4.156	AF-1	1 1/4	1/2	1 1/4	1 1/8	1/2	2 3/8	3.00	2 1/2	4.2	
40	P408M50-SH	SH	4.010	3.956	4.344	AF-1	1 1/4	1/2	1 1/4	1 1/8	1/2	2 3/8	3.00	2 1/2	4.6	
44	P448M50-SD	SD	4.411	4.357	4.750	AF-1	2	1 1/4	1 1/4	1 1/8	1/2	2 3/8	3.50	2 1/2	5.2	
48	P488M50-SD	SD	4.812	4.758	5.157	AF-1	2	1 1/4	1 1/4	1 1/8	1/2	2 3/8	3.80	2 1/2	6.0	
56	P568M50-SK	SK	5.614	5.560	5.937	DF-1	2 3/8	1 1/4	1 1/4	1 1/8	1/2	2 3/8	4.60	2 1/2	7.6	
64	P648M50-SK	SK	6.416	6.362	6.750	DF-1	2 3/8	1 1/4	1 1/4	1 1/8	1/2	2 3/8	5.40	2 1/2	10.3	
72	P728M50-SK	SK	7.218	7.164	7.562	DF-1	2 3/8	1 1/4	1 1/4	1 1/8	1/2	2 3/8	6.20	2 1/2	13.3	
80	P808M50-SF	SF	8.020	7.966	8.326	DF-1	2 3/8	1 1/4	1 1/4	1 1/8	1/2	2 3/8	6.90	2 1/2	12.7	
90	P908M50-SF	SF	9.023	8.969	—	D-2	2 3/8	1 1/4	2	1 1/8	1/2	2 3/8	7.62	2 1/2	16.0	
112	P1128M50-SF	SF	11.229	11.175	—	D-3	2 3/8	1 1/4	2	1 1/8	1/2	2 3/8	9.88	2 1/2	21.0	
144	P1448M50-E	E	14.437	14.383	—	D-3	3 1/2	1 1/2	2 3/8	2	3/8	2 3/8	12.88	2 1/2	35.0	
192	P1928M50-E	E	19.249	19.195	—	D-3	3 1/2	1 1/2	2 3/8	2	3/8	2 3/8	17.63	2 1/2	45.0	
Taper Bushed 50mm (1.97 in.) Wide Belts (8M-50)																
28	P288M50-1108	1108	2.807	2.753	3.16	KF-1	1	3/8	1 1/2	—	—	2 3/8	2.000	2 1/2	2.1	
30	P308M50-1210	1210	3.008	2.954	3.34	KF-1	1 1/4	—	1	1 1/8	—	2 3/8	2.345	2 1/2	2.2	
32	P328M50-1210	1210	3.208	3.154	3.56	KF-1	1 1/4	—	1	1 1/8	—	2 3/8	2.560	2 1/2	2.1	
34	P348M50-1610	1610	3.409	3.355	3.75	KF-1	1 1/4	—	1	1 1/8	—	2 3/8	2.750	2 1/2	2.1	
36	P368M50-1610	1610	3.609	3.555	3.94	KF-1	1 1/4	—	1	1 1/8	—	2 3/8	2.820	2 1/2	2.7	
38	P388M50-1610	1610	3.810	3.756	4.16	KF-1	1 1/4	—	1	1 1/8	—	2 3/8	3.000	2 1/2	3.1	
40	P408M50-2012	2012	4.010	3.956	4.34	KF-1	2 1/4	—	1 1/4	1 1/8	—	2 3/8	3.250	2 1/2	3.4	
44	P448M50-2012	2012	4.411	4.357	4.75	KF-1	2 1/4	—	1 1/4	1 1/8	—	2 3/8	3.500	2 1/2	4.3	
48	P488M50-2012	2012	4.812	4.758	5.16	KF-1	2 1/4	—	1 1/4	1 1/8	—	2 3/8	3.800	2 1/2	5.5	
56	P568M50-2517	2517	5.614	5.560	5.94	KF-1	2 1/4	—	1 1/4	1 1/8	—	2 3/8	4.600	2 1/2	8.1	
64	P648M50-2517	2517	6.416	6.362	6.75	KF-1	2 1/4	—	1 1/4	1 1/8	—	2 3/8	5.400	2 1/2	11.7	
72	P728M50-2517	2517	7.218	7.164	7.56	KF-1	2 1/4	—	1 1/4	1 1/8	—	2 3/8	6.200	2 1/2	15.7	
80	P808M50-2517	2517	8.020	7.966	8.38	KF-1	2 1/4	—	1 1/4	1 1/8	—	2 3/8	6.900	2 1/2	20.3	
90	P908M50-3020	3020	9.023	8.969	—	W-1	3 1/4	—	2	3/4	—	2 3/8	7.630	2 1/2	31.7	
112	P1128M50-3020	3020	11.229	11.175	—	W-3	3 1/4	—	2	3/4	—	6 1/4	9.880	2 1/2	34.7	
144	P1448M50-3020	3020	14.437	14.383	—	W-3	3 1/4	—	2	3/4	—	7 1/2	12.880	2 1/2	36.0	
192	P1928M50-3020	3020	19.249	19.195	—	W-3	3 1/4	—	2	3/4	—	7 1/2	17.630	2 1/2	67.2	

* Weight Shown is for Sprocket Less Bushing.
• Reverse Mount Only

+ The numbers (1=Solid, 2=Web, 3=Arms) within the "Type" indicates construction, and the letter F indicates the sprocket has flanges.

High Torque Sprockets | 8mm

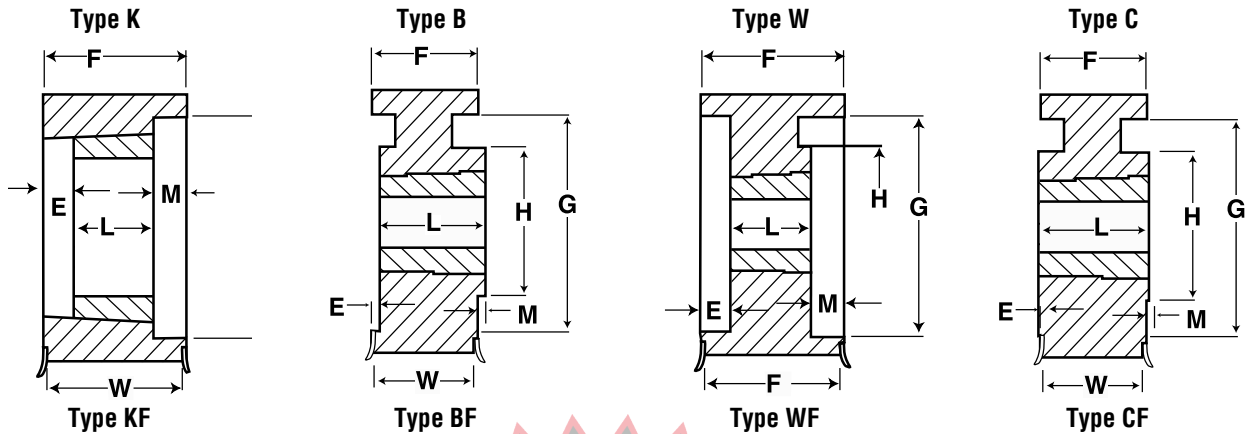

MPB 85mm (3.35 in.) Wide Belts (8M-85)																	
No. of Teeth	Catalog Number	Bore	Pitch	Diameter (in.)		Type +	Max. Bore	Dimensions (in.)									Weight Approx. (lbs)
				O.D.	Flange			E	L	M	K	H	F	G	W		
34	P348M85-MPB	3/4	3.409	3.355	3.750	DF-1	1 1/16	3/4	4 1/2	0	—	2 5/16	3 3/4	—	3 1/2	10.00	
36	P368M85-MPB	3/4	3.609	3.555	3.937	DF-1	1 1/4	3/4	4 1/2	0	—	3	3 3/4	—	3 1/2	11.30	
38	P388M85-MPB	3/4	3.810	3.756	4.156	DF-1	1 5/16	3/4	4 1/2	0	—	3 3/16	3 3/4	—	3 1/2	12.60	
40	P408M85-MPB	3/4	4.010	3.956	4.344	DF-1	2 1/8	3/4	4 1/2	0	—	3 9/32	3 3/4	—	3 1/2	14.90	
44	P448M85-MPB	3/4	4.411	4.357	4.750	DF-1	2 1/4	3/4	4 1/2	0	—	3 5/16	3 3/4	—	3 1/2	17.20	
48	P488M85-MPB	3/4	4.812	4.758	5.157	DF-1	2 1/2	3/4	4 1/2	0	—	4 1/16	3 3/4	—	3 1/2	20.60	
56	P568M85-MPB	3/4	5.614	5.560	5.937	DF-1	3	3/4	4 1/2	0	—	5	3 3/4	—	3 1/2	28.00	
QD 85mm (3.35 in.) Wide Belts (8M-85)																	
34	P348M85-SH	SH	3.409	3.355	3.819	AF-1	1 1/16	1	1 1/4	1 1/2	1 1/2	—	3 3/4	2.75	3 1/2	4.6	
36	P368M85-SH	SH	3.609	3.555	3.937	AF-1	1 1/16	1	1 1/4	1 1/2	1 1/2	—	3 3/4	2.82	3 1/2	5.2	
38	P388M85-SH	SH	3.810	3.756	4.134	AF-1	1 1/16	1	1 1/4	1 1/2	1 1/2	—	3 3/4	3.00	3 1/2	5.8	
40	P408M85-SD	SD	4.010	3.956	4.344	AF-1	2	1 1/16	1 1/2	1 1/4	1 1/4	—	3 3/4	3.25	3 1/2	5.6	
44	P448M85-SD	SD	4.411	4.357	4.750	AF-1	2	1 1/16	1 1/2	1 1/4	1 1/4	—	3 3/4	3.50	3 1/2	6.2	
48	P488M85-SD	SD	4.812	4.758	5.157	AF-1	2	1 1/16	1 1/2	1 1/4	1 1/4	—	3 3/4	3.80	3 1/2	7.8	
56	P568M85-SK	SK	5.614	5.560	5.937	AF-1	2 5/8	5/8	1 1/2	1 1/4	1 1/4	—	3 3/4	4.60	3 1/2	9.8	
64	P648M85-SF	SF	6.416	6.362	6.750	AF-1	2 5/8	5/8	1 1/2	1 1/4	1 1/4	—	3 3/4	5.40	3 1/2	13.0	
72	P728M85-E	E	7.218	7.164	7.562	AF-1	2 5/8	5/8	2	1 1/2	1 1/4	—	3 3/4	6.20	3 1/2	16.0	
80	P808M85-E	E	8.020	7.966	8.375	AF-1	2 5/8	5/8	2	1 1/2	1 1/4	—	3 3/4	6.90	3 1/2	17.0	
90	P908M85-E	E	9.023	8.969	—	A-2	2 5/8	5/8	2	1 1/2	1 1/4	—	3 3/4	7.62	—	20.0	
112	P1128M85-F	F	11.229	11.175	—	A-3	2 5/8	5/8	2	1 1/2	1 1/4	—	3 3/4	9.88	—	28.0	
144	P1448M85-F	F	14.447	14.383	—	A-3	4	3/8	3 3/8	3 1/4	3 1/4	—	3 3/4	12.88	3 1/2	79.0	
192	P1928M85-F	F	19.249	19.195	—	A-3	4	3/8	3 3/8	3 1/2	3 1/2	—	3 3/4	17.65	3 1/2	101.4	
Taper Bushed 85mm (3.35 in.) Wide Belts (8M-85)																	
34	P348M85-1615	1615	3.409	3.355	3.75	WF-1	1 1/16	3/4	1 1/2	1 1/2	—	—	3 3/4	2.750	3 1/2	3.3	
36	P368M85-1615	1615	3.609	3.555	3.94	WF-1	1 1/16	3/4	1 1/2	1 1/2	—	—	3 3/4	2.820	3 1/2	4.2	
38	P388M85-1615	1615	3.810	3.756	4.16	WF-1	1 1/16	3/4	1 1/2	1 1/2	—	—	3 3/4	3.000	3 1/2	4.7	
40	P408M85-2012	2012	4.010	3.956	4.34	WF-1	2 1/8	1 1/4	1 1/4	1 1/4	—	—	3 3/4	3.250	3 1/2	4.7	
44	P448M85-2012	2012	4.411	4.357	4.75	WF-1	2 1/4	1 1/4	1 1/4	1 1/4	—	—	3 3/4	3.500	3 1/2	6.4	
48	P488M85-2012	2012	4.812	4.758	5.16	WF-1	2 1/2	1 1/4	1 1/4	1 1/4	—	—	3 3/4	3.800	3 1/2	8.0	
56	P568M85-2517	2517	5.614	5.560	5.94	WF-1	2 5/16	1	1 3/4	1	—	—	3 3/4	4.500	3 1/2	11.0	
64	P648M85-2517	2517	6.416	6.362	6.75	WF-1	2 5/16	1	1 3/4	1	—	—	3 3/4	5.400	3 1/2	15.0	
72	P728M85-3020	3020	7.218	7.164	7.56	WF-1	3 1/4	7/8	2	7/8	—	—	3 3/4	6.200	3 1/2	18.2	
80	P808M85-3020	3020	8.020	7.966	8.38	WF-1	3 1/4	7/8	2	7/8	—	—	3 3/4	6.900	3 1/2	24.2	
90	P908M85-3020	3020	9.023	8.969	—	W-1	3 3/4	7/8	2	7/8	—	—	3 3/4	7.630	—	31.9	
112	P1128M85-3020	3020	11.229	11.175	—	W-3	3 3/4	7/8	2	7/8	—	6 1/4	3 3/4	9.880	—	34.6	
144	P1448M85-3535	3535	14.437	14.383	—	W-3	3 3/8	1/2	3 1/2	1/2	—	7	3 3/4	12.880	—	49.6	
192	P1928M85-3535	3535	19.249	19.195	—	W-3	3 3/8	1/2	3 1/2	1/2	—	7	3 3/4	17.630	—	81.4	

* Weight Shown is for Sprocket Less Bushing.
• Reverse Mount Only

+ The numbers (1=Solid, 2=Web, 3=Arms), within the "Type" indicates construction and the letter F indicates the sprocket has flanges.

14mm | High Torque Sprockets

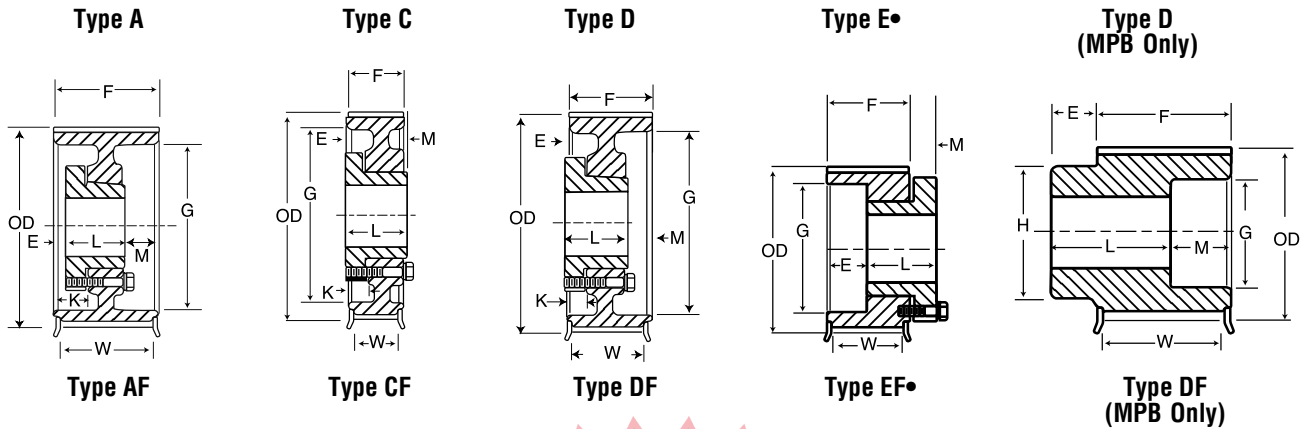

QD 40mm (1.570 in.) Wide Belts (140M-40)																
No. of Teeth	Catalog Number	Bore	P.D.	Diameter (in.)			Type +	Max. Bore	Dimensions (in.)							Weight Approx. (lbs)
				O.D.	Flange	E			L	M	K	H	F	G	W	
28	P2814M40-SK	SK	4.912	4.802	5.56	DF-1	2 5/8	3/8	1 1/8	3/8	—	—	2 1/2	3.13	1 13/16	5.5
29	P2914M40-SK	SK	5.088	4.978	5.56	• EF-1	2 5/8	7/8	1 1/4	3/8	—	—	2 1/2	3.13	1 13/16	6.5
30	P3014M40-SK	SK	5.263	5.153	6.13	DF-1	2 5/8	3/8	1 1/8	7/16	—	—	2 1/2	3.92	1 13/16	6.0
32	P3214M40-SK	SK	5.614	5.504	6.13	DF-1	2 5/8	3/8	1 1/8	7/16	3/16	—	2 1/2	3.92	1 13/16	8.0
34	P3414M40-SK	SK	5.965	5.855	6.50	DF-1	2 5/8	3/8	1 1/8	7/16	7/16	—	2 1/2	4.06	1 13/16	8.5
36	P3614M40-SF	SF	6.316	6.206	6.81	DF-1	2 5/8	3/8	2	3/8	7/16	—	2 1/2	4.69	1 13/16	9.5
38	P3814M40-SF	SF	6.667	6.557	7.16	DF-1	2 5/8	3/8	2	3/8	7/16	—	2 1/2	4.94	1 13/16	11.5
40	P4014M40-SF	SF	7.018	6.909	7.50	DF-1	2 5/8	3/8	2	3/8	7/16	—	2 1/2	5.06	1 13/16	13.0
44	P4414M40-E	E	7.720	7.610	8.22	DF-1	3 1/2	3/8	2 1/4	1/2	1/4	—	2 1/2	6.12	1 13/16	16.5
48	P4814M40-E	E	8.421	8.311	8.94	DF-1	3 1/2	3/8	2 1/4	1/2	1/4	—	2 1/2	6.50	1 13/16	20.0
52	P5214M40-E	E	9.123	9.013	9.69	DF-1	3 1/2	3/8	2 1/4	1/2	1/4	—	2 1/2	7.18	1 13/16	24.0
56	P5614M40-E	E	9.825	9.715	10.38	DF-1	3 1/2	3/8	2 1/4	1/2	1/4	—	2 1/2	7.88	1 13/16	28.0
60	P6014M40-E	E	10.527	10.417	11.06	DF-1	3 1/2	3/8	2 1/4	1/2	1/4	—	2 1/2	8.50	1 13/16	32.0
64	P6414M40-E	E	11.229	11.119	11.75	DF-2	3 1/2	3/8	2 1/4	1/2	1/4	—	2 1/2	9.25	1 13/16	29.0
68	P6814M40-E	E	11.930	11.820	12.50	DF-2	3 1/2	3/8	2 1/4	1/2	1/4	—	2 1/2	10.00	1 13/16	31.0
72	P7214M40-E	E	12.632	12.522	13.19	DF-2	3 1/2	3/8	2 1/4	1/2	1/4	—	2 1/2	10.69	1 13/16	33.0
80	P8014M40-E	E	14.036	13.926	14.63	DF-2	3 1/2	3/8	2 1/4	1/2	1/4	—	2 1/2	12.13	1 13/16	38.0
90	P9014M40-E	E	15.790	15.680	—	D-3	3 1/2	3/8	2 1/4	1/2	1/4	—	2 1/2	14.00	—	39.0
112	P11214M40-E	E	19.650	19.540	—	D-3	3 1/2	3/8	2 1/4	1/2	1/4	—	2 1/2	17.80	—	51.0
144	P14414M40-E	E	25.264	25.154	—	D-3	3 1/2	3/8	2 1/4	1/2	1/4	—	2 1/2	23.38	—	80.0
Taper Bushed 40mm (1.570 in.) Wide Belts (140M-40)																
28	P2814M40-2012	2012	4.912	4.802	5.56	KF-1	2 1/8	—	1 1/4	7/8	—	—	2 1/2	3.375	1 13/16	3.5
29	P2914M40-2012	2012	5.088	4.978	5.56	KF-1	2 1/8	—	1 1/4	7/8	—	—	2 1/2	3.375	1 13/16	3.9
30	P3014M40-2012	2012	5.263	5.153	6.13	KF-1	2 1/8	—	1 1/4	7/8	—	—	2 1/2	3.928	1 13/16	6.4
32	P3214M40-2012	2012	5.614	5.504	6.13	KF-1	2 1/8	—	1 1/4	7/8	—	—	2 1/2	3.928	1 13/16	8.0
34	P3414M40-2012	2012	5.965	5.855	6.50	KF-1	2 1/8	—	1 1/4	7/8	—	—	2 1/2	4.063	1 13/16	9.4
36	P3614M40-2517	2517	6.316	6.206	6.81	KF-1	2 1/8	—	1 1/4	3/8	—	—	2 1/2	4.688	1 13/16	10.5
38	P3814M40-2517	2517	6.667	6.557	7.16	KF-1	2 1/8	—	1 1/4	3/8	—	—	2 1/2	4.813	1 13/16	12.2
40	P4014M40-2517	2517	7.018	6.908	7.50	KF-1	2 1/8	—	1 1/4	3/8	—	—	2 1/2	5.188	1 13/16	14.2
44	P4414M40-2517	2517	7.720	7.610	8.22	KF-1	2 1/8	—	1 1/4	3/8	—	—	2 1/2	6.125	1 13/16	17.6
48	P4814M40-2517	2517	8.421	8.311	8.94	KF-1	2 1/8	—	1 1/4	3/8	—	—	2 1/2	6.500	1 13/16	22.0
52	P5214M40-2517	2517	9.123	9.013	9.69	KF-1	2 1/8	—	1 1/4	3/8	—	—	2 1/2	7.188	1 13/16	26.5
56	P5614M40-2517	2517	9.825	9.715	10.38	WF-2	2 1/8	—	1 1/4	3/8	4/8	—	2 1/2	7.875	1 13/16	21.5
60	P6014M40-3020	3020	10.527	10.417	11.06	WF-2	3 1/4	—	2	1/2	6 1/4	—	2 1/2	8.500	1 13/16	33.7
64	P6414M40-3020	3020	11.229	11.119	11.75	WF-2	3 1/4	—	2	1/2	6 1/4	—	2 1/2	9.250	1 13/16	36.5
68	P6814M40-3020	3020	11.930	11.820	12.50	WF-2	3 1/4	—	2	1/2	6 1/4	—	2 1/2	10.000	1 13/16	39.3
72	P7214M40-3020	3020	12.632	12.522	13.19	WF-2	3 1/4	—	2	1/2	6 1/4	—	2 1/2	10.688	1 13/16	42.6
80	P8014M40-3020	3020	14.036	13.926	14.63	WF-3	3 1/4	—	2	1/2	6 1/4	—	2 1/2	12.125	1 13/16	38.8
90	P9014M40-3020	3020	15.790	15.680	—	W-3	3 1/4	—	2	1/2	6 1/4	—	2 1/2	13.563	—	44.5
112	P11214M40-3020	3020	19.650	19.540	—	W-3	3 1/4	—	2	1/2	6 1/4	—	2 1/2	17.375	—	64.9
144	P14414M40-3020	3020	25.264	25.154	—	W-3	3 1/4	—	2	1/2	6 1/4	—	2 1/2	23.000	—	97.4

* Weight Shown is for Sprocket Less Bushing.
 • Reverse Mount Only

+ The numbers (1=Solid, 2=Web, 3=Arms), within the "Type" indicates construction and the letter F indicates the sprocket has flanges.

High Torque Sprockets | 14mm

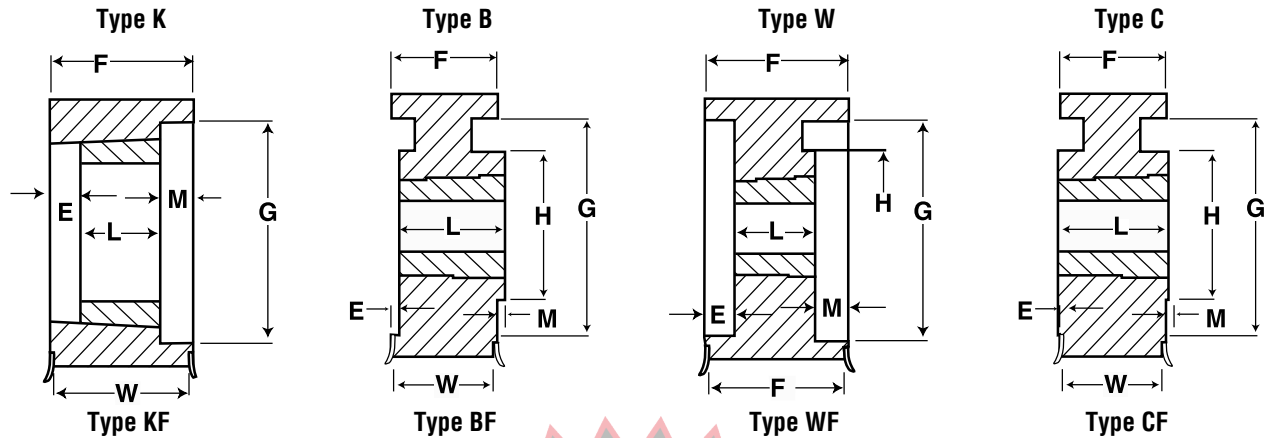

QD 55mm (2.17 in.) Wide Belts (14M-55)																
No. of Teeth	Catalog Number	Bore	P.D.	Diameter (in.)			Max. Bore	Dimensions (in.)								Weight* Approx. (lbs)
				O.D.	Flange	Type +		E	L	M	K	H	F	G	W	
28	P2814M55-SK	SK	4.912	4.808	5.56	• EF-1	2 1/2	1 1/2	1 1/2	5/8	—	—	2 1/2	3.13	2 1/8	7.0
29	P2914M55-SK	SK	5.088	4.983	5.56	• EF-1	2 1/2	1 1/2	1 1/2	5/8	—	—	2 1/2	3.13	2 1/8	8.0
30	P3014M55-SK	SK	5.263	5.157	6.13	AF-1	2 1/2	1 1/2	1 1/2	3/4	—	—	2 1/2	3.92	2 1/8	7.5
32	P3214M55-SK	SK	5.614	5.507	6.13	AF-1	2 1/2	1 1/2	1 1/2	3/4	—	—	2 1/2	3.92	2 1/8	9.0
34	P3414M55-SK	SK	5.965	5.858	6.50	AF-1	2 1/2	1 1/2	1 1/2	3/4	—	—	2 1/2	4.06	2 1/8	10.0
36	P3614M55-SF	SF	6.316	6.208	6.81	AF-1	2 1/2	1 1/2	2	5/8	—	—	2 1/2	4.69	2 1/8	11.0
38	P3814M55-SF	SF	6.667	6.559	7.16	AF-1	2 1/2	1 1/2	2	5/8	—	—	2 1/2	4.94	2 1/8	13.0
40	P4014M55-SF	SF	7.018	6.909	7.50	AF-1	2 1/2	1 1/2	2	5/8	—	—	2 1/2	5.06	2 1/8	15.0
44	P4414M55-E	E	7.720	7.610	8.22	DF-1	3 1/2	2 1/8	2 1/8	7/16	—	—	2 1/2	6.12	2 1/8	19.0
48	P4814M55-E	E	8.421	8.311	8.94	DF-1	3 1/2	2 1/8	2 1/8	7/16	—	—	2 1/2	6.50	2 1/8	23.0
52	P5214M55-E	E	9.123	9.013	9.69	DF-1	3 1/2	2 1/8	2 1/8	7/16	—	—	2 1/2	7.18	2 1/8	27.0
56	P5614M55-E	E	9.825	9.715	10.38	DF-1	3 1/2	2 1/8	2 1/8	7/16	—	—	2 1/2	7.88	2 1/8	32.0
60	P6014M55-E	E	10.527	10.417	11.06	DF-1	3 1/2	2 1/8	2 1/8	7/16	—	—	2 1/2	8.50	2 1/8	36.0
64	P6414M55-F	F	11.229	11.119	11.75	CF-1	4	3 1/8	3 1/8	0	1/8	—	2 1/2	9.25	2 1/8	53.0
68	P6814M55-F	F	11.930	11.820	12.50	DF-2	4	3 1/8	3 1/8	0	1/8	—	2 1/2	10.00	2 1/8	43.0
72	P7214M55-F	F	12.632	12.522	13.19	CF-2	4	3 1/8	3 1/8	0	1/8	—	2 1/2	10.69	2 1/8	49.0
80	P8014M55-F	F	14.036	13.926	14.63	CF-2	4	3 1/8	3 1/8	0	1/8	—	2 1/2	12.13	2 1/8	54.0
90	P9014M55-F	F	15.790	15.680	—	C-3	4	3 1/8	3 1/8	0	1/8	—	2 1/2	14.00	—	55.0
112	P11214M55-F	F	19.650	19.540	—	C-3	4	3 1/8	3 1/8	0	1/8	—	2 1/2	17.88	—	71.0
144	P14414M55-F	F	25.264	25.154	—	C-3	4	3 1/8	3 1/8	0	1/8	—	2 1/2	23.38	—	106.0
168	P16814M55-F	F	29.475	29.365	—	C-3	4	3 1/8	3 1/8	0	1/8	—	2 1/2	27.56	—	124.0
192	P19214M55-F	F	33.686	33.576	—	C-3	4	3 1/8	3 1/8	0	1/8	—	2 1/2	31.81	—	146.0
216	P21614M55-F	F	37.896	37.786	—	C-3	4	3 1/8	3 1/8	0	1/8	—	2 1/2	35.75	—	205.0
Taper Bushed 55mm (2.17 in.) Wide Belts (14M-55)																
28	P2814M55-2012	2012	4.912	4.802	5.56	KF-1	2 1/2	—	1 1/2	1 1/2	—	—	2 1/2	3.375	2 1/8	7.4
29	P2914M55-2012	2012	5.088	4.978	5.56	KF-1	2 1/2	—	1 1/2	1 1/2	—	—	2 1/2	3.375	2 1/8	8.4
30	P3014M55-2517	2517	5.263	5.153	6.13	KF-1	2 1/2	—	1 1/2	1	—	—	2 1/2	3.928	2 1/8	7.2
32	P3214M55-2517	2517	5.614	5.504	6.13	KF-1	2 1/2	—	1 1/2	1	—	—	2 1/2	3.928	2 1/8	9.3
34	P3414M55-2517	2517	5.965	5.855	6.50	KF-1	2 1/2	—	1 1/2	1	—	—	2 1/2	4.063	2 1/8	11.2
36	P3614M55-2517	2517	6.316	6.206	6.81	KF-1	2 1/2	—	1 1/2	1	—	—	2 1/2	4.688	2 1/8	12.4
38	P3814M55-2517	2517	6.667	6.557	7.16	KF-1	2 1/2	—	1 1/2	1	—	—	2 1/2	4.813	2 1/8	14.4
40	P4014M55-2517	2517	7.018	6.908	7.50	KF-1	2 1/2	—	1 1/2	1	—	—	2 1/2	5.188	2 1/8	16.7
44	P4414M55-2517	2517	7.720	7.610	8.22	KF-1	2 1/2	—	1 1/2	1	—	—	2 1/2	6.125	2 1/8	19.9
48	P4814M55-3020	3020	8.421	8.311	8.94	KF-1	3 1/2	—	2	3/4	—	—	2 1/2	6.500	2 1/8	29.2
52	P5214M55-3020	3020	9.123	9.013	9.69	KF-1	3 1/2	—	2	3/4	—	—	2 1/2	7.188	2 1/8	34.5
56	P5614M55-3020	3020	9.825	9.715	10.38	KF-1	3 1/2	—	2	3/4	—	—	2 1/2	7.875	2 1/8	40.1
60	P6014M55-3020	3020	10.527	10.417	11.06	WF-2	3 1/2	—	2	3/4	—	6 1/4	2 1/2	8.500	2 1/8	46.4
64	P6414M55-3020	3020	11.229	11.119	11.75	WF-2	3 1/2	—	2	3/4	—	6 1/4	2 1/2	9.250	2 1/8	52.7
68	P6814M55-3020	3020	11.930	11.820	12.50	WF-2	3 1/2	—	2	3/4	—	6 1/4	2 1/2	10.000	2 1/8	45.5
72	P7214M55-3020	3020	12.632	12.522	13.19	WF-2	3 1/2	—	2	3/4	—	6 1/4	2 1/2	10.688	2 1/8	49.5
80	P8014M55-3020	3020	14.036	13.926	14.63	WF-3	3 1/2	—	2	3/4	—	6 1/4	2 1/2	12.125	2 1/8	45.2
90	P9014M55-3020	3020	15.790	15.680	—	W-3	3 1/2	—	2	3/4	—	6 1/4	2 1/2	13.563	—	46.1
112	P11214M55-3020	3020	19.650	19.540	—	W-3	3 1/2	—	2	3/4	—	6 1/4	2 1/2	17.375	—	69.8
144	P14414M55-3020	3020	25.264	25.154	—	W-3	3 1/2	—	2	3/4	—	6 1/4	2 1/2	23.000	—	104.4
192	P19214M55-3535	3535	33.686	33.576	—	C-3	3 3/8	0.38	3 1/2	3/8	—	7	2 1/2	31.375	—	104.2

* Weight Shown is for Sprocket Less Bushing.
• Reverse Mount Only

+ The numbers (1=Solid, 2=Web, 3=Arms), within the "Type" indicates construction and the letter F indicates the sprocket has flanges.

14mm | High Torque Sprockets

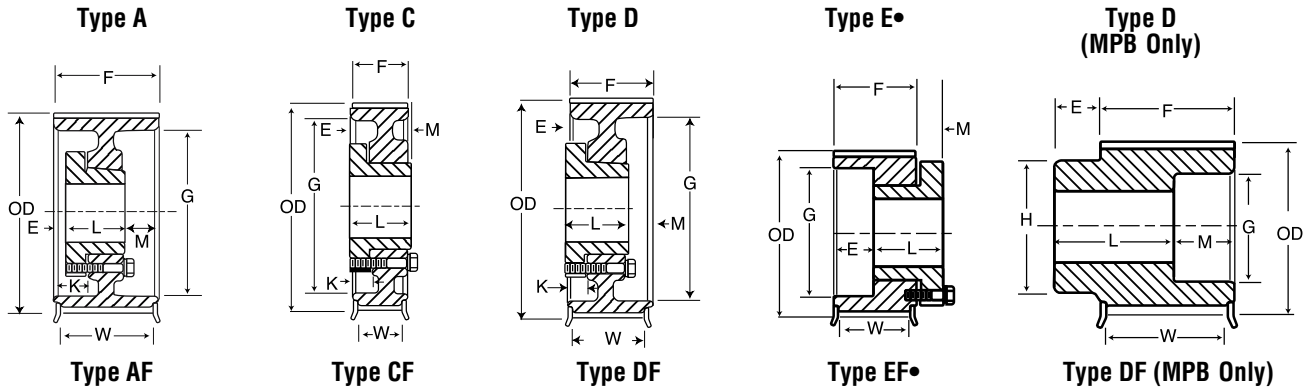

MPB 85mm (3.35in.) Wide Belts (14M-85)																
No. of Teeth	Catalog Number	Bore	P.D.	Diameter (in.)		Type +	Max. Bore	Dimensions (in.)								Weight* Approx. (lbs)
				O.D.	Flange			E	L	M	K	H	F	G	W	
28	P2814M85-MPB	1/4	4.912	4.802	5.56	DF-1	2 1/16	1	4	1	—	3 1/16	4	3.13	3 1/16	18.0
29	P2914M85-MPB	1/4	5.088	4.983	5.56	DF-1	2 1/16	1	4	1	—	3 1/16	4	3.13	3 1/16	19.4
30	P3014M85-MPB	1/4	5.263	5.157	6.13	DF-1	2 1/8	1	4	1	—	4 3/64	4	3.72	3 1/16	20.6
32	P3214M85-MPB	1/4	5.614	5.507	6.13	DF-1	2 1/8	1	4	1	—	4 3/64	4	3.72	3 1/16	23.4
34	P3414M85-MPB	1/4	5.965	5.858	6.50	DF-1	2 1/16	1	4	1	—	4 3/64	4	4.06	3 1/16	27.4
QD 85mm (3.35in.) Wide Belts (14M-85)																
30	P3014M85-SK	SK	5.293	5.157	6.13	AF-1	2 1/8	3/4	1 1/8	1 1/8	1 1/8	—	4	3.92	3 1/16	10.0
32	P3214M85-SK	SK	5.614	5.507	6.13	AF-1	2 1/8	3/4	1 1/8	1 1/8	1 1/8	—	4	3.92	3 1/16	13.0
34	P3414M85-SK	SK	5.965	5.853	6.13	AF-1	2 1/8	3/4	1 1/8	1 1/8	1 1/8	—	4	4.06	3 1/16	14.0
36	P3614M85-SF	SF	6.316	6.206	6.81	AF-1	2 1/8	3/4	2	1 1/4	1 1/8	—	4	4.69	3 1/16	15.0
38	P3814M85-SF	SF	6.667	6.557	7.16	AF-1	2 1/8	3/4	2	1 1/4	1 1/8	—	4	4.94	3 1/16	18.0
40	P4014M85-SF	SF	7.018	6.909	7.50	AF-1	2 1/8	3/4	2	1 1/4	1 1/8	—	4	5.06	3 1/16	20.0
44	P4414M85-E	E	7.720	7.610	8.22	AF-1	3 1/2	3/8	2 1/2	1 1/16	1 1/16	—	4	6.12	3 1/16	25.0
48	P4814M85-E	E	8.421	8.311	8.94	AF-1	3 1/2	3/8	2 1/2	1 1/16	1 1/16	—	4	6.50	3 1/16	29.0
52	P5214M85-E	E	9.123	9.013	9.69	AF-1	3 1/2	3/8	2 1/2	1 1/16	1 1/16	—	4	7.18	3 1/16	32.0
56	P5614M85-F	F	9.825	9.715	10.38	DF-1	4	1/4	3 3/8	3/8	3/8	—	4	7.88	3 1/16	46.0
60	P6014M85-F	F	10.527	10.417	11.06	DF-1	4	1/4	3 3/8	3/8	3/8	—	4	8.50	3 1/16	51.0
64	P6414M85-F	F	11.229	11.119	11.75	DF-1	4	1/4	3 3/8	3/8	3/8	—	4	9.25	3 1/16	62.0
68	P6814M85-F	F	11.930	11.820	12.50	DF-2	4	1/4	3 3/8	3/8	3/8	—	4	10.00	3 1/16	51.0
72	P7214M85-F	F	12.632	12.522	13.19	DF-2	4	1/4	3 3/8	3/8	3/8	—	4	10.688	3 1/16	60.0
80	P8014M85-F	F	14.036	13.926	14.63	DF-2	4	1/4	3 3/8	3/8	3/8	—	4	12.13	3 1/16	66.0
90	P9014M85-F	F	15.790	15.680	—	D-3	4	1/4	3 3/8	3/8	3/8	—	4	14.00	—	69.0
112	P11214M85-F	F	19.650	19.540	—	D-3	4	1/4	3 3/8	3/8	3/8	—	4	17.88	—	89.0
144	P14414M85-F	F	25.264	25.154	—	D-3	4	1/4	3 3/8	3/8	3/8	—	4	23.38	—	127.0
168	P16814M85-J	J	29.475	29.365	—	D-3	4 1/2	1/4	3 3/8	3/8	3/8	—	4	27.56	—	148.0
192	P19214M85-J	J	33.686	33.576	—	D-3	4 1/2	1/4	3 3/8	3/8	3/8	—	4	31.81	—	177.0
216	P21614M85-J	J	37.896	37.786	—	D-3	4 1/2	1/4	3 3/8	3/8	3/8	—	4	35.75	—	251.0
Taper Bushed 85mm (3.35in.) Wide Belts (14M-85)																
30	P3014M85-2517	2517	5.263	5.153	6.13	WF-1	2 1/8	1/2	1 1/4	1 1/4	—	—	4	3.928	3 1/16	9.7
32	P3214M85-2517	2517	5.614	5.504	6.13	WF-1	2 1/16	7/8	1 1/4	1 1/4	—	—	4	3.928	3 1/16	12.7
34	P3414M85-2517	2517	5.965	5.855	6.50	WF-1	2 1/16	7/8	1 1/4	1 1/4	—	—	4	4.063	3 1/16	15.3
36	P3614M85-3020	3020	6.316	6.206	6.81	WF-1	3 1/4	1 1/32	2	1 1/32	—	—	4	4.688	3 1/16	19.3
38	P3814M85-3020	3020	6.667	6.557	7.16	WF-1	3 1/4	1 1/32	2	1 1/32	—	—	4	4.813	3 1/16	21.9
40	P4014M85-3020	3020	7.018	6.908	7.50	WF-1	3 1/4	1 1/32	2	1 1/32	—	—	4	5.063	3 1/16	25.1
44	P4414M85-3020	3020	7.720	7.610	8.22	WF-1	3 1/4	1 1/32	2	1 1/32	—	—	4	6.125	3 1/16	28.4
48	P4814M85-3020	3020	8.421	8.311	8.94	WF-1	3 1/4	1 1/32	2	1 1/32	—	—	4	6.500	3 1/16	35.4
52	P5214M85-3535	3535	9.123	9.013	9.69	KF-1	3 15/16	—	3 1/2	1/2	—	—	4	7.188	3 1/16	42.9
56	P5614M85-3535	3535	9.825	9.715	10.38	KF-1	3 15/16	—	3 1/2	1/2	—	—	4	7.875	3 1/16	52.4
60	P6014M85-3535	3535	10.527	10.417	11.06	KF-1	3 15/16	—	3 1/2	1/2	—	—	4	8.500	3 1/16	62.7
64	P6414M85-3535	3535	11.229	11.119	11.75	KF-1	3 15/16	—	3 1/2	1/2	—	—	4	9.250	3 1/16	73.6
68	P6814M85-3535	3535	11.930	11.820	12.50	KF-1	3 15/16	—	3 1/2	1/2	—	—	4	10.000	3 1/16	64.2
72	P7214M85-3535	3535	12.632	12.522	13.19	KF-1	3 15/16	—	3 1/2	1/2	—	—	4	10.688	3 1/16	97.4
80	P8014M85-3535	3535	14.036	13.926	14.63	WF-2	3 15/16	—	3 1/2	1/2	—	—	4	12.125	3 1/16	68.4
90	P9014M85-3535	3535	15.790	15.680	—	W-3	3 15/16	—	3 1/2	1/2	—	7	4	13.563	—	69.1
112	P11214M85-3535	3535	19.650	19.540	—	W-3	3 15/16	—	3 1/2	1/2	—	7	4	17.375	—	85.7
144	P14414M85-4040	4040	25.264	25.154	—	W-3	4 1/16	—	4	—	—	8 1/2	4	23.000	—	131.6
168	P16814M85-4040	4040	29.475	29.365	—	W-3	4 1/16	—	4	—	—	8 1/2	4	27.250	—	146.1
192	P19214M85-4040	4040	33.686	33.576	—	W-3	4 1/16	—	4	—	—	8 1/2	4	31.375	—	161.4

* Weight Shown is for Sprocket Less Bushing.
• Reverse Mount Only

+ The numbers (1=Solid, 2=Web, 3=Arms), within the "Type" indicates construction and the letter F indicates the sprocket has flanges.

High Torque Sprockets | 14mm

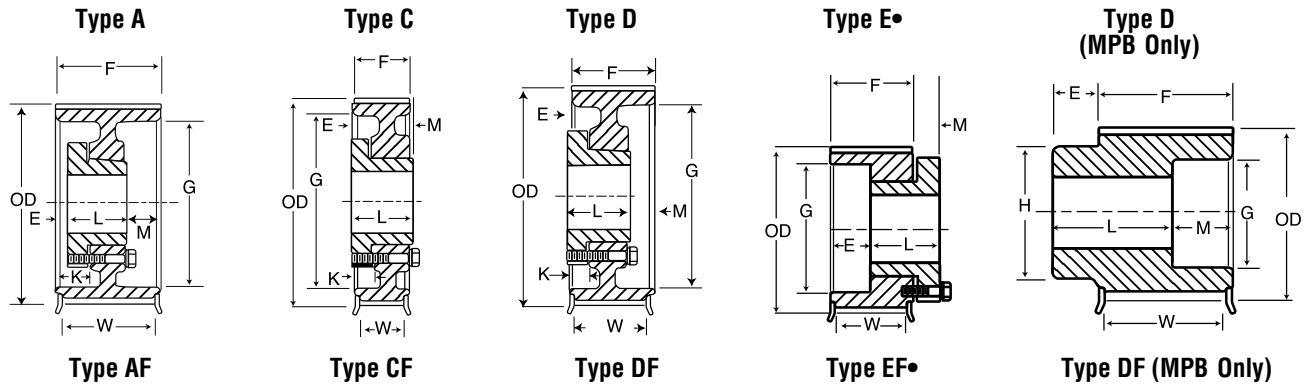

MPB 115mm (4.53 in.) Wide Belts (14M-115)																
No. of Teeth	Catalog Number	Bore	P.D.	Diameter (in.)			Type +	Max. Bore	Dimensions (in.)			F	G	W	Weight* Approx. (lbs)	
				O.D.	Flange	E			L	M	K					H
28	P2814M115-MPB	1/4	4.912	4.808	5.56	DF-1	2 3/16	1 1/4	5	1 1/2	—	3 1/16	5 1/4	3.13	4 3/16	23.2
29	P2914M115-MPB	1/4	5.088	4.983	5.56	DF-1	2 3/16	1 1/4	5	1 1/2	—	3 1/16	5 1/4	3.13	4 3/16	24.8
30	P3014M115-MPB	1/4	5.263	5.157	6.13	DF-1	2 1/2	1 1/4	5	1 1/2	—	4 3/16	5 1/4	3.90	4 3/16	26.4
32	P3214M115-MPB	1/4	5.614	5.507	6.13	DF-1	2 1/2	1 1/4	5	1 1/2	—	4 3/16	5 1/4	3.90	4 3/16	30.8
34	P3414M115-MPB	1/4	5.965	5.858	6.50	DF-1	2 11/16	1 1/4	5	1 1/2	—	4 3/16	5 1/4	4.06	4 3/16	35.2
36	P3614M115-MPB	1/4	6.316	6.208	6.81	DF-1	3	1 1/4	5	1 1/2	—	4 7/16	5 1/4	4.69	4 3/16	38.8
38	P3814M115-MPB	1/4	6.667	6.559	7.16	DF-1	3 1/4	1 1/4	5	1 1/2	—	5 1/16	5 1/4	4.94	4 3/16	44.4
40	P4014M115-MPB	1/4	7.018	6.909	7.50	DF-1	3 3/16	1 1/4	5	1 1/2	—	5 1/16	5 1/4	5.06	4 3/16	50.0
QD 115mm (4.53 in.) Wide Belts (14M-115)																
30	P3014M115-SK	1/4	5.263	5.157	6.13	AF-1	2 3/8	1 1/8	1 1/8	2	2	—	5 1/4	3.92	4 3/16	12.0
32	P3214M115-SK	1/4	5.614	5.507	6.13	AF-1	2 3/8	1 1/8	1 1/8	2	2	—	5 1/4	3.92	4 3/16	16.0
34	P3414M115-SK	1/4	5.965	5.858	6.50	AF-1	2 7/8	1 1/8	1 1/8	2	2	—	5 1/4	4.06	4 3/16	17.0
36	P3614M115-SF	1/4	6.316	6.208	6.81	AF-1	3	1 3/8	2	1 7/8	2	—	5 1/4	4.69	4 3/16	18.0
38	P3814M115-SF	1/4	6.667	6.559	7.16	AF-1	3	1 3/8	2	1 7/8	2	—	5 1/4	4.94	4 3/16	22.0
40	P4014M115-SF	1/4	7.018	6.909	7.50	AF-1	3	1 3/8	2	1 7/8	2	—	5 1/4	5.06	4 3/16	25.0
44	P4414M115-E	E	7.720	7.610	8.22	AF-1	3 1/2	1 1/8	2 3/8	1 11/16	1 3/16	—	5 1/4	6.12	4 3/16	30.0
48	P4814M115-E	E	8.421	8.311	8.94	AF-1	3 1/2	1 1/8	2 3/8	1 11/16	1 3/16	—	5 1/4	6.50	4 3/16	35.0
52	P5214M115-F	F	9.123	9.013	9.69	AF-1	4	3/8	3 3/8	1 1/4	1 1/8	—	5 1/4	7.18	4 3/16	42.0
56	P5614M115-F	F	9.825	9.715	10.38	AF-1	4	3/8	3 3/8	1 1/4	1 1/8	—	5 1/4	7.88	4 3/16	53.0
60	P6014M115-F	F	10.527	10.417	11.06	AF-1	4 1/2	3/8	3 3/8	1 1/4	1 1/8	—	5 1/4	8.50	4 3/16	60.0
64	P6414M115-J	J	11.229	11.119	11.75	DF-1	4 1/2	3/8	4 1/2	1 1/8	1	—	5 1/4	9.25	4 3/16	76.0
68	P6814M115-J	J	11.930	11.820	12.50	DF-1	4 1/2	3/8	4 1/2	1 1/8	1	—	5 1/4	10.00	4 3/16	83.0
72	P7214M115-J	J	12.632	12.522	13.19	DF-1	4 1/2	3/8	4 1/2	1 1/8	1	—	5 1/4	10.69	4 3/16	99.0
80	P8014M115-J	J	14.036	13.926	14.63	DF-2	4 1/2	3/8	4 1/2	1 1/8	1	—	5 1/4	12.13	4 3/16	87.0
90	P9014M115-J	J	15.790	15.680	—	D-2	4 1/2	3/8	4 1/2	1 1/8	1	—	5 1/4	14.00	—	95.0
112	P11214M115-J	J	19.650	19.540	—	D-3	4 1/2	3/8	4 1/2	1 1/8	1	—	5 1/4	17.88	—	114.0
144	P14414M115-J	J	25.264	25.154	—	D-3	4 1/2	3/8	4 1/2	1 1/8	1	—	5 1/4	23.38	—	166.0
168	P16814M115-M	M	29.475	29.365	—	D-3	5 1/8	3/8	4 1/2	1 1/8	1	—	5 1/4	27.56	—	198.0
192	P19214M115-M	M	33.686	33.576	—	D-3	5 1/2	3/8	4 1/2	1 1/8	1	—	5 1/4	31.81	—	232.0
216	P21614M115-M	M	37.896	37.786	—	D-3	5 1/2	3/8	4 1/2	1 1/8	1	—	5 1/4	35.75	—	307.0
Taper Bushed 115mm (4.53 in.) Wide Belts (14M-115)																
30	P3014M115-2517	2517	5.263	5.153	6.13	WF-1	2 11/16	1 1/4	1 1/4	1 1/4	—	—	5 1/4	3.928	4 3/16	13.5
32	P3214M115-2517	2517	5.614	5.504	6.13	WF-1	2 11/16	1 1/4	1 1/4	1 1/4	—	—	5 1/4	3.928	4 3/16	17.3
34	P3414M115-2517	2517	5.965	5.855	6.50	WF-1	2 11/16	1 1/4	1 1/4	1 1/4	—	—	5 1/4	4.063	4 3/16	20.9
36	P3614M115-3020	3020	6.316	6.206	6.81	WF-1	3 1/4	1 1/4	2	1 1/4	—	—	5 1/4	4.688	4 3/16	18.6
38	P3814M115-3020	3020	6.667	6.557	7.16	WF-1	3 1/4	1 1/4	2	1 1/4	—	—	5 1/4	4.813	4 3/16	22.5
40	P4014M115-3020	3020	7.018	6.908	7.50	WF-1	3 3/4	1 1/4	2	1 1/4	—	—	5 1/4	5.063	4 3/16	26.8
44	P4414M115-3535	3535	7.720	7.610	8.22	WF-1	3 11/16	7/8	3 1/2	7/8	—	—	5 1/4	6.125	4 3/16	30.8
48	P4814M115-3535	3535	8.421	8.311	8.94	WF-1	3 11/16	7/8	3 1/2	7/8	—	—	5 1/4	6.500	4 3/16	41.1
52	P5214M115-4040	4040	9.123	9.013	9.69	WF-1	4 1/8	3/4	4	3/4	—	—	5 1/4	7.188	4 3/16	46.9
56	P5614M115-4040	4040	9.825	9.715	10.38	WF-1	4 1/8	3/4	4	3/4	—	—	5 1/4	7.875	4 3/16	58.3
60	P6014M115-4040	4040	10.527	10.417	11.06	WF-1	4 3/8	3/4	4	3/4	—	—	5 1/4	8.500	4 3/16	70.9
64	P6414M115-4545	4545	11.229	11.119	11.75	WF-1	4 11/16	3/4	4 1/2	3/4	—	—	5 1/4	9.250	4 3/16	82.1
68	P6814M115-4545	4545	11.930	11.820	12.50	WF-1	4 11/16	3/4	4 1/2	3/4	—	—	5 1/4	10.000	4 3/16	97.1
72	P7214M115-4545	4545	12.632	12.522	13.19	WF-1	4 11/16	3/4	4 1/2	3/4	—	—	5 1/4	10.688	4 3/16	113.3
80	P8014M115-4545	4545	14.036	13.926	14.63	WF-2	4 11/16	3/4	4 1/2	3/4	9 1/2	—	5 1/4	12.125	4 3/16	108.9
90	P9014M115-4545	4545	15.790	15.680	—	W-2	4 11/16	3/4	4 1/2	3/4	9 1/2	—	5 1/4	13.563	—	112.9
112	P11214M115-4545	4545	19.650	19.540	—	W-3	4 11/16	3/4	4 1/2	3/4	9 1/2	—	5 1/4	17.375	—	122.4
144	P14414M115-4545	4545	25.264	25.154	—	W-3	4 11/16	3/4	4 1/2	3/4	9 1/2	—	5 1/4	23.000	—	155.0
168	P16814M115-4545	4545	29.475	29.365	—	W-3	4 11/16	3/4	4 1/2	3/4	9 1/2	—	5 1/4	27.250	—	188.0
192	P19214M115-4545	4545	33.686	33.576	—	W-3	4 11/16	3/4	4 1/2	3/4	9 1/2	—	5 1/4	31.375	—	318.8
216	P21614M115-6050	6050	37.896	37.786	—	W-3	6	—	5	1/4	15 1/2	—	5 1/4	35.625	—	350.3

* Weight Shown is for Sprocket Less Bushing.
• Reverse Mount Only

+ The numbers (1=Solid, 2=Web, 3=Arms) within the "Type" indicates construction, and the letter F indicates the sprocket has flanges.

14mm | High Torque Sprockets

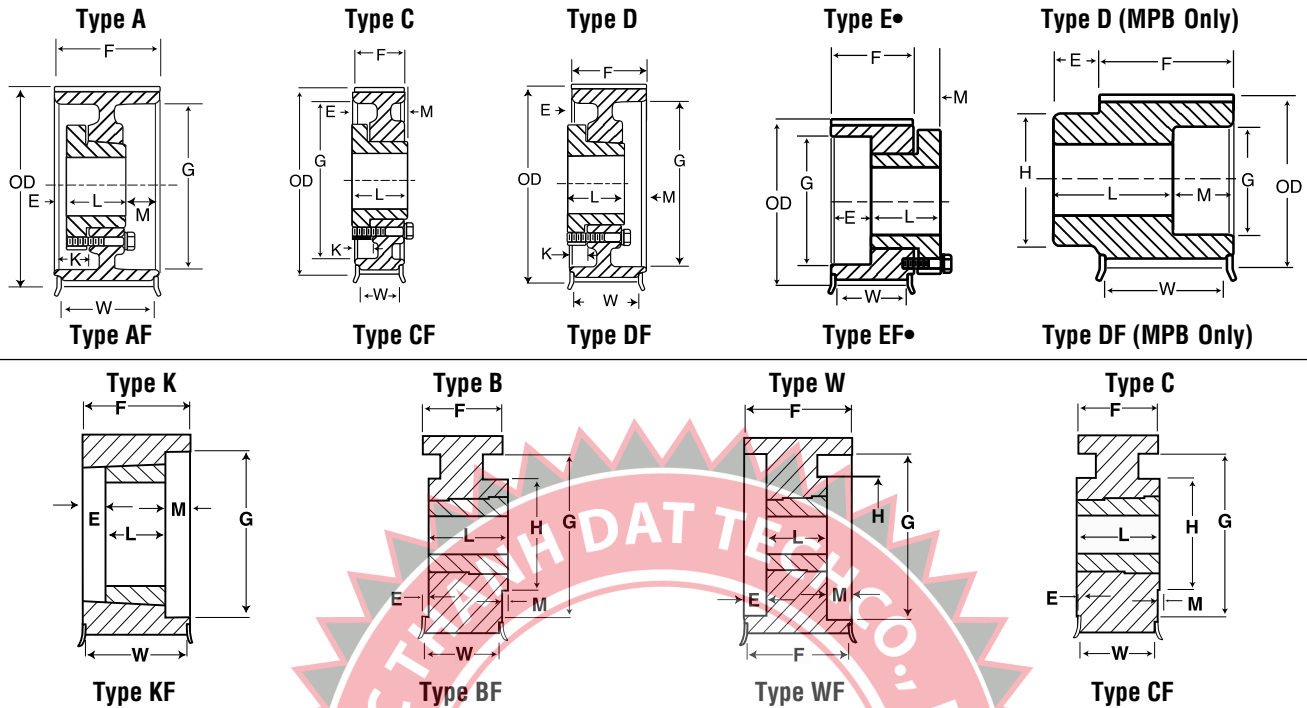

MPB 170mm (6.69 in.) Wide Belts (14M-170)																
No. of Teeth	Catalog Number	Bore	Pitch Diameter	Diameter (in.)			Type +	Max. Bore	Dimensions (in.)							Weight* Approx. (lbs)
				O.D.	Flange	E			L	M	K	H	F	G	W	
36	P3614M170-MPB	1½	6.316	6.208	6.81	DF-1	3	1¼	6	2½	—	4⅞	7⅞	4.69	7⅞	47.0
38	P3814M170-MPB	1½	6.667	6.559	7.16	DF-1	3¼	1¼	6	2½	—	5⅞	7⅞	4.94	7⅞	55.7
40	P4014M170-MPB	1½	7.018	6.909	7.50	DF-1	3⅞	1¼	6	2½	—	5⅞	7⅞	5.06	7⅞	63.7
44	P4414M170-MPB	1½	7.720	7.610	8.22	DF-1	4¾	1¼	6	2½	—	6⅞	7⅞	6.13	7⅞	75.7
48	P4814M170-MPB	1½	8.421	8.311	8.94	DF-1	4½	1¼	6	2½	—	6⅞	7⅞	6.50	7⅞	94.0
QD 170mm (6.69 in.) Wide Belts (14M-170)																
44	P4414M170-E	E	7.720	7.610	8.22	AF-1	3⅞	2	2½	2¼	—	7⅞	6.12	7⅞	38.0	
48	P4814M170-E	E	8.421	8.311	8.94	AF-1	3⅞	2	2½	2¼	—	7⅞	6.50	7⅞	45.0	
52	P5214M170-F	F	9.123	9.013	9.69	AF-1	4	1⅞	3⅞	2⅞	—	7⅞	7.18	7⅞	52.0	
56	P5614M170-F	F	9.825	9.715	10.38	AF-1	4	1⅞	3⅞	2⅞	—	7⅞	7.88	7⅞	65.0	
60	P6014M170-J	J	10.527	10.417	11.06	AF-1	4½	1⅞	4½	1⅞	—	7⅞	8.50	7⅞	75.0	
64	P6414M170-J	J	11.229	11.119	11.75	AF-1	4½	1⅞	4½	1⅞	—	7⅞	9.25	7⅞	91.0	
68	P6814M170-J	J	11.930	11.820	12.50	AF-1	4½	1⅞	4½	1⅞	—	7⅞	10.00	7⅞	96.0	
72	P7214M170-J	J	12.632	12.522	13.19	AF-1	4½	1⅞	4½	1⅞	—	7⅞	10.69	7⅞	115.0	
80	P8014M170-J	J	14.036	13.926	14.63	AF-2	4½	1⅞	4½	1⅞	—	7⅞	12.13	7⅞	107.0	
90	P9014M170-J	J	15.790	15.680	—	A-2	4½	1⅞	4½	1⅞	—	7⅞	14.00	—	116.0	
112	P11214M170-M	M	19.650	19.540	—	A-3	5½	—	6¾	¾	1⅞	—	7⅞	17.88	—	175.0
144	P14414M170-M	M	25.264	25.154	—	A-3	5½	—	6¾	¾	1⅞	—	7⅞	23.38	—	240.0
168	P16814M170-M	M	29.475	29.365	—	A-3	5½	—	6¾	¾	1⅞	—	7⅞	27.56	—	278.0
192	P19214M170-M	M	33.686	33.576	—	A-3	5½	—	6¾	¾	1⅞	—	7⅞	31.81	—	322.0
216	P21614M170-M	M	37.896	37.786	—	A-3	5½	—	6¾	¾	1⅞	—	7⅞	35.75	—	399.0
Taper Bushed 170mm (6.69 in.) Wide Belts (14M-170)																
44	P4414M170-3535	3535	7.720	7.610	8.22	WF-1	3⅞	1⅞	3½	1⅞	—	—	7⅞	6.13	7⅞	39.7
48	P4814M170-3535	3535	8.421	8.311	8.94	WF-1	3⅞	1⅞	3½	1⅞	—	—	7⅞	6.50	7⅞	52.8
52	P5214M170-4040	4040	9.123	9.013	9.69	WF-1	4	1⅞	4	1⅞	—	—	7⅞	7.19	7⅞	59.8
56	P5614M170-4040	4040	9.825	9.715	10.38	WF-1	4	1⅞	4	1⅞	—	—	7⅞	7.88	7⅞	72.4
60	P6014M170-4545	4545	10.527	10.417	11.06	WF-1	4	1⅞	4	1⅞	—	—	7⅞	8.50	7⅞	83.7
64	P6414M170-4545	4545	11.229	11.119	11.75	WF-1	4⅞	1⅞	4½	1⅞	—	—	7⅞	9.25	7⅞	98.6
68	P6814M170-4545	4545	11.930	11.820	12.50	WF-1	4⅞	1⅞	4½	1⅞	—	—	7⅞	10.00	7⅞	114.4
72	P7214M170-4545	4545	12.632	12.522	13.19	WF-1	4⅞	1⅞	4½	1⅞	—	—	7⅞	10.69	7⅞	131.8
80	P8014M170-4545	4545	14.036	13.926	14.63	WF-2	4⅞	1⅞	4½	1⅞	—	9½	7⅞	12.13	7⅞	129.3
90	P9014M170-4545	4545	15.790	15.680	—	W-2	4⅞	1⅞	4½	1⅞	—	9½	7⅞	13.56	—	126.8
112	P11214M170-4545	4545	19.650	19.540	—	W-3	4⅞	1⅞	4½	1⅞	—	9½	7⅞	17.38	—	148.0
144	P14414M170-6050	6050	25.264	25.154	—	W-3	6	1⅞	5	1⅞	—	15½	7⅞	23.00	—	208.0
168	P16814M170-6050	6050	29.475	29.365	—	W-3	6	1⅞	5	1⅞	—	15½	7⅞	27.25	—	227.0
192	P19214M170-6050	6050	33.686	33.576	—	W-3	6	1⅞	5	1⅞	—	15½	7⅞	31.38	—	340.0
216	P21614M170-6050	6050	37.896	37.786	—	W-3	6	1⅞	5	1⅞	—	15½	7⅞	35.63	—	390.0

* Weight Shown is for Sprocket Less Bushing.
• Reverse Mount Only

+ The numbers (1=Solid, 2=Web, 3=Arms), within the "Type" indicates construction and the letter F indicates the sprocket has flanges.

High Torque Sprockets | 20mm

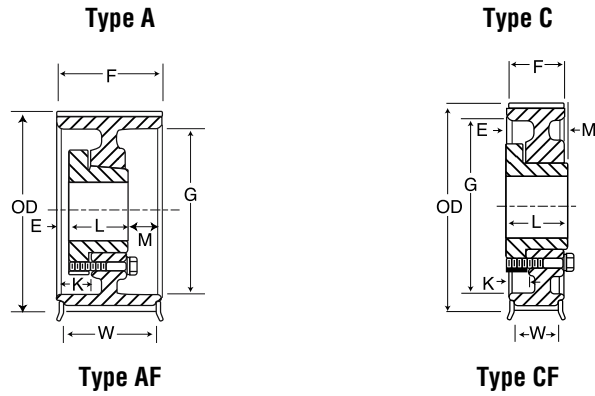

QD 115mm (4.53 in.) Wide Belts (20M-115)

No. of Teeth	Catalog Number	Bore	Pitch Diameter	Diameter (in.)			Type +	Max. Bore	Dimensions (in.)							Weight* Approx. (lbs)
				O.D.	Flange				E	L	M	K	H	F	G	
34	P3420M115-F	F	8.522	8.352	9.449	AF-1	4.00	0.44	3.63	1.31	1.44	—	5.38	6.88	5.0	32.0
36	P3620M115-F	F	9.023	8.853	9.843	AF-1	4.00	0.44	3.63	1.31	1.44	—	5.38	7.00	5.0	40.0
38	P3820M115-F	F	9.524	9.354	10.433	AF-1	4.00	0.44	3.63	1.31	1.44	—	5.38	7.56	5.0	45.0
40	P4020M115-F	F	10.026	9.856	10.827	AF-1	4.00	0.44	3.63	1.31	1.44	—	5.38	8.00	5.0	51.0
44	P4420M115-F	F	11.028	10.858	11.811	AF-1	4.00	0.44	3.63	1.31	1.44	—	5.38	8.93	5.0	63.0
48	P4820M115-J	J	12.031	11.861	12.795	AF-1	4.50	0.00	4.50	0.88	1.18	—	5.38	9.93	5.0	84.0
52	P5220M115-J	J	13.033	12.863	13.764	AF-2	4.50	0.00	4.50	0.88	1.18	—	5.38	10.88	5.0	80.0
56	P5620M115-J	J	14.036	13.866	14.764	AF-2	4.50	0.00	4.50	0.88	1.18	—	5.38	11.88	5.0	87.0
60	P6020M115-J	J	15.038	14.868	15.927	AF-2	4.50	0.00	4.50	0.88	1.18	—	5.38	13.06	5.0	94.0
64	P6420M115-J	J	16.041	15.871	16.929	AF-2	4.50	0.00	4.50	0.88	1.18	—	5.38	14.06	5.0	104.0
68	P6820M115-J	J	17.044	16.874	17.927	AF-2	4.50	0.00	4.50	0.88	1.18	—	5.38	15.00	5.0	110.0
72	P7220M115-J	J	18.046	17.876	18.898	AF-2	4.50	0.00	4.50	0.88	1.18	—	5.38	16.00	5.0	119.0
80	P8020M115-M	M	20.051	19.881	20.866	CF-2	5.50	1.25	6.75	0.12	0.18	—	5.38	18.00	5.0	182.0
90	P9020M115-M	M	22.558	22.388	23.425	CF-2	5.50	1.25	6.75	0.12	0.18	—	5.38	20.56	5.0	212.0
112	P11220M115-M	M	28.072	27.902	—	C-3	5.50	1.25	6.75	0.12	0.18	—	5.38	26.38	—	239.0
144	P14420M115-N	N	36.092	35.922	—	C-3	5.87	1.75	8.12	1.00	0.00	—	5.38	34.38	—	341.0
168	P16820M115-N	N	42.108	41.938	—	C-3	5.87	1.75	8.12	1.00	0.00	—	5.38	40.38	—	417.0
192	P19220M115-N	N	48.123	47.953	—	C-3	5.87	1.75	8.12	1.00	0.00	—	5.38	46.25	—	500.0
216	P21620M115-N	N	54.138	53.968	—	C-3	5.77	1.75	8.12	1.00	0.00	—	5.38	52.25	—	566.0

* Weight Shown is for Sprocket less Bushing.
 • Reverse Mount Only

+ The numbers (1=Solid, 2=Web, 3=Arms), within the "Type" indicates construction and the letter F indicates the sprocket has flanges.

20mm | High Torque Sprockets

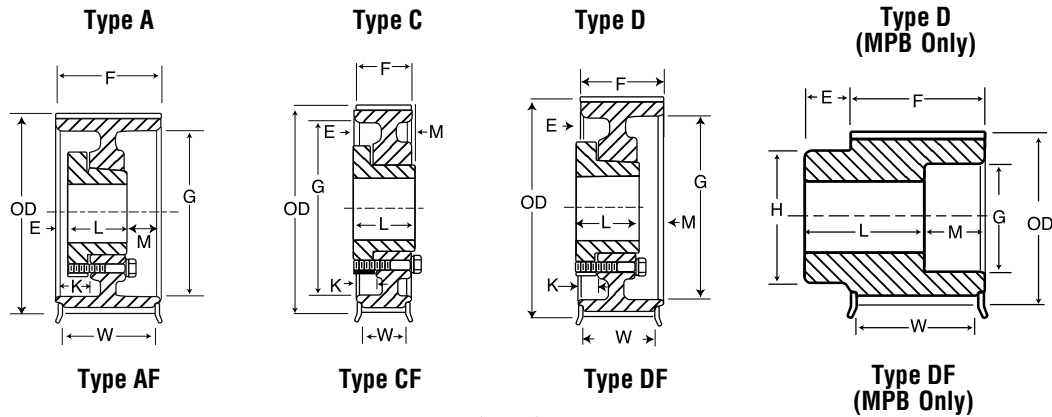

QD 170mm (6.69 in.) Wide Belts (20M-170)

No. of Teeth	Catalog Number	Bore	Pitch Diameter	Diameter (in.)		Type +	Max. Bore	Dimensions (in.)							Weight* Approx. (lbs)	
				O.D.	Flange			E	L	M	K	H	F	G		W
34	P3420M170-MPB	2%	8.522	8.352	9.449	DF-1	4.38	1.25	6.50	2.25	—	6.50	7.50	6.50	7.12	82.0
36	P3620M170-MPB	2%	9.023	8.853	9.843	DF-1	4.50	1.25	6.50	2.25	—	7.00	7.50	7.00	7.12	93.0

MPB 170mm (6.69 in.) Wide Belts (20M-170)

38	P3820M170-J	J	9.524	9.354	10.433	AF-1	4.50	1.00	4.50	2.00	2.18	—	7.50	7.56	7.12	56.0
40	P4020M170-J	J	10.026	9.856	10.827	AF-1	4.50	1.00	4.50	2.00	2.18	—	7.50	8.00	7.12	64.0
44	P4420M170-J	J	11.028	10.858	11.811	AF-1	4.50	1.00	4.50	2.00	2.18	—	7.50	8.93	7.12	81.0
48	P4820M170-M	M	12.031	11.861	12.795	AF-1	5.50	0.06	6.75	0.68	1.50	—	7.50	9.93	7.12	113.0
52	P5220M170-M	M	13.033	12.863	13.764	AF-1	5.50	0.06	6.75	0.68	1.50	—	7.50	10.88	7.12	141.0
56	P5620M170-M	M	14.036	13.866	14.764	AF-1	5.50	0.06	6.75	0.68	1.50	—	7.50	11.88	7.12	170.0
60	P6020M170-M	M	15.038	14.868	15.927	AF-1	5.50	0.06	6.75	0.68	1.50	—	7.50	13.06	7.12	199.0
64	P6420M170-M	M	16.041	15.871	16.929	AF-2	5.50	0.06	6.75	0.68	1.50	—	7.50	14.06	7.12	175.0
68	P6820M170-M	M	17.044	16.874	17.927	AF-2	5.50	0.06	6.75	0.68	1.50	—	7.50	15.00	7.12	187.0
72	P7220M170-M	M	18.046	17.876	18.898	AF-2	5.50	0.06	6.75	0.68	1.50	—	7.50	16.00	7.12	196.0
80	P8020M170-M	M	20.051	19.881	20.866	AF-2	5.50	0.06	6.75	0.68	1.50	—	7.50	18.00	7.12	214.0
90	P9020M170-M	M	22.558	22.388	23.425	AF-2	5.50	0.06	6.75	0.68	1.50	—	7.50	20.56	7.12	250.0
112	P11220M170-N	N	28.072	27.902	—	C-3	5.87	0.50	8.12	0.12	1.25	—	7.50	26.25	7.12	309.0
144	P14420M170-N	N	36.092	35.922	—	C-3	5.87	0.50	8.12	0.12	1.25	—	7.50	34.25	—	426.0
168	P16820M170-P	P	42.108	41.938	—	C-3	7.00	0.90	9.38	0.94	1.06	—	7.50	40.25	—	571.0
192	P19220M170-P	P	48.123	47.953	—	C-3	7.00	0.94	9.38	0.94	1.06	—	7.50	46.25	—	652.0
216	P21620M170-P	P	54.138	53.968	—	C-3	7.00	0.94	9.38	0.94	1.06	—	7.50	52.12	—	813.0

* Weight Shown is for Sprocket less Bushing.
• Reverse Mount Only

+ The numbers (1=Solid, 2=Web, 3=Arms), within the "Type" indicates construction and the letter F indicates the sprocket has flanges.

High Torque Sprockets | 20mm

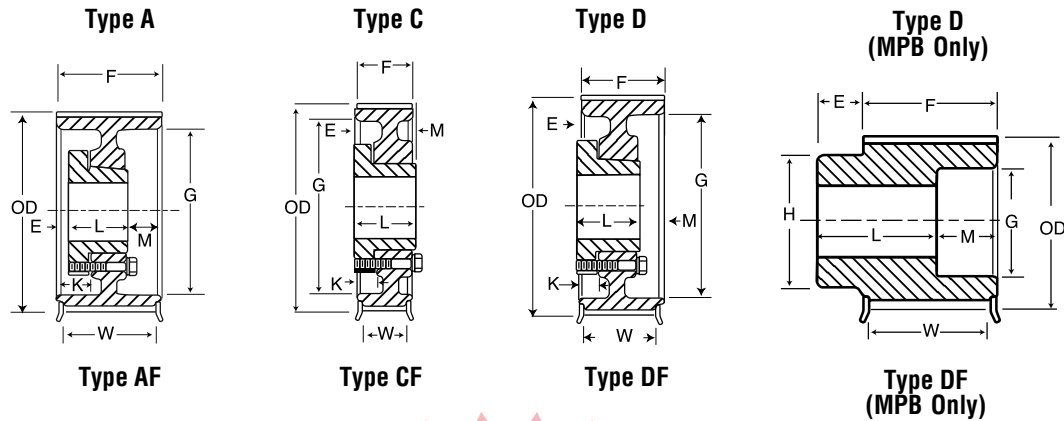

MPB 230mm (9.06 in.) Wide Belts (20M-230)

No. of Teeth	Catalog Number	Bore	Pitch Diameter	Diameter (in.)			Type +	Max. Bore	Dimensions (in.)							Weight* Approx. (lbs)
				O.D.	Flange				E	L	M	K	H	F	G	
38	P3820M230-MPB	2%	9.524	9.354	10.433	DF-1	4.75	1.25	7.50	3.63	—	7.50	9.88	7.56	9.50	120.0
40	P4020M230-MPB	2%	10.026	9.856	10.827	DF-1	5.25	1.25	8.50	2.63	—	8.00	9.88	8.00	9.50	147.0
44	P4420M230-MPB	2%	11.028	10.858	11.811	DF-1	5.25	1.25	8.50	2.63	—	8.25	9.88	8.93	9.50	180.0

QD 230mm (9.06 in.) Wide Belts (20M-230)

48	P4820M230-M	M	12.031	11.861	12.795	AF-1	5.50	0.56	6.75	2.56	2.00	—	9.88	9.93	9.50	129.0
52	P5220M230-M	M	13.033	12.863	13.764	AF-1	5.50	0.56	6.75	2.56	2.00	—	9.88	10.88	9.50	158.0
56	P5620M230-M	M	14.036	13.866	14.764	AF-1	5.50	0.56	6.75	2.56	2.00	—	9.88	11.88	9.50	189.0
60	P6020M230-M	M	15.038	14.868	15.927	AF-1	5.50	0.56	6.75	2.56	2.00	—	9.88	13.06	9.50	217.0
64	P6420M230-M	M	16.041	15.871	16.929	AF-2	5.50	0.56	6.75	2.56	2.00	—	9.88	14.06	9.50	198.0
68	P6820M230-N	N	17.044	16.874	17.927	AF-1	5.87	0.06	8.12	1.69	1.81	—	9.88	15.00	9.50	324.0
72	P7220M230-N	N	18.046	17.876	18.898	AF-2	5.87	0.06	8.12	1.69	1.81	—	9.88	16.00	9.50	287.0
80	P8020M230-N	N	20.051	19.881	20.866	AF-2	5.87	0.06	8.12	1.69	1.81	—	9.88	18.00	9.50	280.0
90	P9020M230-N	N	22.558	22.388	23.425	AF-2	5.87	0.06	8.12	1.69	1.81	—	9.88	20.56	9.50	319.0
112	P11220M230-N	N	28.072	27.902	—	A-3	5.87	0.06	8.12	1.69	1.81	—	9.88	26.25	—	357.0
144	P14420M230-P	P	36.092	35.922	—	D-3	7.00	0.69	9.38	1.19	1.31	—	9.88	34.25	—	535.0
168	P16820M230-P	P	42.108	41.938	—	D-3	7.00	0.69	9.38	1.19	1.31	—	9.88	40.25	—	654.0
192	P19220M230-W	W	48.123	47.953	—	C-3	8.50	0.75	11.38	0.75	1.50	—	9.88	46.00	—	935.0
216	P21620M230-W	W	54.138	53.968	—	C-3	8.50	0.75	11.38	0.75	1.50	—	9.88	52.00	—	1062.0

* Weight Shown is for Sprocket less Bushing.
 • Reverse Mount Only

+ The numbers (1=Solid, 2=Web, 3=Arms), within the "Type" indicates construction and the letter F indicates the sprocket has flanges.

20mm | High Torque Sprockets

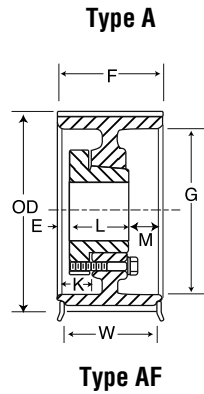

QD 290mm (11.42 in.) Wide Belts (20M-290)

No. of Teeth	Catalog Number	Bore	Pitch Diameter	Diameter (in.)		Type +	Max. Bore	Dimensions (in.)								Weight Approx. (lbs)	
				O.D.	Flange			E	L	M	H	K	F	G	W		
52	P5220M290-N	N	13.033	12.863	13.764	AF-1	5.87	0.75	8.12	2.38	2.50	—	12.25	10.88	11.88	187.0	
56	P5620M290-N	N	14.036	13.866	14.764	AF-1	5.87	0.75	8.12	2.38	2.50	—	12.25	11.88	11.88	223.0	
60	P6020M290-N	N	15.038	14.868	15.927	AF-1	5.87	0.75	8.12	2.38	2.50	—	12.25	13.06	11.88	257.0	
64	P6420M290-N	N	16.041	15.871	16.929	AF-1	5.87	0.75	8.12	2.38	2.50	—	12.25	14.06	11.88	299.0	
68	P6820M290-N	N	17.044	16.874	17.927	AF-1	5.87	0.75	8.12	2.38	2.50	—	12.25	15.00	11.88	346.0	
72	P7220M290-N	N	18.046	17.876	18.898	AF-2	5.87	0.75	8.12	2.38	2.50	—	12.25	16.00	11.88	311.0	
80	P8020M290-N	N	20.051	19.881	20.866	AF-2	5.87	0.75	8.12	2.38	2.50	—	12.25	18.00	11.88	314.0	
90	P9020M290-N	N	22.558	22.388	23.425	AF-2	5.87	0.75	8.12	2.38	2.50	—	12.25	20.56	11.88	359.0	
112	P11220M290-P	P	28.072	27.902	—	A-2	7.00	0.50	9.38	2.38	2.50	—	12.25	26.12	—	513.0	
144	P14420M290-P	P	36.092	35.922	—	A-3	7.00	0.50	9.38	2.38	2.50	—	12.25	34.00	—	637.0	
168	P16820M290-W	W	42.108	41.938	—	A-3	8.50	0.44	11.38	0.44	2.68	—	12.25	40.00	—	891.0	
192	P19220M290-W	W	48.123	47.953	—	A-3	8.50	0.44	11.38	0.44	2.68	—	12.25	46.00	—	1061.0	
216	P21620M290-W	W	54.138	53.968	—	A-3	8.50	0.44	11.38	0.44	2.68	—	12.25	52.00	—	1239.0	
QD 340 mm (13.39 in.) Wide Belts (20M-340)																	
52	P5220M340-N	N	13.033	12.863	13.764	AF-1	5.87	0.75	8.12	5.38	2.50	—	14.25	10.88	13.88	201.0	
56	P5620M340-N	N	14.036	13.866	14.764	AF-1	5.87	0.75	8.12	5.38	2.50	—	14.25	11.88	13.88	239.0	
60	P6020M340-N	N	15.038	14.868	15.927	AF-1	5.87	0.75	8.12	5.38	2.50	—	14.25	13.06	13.88	273.0	
64	P6420M340-N	N	16.041	15.871	16.929	AF-1	5.87	0.75	8.12	5.38	2.50	—	14.25	14.06	13.88	316.0	
68	P6820M340-N	N	17.044	16.874	17.927	AF-1	5.87	0.75	8.12	5.38	2.50	—	14.25	15.00	13.88	364.0	
72	P7220M340-N	N	18.046	17.876	18.898	AF-2	5.87	0.75	8.12	5.38	2.50	—	14.25	16.00	13.88	330.0	
80	P8020M340-P	P	20.051	19.881	20.866	AF-2	7.00	1.50	9.38	3.38	3.50	—	14.25	18.00	13.88	406.0	
90	P9020M340-P	P	22.558	22.388	23.425	AF-2	7.00	1.50	9.38	3.38	3.50	—	14.25	20.56	13.88	426.0	
112	P11220M340-P	P	28.072	27.902	—	A-2	7.00	1.50	9.38	3.38	3.50	—	14.25	26.12	—	543.0	
144	P14420M340-W	W	36.092	35.922	—	A-3	8.50	0.38	11.38	2.50	2.63	—	14.25	34.00	—	814.0	
168	P16820M340-W	W	42.108	41.938	—	A-3	8.50	0.38	11.38	2.50	2.63	—	14.25	40.00	—	947.0	
192	P19220M340-S	S	48.123	47.953	—	D-3	10.00	2.50	15.75	1.00	1.12	—	14.25	46.00	—	1368.0	
216	P21620M340-S	S	54.138	53.968	—	D-3	10.00	2.50	15.75	1.00	1.12	—	14.25	51.88	—	1555.0	

* Weight Shown is for Sprocket less Bushing.
• Reverse Mount Only

+ The numbers (1=Solid, 2=Web, 3=Arms), within the "Type" indicates construction and the letter F indicates the sprocket has flanges.

High HP HTS Synchronous Sprockets



“W” High HP HTS Sprockets (RPP® Tooth Profile) – Run with Hawk Pd®, Panther®, QT Power Chain® belts.

Martin’s High HP HTS Sprockets are designed to run with today’s highest horsepower RPP® profile belts.

“W” High HP HTS Sprockets are designed to run with latest design, higher horsepower belts.

High HP HTS Synchronous Sprockets allow you more flexibility in your selection criteria. The expanded line allows you to fit the application with the most cost effective sprockets.

W	24	8M	22	- JA
	Number of Teeth			Bushing or MPB
High HP HTS	Belt Pitch		Belt Width	
	8mm		12, 22, 35, 60	
	14mm		20, 42, 65, 90, 120	

- Available in 8mm and 14mm pitches
- Belt widths: 12mm, 22mm, 35mm, 60mm (8mm pitch)
20mm, 42mm, 65mm, 90mm, 120mm (14mm pitch)
- Available in QD, TB or MPB styles from stock.
- Typical Part Number: W248M22-JA

Hawk Pd® and Falcon Pd® are registered trademarks of Veyance Technologies, Inc. QT Power Chain® is a registered trademark of Altra Industrial Motion Corp. PolyChain® GT2® and HTS® are registered trademarks of Gates Corporation.

8mm | High HP HTS® Sprockets

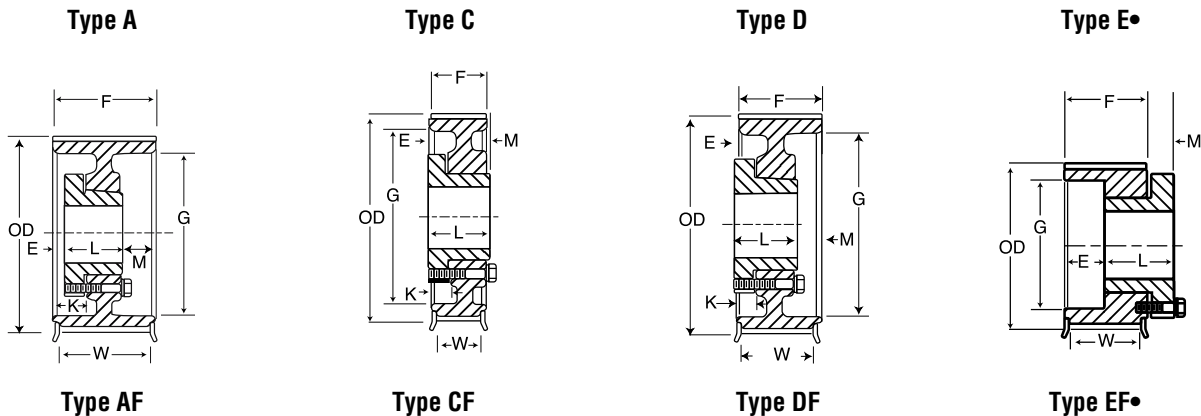

8mm Pitch, 12 mm (.47 in.) Wide Belts (8M-12)

No. of Teeth	Catalog Number	Bore	Pitch Diameter	Diameter (in.)		Type +	Max. Bore	Dimensions (in.)							Weight* Approx. (lbs)	
				O.D.	Flange			E	L	M	K	H	F	G		W
22	W228M12-MPB	MPB	2.206	2.154	2.562	MPB	1.188	0.623	1.452	1.620	0.827	...	0.577	1.0
24	W248M12-JA	JA	2.406	2.354	2.750	EF-1•	1.250	0.265	1.063	0.500	0.000	...	0.827	1.340	0.577	0.5
26	W268M12-JA	JA	2.607	2.554	2.937	EF-1•	1.250	0.265	1.063	0.500	0.000	...	0.827	1.340	0.577	0.6
28	W288M12-H	H	2.807	2.755	3.156	EF-1•	1.500	-0.048	1.250	0.375	0.000	...	0.827	1.570	0.577	0.7
30	W308M12-H	H	3.008	2.955	3.344	EF-1•	1.500	-0.048	1.250	0.375	0.000	...	0.827	1.570	0.577	0.9
32	W328M12-H	H	3.208	3.155	3.562	EF-1•	1.500	-0.048	1.250	0.375	0.000	...	0.827	1.570	0.577	1.1
34	W348M12-SH	SH	3.409	3.355	3.750	DF-1	1.688	0.500	1.313	0.014	0.000	...	0.827	2.750	0.577	1.1
36	W368M12-SH	SH	3.609	3.556	3.937	DF-1	1.688	0.500	1.313	0.014	0.000	...	0.827	2.820	0.577	1.3
38	W388M12-SH	SH	3.810	3.756	4.156	DF-1	1.688	0.500	1.313	0.014	0.000	...	0.827	3.000	0.577	1.6
40	W408M12-SH	SH	4.010	3.956	4.344	DF-1	1.688	0.500	1.313	0.014	0.000	...	0.827	3.000	0.577	1.9
44	W448M12-SDS	SDS	4.411	4.357	4.750	CF-1	2.000	0.548	1.375	0.000	0.077	...	0.827	3.500	0.577	2.1
48	W488M12-SDS	SDS	4.812	4.757	5.157	CF-1	2.000	0.548	1.375	0.000	0.077	...	0.827	3.800	0.577	2.7
56	W568M12-SDS	SDS	5.614	5.558	5.937	CF-1	2.000	0.548	1.375	0.000	0.077	...	0.827	4.600	0.577	4.0
64	W648M12-SDS	SDS	6.416	6.359	6.750	CF-1	2.000	0.548	1.375	0.000	0.077	...	0.827	5.400	0.577	5.5
72	W728M12-SDS	SDS	7.218	7.160	7.562	CF-1	2.000	0.548	1.375	0.000	0.077	...	0.827	6.200	0.577	7.3
80	W808M12-SDS	SDS	8.020	7.961	8.375	CF-2	2.000	0.548	1.375	0.000	0.077	...	0.827	6.900	0.577	9.2
90	W908M12-SDS	SDS	9.023	8.963	...	C-2	2.000	0.548	1.375	0.000	0.077	...	0.827	7.625	...	9.5
112	W1128M12-SK	SK	11.229	11.166	...	C-3	2.625	0.688	1.938	0.423	0.000	...	0.827	9.875	...	13.3
144	W1448M12-SK	SK	14.447	14.370	...	C-3	2.625	0.688	1.938	0.423	0.000	...	0.827	12.875	...	19.1
192	W1928M12-SF	SF	19.249	19.176	...	C-3	2.938	0.813	2.063	0.423	0.000	...	0.827	17.625	...	23.0

8mm Pitch, 22 mm (.86 in.) Wide Belts (8M-22)

22	W228M22-MPB	MPB	2.206	2.154	2.562	MPBF-1	1.188	0.619	1.840	0.000	...	1.625	1.22	...	0.97	1.3
24	W248M22-JA	JA	2.406	2.354	2.750	EF-1•	1.250	0.658	1.063	0.500	0.000	...	1.22	1.34	0.97	0.7
26	W268M22-JA	JA	2.607	2.554	2.937	EF-1•	1.250	0.658	1.063	0.500	0.000	...	1.22	1.34	0.97	1.0
28	W288M22-H	H	2.807	2.755	3.156	EF-1•	1.500	0.345	1.250	0.375	0.000	...	1.22	1.57	0.97	1.1
30	W308M22-H	H	3.008	2.955	3.344	EF-1•	1.500	0.345	1.250	0.375	0.000	...	1.22	1.57	0.97	1.3
32	W328M22-H	H	3.208	3.155	3.562	CF-1•	1.500	0.030	1.250	0.000	0.345	...	1.22	1.57	0.97	1.7
34	W348M22-SH	SH	3.409	3.355	3.750	DF-1	1.688	0.092	1.313	0.000	0.408	...	1.22	2.75	0.97	1.3
36	W368M22-SH	SH	3.609	3.556	3.937	DF-1	1.688	0.092	1.313	0.000	0.408	...	1.22	2.82	0.97	1.6
38	W388M22-SH	SH	3.810	3.756	4.156	DF-1	1.688	0.092	1.313	0.000	0.408	...	1.22	3.00	0.97	1.9
40	W408M22-SH	SH	4.010	3.956	4.344	DF-1	1.688	0.092	1.313	0.000	0.408	...	1.22	3.00	0.97	2.3
44	W448M22-SDS	SDS	4.411	4.357	4.750	DF-1	2.000	0.155	1.375	0.000	0.470	...	1.22	3.50	0.97	2.5
48	W488M22-SDS	SDS	4.812	4.757	5.157	DF-1	2.000	0.155	1.375	0.000	0.470	...	1.22	3.80	0.97	3.2
56	W568M22-SDS	SDS	5.614	5.558	5.937	DF-1	2.000	0.155	1.375	0.000	0.470	...	1.22	4.60	0.97	4.6
64	W648M22-SK	SK	6.416	6.359	6.750	DF-1	2.625	0.438	1.938	-0.280	0.250	...	1.22	5.40	0.97	7.7
72	W728M22-SK	SK	7.218	7.160	7.562	DF-1	2.625	0.438	1.938	-0.280	0.250	...	1.22	6.20	0.97	9.1
80	W808M22-SK	SK	8.020	7.961	8.375	DF-2	2.625	0.438	1.938	-0.280	0.250	...	1.22	6.90	0.97	9.1
90	W908M22-SK	SK	9.023	8.963	...	D-2	2.625	0.438	1.938	-0.280	0.250	...	1.22	7.63	...	12.0
112	W1128M22-SK	SK	11.229	11.166	...	D-3	2.625	0.438	1.938	-0.280	0.250	...	1.22	9.88	...	15.3
144	W1448M22-SF	SF	14.447	14.370	...	D-3	2.938	0.563	2.063	-0.280	0.250	...	1.22	12.88	...	19.1
192	W1928M22-E	E	19.249	19.176	...	C-3	3.500	1.202	2.625	0.202	-0.202	...	1.22	17.63	...	38.4

* Weight Shown is for Sprocket Less Bushing.

• Reverse Mount Only

+ The numbers (1=Solid, 2=Web, 3=Arms) within the "Type" indicates construction, and the letter F indicates the sprocket has flanges.

High HP HTS® Sprockets | 8mm

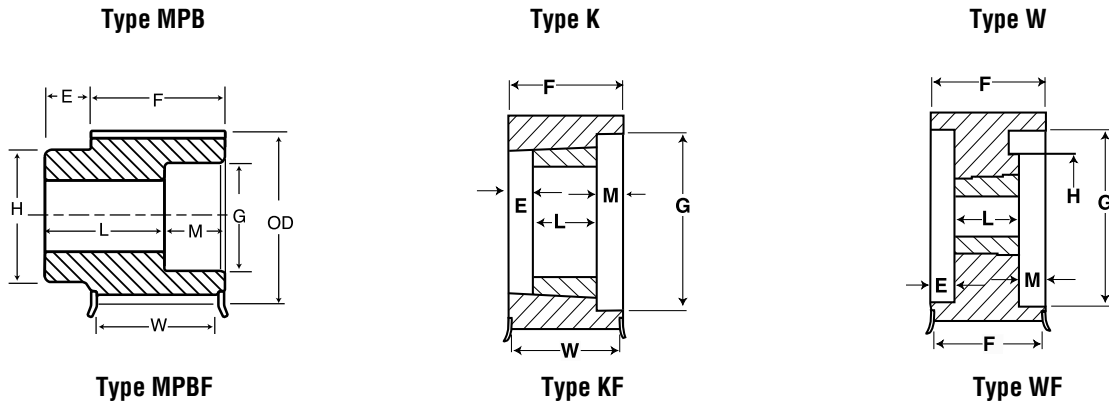

8mm Pitch, 35 mm (1.38in.) Wide Belts (8M - 35)

No. of Teeth	Catalog Number	Bore	Pitch Diameter	Diameter (in.)		Type +	Max. Bore	E	L	M	Dimensions (in.)					Weight* Approx. (lbs)
				O.D.	Flange						K	H	F	G	W	
22	W228M35-MPB	MPB	2.206	2.154	2.56	MBPF-1	1.188	0.618	2.3500	1.6250	1.73	...	1.428	1.6
24	W248M35-MPB	MPB	2.406	2.354	2.75	MBPF-1	1.250	0.618	2.3500	1.8125	1.73	...	1.428	2.0
26	W268M35-MPB	MPB	2.607	2.554	2.94	MBPF-1	1.375	0.618	2.3500	2.0000	1.73	...	1.428	2.4
28	W288M35-H	H	2.807	2.755	3.16	EF-1 •	1.500	0.855	1.2500	0.375	0.000	...	1.73	1.570	1.428	1.5
30	W308M35-H	H	3.008	2.955	3.34	EF-1 •	1.500	0.855	1.2500	0.375	0.000	...	1.73	1.570	1.428	1.9
32	W328M35-H	H	3.208	3.155	3.56	AF-1 •	1.500	0.245	1.2500	0.235	0.620	...	1.73	1.570	1.428	2.4
34	W348M35-SH	SH	3.409	3.355	3.75	AF-1	1.688	0.120	1.3125	0.298	0.620	...	1.73	2.750	1.428	2.4
36	W368M35-SH	SH	3.609	3.556	3.94	AF-1	1.688	0.120	1.3125	0.298	0.620	...	1.73	2.820	1.428	2.8
38	W388M35-SH	SH	3.810	3.756	4.16	AF-1	1.688	0.120	1.3125	0.298	0.620	...	1.73	3.000	1.428	3.0
40	W408M35-SH	SH	4.010	3.956	4.34	AF-1	1.688	0.120	1.3125	0.298	0.620	...	1.73	3.000	1.428	2.8
44	W448M35-SD	SD	4.411	4.357	4.75	DF-1	2.000	0.313	1.8125	0.232	0.250	...	1.73	3.500	1.428	3.1
48	W488M35-SD	SD	4.812	4.757	5.16	DF-1	2.000	0.313	1.8125	0.232	0.250	...	1.73	3.800	1.428	3.5
56	W568M35-SK	SK	5.614	5.558	5.94	DF-1	2.625	0.438	1.9375	0.230	0.250	...	1.73	4.600	1.428	5.3
64	W648M35-SK	SK	6.416	6.359	6.75	DF-1	2.625	0.438	1.9375	0.230	0.250	...	1.73	5.400	1.428	8.4
72	W728M35-SK	SK	7.218	7.160	7.56	DF-1	2.625	0.438	1.9375	0.230	0.250	...	1.73	6.200	1.428	9.1
80	W808M35-SF	SF	8.020	7.961	8.38	DF-1	2.938	0.563	2.0625	0.230	0.250	...	1.73	6.900	1.428	15.1
90	W908M35-SF	SF	9.023	8.963	...	D-2	2.938	0.563	2.0625	0.230	0.250	...	1.73	7.625	...	20.7
112	W1128M35-SF	SF	11.229	11.166	...	A-3	2.938	0.563	2.0625	0.230	0.250	...	1.73	9.875	...	18.0
144	W1448M35-E	E	14.447	14.370	...	C-3	3.500	0.893	2.6250	0.000	0.107	...	1.73	12.875	...	38.0
192	W1928M35-E	E	19.249	19.176	...	C-3	3.500	0.893	2.6250	0.000	0.107	...	1.73	17.625	...	53.0

8mm Pitch, 60 mm (2.36 in.) Wide Belts (8M-60)

22	W228M60-MPB	MPB	2.206	2.154	2.562	MPBF-1	1.188	0.619	3.375	1.625	2.756	...	2.506	2.2
24	W248M60-MPB	MPB	2.406	2.354	2.750	MPBF-1	1.250	0.619	3.375	1.813	2.756	...	2.506	2.7
26	W268M60-MPB	MPB	2.607	2.554	2.937	MPBF-1	1.375	0.619	3.375	2.000	2.756	...	2.506	3.3
28	W288M60-MPB	MPB	2.807	2.755	3.156	MPBF-1	1.500	0.619	3.375	2.281	2.756	...	2.506	4.4
30	W308M60-MPB	MPB	3.008	2.955	3.344	MPBF-1	1.563	0.619	3.375	2.468	2.756	...	2.506	5.1
32	W328M60-MPB	MPB	3.208	3.155	3.562	MPBF-1	1.625	0.619	3.375	2.593	2.756	...	2.506	5.9
34	W348M60-MPB	MPB	3.409	3.355	3.750	MPBF-1	1.688	0.619	3.375	2.796	2.756	...	2.506	6.6
36	W368M60-MPB	MPB	3.609	3.556	3.937	MPBF-1	1.750	0.619	3.375	3.000	2.756	...	2.506	7.8
36	W368M60-2012	2012*	3.609	3.556	3.937	KF-1	2.000	1.506	1.250	0.000	2.756	2.820	2.506	2.3
38	W388M60-MPB	MPB	3.810	3.756	4.156	MPBF-1	1.938	0.619	3.375	3.188	2.756	...	2.506	8.8
38	W388M60-2012	2012*	3.810	3.756	4.156	KF-1	2.000	1.506	1.250	0.000	2.756	3.000	2.506	2.8
40	W408M60-MPB	MPB	4.010	3.956	4.344	MPBF-1	2.125	0.619	3.375	3.813	2.756	...	2.506	9.8
40	W408M60-2012	2012*	4.010	3.956	4.344	WF-1	2.000	1.506	1.250	0.000	2.756	3.000	2.506	2.3
44	W448M60-2517	2517	4.411	4.357	4.750	WF-1	2.500	0.503	1.750	0.503	2.756	3.500	2.506	5.4
48	W488M60-2517	2517	4.812	4.757	5.157	WF-1	2.500	0.503	1.750	0.503	2.756	3.800	2.506	3.2
56	W568M60-3020	3020	5.614	5.558	5.937	WF-1	3.000	0.378	2.000	0.378	2.756	4.600	2.506	6.3
64	W648M60-SF	SF	6.416	6.359	6.750	AF-1	2.938	-0.061	2.063	0.754	0.752	...	2.756	5.400	2.506	9.8
72	W728M60-E	E	7.218	7.160	7.562	AF-1	3.500	0.000	2.625	0.131	1.000	...	2.756	6.200	2.506	12.8
80	W808M60-E	E	8.020	7.961	8.375	AF-1	3.500	0.000	2.625	0.131	1.000	...	2.756	6.900	2.506	19.3
90	W908M60-E	E	9.023	8.963	...	A-1	3.500	0.000	2.625	0.131	1.000	...	2.756	7.625	...	20.7
112	W1128M60-F	F	11.229	11.166	...	C-3	4.000	0.869	3.625	0.000	0.256	...	2.756	9.875	...	50.3
144	W1448M60-F	F	14.447	14.370	...	C-3	4.000	0.869	3.625	0.000	0.256	...	2.756	12.875	...	73.2
192	W1928M60-F	F	19.249	19.176	...	C-3	4.000	0.869	3.625	0.000	0.256	...	2.756	17.625	...	81.3

+ The numbers (1=Solid, 2=Web, 3=Arms) within the "Type" indicates construction, and the letter F indicates the sprocket has flanges.

* Weight Shown is for Sprocket Less Bushing.
• Reverse Mount Only

14mm | High HP HTS® Sprockets

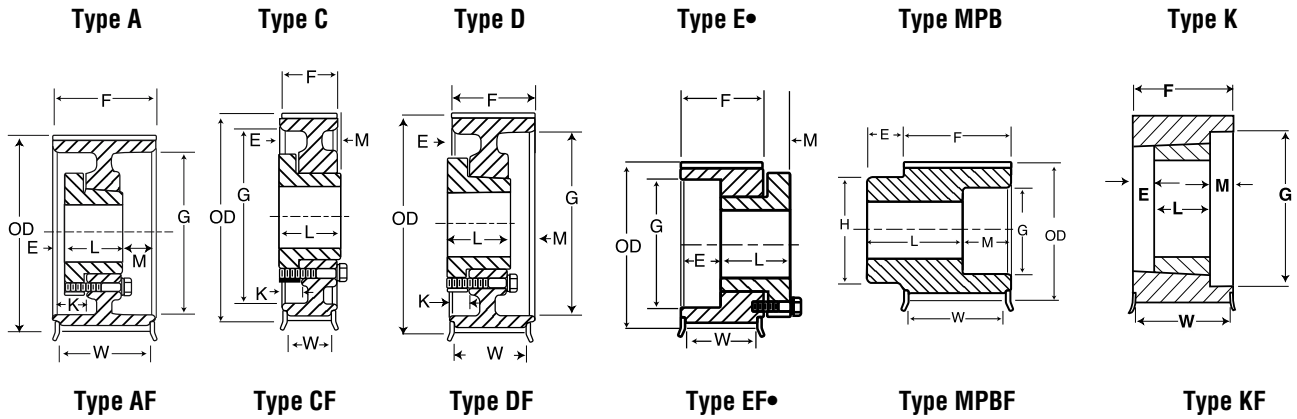

14mm Pitch, 20 mm (.79in.) Wide Belts (14M - 20)																
No. of Teeth	Catalog Number	Bore	Pitch Diameter	Diameter (in.)		Type +	Max. Bore	Dimensions (in.)								Weight* Approx. (lbs)
				O.D.	Flange			E	L	M	K	H	F	G	W	
28	W2814M20-SK	SK	4.912	4.805	5.56	DF-1	2.625	0.688	1.938	-0.030	0.000	..	1.220	2.740	0.908	3.6
29	W2914M20-SK	SK	5.088	4.981	5.56	DF-1	2.625	0.688	1.938	-0.030	0.000	..	1.220	2.740	0.908	4.0
30	W3014M20-SK	SK	5.263	5.156	6.13	DF-1	2.625	0.688	1.938	-0.030	0.000	..	1.220	2.740	0.908	4.4
32	W3214M20-SK	SK	5.614	5.507	6.13	DF-1	2.625	0.688	1.938	-0.030	0.000	..	1.220	2.740	0.908	5.3
34	W3414M20-SK	SK	5.965	5.857	6.5	DF-1	2.625	0.688	1.938	-0.030	0.000	..	1.220	2.740	0.908	6.2
36	W3614M20-SF	SF	6.316	6.208	6.81	CF-1	2.938	0.813	2.063	-0.030	0.000	..	1.220	3.050	0.908	5.7
38	W3814M20-SF	SF	6.667	6.559	7.16	CF-1	2.938	0.813	2.063	-0.030	0.000	..	1.220	3.050	0.908	6.5
40	W4014M20-SF	SF	7.018	6.910	7.5	CF-1	2.938	0.813	2.063	-0.030	0.000	..	1.220	3.050	0.908	7.6
44	W4414M20-E	E	7.720	7.611	8.22	CF-1	3.500	1.000	2.625	0.405	0.000	..	1.220	...	0.908	10.2
48	W4814M20-E	E	8.421	8.312	8.94	CF-1	3.500	1.000	2.625	0.405	0.000	..	1.220	...	0.908	13.0
52	W5214M20-E	E	9.123	9.014	9.69	CF-1	3.500	1.000	2.625	0.405	0.000	..	1.220	...	0.908	16.7
56	W5614M20-E	E	9.825	9.715	10.38	CF-1	3.500	1.000	2.625	0.405	0.000	..	1.220	...	0.908	20.4
60	W6014M20-E	E	10.527	10.417	11.06	CF-1	3.500	1.000	2.625	0.405	0.000	..	1.220	...	0.908	23.6
64	W6414M20-E	E	11.229	11.118	11.75	CF-1	3.500	1.000	2.625	0.405	0.000	..	1.220	...	0.908	27.1
68	W6814M20-E	E	11.930	11.820	12.5	CF-2	3.500	1.000	2.625	0.405	0.000	..	1.220	...	0.908	26.8
72	W7214M20-E	E	12.632	12.521	13.19	CF-2	3.500	1.000	2.625	0.405	0.000	..	1.220	...	0.908	29.6
80	W8014M20-E	E	14.036	13.924	14.63	CF-2	3.500	1.000	2.625	0.405	0.000	..	1.220	...	0.908	35.3
90	W9014M20-E	E	15.790	15.677	...	C-3	3.500	1.188	2.625	0.218	-0.188	..	1.220	13.563	...	36.6
112	W11214M20-E	E	19.650	19.535	...	C-3	3.500	1.188	2.625	0.218	-0.188	..	1.220	17.375	...	48.0
144	W14414M20-E	E	25.264	25.147	...	C-3	3.500	1.188	2.625	0.218	-0.188	..	1.220	23.000	...	59.4
168	W16814M20-F	F	29.475	29.355	...	C-3	4.000	1.563	3.625	0.842	-0.438	..	1.220	27.250	...	98.4
192	W19214M20-J	J	33.686	33.564	...	C-3	4.500	1.938	4.500	1.342	-0.626	..	1.220	31.375	...	147.4
216	W21614M20-J	J	37.896	37.772	...	C-3	4.500	1.938	4.500	1.342	-0.626	..	1.220	35.625	...	155.6
14mm Pitch, 42 mm (1.65 in.) Wide Belts (14M-42)																
28	W2814M42-SK	SK	4.912	4.805	5.56	EF-1 •	2.625	0.837	1.938	0.688	2.087	2.740	1.774	5.5
29	W2914M42-SK	SK	5.088	4.981	5.56	EF-1 •	2.625	0.837	1.938	0.688	2.087	2.740	1.774	6.2
30	W3014M42-SK	SK	5.263	5.156	6.13	DF-1	2.625	0.267	1.938	0.416	0.421	..	2.087	3.920	1.774	5.9
32	W3214M42-SK	SK	5.614	5.507	6.13	DF-1	2.625	0.267	1.938	0.416	0.42	..	2.087	3.920	1.774	7.4
34	W3414M42-SF	SF	5.965	5.857	6.50	DF-1	2.938	0.391	2.063	0.415	0.421	..	2.087	3.920	1.774	8.8
36	W3614M42-SF	SF	6.316	6.208	6.81	DF-1	2.938	0.391	2.063	0.415	0.421	..	2.087	4.688	1.774	7.8
38	W3814M42-SF	SF	6.667	6.559	7.16	DF-1	2.938	0.391	2.063	0.415	0.421	..	2.087	4.938	1.774	9.2
40	W4014M42-SF	SF	7.018	6.910	7.50	DF-1	2.938	0.391	2.063	0.415	0.421	..	2.087	5.063	1.774	10.8
44	W4414M42-E	E	7.720	7.611	8.22	DF-1	3.500	0.772	2.625	0.234	0.228	..	2.087	6.125	1.774	13.1
48	W4814M42-E	E	8.421	8.312	8.94	DF-1	3.500	0.772	2.625	0.234	0.228	..	2.087	6.500	1.774	17.2
52	W5214M42-E	E	9.123	9.014	9.69	DF-1	3.500	0.772	2.625	0.234	0.228	..	2.087	7.188	1.774	21.2
56	W5614M42-E	E	9.825	9.715	10.38	DF-1	3.500	0.772	2.625	0.234	0.228	..	2.087	7.875	1.774	25.6
60	W6014M42-E	E	10.527	10.417	11.06	DF-1	3.500	0.772	2.625	0.234	0.228	..	2.087	8.500	1.774	30.3
64	W6414M42-E	E	11.229	11.118	11.75	DF-1	3.500	0.772	2.625	0.234	0.228	..	2.087	9.250	1.774	35.1
68	W6814M42-E	E	11.930	11.820	12.50	DF-2	3.500	0.772	2.625	0.234	0.228	..	2.087	10.000	1.774	33.7
72	W7214M42-E	E	12.632	12.521	13.19	DF-2	3.500	0.772	2.625	0.234	0.228	..	2.087	10.688	1.774	37.3
80	W8014M42-E	E	14.036	13.924	14.63	DF-2	3.500	0.772	2.625	0.234	0.228	..	2.087	12.125	1.774	44.5
90	W9014M42-F	F	15.790	15.677	...	C-3	4.000	1.125	3.625	0.413	2.087	13.563	...	50.8
112	W11214M42-F	F	19.650	19.535	...	C-3	4.000	1.125	3.625	0.413	2.087	17.375	...	77.3
144	W14414M42-F	F	25.264	25.147	...	C-3	4.000	1.125	3.625	0.413	2.087	23.000	...	97.4
168	W16814M42-F	F	29.475	29.355	...	C-3	4.000	1.125	3.625	0.413	2.087	27.250	...	119.3
192	W19214M42-J	J	33.686	33.564	...	C-3	4.500	1.505	4.500	0.908	..	-0.192	2.087	31.375	...	173.5
216	W21614M42-J	J	37.896	37.772	...	C-3	4.500	1.505	4.500	0.908	..	-0.192	2.087	35.625	...	206.0

* Weight Shown is for Sprocket Less Bushing.
• Reverse Mount Only

+ The numbers (1=Solid, 2=Web, 3=Arms) within the "Type" indicates construction, and the letter F indicates the sprocket has flanges.

High HP HTS® Sprockets | 14mm

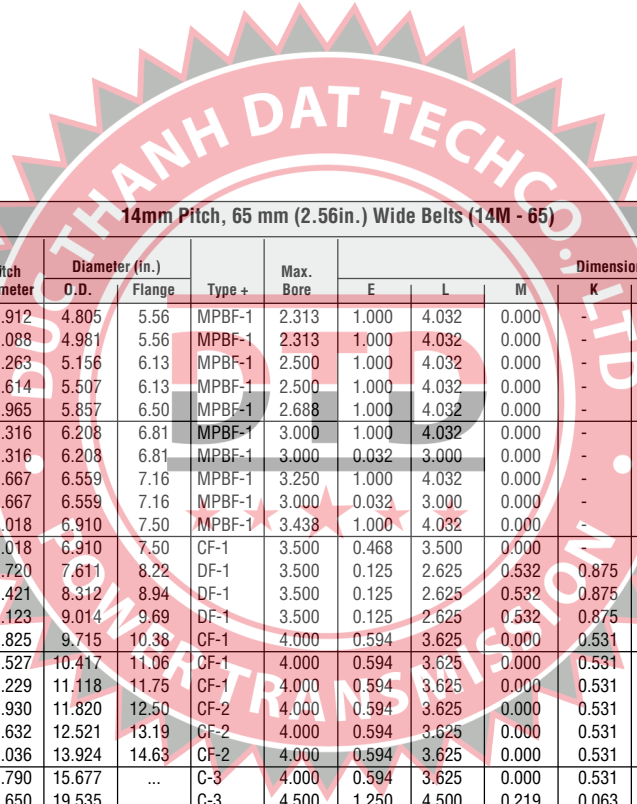
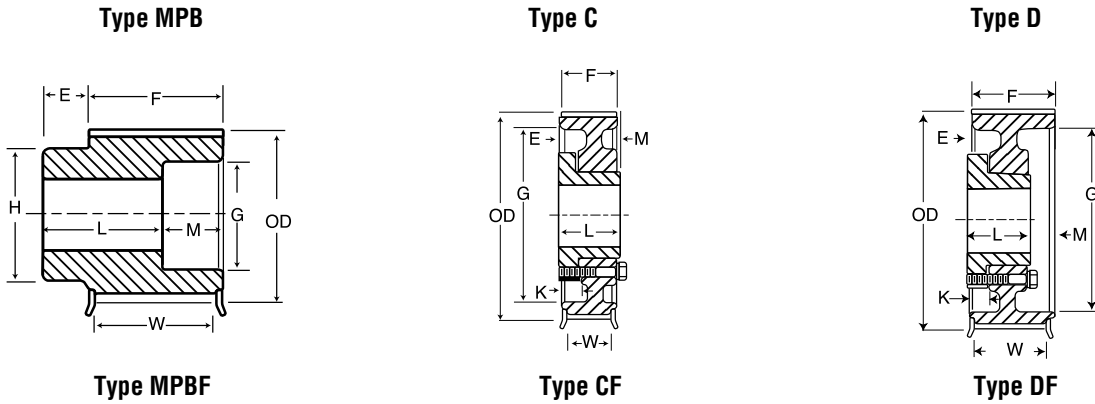

14mm Pitch, 65 mm (2.56in.) Wide Belts (14M - 65)																	
No. of Teeth	Catalog Number	Bore	Pitch Diameter	Diameter (in.)			Type +	Max. Bore	Dimensions (in.)								Weight* Approx. (lbs)
				O.D.	Flange				E	L	M	K	H	F	G	W	
28	W2814M65-MPB	MPB	4.912	4.805	5.56	MPBF-1	2.313	1.000	4.032	0.000	-	3.688	3.032	0.000	2.719	15.0	
29	W2914M65-MPB	MPB	5.088	4.981	5.56	MPBF-1	2.313	1.000	4.032	0.000	-	3.688	3.032	0.000	2.719	16.0	
30	W3014M65-MPB	MPB	5.263	5.156	6.13	MPBF-1	2.500	1.000	4.032	0.000	-	4.141	3.032	0.000	2.719	18.0	
32	W3214M65-MPB	MPB	5.614	5.507	6.13	MPBF-1	2.500	1.000	4.032	0.000	-	4.141	3.032	0.000	2.719	20.2	
34	W3414M65-MPB	MPB	5.965	5.857	6.50	MPBF-1	2.688	1.000	4.032	0.000	-	4.484	3.032	0.000	2.719	23.4	
36	W3614M65-MPB	MPB	6.316	6.208	6.81	MPBF-1	3.000	1.000	4.032	0.000	-	4.875	3.032	0.000	2.719	24.5	
36	W3614M65-3030	3030*	6.316	6.208	6.81	MPBF-1	3.000	0.032	3.000	0.000	-	0.000	3.032	0.000	2.719	10.8	
38	W3814M65-MPB	MPB	6.667	6.559	7.16	MPBF-1	3.250	1.000	4.032	0.000	-	5.172	3.032	0.000	2.719	27.6	
38	W3814M65-3030	3030*	6.667	6.559	7.16	MPBF-1	3.000	0.032	3.000	0.000	-	0.000	3.032	0.000	2.719	13.4	
40	W4014M65-MPB	MPB	7.018	6.910	7.50	MPBF-1	3.438	1.000	4.032	0.000	-	5.563	3.032	0.000	2.719	31.5	
40	W4014M65-3535	3535*	7.018	6.910	7.50	CF-1	3.500	0.468	3.500	0.000	-	6.125	3.032	3.875	2.719	13.2	
44	W4414M65-E	E	7.720	7.611	8.22	DF-1	3.500	0.125	2.625	0.532	0.875	...	3.032	6.125	2.719	16.2	
48	W4814M65-E	E	8.421	8.312	8.94	DF-1	3.500	0.125	2.625	0.532	0.875	...	3.032	6.500	2.719	21.4	
52	W5214M65-E	E	9.123	9.014	9.69	DF-1	3.500	0.125	2.625	0.532	0.875	...	3.032	7.188	2.719	25.9	
56	W5614M65-F	F	9.825	9.715	10.38	CF-1	4.000	0.594	3.625	0.000	0.531	...	3.032	7.875	2.719	36.3	
60	W6014M65-F	F	10.527	10.417	11.06	CF-1	4.000	0.594	3.625	0.000	0.531	...	3.032	8.500	2.719	43.5	
64	W6414M65-F	F	11.229	11.118	11.75	CF-1	4.000	0.594	3.625	0.000	0.531	...	3.032	9.250	2.719	51.0	
68	W6814M65-F	F	11.930	11.820	12.50	CF-2	4.000	0.594	3.625	0.000	0.531	7.750	3.032	10.000	2.719	47.9	
72	W7214M65-F	F	12.632	12.521	13.19	CF-2	4.000	0.594	3.625	0.000	0.531	7.750	3.032	10.688	2.719	52.7	
80	W8014M65-F	F	14.036	13.924	14.63	CF-2	4.000	0.594	3.625	0.000	0.531	7.750	3.032	12.125	2.719	61.2	
90	W9014M65-F	F	15.790	15.677	...	C-3	4.000	0.594	3.625	0.000	0.531	7.750	3.032	13.563	...	59.8	
112	W11214M65-J	J	19.650	19.535	...	C-3	4.500	1.250	4.500	0.219	0.063	9.000	3.032	17.375	...	104.2	
144	W14414M65-M	M	25.264	25.147	...	C-3	5.500	2.063	6.750	1.657	-0.500	11.375	3.032	23.000	...	197.3	
168	W16814M65-M	M	29.475	29.355	...	C-3	5.500	2.063	6.750	1.657	-0.500	11.375	3.032	27.250	...	207.0	
192	W19214M65-M	M	33.686	33.564	...	C-3	5.500	2.063	6.750	1.657	-0.500	11.375	3.032	31.375	...	173.5	
216	W21614M65-M	M	37.896	37.772	...	C-3	5.500	2.063	6.750	1.657	-0.500	11.375	3.032	35.625	...	253.0	

+ The numbers (1=Solid, 2=Web, 3=Arms) within the "Type" indicates construction, and the letter F indicates the sprocket has flanges.

* Weight Shown is for Sprocket Less Bushing.
• Reverse Mount Only

14mm | High HP HTS® Sprockets

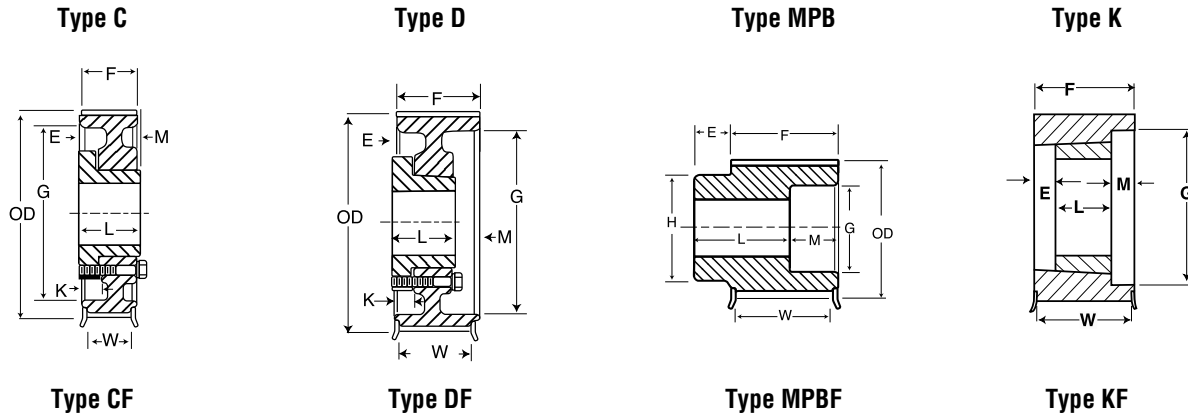

14mm Pitch, 90 mm (3.54 in.) Wide Belts (14M-90)

No. of Teeth	Catalog Number	Bore	Pitch Diameter	Diameter (in.)			Type +	Max. Bore	Dimensions (in.)							Weight* Approx. (lbs)
				O.D.	Flange	E			L	M	K	H	F	G	W	
28	W2814M90-MPB	MPB	4.912	4.805	5.56	MPBF-1	2.313	1.000	5.055	3.688	4.055	0.000	3.743	18.9
29	W2914M90-MPB	MPB	5.088	4.981	5.56	MPBF-1	2.313	1.000	5.055	3.688	4.055	0.000	3.743	20.2
30	W3014M90-MPB	MPB	5.263	5.156	6.13	MPBF-1	2.500	1.000	5.055	4.141	4.055	0.000	3.743	10.9
32	W3214M90-MPB	MPB	5.614	5.507	6.13	MPBF-1	2.500	1.000	5.055	4.141	4.055	0.000	3.743	13.9
34	W3414M90-MPB	MPB	5.965	5.857	6.50	MPBF-1	2.688	1.000	5.055	4.484	4.055	0.000	3.743	16.7
36	W3614M90-MPB	MPB	6.316	6.208	6.81	MPBF-1	3.000	1.000	5.055	4.875	4.055	0.000	3.743	31.4
38	W3814M90-MPB	MPB	6.667	6.559	7.16	MPBF-1	3.250	1.000	5.055	5.172	4.055	4.938	3.743	35.5
40	W4014M90-3535	3535	7.018	6.910	7.50	KF-1	3.500	0.555	3.500	0.000	4.055	...	3.743	17.1
44	W4414M90-3535	3535	7.720	7.611	8.22	KF-1	4.000	0.555	3.500	0.000	4.055	...	3.743	24.8
48	W4814M90-4040	4040	8.421	8.312	8.94	KF-1	4.000	0.055	4.000	0.000	4.055	...	3.743	27.0
52	W5214M90-F	F	9.123	9.014	9.69	DF-1	4.000	0.347	3.625	0.778	0.778	...	4.055	7.188	3.743	34.7
56	W5614M90-F	F	9.825	9.715	10.38	DF-1	4.000	0.347	3.625	0.778	0.778	...	4.055	7.875	3.743	36.3
60	W6014M90-F	F	10.527	10.417	11.06	DF-1	4.000	0.347	3.625	0.778	0.778	...	4.055	8.500	3.743	49.8
64	W6414M90-F	F	11.229	11.118	11.75	DF-1	4.000	0.347	3.625	0.778	0.778	...	4.055	9.250	3.743	57.6
68	W6814M90-F	F	11.930	11.820	12.50	DF-2	4.000	0.347	3.625	0.778	0.778	...	4.055	10.000	3.743	54.8
72	W7214M90-F	F	12.632	12.521	13.19	DF-2	4.000	0.347	3.625	0.778	0.778	...	4.055	10.688	3.743	60.0
80	W8014M90-J	J	14.036	13.924	14.63	CF-2	4.500	0.375	4.500	0.070	0.938	...	4.055	12.125	3.743	81.5
90	W9014M90-J	J	15.790	15.677	...	C-3	4.500	0.375	4.500	0.070	0.938	...	4.055	13.563	...	77.4
112	W11214M90-J	J	19.650	19.535	...	C-3	4.500	0.375	4.500	0.070	0.938	...	4.055	17.375	...	116.2
144	W14414M90-M	M	25.264	25.147	...	C-3	5.500	1.563	6.750	1.132	0.000	11.375	4.055	23.000	...	220.0
168	W16814M90-M	M	29.475	29.355	...	C-3	5.500	1.563	6.750	1.132	0.000	11.375	4.055	27.250	...	207.0
192	W19214M90-M	M	33.686	33.564	...	C-3	5.500	1.563	6.750	1.132	0.000	11.375	4.055	31.375	...	268.4
216	W21614M90-M	M	37.896	37.772	...	C-3	5.500	1.563	6.750	1.132	0.000	11.375	4.055	35.625	...	278.1

+ The numbers (1=Solid, 2=Web, 3=Arms) within the "Type" indicates construction, and the letter F indicates the sprocket has flanges.

* Weight Shown is for Sprocket Less Bushing.
• Reverse Mount Only

High HP HTS® Sprockets | 14mm

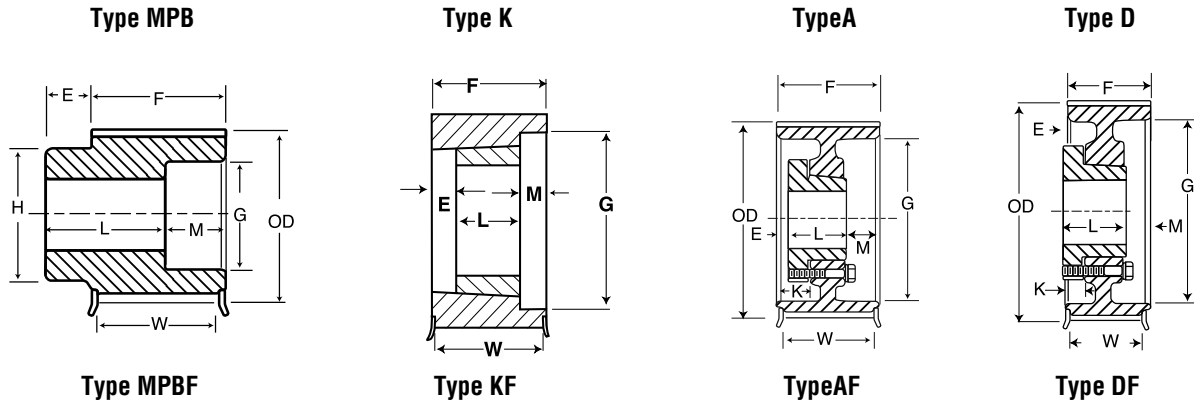

14mm Pitch, 120 mm (4.72 in.) Wide Belts (14M-120)

No. of Teeth	Catalog Number	Bore	Pitch Diameter	Diameter (in.)		Type +	Max. Bore	Dimensions (in.)							Weight* Approx. (lbs)	
				O.D.	Flange			E	L	M	K	H	F	G		W
28	W2814M120-MPB	MPB	4.912	4.805	5.56	MPBF-1	2.313	1.000	4.986	1.250	...	3.688	5.236	3.125	4.924	22.0
29	W2914M120-MPB	MPB	5.088	4.981	5.56	MPBF-1	2.313	1.000	4.986	1.250	...	3.688	5.236	3.125	4.924	23.8
30	W3014M120-MPB	MPB	5.263	5.156	6.13	MPBF-1	2.500	1.000	4.986	1.250	...	4.141	5.236	3.906	4.924	25.1
32	W3214M120-MPB	MPB	5.614	5.507	6.13	MPBF-1	2.500	1.000	4.986	1.250	...	4.141	5.236	3.906	4.924	29.0
34	W3414M120-MPB	MPB	5.965	5.857	6.50	MPBF-1	2.688	1.000	4.986	1.250	...	4.484	5.236	4.063	4.924	33.7
36	W3614M120-MPB	MPB	6.316	6.208	6.81	MPBF-1	3.000	1.000	4.986	1.250	...	4.875	5.236	4.688	4.924	34.0
38	W3814M120-MPB	MPB	6.667	6.559	7.16	MPBF-1	3.250	1.000	4.986	1.250	...	5.172	5.236	4.938	4.924	38.4
40	W4014M120-MPB	MPB	7.018	6.910	7.50	MPBF-1	3.438	1.000	4.986	1.250	...	5.563	5.236	5.063	4.924	43.4
44	W4414M120-3535	3535	7.720	7.611	8.22	KF-1	4.000	0.868	3.500	0.868	5.236	5.875	4.924	24.8
48	W4814M120-4040	4040	8.421	8.312	8.94	KF-1	4.000	0.618	4.000	0.618	5.236	6.625	4.924	31.8
52	W5214M120-F	F	9.123	9.014	9.69	AF-1	4.000	1.125	3.625	1.361	1.375	...	5.236	7.188	4.924	34.7
56	W5614M120-F	F	9.825	9.715	10.38	AF-1	4.000	1.125	3.625	1.361	1.375	...	5.236	7.875	4.924	48.4
60	W6014M120-F	F	10.527	10.417	11.06	AF-1	4.000	1.125	3.625	1.361	1.375	...	5.236	8.500	4.924	57.1
64	W6414M120-J	J	11.229	11.118	11.75	DF-1	4.500	0.293	4.500	1.029	1.029	...	5.236	9.250	4.924	69.7
68	W6814M120-J	J	11.930	11.820	12.50	DF-1	4.500	0.293	4.500	1.029	1.029	...	5.236	10.000	4.924	80.4
72	W7214M120-J	J	12.632	12.521	13.19	DF-1	4.500	0.293	4.500	1.029	1.029	...	5.236	10.688	4.924	92.2
80	W8014M120-J	J	14.036	13.924	14.63	DF-2	4.500	0.293	4.500	1.029	1.029	...	5.236	12.125	4.924	92.5
90	W9014M120-M	M	15.790	15.677	...	C-2	5.500	1.514	6.750	0.000	0.049	10.000	5.236	13.563	...	134.5
112	W11214M120-M	M	19.650	19.535	...	C-3	5.500	1.514	6.750	0.000	0.049	11.375	5.236	17.375	...	193.4
144	W14414M120-M	M	25.264	25.147	...	C-3	5.500	1.514	6.750	0.000	0.049	11.375	5.236	23.000	...	234.6
168	W16814M120-M	M	29.475	29.355	...	C-3	5.500	1.514	6.750	0.000	0.049	11.375	5.236	27.250	...	245.8
192	W19214M120-N	N	33.686	33.564	...	C-3	6.000	1.875	8.125	1.014	0.000	12.000	5.236	31.375	...	381.5

+ The numbers (1=Solid, 2=Web, 3=Arms) within the "Type" indicates construction, and the letter F indicates the sprocket has flanges.

* Weight Shown is for Sprocket Less Bushing.
• Reverse Mount Only

MPC® Sprockets



For use with:

PANTHER XT

MPC® Synchronous Sprockets

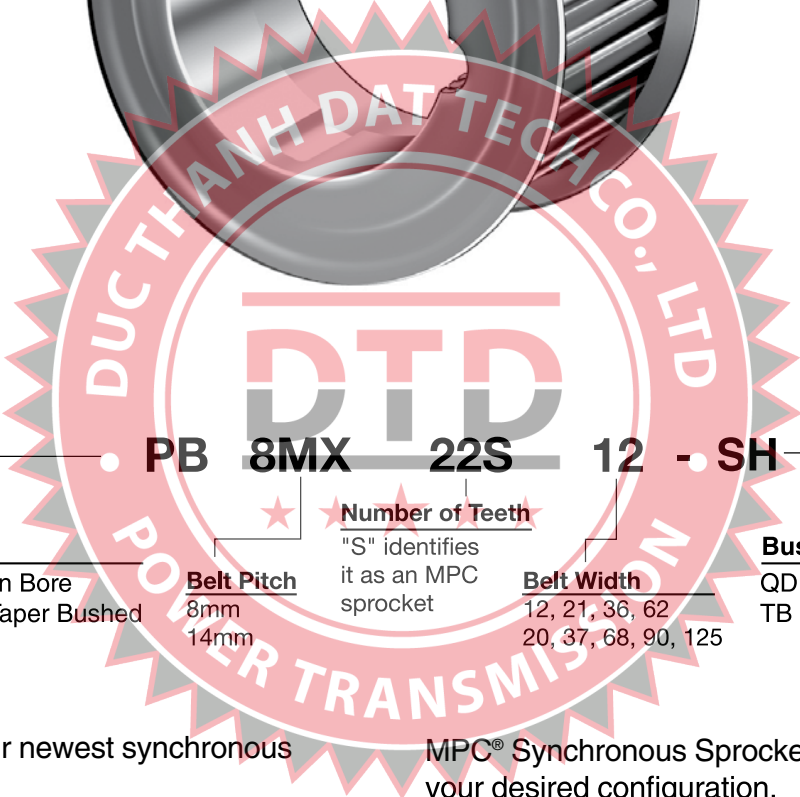

<p>Bore Style</p> <p>PB - Minimum Plain Bore No prefix - QD or Taper Bushed</p>	<p>Belt Pitch</p> <p>8mm 14mm</p>	<p>Number of Teeth</p> <p>"S" identifies it as an MPC sprocket</p>	<p>Belt Width</p> <p>12, 21, 36, 62 20, 37, 68, 90, 125</p>	<p>Bushing Options</p> <p>QD - JA, SH, SDS...S TB - 1008, 1108...120100</p>
--	--	---	--	--

Introducing our newest synchronous sprocket.
The addition of our MPC sprocket line makes *Martin* your one-stop-shop for all your synchronous sprocket needs. Match your sprocket to your favorite belt.

MPC® Synchronous Sprockets are available in your desired configuration.

- Available in 8mm and 14mm pitches.
- Belt widths:
12mm, 21mm, 36mm, 62mm (8mm pitch)
20mm, 37mm, 68mm, 90mm, 125mm (14mm pitch)
- Available in QD, TB or other special adapters.
- Special diameters and widths, as well as special materials, are also available.

8mm | MPC® Sprockets

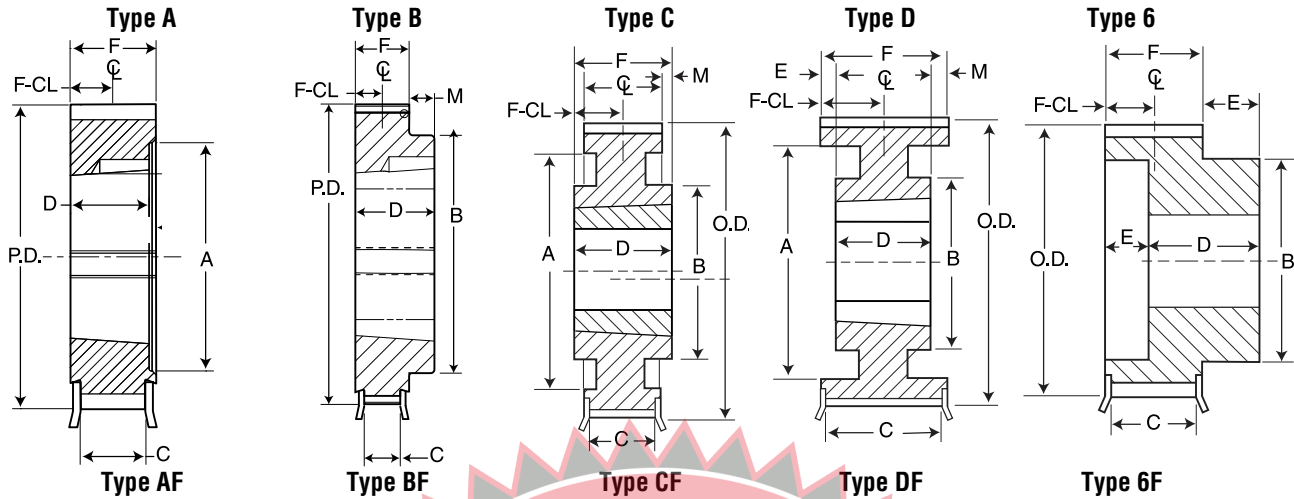

8mm Pitch — 12mm Wide Belt

No. of Teeth	Catalog Number	Bore	Pitch Diameter	Diameter (in.)		Type	Max. Bore	Dimensions (in.)							Weight Approx. (lbs.)	
				O.D.	Max. Flange O.D.			A	B	C	D	E	F	M		F-CL
MBP 8mm Pitch, 12mm (0.47 in.) Wide Belts (8M-12)																
22	PB8MX22S12	1/2	2.206	2.143	2.610	6F-1	1.188		1.79	0.57	1.31	0.46	0.82		0.41	1.1
25	PB8MX25S12	1/2	2.506	2.443	2.910	6F-1	1.500		2.08	0.57	1.31	0.46	0.82		0.41	1.5
28	PB8MX28S12	1/2	2.807	2.744	3.210	6F-1	1.750		2.34	0.57	1.31	0.46	0.82		0.41	1.9
30	PB8MX30S12	1/2	3.008	2.945	3.410	6F-1	1.813		2.54	0.57	1.42	0.57	0.82		0.41	2.3
32	PB8MX32S12	1/2	3.208	3.145	3.610	6F-1	2.000		2.73	0.57	1.42	0.57	0.82		0.41	2.7
Taper Bushed 8mm Pitch, 12mm (0.47 in.) Wide Belts (8M-12)																
22	8MX22S12-1008	1008	2.206	2.143	2.610	AF-1	1.000			0.63	0.88		0.88		0.44	0.5
25	8MX25S12-1108	1108	2.506	2.443	2.910	AF-1	1.125			0.63	0.88		0.88		0.44	0.7
26	8MX26S12-1108	1108	2.607	2.906	2.906	AF-1	1.125			0.63	0.88		0.88		0.44	0.8
27	8MX27S12-1108	1108	2.707	2.644	3.207	AF-1	1.125			0.63	0.88		0.88		0.44	0.9
28	8MX28S12-1108	1108	2.807	2.744	3.210	AF-1	1.125			0.63	0.88		0.88		0.44	1.0
29	8MX29S12-1108	1108	2.907	2.844	3.090	AF-1	1.125			0.63	0.88		0.88		0.44	1.2
30	8MX30S12-1108	1108	3.008	2.945	3.410	AF-1	1.125			0.63	0.88		0.88		0.44	1.3
31	8MX31S12-1210	1210	3.108	3.045	3.328	AF-1	1.250			0.75	1.00		1.00		0.50	1.3
32	8MX32S12-1210	1210	3.208	3.145	3.610	AF-1	1.250			0.75	1.00		1.00		0.50	1.4
33	8MX33S12-1610	1610	3.308	3.245	3.566	AF-1	1.625			0.75	1.00		1.00		0.50	1.3
34	8MX34S12-1610	1610	3.409	3.346	3.810	AF-1	1.625			0.75	1.00		1.00		0.50	1.3
35	8MX35S12-1610	1610	3.509	3.446	3.805	AF-1	1.625			0.75	1.00		1.00		0.50	1.3
36	8MX36S12-1610	1610	3.609	3.456	4.010	AF-1	1.625			0.75	1.00		1.00		0.50	1.2
37	8MX37S12-1610	1610	3.709	3.646	4.044	AF-1	1.625			0.75	1.00		1.00		0.50	1.6
38	8MX38S12-1610	1610	3.810	3.747	4.210	AF-1	1.625			0.75	1.00		1.00		0.50	1.7
39	8MX39S12-1610	1610	3.910	3.847	4.410	AF-1	1.625			0.75	1.00		1.00		0.50	1.7
40	8MX40S12-2012	2012	4.010	3.947	4.410	BF-1	2.000		3.56	0.57	1.25		0.82	0.43	0.41	1.7
41	8MX41S12-2012	2012	4.110	4.047	4.520	BF-1	2.000		3.65	0.65	1.25		0.82	0.43	0.41	1.8
42	8MX42S12-2012	2012	4.211	4.148	4.910	BF-1	2.000		3.76	0.57	1.25		0.82	0.43	0.41	2.2
45	8MX45S12-2012	2012	4.511	4.448	4.910	BF-1	2.000		3.76	0.57	1.25		0.82	0.43	0.41	2.5
48	8MX48S12-2012	2012	4.812	4.749	5.210	BF-1	2.000		3.76	0.57	1.25		0.82	0.43	0.41	3.4
50	8MX50S12-2012	2012	5.013	4.950	5.410	BF-1	2.000		3.76	0.57	1.25		0.82	0.43	0.41	3.7
53	8MX53S12-2012	2012	5.314	5.251	5.500	BF-1	2.000		3.76	0.57	1.25		0.82	0.43	0.41	4.7
56	8MX56S12-2012	2012	5.614	5.551	6.010	BF-1	2.000		3.76	0.57	1.25		0.82	0.43	0.41	5.4
60	8MX60S12-2012	2012	6.015	5.952	6.410	BF-1	2.000		3.76	0.57	1.25		0.82	0.43	0.41	6.3
63	8MX63S12-2012	2012	6.316	6.253	6.720	CF-1	2.000	5.71	4.00	0.57	1.25		0.82	0.43	0.41	5.6
67	8MX67S12-2012	2012	6.717	6.654	6.870	CF-1	2.000	6.14	4.00	0.57	1.25		0.82	0.43	0.41	4.3
71	8MX71S12-2012	2012	7.118	7.055	7.500	CF-1	2.000	6.51	4.00	0.57	1.25		0.82	0.43	0.41	4.7
75	8MX75S12-2012	2012	7.519	7.456	7.920	CF-1	2.000	6.90	4.00	0.57	1.25		0.82	0.43	0.41	5.1
80	8MX80S12-2012	2012	8.020	7.957	8.420	CF-1	2.000	7.23	4.00	0.57	1.25		0.82	0.43	0.41	5.8
90	8MX90S12-2012	2012	9.023	8.96	-	C-2	2.000	8.05	4.00		1.25		0.82	0.43	0.41	9.4
112	8MX112S12-2012	2012	11.229	11.166	-	C-2	2.000	10.25	4.00		1.25		0.82	0.43	0.41	16.6
140	8MX140S12-2012	2012	14.036	13.973	-	C-3	2.000	11.96	4.38		1.25		0.82	0.43	0.41	17.3
180	8MX180S12-2517	2517	18.046	17.893	-	C-3	2.500	15.80	4.88		1.75		0.82	0.93	0.41	30.0
224	8MX224S12-2517	2517	22.457	22.394	-	C-3	2.500	20.17	4.88		1.75		0.82	0.93	0.41	41.2

Type: 1- Solid 2- Web 3- Arms F=Flanged
 NOTE: Weights for Minimum Plain Bore (MPB) Sprockets are with minimum bore.
 Weights for Bushed Sprockets less bushing.
 Dimensions in Inches. Weight in pounds.

MPC® Sprockets | 8mm

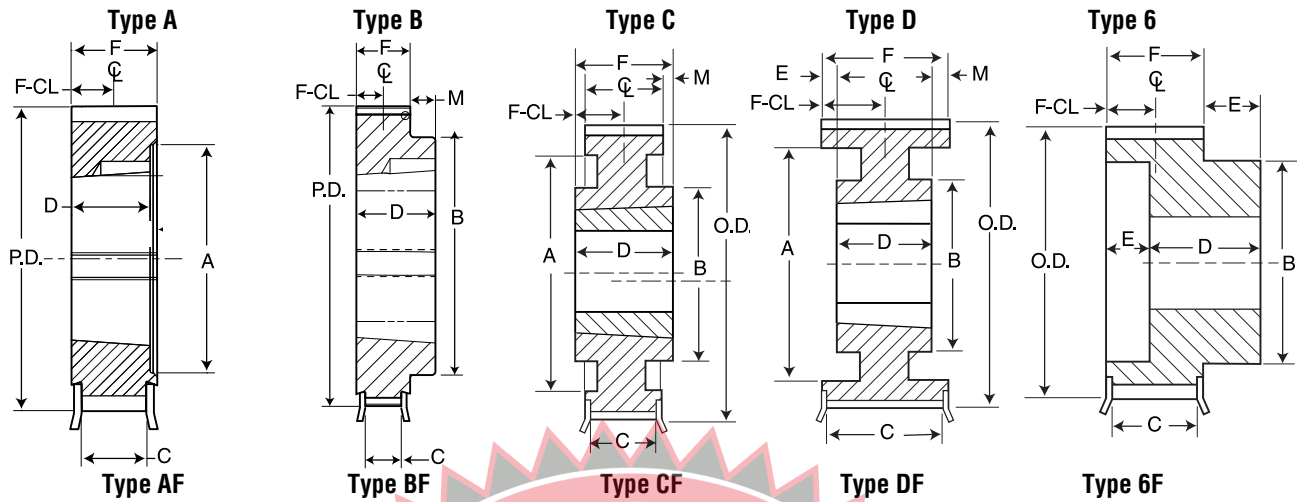

8mm Pitch — 21mm Wide Belt

No. of Teeth	Catalog Number	Bore	Pitch Diameter	Diameter (in.)			Type	Max. Bore	Dimensions (in.)						Weight Approx. (lbs.)	
				O.D.	Max. Flange O.D.				A	B	C	D	E	F		M
MBP 8mm Pitch, 21mm (0.83 in.) Wide Belts (8M-21)																
22	PB8MX22S21	MPB	2.206	2.143	2.610	6F-1	1.188		1.79	0.92	1.65	0.45	1.20		0.60	1.3
25	PB8MX25S21	MPB	2.506	2.443	2.910	6F-1	1.500		2.08	0.92	1.65	0.45	1.20		0.60	1.8
28	PB8MX28S21	MPB	2.807	2.744	3.210	6F-1	1.750		2.34	0.92	1.65	0.45	1.20		0.60	2.3
30	PB8MX30S21	MPB	3.008	2.945	3.410	6F-1	1.813		2.54	0.92	1.77	0.57	1.20		0.60	2.8
32	PB8MX32S21	MPB	3.208	3.145	3.610	6F-1	2.000		2.73	0.92	1.77	0.57	1.20		0.60	3.2
Taper Bushed 8mm Pitch, 21mm (0.83 in.) Wide Belts (8M-21)																
22	8MX22S21-1008	1008	2.206	2.143	2.610	AF-1	1.000	1.63		0.92	0.88		1.20		0.60	0.6
25	8MX25S21-1108	1108	2.506	2.443	2.910	AF-1	1.125	1.92		0.92	0.88		1.20		0.60	0.8
26	8MX26S21-1108	1108	2.607	2.906	2.906	AF-1	1.125	1.85		0.92	0.88		1.20		0.60	0.8
27	8MX27S21-1108	1108	2.707	2.644	3.207	AF-1	1.125	1.95		0.92	0.88		1.20		0.60	1.0
28	8MX28S21-1108	1108	2.807	2.744	3.210	AF-1	1.125	2.18		0.92	0.88		1.20		0.60	1.1
29	8MX29S21-1108	1108	2.907	2.844	3.090	AF-1	1.125	2.15		0.92	0.88		1.20		0.60	1.4
30	8MX30S21-1108	1108	3.008	2.945	3.410	AF-1	1.125	2.38		0.92	0.88		1.20		0.60	1.5
31	8MX31S21-1210	1210	3.108	3.045	3.328	AF-1	1.250	2.35		0.92	1.00		1.20		0.60	1.6
32	8MX32S21-1210	1210	3.208	3.145	3.610	AF-1	1.250	2.58		0.92	1.00		1.20		0.60	3.0
33	8MX33S21-1610	1610	3.308	3.245	3.566	AF-1	1.625	2.6		0.92	1.00		1.20		0.60	1.4
34	8MX34S21-1610	1610	3.409	3.346	3.810	AF-1	1.625	2.66		0.92	1.00		1.20		0.60	1.9
35	8MX35S21-1610	1610	3.509	3.446	3.805	AF-1	1.625	2.75		0.92	1.00		1.20		0.60	1.5
36	8MX36S21-1610	1610	3.609	3.456	4.010	AF-1	1.625	2.96		0.92	1.00		1.20		0.60	1.6
37	8MX37S21-1610	1610	3.709	3.646	4.044	AF-1	1.625	2.95		0.92	1.00		1.20		0.60	1.7
38	8MX38S21-1610	1610	3.810	3.747	4.210	AF-1	1.625	3.15		0.92	1.00		1.20		0.60	1.9
39	8MX39S21-1610	1610	3.910	3.847	4.410	AF-1	1.625	3.14		0.92	1.00		1.20		0.60	2.0
40	8MX40S21-2012	2012	4.010	3.947	4.410	AF-1	2.000			0.97	1.25		1.25		0.63	2.0
41	8MX41S21-2012	2012	4.110	4.047	4.520	BF-1	2.000		3.4	1.00	1.25		1.20		0.60	2.2
42	8MX42S21-2012	2012	4.211	4.148	4.910	AF-1	2.000			0.97	1.25		1.25		0.63	2.4
45	8MX45S21-2012	2012	4.511	4.448	4.910	AF-1	2.000			0.97	1.25		1.25		0.63	3.0
48	8MX48S21-2012	2012	4.812	4.749	5.210	AF-1	2.000			0.97	1.25		1.25		0.63	3.4
50	8MX50S21-2012	2012	5.013	4.950	5.410	AF-1	2.000			0.97	1.25		1.25		0.63	4.2
53	8MX53S21-2012	2012	5.314	5.251	5.500	AF-1	2.000			0.97	1.25		1.25		0.63	5.0
56	8MX56S21-2012	2012	5.614	5.551	6.010	AF-1	2.000			0.97	1.25		1.25		0.63	4.9
60	8MX60S21-2012	2012	6.015	5.952	6.410	AF-1	2.000			0.97	1.25		1.25		0.63	6.9
63	8MX63S21-2012	2012	6.316	6.253	6.720	CF-1	2.000	5.71	3.76	0.92	1.25		1.20	0.05	0.60	7.7
67	8MX67S21-2517	2517	6.717	6.654	6.870	CF-1	2.500	6.14	4.50	0.92	1.75		1.20	0.55	0.60	5.7
71	8MX71S21-2517	2517	7.118	7.055	7.500	CF-1	2.500	6.51	4.50	0.92	1.75		1.20	0.55	0.60	6.1
75	8MX75S21-2517	2517	7.519	7.456	7.920	CF-1	2.500	6.90	4.50	0.92	1.75		1.20	0.55	0.60	9.2
80	8MX80S21-2517	2517	8.020	7.957	8.420	CF-1	2.500	7.23	4.50	0.92	1.75		1.20	0.55	0.60	7.5
90	8MX90S21-2517	2517	9.023	8.96	-	C-2	2.500	7.78	4.50		1.75		1.20	0.55	0.60	11.0
112	8MX112S21-2517	2517	11.229	11.166	-	C-2	2.500	10.00	4.50		1.75		1.20	0.55	0.60	19.4
140	8MX140S21-2517	2517	14.036	13.973	-	C-3	2.500	11.74	4.88		1.75		1.20	0.55	0.60	26.8
180	8MX180S21-3020	3020	18.046	17.893	-	C-3	3.000	15.49	6.25		2.00		1.20	0.80	0.60	36.6
224	8MX224S21-3020	3020	22.457	22.394	-	C-3	3.000	19.86	6.25		2.00		1.20	0.80	0.60	50.1

Type: 1- Solid 2- Web 3- Arms F=Flanged
 NOTE: Weights for Minimum Plain Bore (MPB) Sprockets are with minimum bore.
 Weights for Bushed Sprockets less bushing.
 Dimensions in Inches. Weight in pounds.

8mm | MPC® Sprockets

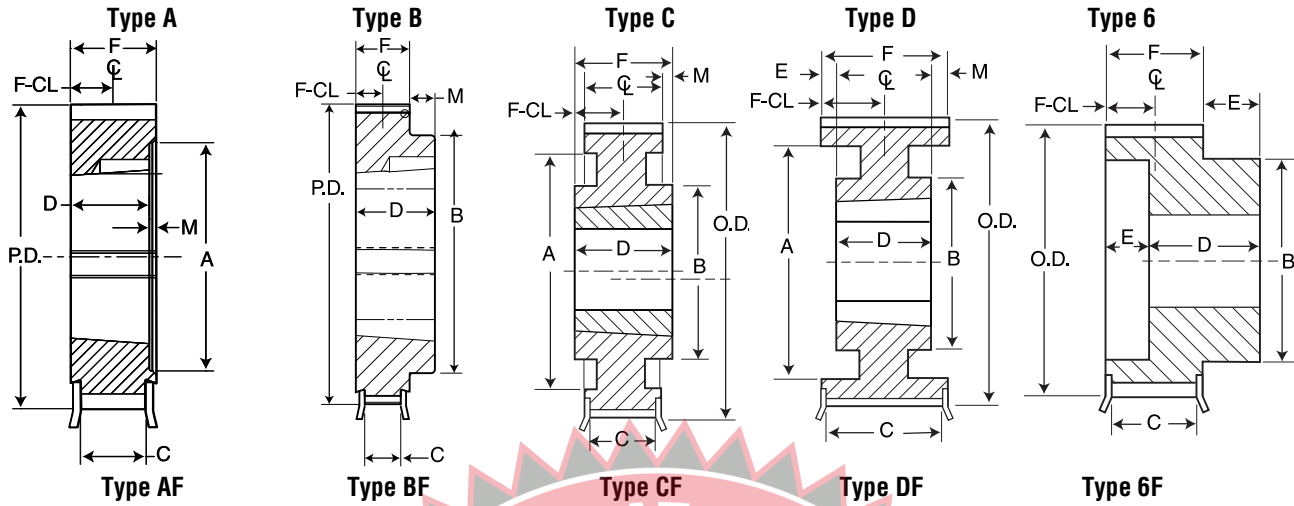

8mm Pitch — 36mm Wide Belt

No. of Teeth	Catalog Number	Bore	Pitch Diameter	Diameter		Type	Max. Bore	Dimensions							Weight Approx. (lbs.)	
				O.D.	Max. Flange O.D.			A	B	C	D	E	F	M		F-CL
MBP 8mm Pitch, 36mm (1.42 in.) Wide Belts (8M-36)																
22	PB8MX22S36	MPB	2.206	2.143	2.610	6F-1	1.188		1.79	1.58	2.44	0.61	1.83		0.93	2.0
25	PB8MX25S36	MPB	2.506	2.443	2.910	6F-1	1.500		2.08	1.58	2.44	0.61	1.83		0.93	2.7
28	PB8MX28S36	MPB	2.807	2.744	3.210	6F-1	1.750		2.34	1.58	2.44	0.61	1.83		0.93	3.5
30	PB8MX30S36	MPB	3.008	2.945	3.410	6F-1	1.813		2.54	1.58	2.44	0.61	1.83		0.93	4.1
32	PB8MX32S36	MPB	3.208	3.145	3.610	6F-1	2.000		2.73	1.58	2.44	0.61	1.83		0.93	3.9
34	PB8MX34S36	MPB	3.409	3.346	3.810	6F-1	2.125		2.82	1.58	2.45	0.62	1.83		0.93	4.3
36	PB8MX36S36	MPB	3.609	3.546	4.010	6F-1	2.313		3.13	1.58	2.51	0.68	1.83		0.93	5.9
38	PB8MX38S36	MPB	3.810	3.747	4.210	6F-1	2.438		3.32	1.58	2.51	0.68	1.83		0.93	6.7
Taper Bushed 8mm Pitch, 36mm (1.42 in.) Wide Belts (8M-36)																
32	8MX32S36-1210	1210	3.208	3.145	3.610	AF-1	1.250	2.58		1.58	1.00		1.83	0.83	0.93	2.0
33	8MX33S36-1610	1610	3.308	3.245	3.566	AF-1	1.625	2.56		1.66	1.00		1.83	0.83	0.93	1.7
34	8MX34S36-1610	1610	3.409	3.346	3.810	AF-1	1.625	2.66		1.58	1.00		1.83	0.83	0.93	1.8
35	8MX35S36-1610	1610	3.509	3.446	3.805	AF-1	1.625	2.76		1.66	1.00		1.83	0.83	0.93	2.0
36	8MX36S36-1610	1610	3.609	3.546	4.010	AF-1	1.625	2.96		1.58	1.00		1.83	0.83	0.93	2.7
37	8MX37S36-1610	1610	3.709	3.646	4.044	AF-1	1.625	2.90		1.66	1.00		1.83	0.83	0.93	2.1
38	8MX38S36-1610	1610	3.810	3.747	4.210	AF-1	1.625	3.15		1.58	1.00		1.83	0.83	0.93	2.9
39	8MX39S36-1610	1610	3.910	3.847	4.410	AF-1	1.625	3.10		1.58	1.00		1.83	0.83	0.93	2.4
40	8MX40S36-2012	2012	4.010	3.947	4.410	AF-1	2.000	3.35		1.58	1.25		1.83	0.58	0.93	2.5
41	8MX41S36-2012	2012	4.110	4.047	4.520	AF-1	2.000	3.36		1.58	1.25		1.83	0.58	0.93	2.4
42	8MX42S36-2012	2012	4.211	4.148	4.910	AF-1	2.000	3.62		1.58	1.25		1.83	0.58	0.93	2.8
45	8MX45S36-2012	2012	4.511	4.448	4.910	AF-1	2.000	3.62		1.58	1.25		1.83	0.58	0.93	4.0
48	8MX48S36-2012	2012	4.812	4.749	5.210	AF-1	2.000	4.14		1.58	1.25		1.83	0.58	0.93	4.3
50	8MX50S36-2012	2012	5.013	4.95	5.410	AF-1	2.000	4.13		1.58	1.25		1.83	0.58	0.93	5.1
53	8MX53S36-2012	2012	5.314	5.251	5.500	AF-1	2.000	4.76		1.58	1.25		1.83	0.58	0.93	6.0
56	8MX56S36-2012	2012	5.614	5.551	6.010	AF-1	2.000	4.92		1.58	1.25		1.83	0.58	0.93	6.5
60	8MX60S36-2517	2517	6.015	5.952	6.420	AF-1	2.500	5.13		1.58	1.75		1.83	0.58	0.93	8.9
63	8MX63S36-2517	2517	6.316	6.253	6.720	AF-1	2.500	5.71		1.58	1.75		1.83	0.08	0.93	9.3
67	8MX67S36-2517	2517	6.717	6.654	6.880	DF-1	2.500	5.98	4.25	1.58	1.75		1.83	0.08	0.93	10.0
71	8MX71S36-2517	2517	7.118	7.055	7.500	DF-1	2.500	6.39	4.25	1.58	1.75		1.83	0.08	0.93	7.0
75	8MX75S36-2517	2517	7.519	7.456	7.920	DF-1	2.500	6.79	4.25	1.58	1.75		1.83	0.08	0.93	13.3
80	8MX80S36-3020	3020	8.020	7.957	8.420	BF-1	3.000		5.75	1.58	2.00		1.83	0.08	0.93	15.3
90	8MX90S36-3020	3020	9.023	8.960	-	B-1	3.000		5.75		2.00		1.83	0.17	0.93	20.9
112	8MX112S36-3020	3020	11.229	11.166	-	C-2	3.000	9.80	5.75		2.00		1.83	0.17	0.93	22.0
140	8MX140S36-3020	3020	14.036	13.973	-	C-3	3.000	11.72	6.25		2.00		1.83	0.17	0.93	39.3
180	8MX180S36-3020	3020	18.046	17.983	-	C-3	3.000	15.31	6.25		2.00		1.83	0.17	0.93	48.9
224	8MX224S36-3525	3525	22.457	22.394	-	C-3	3.500	19.62	8.75		2.50		1.83	0.67	0.93	92.2

Type: 1 - Solid 2 - Web 3 - Arms F=Flanged
 NOTE: Weights for Minimum Plain Bore (MPB) Sprockets are with minimum bore.
 Weights for Bushed Sprockets less bushing.
 Dimensions in Inches. Weight in pounds.

MPC® Sprockets | 8mm

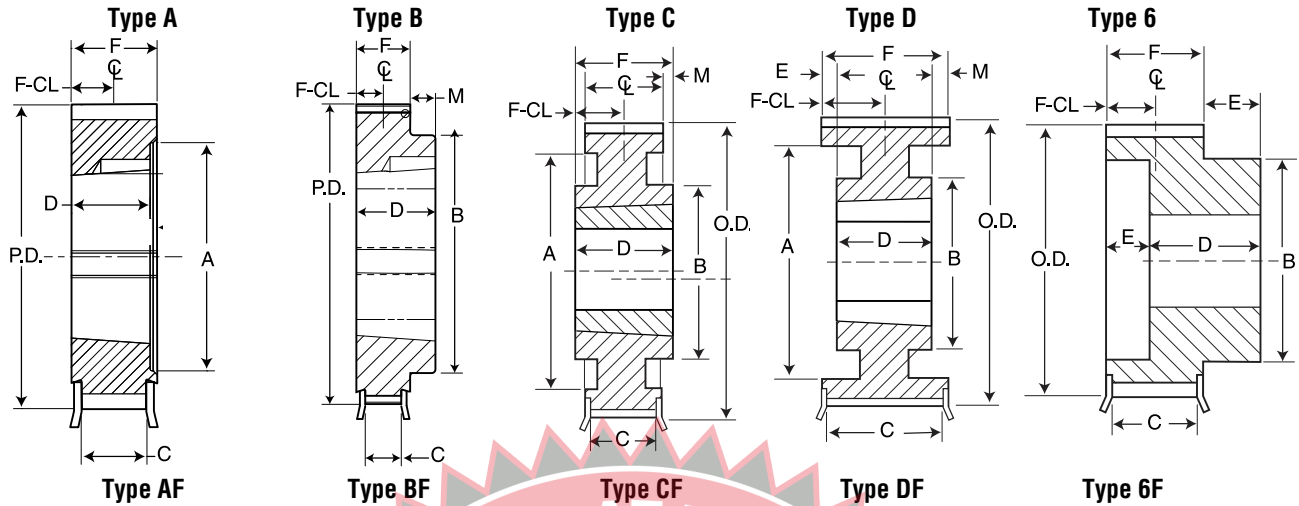

8mm Pitch — 62mm Wide Belt

No. of Teeth	Catalog Number	Bore	Pitch Diameter	Diameter (in.)			Type	Max. Bore	Dimensions (in.)							Weight Approx. (lbs.)
				O.D.	Max. Flange O.D.				A	B	C	D	E	F	M	
MPB® 8mm Pitch, 62mm (2.44 in.) Wide Belts (8M - 62)																
22	PB8MX22S62	MPB	2.206	2.143	2.610	6F-1	1.188		1.79	2.63	3.56	0.68	2.88		1.46	2.4
25	PB8MX25S62	MPB	2.506	2.443	2.910	6F-1	1.500		2.08	2.63	3.56	0.68	2.88		1.46	3.6
28	PB8MX28S62	MPB	2.807	2.744	3.210	6F-1	1.750		2.34	2.63	3.56	0.68	2.88		1.46	4.6
30	PB8MX30S62	MPB	3.008	2.945	3.410	6F-1	1.813		2.54	2.63	3.50	0.62	2.88		1.46	5.3
32	PB8MX32S62	MPB	3.208	3.145	3.610	6F-1	2.000		2.73	2.63	3.50	0.62	2.88		1.46	5.6
34	PB8MX34S62	MPB	3.409	3.346	3.810	6F-1	2.125		2.82	2.63	3.50	0.62	2.88		1.46	5.7
36	PB8MX36S62	MPB	3.609	3.546	4.010	6F-1	2.313		3.13	2.63	3.56	0.68	2.88		1.46	8.0
38	PB8MX38S62	MPB	3.812	3.747	4.210	6F-1	2.438		3.32	2.63	3.56	0.68	2.88		1.46	9.1
40	PB8MX40S62	MPB	4.010	3.947	4.410	6F-1	2.563		3.52	2.63	3.63	0.75	2.88		1.46	10.3
42	PB8MX42S62	MPB	4.211	4.148	4.910	6F-1	2.750		3.79	2.63	3.63	0.75	2.88		1.46	11.6
45	PB8MX45S62	MPB	4.511	4.448	4.910	6F-1	2.750		3.79	2.63	3.63	0.75	2.88		1.46	13.1
Taper Bushed 8mm Pitch, 62mm (2.44 in.) Wide Belts (8M - 62)																
34	8MX34S62-1610	1610	3.409	3.346	3.810	AF-1	1.625	2.66		2.63	1.00		2.88		1.46	5.0
36	8MX36S62-1610	1610	3.609	3.546	4.010	AF-1	1.625	2.96		2.63	1.00		2.88		1.46	5.3
38	8MX38S62-1610	1610	3.812	3.747	4.210	AF-1	1.625	3.15		2.63	1.00		2.88		1.46	5.6
40	8MX40S62-2012	2012	4.010	3.947	4.410	AF-1	2.000	3.35		2.63	1.25		2.88		1.46	5.9
42	8MX42S62-2012	2012	4.211	4.148	4.910	AF-1	2.000	3.62		2.63	1.25		2.88		1.46	3.5
45	8MX45S62-2012	2012	4.511	4.448	4.910	AF-1	2.000	3.62		2.63	1.25		2.88		1.46	6.5
48	8MX48S62-2517	2517	4.812	4.749	5.210	AF-1	2.500	4.14		2.63	1.75		2.88		1.46	6.6
50	8MX50S62-2517	2517	5.013	4.950	5.410	AF-1	2.500	4.13		2.63	1.75		2.88		1.46	6.7
53	8MX53S62-2517	2517	5.314	5.251	5.500	AF-1	2.500	4.76		2.63	1.75		2.88		1.46	6.9
56	8MX56S62-2517	2517	5.614	5.551	6.010	AF-1	2.500	4.92		2.63	1.75		2.88		1.46	7.2
60	8MX60S62-3020	3020	6.015	5.952	6.420	AF-1	3.000	5.13		2.63	2.00		2.88		1.46	8.9
63	8MX63S62-3020	3020	6.316	6.253	6.720	AF-1	3.000	5.71		2.63	2.00		2.88		1.46	10.3
67	8MX67S62-3020	3020	6.717	6.654	6.880	AF-1	3.000	6.14		2.63	2.00		2.88		1.46	11.0
71	8MX71S62-3020	3020	7.118	7.055	7.500	AF-1	3.000	6.51		2.63	2.00		2.88		1.46	13.5
75	8MX75S62-3020	3020	7.519	7.456	7.920	AF-1	3.000	6.90		2.63	2.00		2.88		1.46	15.4
80	8MX80S62-3020	3020	8.020	7.957	8.420	AF-1	3.000	7.23			2.00		2.88		1.46	23.0
90	8MX90S62-3020	3020	9.023	8.960	-	D-1	3.000	7.39	5.42		2.00		2.88	0.91	1.46	32.7
112	8MX112S62-3020	3020	11.229	11.166	-	D-2	3.000	9.60	5.42		2.00		2.88	0.91	1.46	38.9
140	8MX140S62-3525	3525	14.036	13.973	-	D-2	3.500	12.40	8.75		2.50		2.88	0.41	1.46	54.5
180	8MX180S62-3525	3525	18.046	17.983	-	D-3	3.500	15.33	8.75		2.50		2.88	0.41	1.46	90.0
224	8MX224S62-3525	3525	22.457	22.394	-	D-3	3.500	19.38	8.75		2.50		2.88	0.41	1.46	92.3

Type: 1-Solid 2-Web 3-Arms F=Flanged
 NOTE: Weights for Minimum Plain Bore (MPB) Sprockets are with minimum bore.
 Weights for Bushed Sprockets less bushing.
 Dimensions in Inches. Weight in pounds.

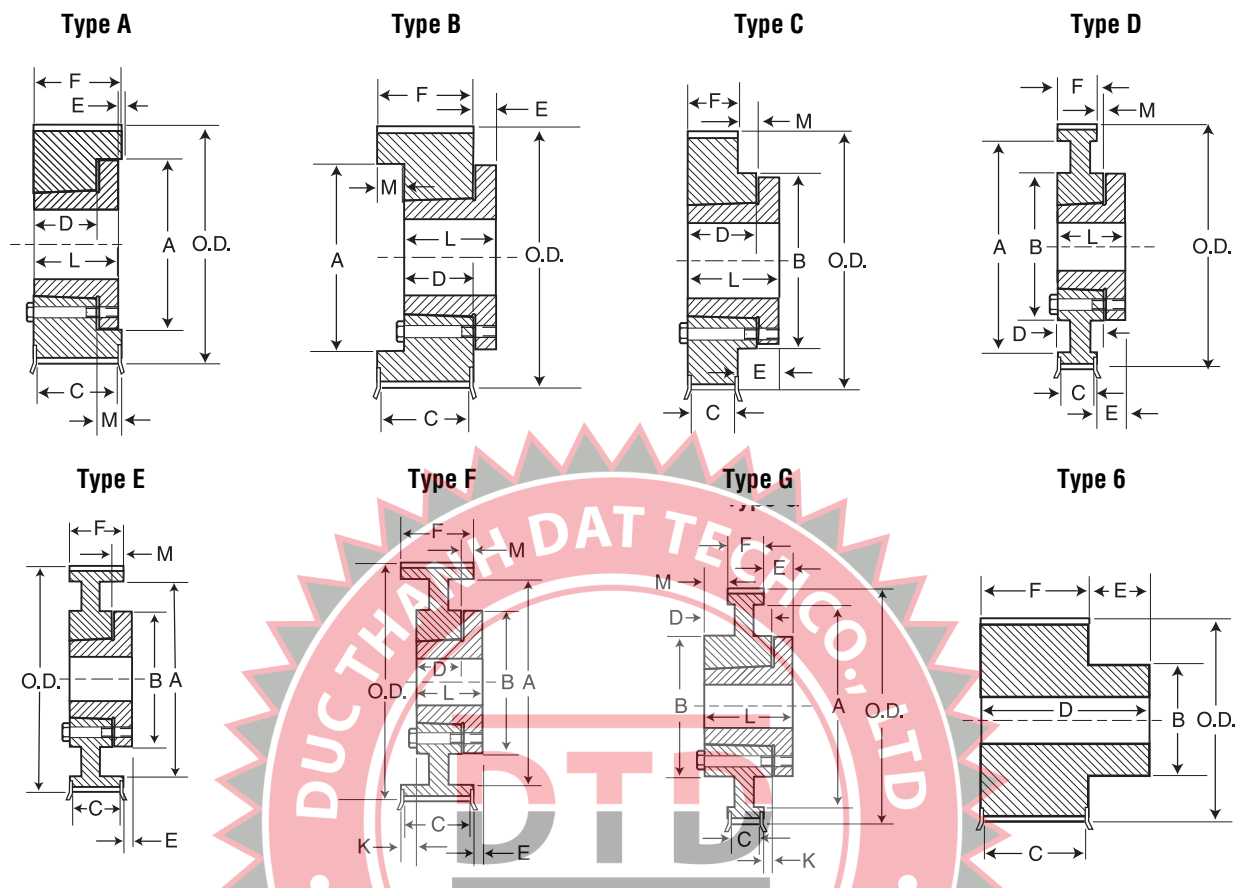

8mm Pitch — 21mm Wide Air Cool Heat Exchange Belt

No. of Teeth	Catalog Number	Bore	Pitch Diameter	Diameter (in.)		Type	Max. Bore	Dimensions (in.)								Weight Approx. (lbs.)	
				O.D.	Max. Flange O.D.			A	B	C	D	E	F	L	M		F-CL
OD Bushed 8mm Pitch, 21mm (0.93 in.) Wide Belt (8M-21)																	
36	F8MX36S21-SH	SH	3.609	3.546	4.009	AF-1	1.688	2.85		0.92	0.81	0.0475	1.20	1.94	0.39	0.60	2.1
38	F8MX38S21-SH	SH	3.810	3.747	4.210	AF-1	1.688	3.04		0.92	0.81	0.0475	1.20	1.94	0.39	0.60	2.1
40	F8MX40S21-SH	SH	4.010	3.947	4.410	AF-1	1.688	3.24		0.92	0.81	0.0475	1.20	1.94	0.39	0.60	2.3
42	F8MX42S21-SH	SH	4.211	4.148	4.911	AF-1	1.688	3.44		0.92	0.81	0.0475	1.20	1.94	0.39	0.60	2.5
140	F8MX140S21-SF	SF	14.036	13.973		C-1	2.938	13.17	6.38		1.25	0.6125	1.20	2.06	0.05	0.60	25.0
168	F8MX168S21-SF	SF	16.843	16.780		C-3	2.938	15.95	6.38		1.25	0.6125	1.20	2.06	0.05	0.60	33.8
180	F8MX180S21-SF	SF	18.046	17.983		C-3	2.938	17.14	6.38		1.25	1.305	1.20	2.06	0.03	0.60	36.6
224	F8MX224S21-E	E	22.457	22.394		C-3	3.500	21.51	7.50		1.25	1.305	1.20	2.75	0.43	0.60	50.1

Type: 1- Solid 2- Web 3- Arms F=Flanged
 NOTE: Weights for Minimum Plain Bore (MPB) Sprockets are with minimum bore.
 Weights for Bushed Sprockets less bushing.
 Dimensions in Inches. Weight in pounds.

MPC® Sprockets | 14mm

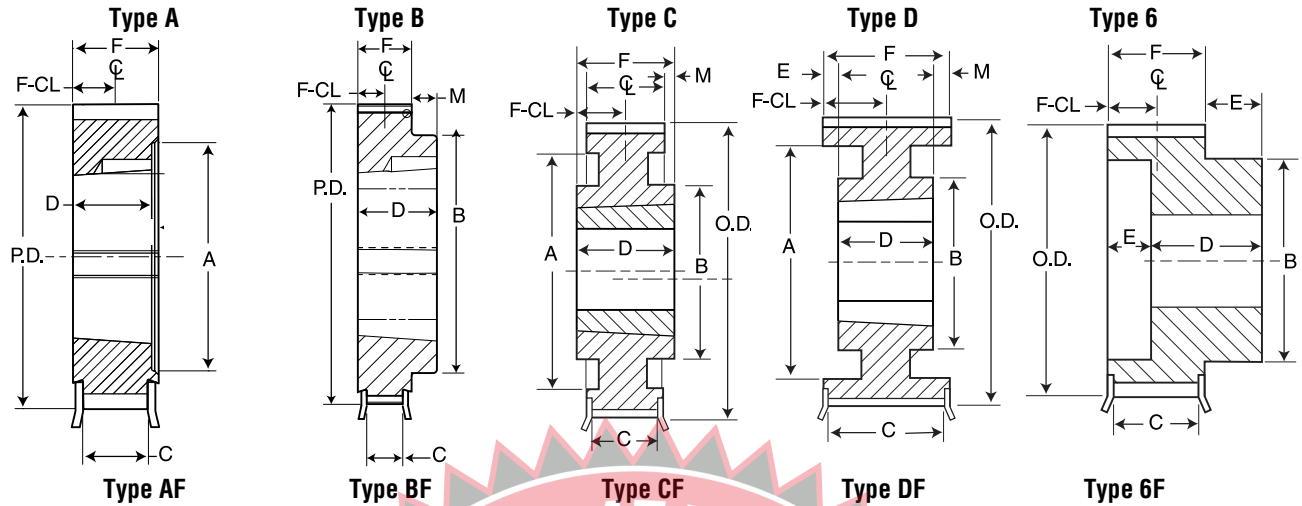

14mm Pitch — 20mm Wide Belt

No. of Teeth	Catalog Number	Bore	Pitch Diameter	Diameter		Type	Max. Bore	Dimensions (in.)							Weight Approx. (lbs.)	
				O.D.	Max. Flange O.D.			A	B	C	D	E	F	M		F-CL
Tapered Bushed 14mm Pitch, 20mm (.826 in.) Wide Belt (14M-20)																
28	14MX28S20-2012	2012	4.912	4.802	5.400	AF-1	2.00	3.61		1.04	1.25		1.352		0.68	3.9
29	14MX29S20-2012	2012	5.188	4.978	5.760	AF-1	2.00	3.99		1.04	1.25		1.352		0.68	4.5
30	14MX30S20-2012	2012	5.263	5.153	5.760	AF-1	2.00	3.99		1.04	1.25		1.352		0.68	4.8
31	14MX31S20-2012	2012	5.439	5.329	6.110	AF-1	2.00	4.22		1.04	1.25		1.352		0.68	5.5
32	14MX32S20-2012	2012	5.614	5.504	6.110	AF-1	2.00	4.22		1.04	1.25		1.352		0.68	5.9
33	14MX33S20-2012	2012	5.790	5.680	6.460	AF-1	2.00	4.53		1.04	1.25		1.352		0.68	6.3
34	14MX34S20-2012	2012	5.965	5.855	6.460	AF-1	2.00	4.53		1.04	1.25		1.352		0.68	6.9
35	14MX35S20-2012	2012	6.141	6.031	6.820	AF-1	2.00	4.95		1.04	1.25		1.352		0.68	7.3
36	14MX36S20-2517	2517	6.316	6.206	6.820	BF-1	2.50		4.25	1.04	1.75		1.352	0.40	0.68	7.6
37	14MX37S20-2517	2517	6.492	6.382	7.170	BF-1	2.50		4.25	1.04	1.75		1.352	0.40	0.68	8.2
38	14MX38S20-2517	2517	6.667	6.557	7.170	BF-1	2.50		4.25	1.04	1.75		1.352	0.40	0.68	8.9
39	14MX39S20-2517	2517	6.842	6.732	7.520	BF-1	2.50		4.25	1.04	1.75		1.352	0.40	0.68	9.8
40	14MX40S20-2517	2517	7.018	6.908	7.520	BF-1	2.50		4.25	1.04	1.75		1.352	0.40	0.68	10.1
43	14MX43S20-2517	2517	7.544	7.434	8.040	BF-1	2.50		4.25	1.04	1.75		1.352	0.40	0.68	11.7
45	14MX45S20-3020	3020	7.895	7.785	8.400	BF-1	3.00		5.41	1.04	2.00		1.352	0.65	0.68	13.5
48	14MX48S20-3020	3020	8.421	8.311	8.940	BF-1	3.00		5.75	1.04	2.00		1.352	0.65	0.68	16.4
50	14MX50S20-3020	3020	8.772	8.662	9.290	BF-1	3.00		5.75	1.04	2.00		1.352	0.65	0.68	18.2
53	14MX53S20-3020	3020	9.299	9.189	9.690	BF-1	3.00		5.75	1.04	2.00		1.352	0.65	0.68	20.5
56	14MX56S20-3525	3525	9.825	9.715	10.360	BF-1	3.50		8.75	1.04	2.50		1.352	1.15	0.68	23.2
60	14MX60S20-3525	3525	10.527	10.417	11.070	BF-1	3.50		8.75	1.04	2.50		1.352	1.15	0.68	27.5
63	14MX63S20-3525	3525	11.053	10.943	11.590	BF-1	3.50		8.75	1.04	2.50		1.352	1.15	0.68	30.2
67	14MX67S20-3525	3525	11.755	11.645	12.500	BF-1	3.50		8.75	1.04	2.50		1.352	1.15	0.68	31.2
71	14MX71S20-3525	3525	12.457	12.347	13.070	CF-1	3.50	11.05	8.75	1.04	2.50		1.352	1.15	0.68	32.5
75	14MX75S20-3525	3525	13.158	13.048	13.730	CF-1	3.50	11.68	8.75	1.04	2.50		1.352	1.15	0.68	36.2
80	14MX80S20-3525	3525	14.036	13.926	14.620	CF-2	3.50	12.56	8.75	1.04	2.50		1.352	1.15	0.68	35.4
90	14MX90S20-3525	3525	15.790	15.680		C-2	3.50	14.26	8.75		2.50		1.352	1.15	0.68	41.3
112	14MX112S20-3525	3525	19.650	19.540		C-3	3.50	16.47	8.75		2.50		1.352	1.15	0.68	59.6
140	14MX140S20-3525	3525	24.562	24.452		C-3	3.50	21.04	8.75		2.50		1.352	1.15	0.68	102.0
168	14MX168S20-3525	3525	29.475	29.365		C-3	3.50	25.90	8.75		2.50		1.352	1.15	0.68	99.5
180	14MX180S20-3525	3525	31.580	31.470		C-3	3.50	27.99	8.75		2.50		1.352	1.15	0.68	135.0
200	14MX200S20-3525	3525	35.089	24.979		C-3	3.50	31.46	8.75		2.50		1.352	1.15	0.68	156.0
224	14MX224S20-4030	4030	39.300	39.190		C-3	4.00	35.63	10.00		3.00		1.352	1.65	0.68	150.2

Type: 1 - Solid 2 - Web 3 - Arms F=Flanged
 NOTE: Weights for Minimum Plain Bore (MPB) Sprockets are with minimum bore.
 Weights for Bushed Sprockets less bushing.
 Dimensions in Inches. Weight in pounds.

14mm | MPC® Sprockets

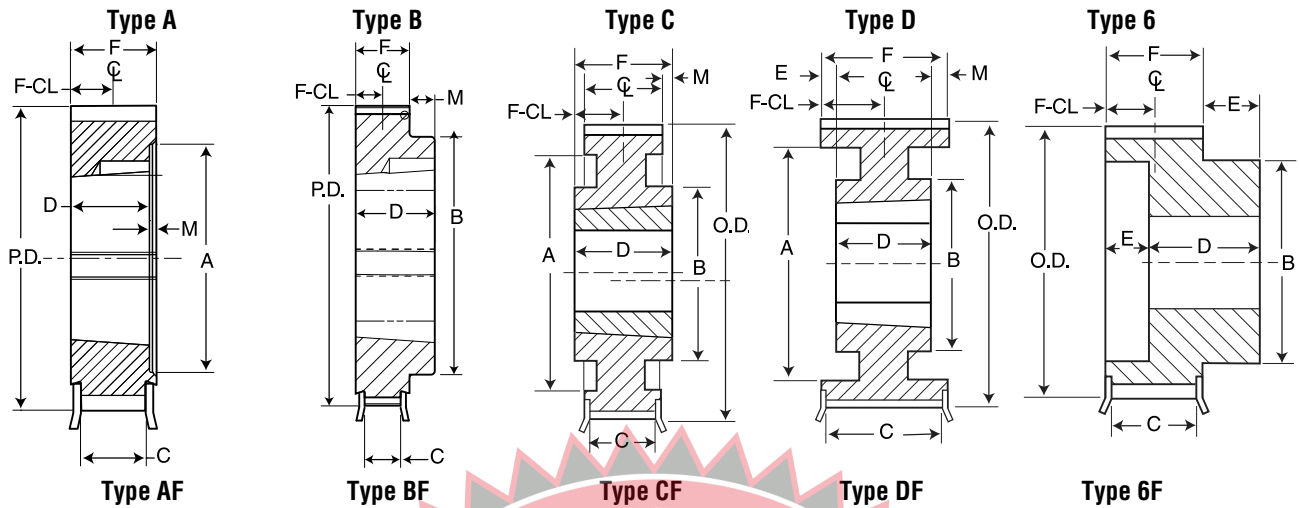

14mm Pitch — 37mm Wide Belt

No. of Teeth	Catalog Number	Bore	P.D.	Diameter (in.)		Type	Max. Bore	Dimensions (in.)							Weight Approx. (lbs.)
				O.D.	Max. Flange O.D.			A	B	C	D	E	F	M	
MPB 14mm Pitch, 37mm (1.46 in.) Wide Belt (14M-37)															
28	PB14MX28S37	MPB	4.912	4.802	5.400	6F-1	2.938	3.97	1.74	2.86	0.80	2.06		1.03	11.7
Taper Bushed 14mm Pitch, 37mm (1.46 in.) Wide Belt (14M-37)															
28	14MX28S37-2012	2012	4.912	4.802	5.400	AF-1	2.00	3.61	1.74	1.25		2.06	0.81	1.03	4.2
29	14MX29S37-2517	2517	5.088	4.978	5.760	AF-1	2.50	3.99	1.74	1.75		2.06	0.31	1.03	4.7
30	14MX30S37-2517	2517	5.263	5.153	5.760	AF-1	2.50	3.99	1.74	1.75		2.06	0.31	1.03	5.0
31	14MX31S37-2517	2517	5.439	5.329	6.110	AF-1	2.50	4.22	1.74	1.75		2.06	0.31	1.03	6.0
32	14MX32S37-2517	2517	5.614	5.504	6.110	AF-1	2.50	4.22	1.74	1.75		2.06	0.31	1.03	7.2
33	14MX33S37-2517	2517	5.790	5.680	6.460	AF-1	2.50	4.53	1.74	1.75		2.06	0.31	1.03	7.5
34	14MX34S37-2517	2517	5.965	5.855	6.460	AF-1	2.50	4.53	1.74	1.75		2.06	0.31	1.03	7.8
35	14MX35S37-2517	2517	6.141	6.031	6.820	AF-1	2.50	4.95	1.74	1.75		2.06	0.31	1.03	8.3
36	14MX36S37-2517	2517	6.316	6.206	6.820	AF-1	2.50	4.95	1.74	1.75		2.06	0.31	1.03	8.8
37	14MX37S37-2517	2517	6.492	6.382	7.170	AF-1	2.50	5.27	1.74	1.75		2.06	0.31	1.03	9.3
38	14MX38S37-3020	3020	6.667	6.557	7.170	AF-1	3.00	5.27	1.74	2.00		2.06	0.06	1.03	10.8
39	14MX39S37-3020	3020	6.842	6.732	7.520	AF-1	3.00	5.54	1.74	2.00		2.06	0.06	1.03	11.9
40	14MX40S37-3020	3020	7.018	6.908	7.520	AF-1	3.00	5.54	1.74	2.00		2.06	0.06	1.03	12.2
43	14MX43S37-3020	3020	7.544	7.434	8.040	AF-1	3.00	6.16	1.74	2.00		2.06	0.06	1.03	12.5
45	14MX45S37-3020	3020	7.895	7.785	8.400	AF-1	3.00	6.42	1.74	2.00		2.06	0.06	1.03	15.8
48	14MX48S37-3020	3020	8.421	8.311	8.940	AF-1	3.00	6.96	1.74	2.00		2.06	0.06	1.03	18.7
50	14MX50S37-3020	3020	8.772	8.662	9.290	AF-1	3.00	7.44	1.74	2.00		2.06	0.06	1.03	21.1
53	14MX53S37-3020	3020	9.299	9.189	9.690	AF-1	3.00	7.84	1.74	2.00		2.06	0.06	1.03	24.7
56	14MX56S37-3525	3525	9.825	9.715	10.360	BF-1	3.50	8.70	1.74	2.50		2.06	0.44	1.03	28.2
60	14MX60S37-3525	3525	10.527	10.417	11.070	BF-1	3.50	8.75	1.74	2.50		2.06	0.44	1.03	32.2
63	14MX63S37-3525	3525	11.053	10.943	11.590	BF-1	3.50	8.75	1.74	2.50		2.06	0.44	1.03	42.8
67	14MX67S37-3525	3525	11.755	11.645	12.500	BF-1	3.50	8.75	1.74	2.50		2.06	0.44	1.03	43.5
71	14MX71S37-3525	3525	12.457	12.347	13.070	BF-1	3.50	8.75	1.74	2.50		2.06	0.44	1.03	44.1
75	14MX75S37-3525	3525	13.158	13.048	13.730	CF-1	3.50	11.68	8.75	1.74	2.50	2.06	0.44	1.03	45.5
80	14MX80S37-3525	3525	14.036	13.926	14.620	CF-2	3.50	12.56	8.75	1.74	2.50	2.06	0.44	1.03	48.7
90	14MX90S37-3525	3525	15.790	15.680		C-2	3.50	14.26	8.75	2.50		2.06	0.44	1.03	53.3
112	14MX112S37-3525	3525	19.650	19.540		C-3	3.50	16.39	8.75	2.50		2.06	0.44	1.03	87.0
126	14MX126S37-3525	3525	22.106	21.996		C-3	3.50	20.56	8.75	2.50		2.06	0.44	1.03	76.3
140	14MX140S37-3525	3525	24.562	24.452		C-3	3.50	20.84	8.75	2.50		2.06	0.44	1.03	100.9
154	14MX154S37-3525	3525	27.019	26.909		C-3	3.50	25.42	8.75	2.50		2.06	0.44	1.03	125.5
168	14MX168S37-4030	4030	29.475	29.365		C-3	4.00	25.51	10.00	3.00		2.06	0.94	1.03	175.1
180	14MX180S37-4030	4030	31.580	31.470		C-3	4.00	27.59	10.00	3.00		2.06	0.94	1.03	191.4
200	14MX200S37-4030	4030	35.089	34.979		C-3	4.00	31.07	10.00	3.00		2.06	0.94	1.03	224.8
224	14MX224S37-4030	4030	39.300	39.190		C-3	4.00	35.24	10.00	3.00		2.06	0.94	1.03	267.7

Type: 1- Solid 2- Web 3- Arms F=Flanged
 NOTE: Weights for Minimum Plain Bore (MPB) Sprockets are with minimum bore.
 Weights for Bushed Sprockets less bushing.
 Dimensions in Inches. Weight in pounds.

MPC® Sprockets | 14mm

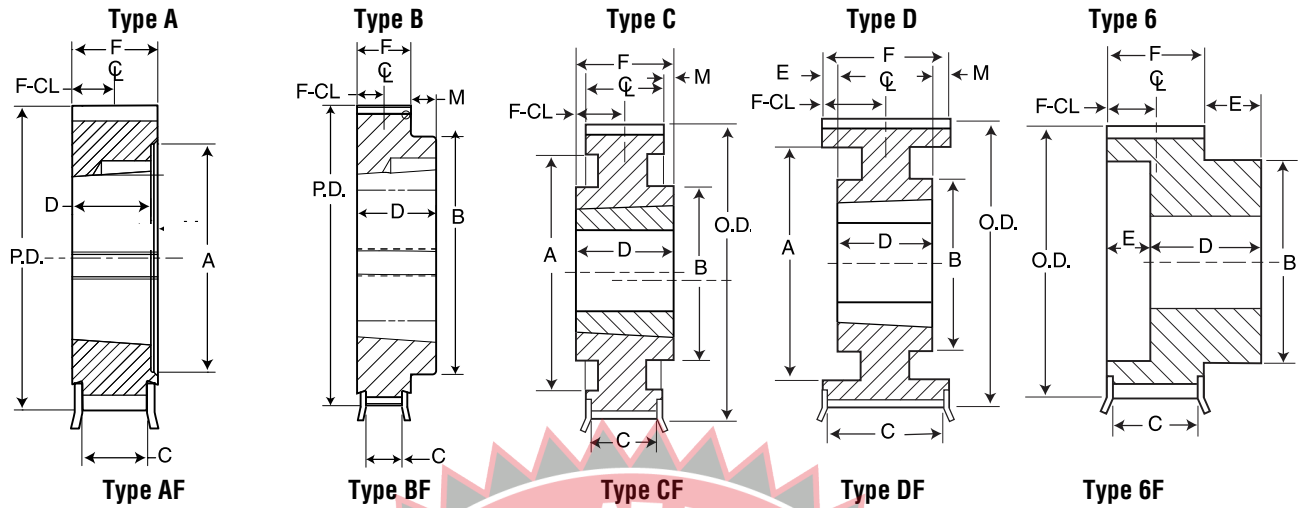

14mm Pitch — 68mm Wide Belt

No. of Teeth	Catalog Number	Bore	Pitch Diameter	Diameter (in.)		Type	Max. Bore	Dimensions (in.)							Weight Approx. (lbs.)	
				O.D.	Max. Flange O.D.			A	B	C	D	E	F	M		F-CL
MPB 14mm Pitch, 68mm (2.68 in.) Wide Belt (14M-68)																
28	PB14MX28S68	MPB	4.912	4.802	5.400	6F-1	2.938	3.97	3.01	4.13	0.81	3.322		1.66	17.0	
29	PB14MX29S68	MPB	5.088	4.978	5.760	6F-1	3.188	4.35	3.01	4.13	0.81	3.322		1.66	19.0	
30	PB14MX30S68	MPB	5.263	5.153	5.760	6F-1	3.188	4.35	3.01	4.13	0.81	3.322		1.66	20.0	
31	PB14MX31S68	MPB	5.439	5.329	6.110	6F-1	3.438	4.57	3.01	4.13	0.81	3.322		1.66	16.8	
32	PB14MX32S68	MPB	5.614	5.504	6.110	6F-1	3.438	4.57	3.01	4.13	0.81	3.322		1.66	18.0	
33	PB14MX33S68	MPB	5.790	5.680	6.470	6F-1	3.500	4.89	3.01	4.33	1.01	3.322		1.66	26.0	
34	PB14MX34S68	MPB	5.965	5.855	6.470	6F-1	3.500	4.89	3.01	4.33	1.01	3.322		1.66	21.1	
Taper Bushed 14mm Pitch, 68mm (2.68 in.) Wide Belt (14M-68)																
29	14MX29S68-2517	2517	5.088	4.978	5.760	AF-1	2.500	3.99		3.01	1.75		3.322		1.66	14.7
30	14MX30S68-2517	2517	5.263	5.153	5.760	AF-1	2.500	3.99		3.01	1.75		3.322		1.66	14.0
31	14MX31S68-2517	2517	5.439	5.329	6.110	AF-1	2.500	4.22		3.01	1.75		3.322		1.66	14.3
32	14MX32S68-2517	2517	5.614	5.504	6.110	AF-1	2.500	4.22		3.01	1.75		3.322		1.66	14.6
33	14MX33S68-2517	2517	5.790	5.680	6.460	AF-1	2.500	4.53		3.01	1.75		3.322		1.66	14.9
34	14MX34S68-2517	2517	5.965	5.855	6.460	AF-1	2.500	4.53		3.01	1.75		3.322		1.66	15.2
35	14MX35S68-3020	3020	6.141	6.031	6.820	AF-1	3.000	4.95		3.01	2.00		3.322		1.66	15.5
36	14MX36S68-3020	3020	6.316	6.206	6.820	AF-1	3.000	4.95		3.01	2.00		3.322		1.66	15.8
37	14MX37S68-3020	3020	6.492	6.382	7.170	AF-1	3.000	5.27		3.01	2.00		3.322		1.66	16.1
38	14MX38S68-3020	3020	6.667	6.557	7.170	AF-1	3.000	5.27		3.01	2.00		3.322		1.66	16.4
39	14MX39S68-3020	3020	6.842	6.732	7.520	AF-1	3.000	5.54		3.01	2.00		3.322		1.66	16.7
40	14MX40S68-3020	3020	7.018	6.908	7.520	AF-1	3.000	5.54		3.01	2.00		3.322		1.66	17.0
43	14MX43S68-3020	3020	7.544	7.434	8.040	AF-1	3.000	6.16		3.01	2.00		3.322		1.66	17.2
45	14MX45S68-3020	3020	7.895	7.785	8.390	AF-1	3.000	6.42		3.01	2.00		3.322		1.66	20.4
48	14MX48S68-3525	3525	8.421	8.311	8.940	AF-1	3.500	6.96		3.01	2.50		3.322		1.66	24.6
50	14MX50S68-3525	3525	8.772	8.662	9.290	AF-1	3.500	7.44		3.01	2.50		3.322		1.66	29.4
53	14MX53S68-3525	3525	9.299	9.189	9.690	AF-1	3.500	7.84		3.01	2.50		3.322		1.66	35.7
56	14MX56S68-3525	3525	9.825	9.715	10.360	AF-1	3.500	8.35		3.01	2.50		3.322		1.66	39.9
60	14MX60S68-3525	3525	10.527	10.417	11.070	AF-1	3.500	9.06		3.01	2.50		3.322		1.66	50.6
63	14MX63S68-3525	3525	11.053	10.943	11.590	AF-1	3.500	9.59		3.01	2.50		3.322		1.66	58.0
67	14MX67S68-3525	3525	11.755	11.645	12.500	DF-1	3.500	10.36	8.75	3.01	2.50		3.322	0.82	1.66	60.0
71	14MX71S68-3525	3525	12.457	12.347	13.070	DF-1	3.500	11.05	8.75	3.01	2.50		3.322	0.82	1.66	63.3
75	14MX75S68-3525	3525	13.158	13.048	13.730	DF-1	3.500	11.68	8.75	3.01	2.50		3.322	0.82	1.66	68.6
80	14MX80S68-3525	3525	14.036	13.926	14.620	DF-2	3.500	12.56	8.75	3.01	2.50		3.322	0.82	1.66	76.3
90	14MX90S68-4030	4030	15.790	15.680		D-2	4.000	14.26	10.00		3.00		3.322	0.32	1.66	82.6
112	14MX112S68-4030	4030	19.650	19.540		D-3	4.000	16.35	10.00		3.00		3.322	0.32	1.66	100.4
140	14MX140S68-4030	4030	24.562	24.452		D-3	4.500	20.78	10.00		3.00		3.322	0.32	1.66	190.0
168	14MX168S68-4535	4535	29.475	29.365		C-3	4.500	25.23	10.50		3.50		3.322	0.18	1.66	239.1
180	14MX180S68-4353	4535	31.580	31.470		C-3	4.500	27.16	10.50		3.50		3.322	0.18	1.66	250.6
200	14MX200S68-4535	4535	35.089	34.979		C-3	4.500	30.65	10.50		3.50		3.322	0.18	1.66	262.5
224	14MX224S68-5040	5040	39.300	39.190		C-3	5.000	34.82	11.00		4.00		3.322	0.68	1.66	350.0

Type: 1 - Solid 2 - Web 3 - Arms F = Flanged
 NOTE: Weights for Minimum Plain Bore (MPB) Sprockets are with minimum bore.
 Weights for Bushed Sprockets less bushing.
 Dimensions in Inches. Weight in pounds.

14mm | MPC® Sprockets

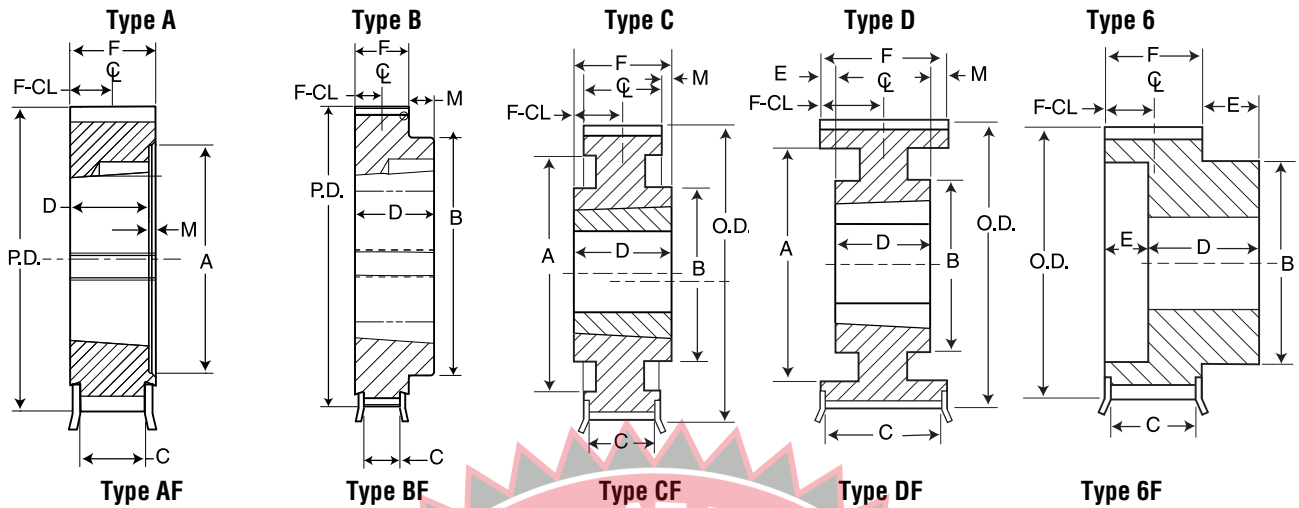

14mm Pitch — 90mm Wide Belt

No. of Teeth	Catalog Number	Bore	P.D.	Diameter (in)		Type	Max. Bore	Dimensions (in)							Weight Approx. (lbs.)
				O.D.	Max. Flange O.D.			A	B	C	D	E	F	M	
MPB 14mm Pitch, 90mm (3.54 in.) Wide Belt (14M-90)															
28	PB14MX28S90	MPB	4.912	4.802	5.400	6F-1		3.97	3.88	5.14	0.95	4.192		2.10	20.0
29	PB14MX29S90	MPB	5.088	4.978	5.760	6F-1		4.35	3.88	5.00	0.81	4.192		2.10	22.1
30	PB14MX30S90	MPB	5.263	5.153	5.760	6F-1		4.35	3.88	5.00	0.81	4.192		2.10	24.0
31	PB14MX31S90	MPB	5.439	5.329	6.110	6F-1		4.57	3.88	5.00	0.81	4.192		2.10	21.8
32	PB14MX32S90	MPB	5.614	5.504	6.110	6F-1		4.57	3.88	5.00	0.81	4.192		2.10	27.0
33	PB14MX33S90	MPB	5.790	5.680	6.470	6F-1		4.89	3.88	5.20	1.01	4.192		2.10	30.0
34	PB14MX34S90	MPB	5.965	5.855	6.470	6F-1		4.89	3.88	5.20	1.01	4.192		2.10	27.2
35	PB14MX35S90	MPB	6.141	6.031	6.820	6F-1		5.30	3.88	5.20	1.01	4.192		2.10	28.7
36	PB14MX36S90	MPB	6.316	6.206	6.820	6F-1		5.30	3.88	5.20	1.01	4.192		2.10	30.3
37	PB14MX90S90	MPB	6.492	6.382	7.170	6F-1		5.63	3.88	5.20	1.01	4.192		2.10	32.1
38	PB14MX38S90	MPB	6.667	6.557	7.170	6F-1		5.63	3.88	5.20	1.01	4.192		2.10	33.9
39	PB14MX39S90	MPB	6.842	6.732	7.500	6F-1		5.89	3.88	5.20	1.01	4.192		2.10	35.8
40	PB14MX40S90	MPB	7.018	6.908	7.520	6F-1		5.89	3.88	5.20	1.01	4.192		2.10	37.7
Taper Bushed 14mm Pitch, 90mm (3.54 in.) Wide Belt (14M-90)															
35	14MX35S90-3020	3020	6.141	6.031	6.820	AF-1	3.00	4.95	3.88	2.00		4.192	2.19	2.10	22.9
36	14MX36S90-3020	3020	6.316	6.206	6.820	AF-1	3.00	4.95	3.88	2.00		4.192	2.19	2.10	23.1
37	14MX90S90-3020	3020	6.492	6.382	7.170	AF-1	3.00	5.27	3.88	2.00		4.192	2.19	2.10	23.4
38	14MX38S90-3020	3020	6.667	6.557	7.170	AF-1	3.00	5.27	3.88	2.00		4.192	2.19	2.10	23.7
39	14MX39S90-3020	3020	6.842	6.732	7.520	AF-1	3.00	5.54	3.88	2.00		4.192	2.19	2.10	24.0
40	14MX40S90-3020	3020	7.018	6.908	7.520	AF-1	3.00	5.54	3.88	2.00		4.192	2.19	2.10	24.3
43	14MX43S90-3525	3525	7.544	7.434	8.040	AF-1	3.50	6.16	3.88	2.50		4.192	1.69	2.10	24.7
45	14MX45S90-3525	3525	7.895	7.785	8.390	AF-1	3.50	6.42	3.88	2.50		4.192	1.69	2.10	27.3
48	14MX48S90-3525	3525	8.421	8.311	8.940	AF-1	3.50	6.96	3.88	2.50		4.192	1.69	2.10	33.4
50	14MX50S90-3525	3525	8.772	8.662	9.290	AF-1	3.50	7.44	3.88	2.50		4.192	1.69	2.10	29.3
53	14MX53S90-3525	3525	9.299	9.189	9.690	AF-1	3.50	7.83	3.88	2.50		4.192	1.69	2.10	46.8
56	14MX56S90-4030	4030	9.825	9.715	10.360	AF-1	4.00	8.35	3.88	3.00		4.192	1.69	2.10	42.1
60	14MX60S90-4030	4030	10.527	10.417	11.070	AF-1	4.00	9.06	3.88	3.00		4.192	1.69	2.10	50.5
63	14MX63S90-4030	4030	11.053	10.943	11.590	AF-1	4.00	9.59	3.88	3.00		4.192	1.69	2.10	64.6
67	14MX67S90-4030	4030	11.755	11.645	12.500	AF-1	4.00	9.88	3.88	3.00		4.192	1.69	2.10	70.0
71	14MX71S90-4030	4030	12.457	12.347	13.070	AF-1	4.00	10.67	3.88	3.00		4.192	1.69	2.10	86.7
75	14MX75S90-4030	4030	13.158	13.048	13.730	AF-1	4.00	11.63	3.88	3.00		4.192	1.69	2.10	85.0
80	14MX80S90-4030	4030	14.036	13.926	14.620	DF-1	4.00	12.56	10.00	3.00		4.192	1.69	2.10	88.0
90	14MX90S90-4030	4030	15.790	15.680		D-2	4.00	14.26	10.00	3.00		4.192	1.69	2.10	89.0
112	14MX112S90-4535	4535	19.650	19.540		D-2	4.50	16.35	10.50	3.50		4.192	0.69	2.10	197.9
140	14MX140S90-5040	5040	24.562	24.452		D-3	5.00	20.74	11.00	4.00		4.192	0.19	2.10	240.0
168	14MX168S90-6050	6050	29.475	29.365		C-3	6.00	25.11	15.50	5.00		4.192	0.81	2.10	327.3
180	14MX180S90-6050	6050	31.580	31.470		C-3	6.00	27.06	15.50	5.00		4.192	0.81	2.10	335.9
200	14MX200S90-6050	6050	35.089	34.979		C-3	6.00	30.29	15.50	5.00		4.192	0.81	2.10	344.5
224	14MX224S90-6050	6050	39.300	39.190		C-3	6.00	34.46	15.50	5.00		4.192	0.81	2.10	589.0

Type: 1- Solid 2- Web 3- Arms F=Flanged

NOTE: Weights for Minimum Plain Bore (MPB) Sprockets are with minimum bore.

Weights for Bushed Sprockets less bushing.

MPC® Sprockets | 14mm

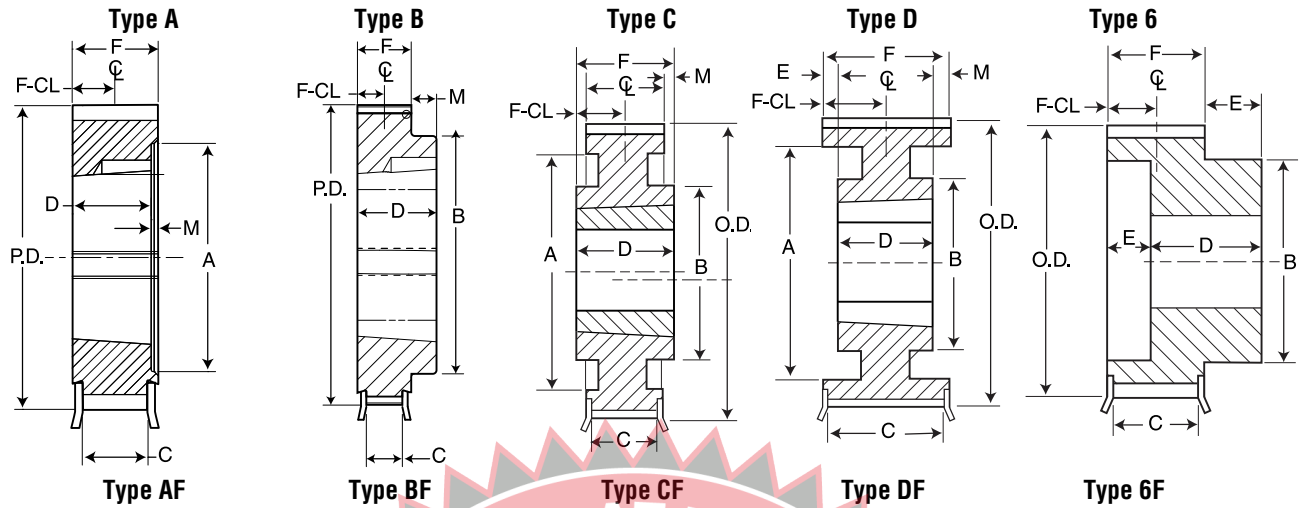

14mm Pitch — 125mm Wide Belt

No. of Teeth	Catalog Number	Bore	Pitch Diameter	Diameter		Type	Max. Bore	Dimensions (in.)							Weight Approx. (lbs.)	
				O.D.	Max. Flange O.D.			A	B	C	D	E	F	M		F-CL
MPB 14mm Pitch, 125mm (4.92 in.) Wide Belt (14M-125)																
28	PB14MX28S125	MPB	4.912	4.802	5.400	6F-1	2.938		3.97	5.29	6.50	0.89	5.61		2.81	22.0
29	PB14MX29S125	MPB	5.088	4.978	5.760	6F-1	3.188		4.35	5.29	6.50	0.89	5.61		2.81	27.0
30	PB14MX30S125	MPB	5.263	5.153	5.760	6F-1	3.188		4.35	5.29	6.50	0.89	5.61		2.81	30.2
31	PB14MX31S125	MPB	5.439	5.329	6.110	6F-1	3.438		4.57	5.29	6.50	0.89	5.61		2.81	32.0
32	PB14MX32S125	MPB	5.614	5.504	6.110	6F-1	3.438		4.57	5.29	6.50	0.89	5.61		2.81	34.0
33	PB14MX33S125	MPB	5.790	5.680	6.470	6F-1	3.500		4.89	5.29	6.69	1.08	5.61		2.81	31.8
34	PB14MX34S125	MPB	5.965	5.855	6.470	6F-1	3.500		4.89	5.29	6.69	1.08	5.61		2.81	34.3
35	PB14MX35S125	MPB	6.141	6.031	6.820	6F-1	3.813		5.30	5.29	6.69	1.08	5.61		2.81	36.2
36	PB14MX36S125	MPB	6.316	6.206	6.820	6F-1	3.813		5.30	5.29	6.69	1.08	5.61		2.81	38.0
37	PB14MX37S125	MPB	6.492	6.382	7.170	6F-1	4.125		5.63	5.29	6.69	1.08	5.61		2.81	40.3
38	PB14MX38S125	MPB	6.667	6.557	7.170	6F-1	4.125		5.63	5.29	6.69	1.08	5.61		2.81	42.5
39	PB14MX39S125	MPB	6.842	6.732	7.520	6F-1	4.375		5.89	5.29	6.69	1.08	5.61		2.81	44.9
40	PB14MX40S125	MPB	7.018	6.908	7.520	6F-1	4.375		5.89	5.29	6.69	1.08	5.61		2.81	47.2
43	PB14MX43S125	MPB	7.543	7.434	8.040	6F-1	4.813		6.510	5.29	6.81	1.20	5.61		2.81	55.5
45	PB14MX45S125	MPB	7.894	7.785	8.400	6F-1	5.000		6.760	5.29	6.81	1.20	5.61		2.81	61.3
48	PB14MX48S125	MPB	8.421	8.311	8.940	6F-1	5.625		7.290	5.29	6.81	1.20	5.61		2.81	68.7
Taper Bushed 14mm Pitch, 125mm (4.92 in.) Wide Belt (14M-125)																
50	14MX50S125-4535	4535	8.772	8.662	9.290	AF-1	4.500	7.44		5.29	3.50		5.61		2.81	39.4
53	14MX53S125-4535	4535	9.299	9.189	9.690	AF-1	4.500	7.83		5.29	3.50		5.61		2.81	50.1
56	14MX56S125-4535	4535	9.825	9.715	10.360	AF-1	4.500	8.35		5.29	3.50		5.61		2.81	52.6
60	14MX60S125-4535	4535	10.527	10.417	11.070	AF-1	4.500	9.06		5.29	3.50		5.61		2.81	63.3
63	14MX63S125-4535	4535	11.053	10.943	11.590	AF-1	4.500	9.59		5.29	3.50		5.61		2.81	77.2
67	14MX67S125-4535	4535	11.755	11.645	12.500	AF-1	4.500	9.88		5.29	3.50		5.61		2.81	93.8
71	14MX71S125-5040	5040	12.457	12.347	13.070	AF-1	5.000	10.67		5.29	4.00		5.61		2.81	93.0
75	14MX75S125-5040	5040	13.158	13.048	13.730	AF-1	5.000	11.63		5.29	4.00		5.61		2.81	132.8
80	14MX80S125-5040	5040	14.036	13.926	14.620	AF-1	5.000	12.59		5.29	4.00		5.61		2.81	137.0
90	14MX90S125-5040	5040	15.790	15.680		D-1	5.000	14.26	11.00		4.00		5.61	1.61	2.81	121.0
112	14MX112S125-6050	6050	19.650	19.540		A-1	6.000	16.35			5.00		5.61	0.61	2.81	210.6
140	14MX140S125-6050	6050	24.562	24.452		D-3	6.000	20.74	15.50		5.00		5.61	0.61	2.81	270.3
168	14MX168S125-7060	7060	29.475	29.365		C-3	7.000	25.11	17.00		6.00		5.61	0.39	2.81	345.2
180	14MX180S125-7060	7060	31.580	31.470		C-3	7.000	27.06	17.00		6.00		5.61	0.39	2.81	365.2
200	14MX200S125-7060	7060	35.089	34.979		C-3	7.000	30.29	17.00		6.00		5.61	0.39	2.81	373.5
224	14MX224S125-7060	7060	39.300	39.190		C-3	7.000	34.21	17.00		6.00		5.61	0.39	2.81	482.3

Type: 1 - Solid 2 - Web 3 - Arms F=Flanged
 NOTE: Weights for Minimum Plain Bore (MPB) Sprockets are with minimum bore.
 Weights for Bushed Sprockets less bushing.

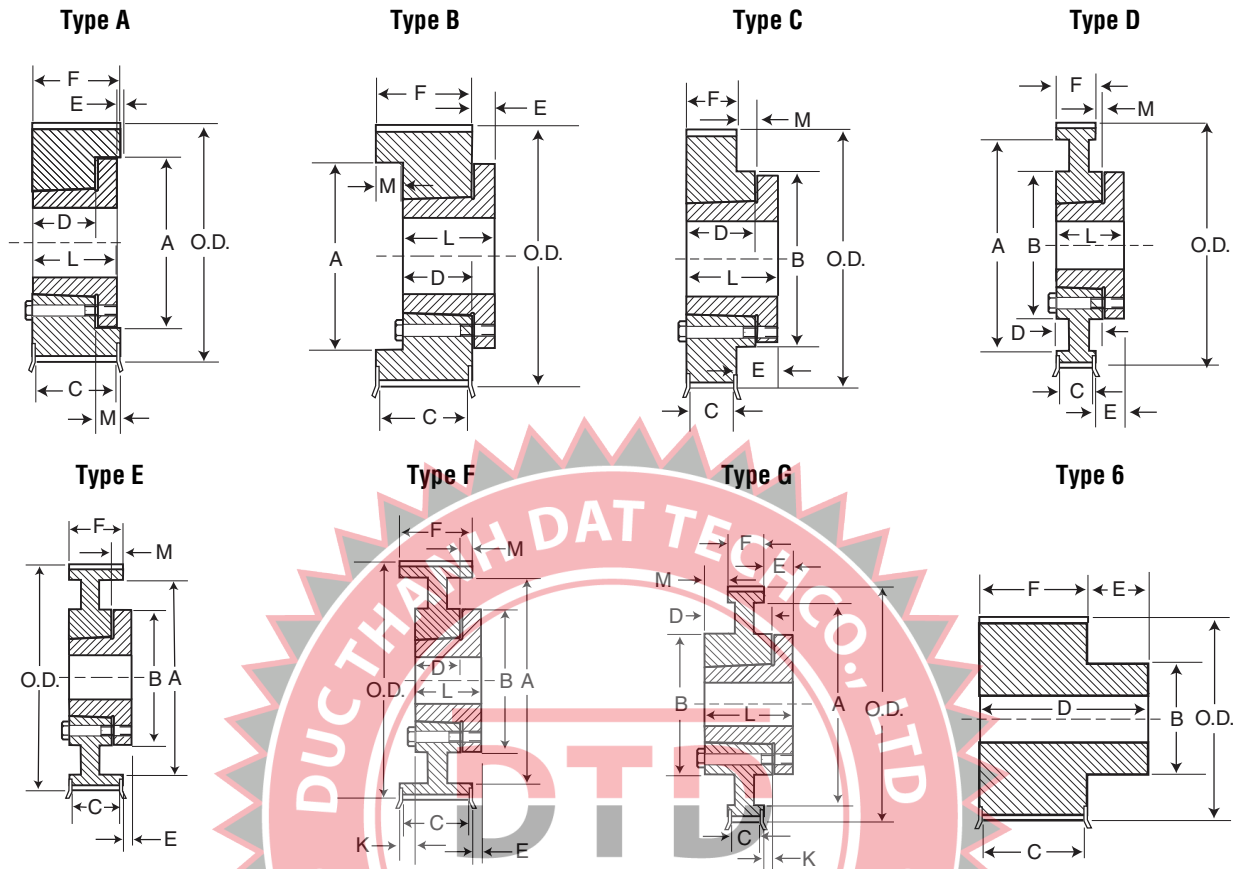

14mm Pitch — 20mm Wide Air Cool Heat Exchange Belt

No. of Teeth	Catalog Number	Bore	Pitch Diameter	Diameter (in)		Type	Max. Bore	Dimensions (in)									Weight Approx. (lbs.)
				O.D.	Max. Flange O.D.			A	B	C	D	E	F	L	M	F-CL	
MPB 14mm Pitch, 20mm (0.787 in.) Wide Belt (14M-20)																	
28	F14MX28S20-SK	SK	4.912	4.802	5.402	AF-1	2.625	3.61		1.04	1.25	0.45	1.36	1.94	0.11	0.68	3.90
29	F14MX29S20-SK	SK	5.088	4.978	5.763	AF-1	2.625	3.85		1.04	1.25	0.45	1.36	1.94	0.11	0.68	4.50
30	F14MX30S20-SK	SK	5.263	5.153	5.763	AF-1	2.625	3.99		1.04	1.25	0.45	1.36	1.94	0.11	0.68	4.80
31	F14MX31S20-SK	SK	5.439	5.329	6.114	AF-1	2.625	4.20		1.04	1.25	0.45	1.36	1.94	0.11	0.68	5.50
32	F14MX32S20-SK	SK	5.614	5.504	6.114	AF-1	2.625	4.22		1.04	1.25	0.45	1.36	1.94	0.11	0.68	5.9
33	F14MX33S20-SK	SK	5.79	5.680	6.465	AF-1	2.625	4.53		1.04	1.25	0.45	1.36	1.94	0.11	0.68	6.3
34	F14MX34S20-SK	SK	5.965	5.855	6.465	AF-1	2.625	4.53		1.04	1.25	0.45	1.36	1.94	0.11	0.68	6.9
35	F14MX35S20-SK	SK	6.141	6.031	6.816	AF-1	2.625	4.89		1.04	1.25	0.45	1.36	1.94	0.11	0.68	7.3
140	F14MX140S20-E	E	24.560	24.452		C-3	3.500	23.21	7.50	1.04	1.63	1.15	1.36	2.75	0.27	0.68	66.10
168	F14MX168S20-F	F	29.472	29.365		G-3	4.000	27.46	7.25	1.04	2.50	1.58	1.36	3.75	0.56	0.68	90.00
180	F14MX180S20-F	F	31.580	31.470		C-3	4.000	29.38	7.25	1.04	2.50	2.14	1.36	3.75	1.14	0.68	107.30
200	F14MX200S20-F	F	35.086	34.98		G-3	4.000	32.88	7.25	1.04	2.5	1.26	1.36	3.75	0.88	0.68	119.00
224	F14MX224S20-F	F	39.300	39.190		C-3	4.000	37.13	7.25	1.04	2.50	1.15	1.36	3.75	1.14	0.68	125.00

Type: 1- Solid 2- Web 3- Arms F=Flanged

NOTE: Weights for Minimum Plain Bore (MPB) Sprockets are with minimum bore.
Weights for Bushed Sprockets less bushing.

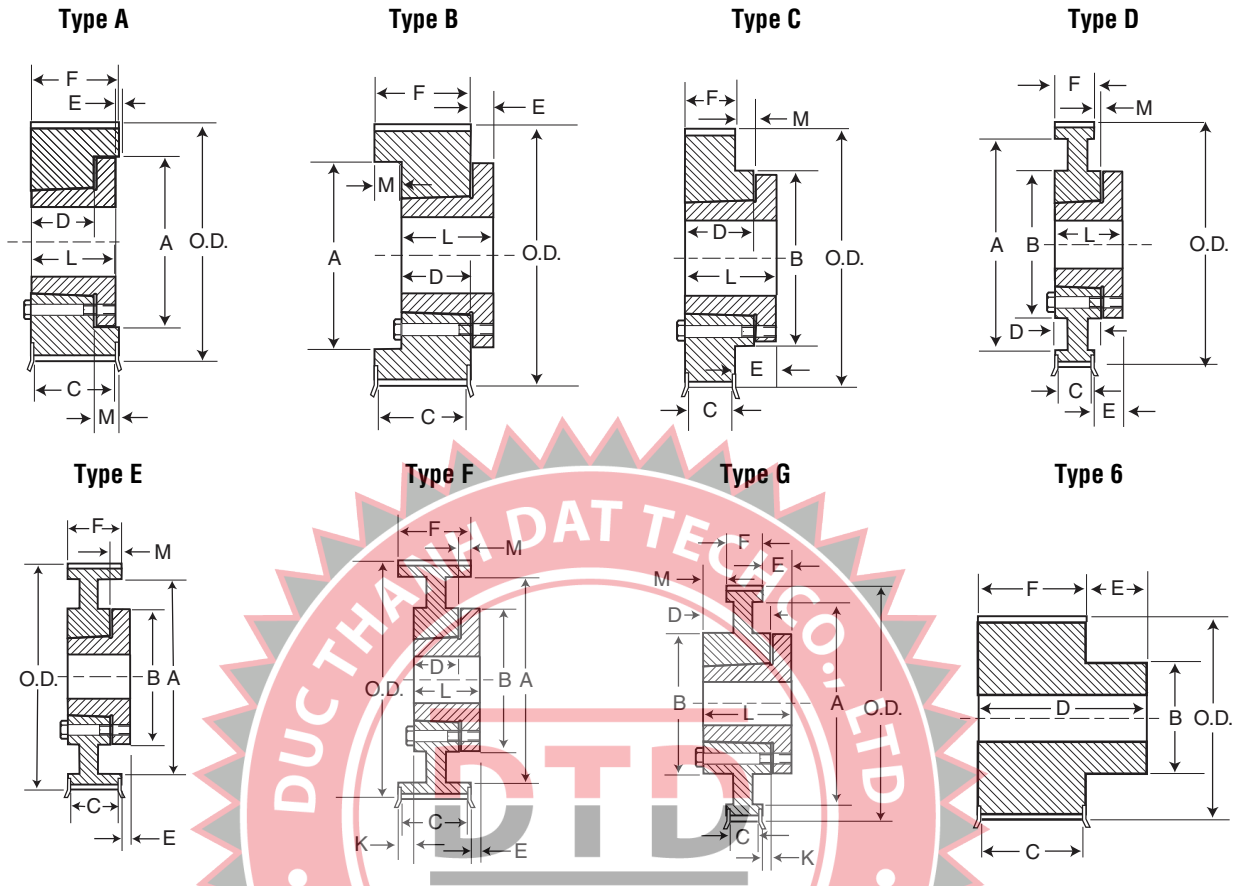

14mm Pitch — 37mm Wide Air Cool Heat Exchange Belt

No. of Teeth	Catalog Number	Bore	Pitch Diameter	Diameter (in.)		Type	Max. Bore	Dimensions (in.)								Weight Approx. (lbs.)	
				O.D.	Max. Flange O.D.			A	B	C	D	E	F	L	M		F-CL
MPB 14mm Pitch, 20mm (0.787 in.) Wide Belt (14M-20)																	
28	F14MX28S37-SK	SK	4.912	4.802	5.402	BF-1	2.625	3.61	1.74	1.25	0.56	2.06	1.94	0.81	1.03	4.20	
29	F14MX29S37-SK	SK	5.088	4.978	5.763	BF-1	2.625	3.75	1.74	1.25	0.56	2.06	1.94	0.81	1.03	4.70	
30	F14MX30S37-SK	SK	5.263	5.153	5.763	BF-1	2.625	3.89	1.74	1.25	0.56	2.06	1.94	0.81	1.03	5.00	
31	F14MX31S37-SK	SK	5.439	5.329	6.114	AF-1	2.625	4.06	1.74	1.25	-0.25	2.06	1.94	0.81	1.03	6.00	
32	F14MX32S37-SK	SK	5.614	5.504	6.114	AF-1	2.625	4.22	1.74	1.25	-0.25	2.06	1.94	0.81	1.03	7.10	
33	F14MX33S37-SK	SK	5.79	5.680	6.465	AF-1	2.625	4.41	1.74	1.25	-0.25	2.06	1.94	0.81	1.03	7.50	
34	F14MX34S37-SK	SK	5.965	5.855	6.465	AF-1	2.625	4.53	1.74	1.25	-0.25	2.06	1.94	0.81	1.03	7.80	
35	F14MX35S37-SK	SK	6.141	6.031	6.816	AF-1	2.625	4.75	1.74	1.25	-0.25	2.06	1.94	0.81	1.03	8.30	
36	F14MX36S37-SF	SF	6.315	6.206	6.816	AF-1	2.813	4.94	1.74	1.50	-0.19	2.06	2.06	0.56	1.03	8.80	
180	F14MX180S37-E	E	31.580	31.470		D-3	3.500	29.38	7.50		1.63	0.69	2.03	2.75	0.21	1.02	120.0
200	F14MX200S37-E	E	35.086	34.980		D-3	3.500	32.92	7.50		1.63	0.69	2.03	2.75	0.21	1.02	130.0
224	F14MX224S37-E	E	39.300	39.190		D-3	3.500	37.13	7.50		1.63	0.69	2.03	2.75	0.21	1.02	177.0

Type: 1- Solid 2- Web 3- Arms F=Flanged

NOTE: Weights for Minimum Plain Bore (MPB) Sprockets are with minimum bore.

Weights for Bushed Sprockets less bushing.

Sheave Nomenclature

Martin V-belt sheaves meet the toughest demands of industry, while continuing the *Martin* tradition of providing the utmost in service and maintaining unsurpassed manufacturing standards.

Totally committed to meeting the individual needs of customers, *Martin* Sprocket & Gear now serves the V-belt industry with extensive stock inventories, the capacity to meet large quantity requirements and the versatility to respond quickly to made-to-order applications.

NOMENCLATURE

QD

HI-CAP® WEDGE (Also Referred To As "Narrow")	CONVENTIONAL (Also Referred To As "Classical")
2-3V-220-JA	12-D-580-P
2 — Number of Grooves 3V — Belt Cross Section 220 — 2.2" <i>Outside Diameter</i> JA — Bushing Required	12 — Number of Grooves D — Belt Cross Section 580 — 58.0" <i>Pitch Diameter</i> P — Bushing Required

TAPER BUSHED

HI-CAP® WEDGE (Also Referred To As "Narrow")	CONVENTIONAL (Also Referred To As "Classical")
10-8V-5300-TB	1-B-34-TB
10 — Number of Grooves 8V — Belt Cross Section 5300 — 53.00" <i>Outside Diameter</i> TB — Taper Bushing Required	1 — Number of Grooves B — Belt Cross Section 34 — 3.4" <i>Pitch Diameter</i> (B-Belt) TB — Taper Bushing Required

MST

HI-CAP® WEDGE (Also Referred To As "Narrow")	CONVENTIONAL (Also Referred To As "Classical")
6-5V-925-R	3-C-110-Q
6 — Number of Grooves 5V — Belt Cross Section 925 — 9.25" <i>Outside Diameter</i> R — Taper Bushing Required	3 — Number of Grooves C — Belt Cross Section 110 — 11.0" <i>Pitch Diameter</i> (B-Belt) Q — Taper Bushing Required

PLEASE NOTE:

Dashes are **REQUIRED** in place of spaces when ordering or searching on PTplace.com.

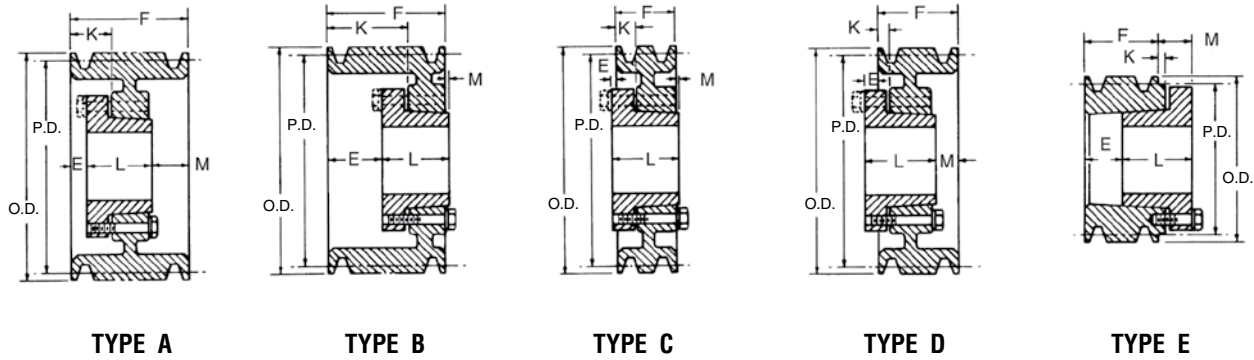

Dimensions for *Martin* sheaves are listed in the following tables with QD bushings in place. The type of sheave shown below is indicated by a letter, and the construction is indicated by a number, as shown on facing page.

QD Sheaves — 3V

Nomenclature Example: 1-3V-220-JA

1 Groove* F = 1/16"											2 Groove F = 1/32"										
Part Number	OD	PD 3V Belt	Type	Bush	Bush Max. Bore	E ☆	K	L Length Thru Bore	M ☆	Wt. Less Bush	Part Number	Type	Bush	Bush Max. Bore	E ☆	K	L Length Thru Bore	M ☆	Wt. Less Bush		
																				1 3V 220 JA	2.20
1 3V 235 JA	2.35	2.30	E-1	JA	1 1/4	3/16	7/16	1 1/8	1/16	.8	2 3V 235 JA	E-1	JA	1 1/4	3/16	7/16	1 1/8	1/16	1.0		
1 3V 250 JA	2.50	2.45	E-1	JA	1 1/4	3/16	7/16	1 1/8	1/16	.8	2 3V 250 JA	E-1	JA	1 1/4	3/16	7/16	1 1/8	1/16	1.2		
1 3V 265 JA	2.65	2.60	C-1	JA	1 1/4	3/8	1/2	1 1/8	0	.9	2 3V 265 JA	D-1	JA	1 1/4	3/8	1/2	1 1/8	1/16	1.3		
1 3V 280 JA	2.80	2.75	C-1	JA	1 1/4	3/8	1/2	1 1/8	0	.9	2 3V 280 JA	D-1	JA	1 1/4	3/8	1/2	1 1/8	1/16	1.4		
1 3V 300 JA	3.00	2.95	C-1	JA	1 1/4	3/8	1/2	1 1/8	0	1.0	2 3V 300 JA	D-1	JA	1 1/4	3/8	1/2	1 1/8	1/16	1.6		
1 3V 315 JA	3.15	3.10	C-1	JA	1 1/4	3/8	1/2	1 1/8	0	1.0	2 3V 315 JA	D-1	JA	1 1/4	3/8	1/2	1 1/8	1/16	1.8		
1 3V 335 JA	3.35	3.30	C-1	JA	1 1/4	3/8	1/2	1 1/8	0	1.1	2 3V 335 SH	D-1	SH	1 1/4	7/16	5/8	1 1/8	1/16	2.0		
1 3V 365 SH	3.65	3.60	D-1	SH	1 1/4	3/8	0	1 1/8	1/16	1.3	2 3V 365 SH	D-1	SH	1 1/4	7/16	5/8	1 1/8	1/16	2.4		
1 3V 412 SH	4.12	4.07	D-1	SH	1 1/4	3/8	0	1 1/8	1/16	1.7	2 3V 412 SH	D-1	SH	1 1/4	7/16	5/8	1 1/8	1/16	2.7		
1 3V 450 SH	4.50	4.45	D-2	SH	1 1/4	3/8	0	1 1/8	1/16	2.1	2 3V 450 SH	D-1	SH	1 1/4	7/16	5/8	1 1/8	1/16	2.9		
1 3V 475 SH	4.75	4.70	D-2	SH	1 1/4	3/8	0	1 1/8	1/16	2.5	2 3V 475 SH	D-1	SH	1 1/4	7/16	5/8	1 1/8	1/16	3.1		
1 3V 500 SH	5.00	4.95	D-2	SH	1 1/4	3/8	0	1 1/8	1/16	2.8	2 3V 500 SH	D-1	SH	1 1/4	7/16	5/8	1 1/8	1/16	3.6		
1 3V 530 SH	5.30	5.25	D-2	SH	1 1/4	3/8	0	1 1/8	1/16	3.2	2 3V 530 SH	D-1	SH	1 1/4	7/16	5/8	1 1/8	1/16	4.5		
1 3V 560 SH	5.60	5.55	D-2	SH	1 1/4	3/8	0	1 1/8	1/16	3.2	2 3V 560 SH	D-1	SH	1 1/4	7/16	5/8	1 1/8	1/16	5.0		
1 3V 600 SH	6.00	5.95	D-2	SH	1 1/4	3/8	0	1 1/8	1/16	3.5	2 3V 600 SH	D-1	SH	1 1/4	7/16	5/8	1 1/8	1/16	5.5		
1 3V 650 SH	6.50	6.45	D-3	SH	1 1/4	3/8	0	1 1/8	1/16	3.9	2 3V 650 SDS	D-3	SDS	2	3/16	5/8	1 1/8	1/16	5.8		
1 3V 690 SH	6.90	6.85	D-3	SH	1 1/4	3/8	0	1 1/8	1/16	4.5	2 3V 690 SDS	D-3	SDS	2	3/16	5/8	1 1/8	1/16	6.6		
1 3V 800 SDS	8.00	7.95	C-3	SDS	2	3/8	0	1 1/8	0	5.5	2 3V 800 SDS	D-3	SDS	2	3/16	5/8	1 1/8	1/16	7.0		
1 3V 1060 SDS	10.60	10.55	C-3	SDS	2	3/8	0	1 1/8	0	8.0	2 3V 1060 SK	C-3	SK	2 3/8	7/16	1 1/2	2 1/8	1/16	10.0		
1 3V 1400 SK	14.00	13.95	C-3	SK	2 3/8	7/16	0	1 1/8	0	13.5	2 3V 1400 SK	C-3	SK	2 3/8	7/16	1 1/2	2 1/8	1/16	16.0		
1 3V 1900 SK	19.00	18.95	C-3	SK	2 3/8	7/16	0	1 1/8	0	17.0	2 3V 1900 SK	C-3	SK	2 3/8	7/16	1 1/2	2 1/8	1/16	25.0		
											2 3V 2500 SF	C-3	SF	2 3/8	7/16	1 1/2	2 1/8	1/16	28.0		

NOTE: Dimensions in inches, weight in pounds. Weights do not include bushings. See page B-3 and B-4 for additional bushing dimensions.

* F = 3/8" for 1 3V 800 SDS and 1 3V 1060 SDS, F = 1/16" for 1 3V 1400 SK and 1 3V 1900 SK

☆ E and M dimensions are nominal and will vary depending on shaft tolerances. Type E sheaves are drilled for reverse mounting only.

PLEASE NOTE: Dashes are REQUIRED in place of spaces when ordering or searching on PTplace.com.

Every effort is made to keep all catalog dimensions and styles current in the catalog. However, from time to time it is necessary because of manufacturing changes to alter stock products dimensionally. If any stock product dimension or style in this catalog section is critical to your application please contact *Martin* for certification.

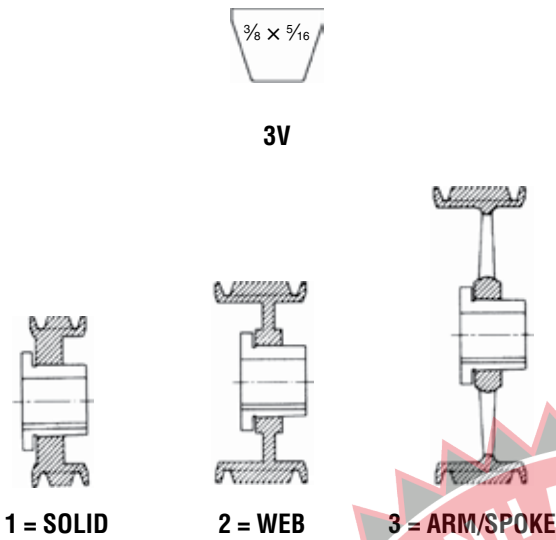

Let *Martin* quote your made to order and large quantity requirements.

QD Sheaves — 3V

Nomenclature Example: **3-3V-250-JA**

3 Groove F = 1½											4 Groove F = 1¾							
Part Number	OD	PD 3V Belt	Type	Bush Max. Bore	E ☆	K	L Length Thru Bore	M ☆	Wt. Less Bush	Part Number	Type	Bush Max. Bore	E ☆	K	L Length Thru Bore	M ☆	Wt. Less Bush	
3 3V 250 JA	2.50	2.45	E-1	JA	1¼	1¾	7/16	1¼	19/16	1.6								
3 3V 265 JA	2.65	2.60	D-1	JA	1¼	¾	1/8	1¼	19/16	1.8	4 3V 265 JA	D-1	JA	1¼	¾	1¼	1½	1.3
3 3V 280 JA	2.80	2.75	D-1	JA	1¼	¾	1/8	1¼	19/16	2.0	4 3V 280 JA	D-1	JA	1¼	¾	1¼	1½	1.6
3 3V 300 SH	3.00	2.95	E-1	SH	1½	1¼	0	1½	9/16	2.2	4 3V 300 SH	E-1	SH	1½	1½	1½	¾	1.9
3 3V 315 SH	3.15	3.10	E-1	SH	1½	1¼	5/16	1½	7/8	2.5	4 3V 315 SH	E-1	SH	1½	1½	1½	¾	2.2
3 3V 335 SH	3.35	3.30	D-1	SH	1½	7/16	1/8	1½	9/16	2.8	4 3V 335 SH	D-1	SH	1½	7/16	1½	1½	2.5
3 3V 365 SH	3.65	3.60	D-1	SH	1½	7/16	1/8	1½	9/16	3.0	4 3V 365 SH	D-1	SH	1½	7/16	1½	1½	2.8
3 3V 412 SH	4.12	4.07	A-1	SH	1½	¾	1/8	1½	7/16	3.3	4 3V 412 SH	A-1	SH	1½	¾	1½	1½	3.2
3 3V 450 SDS	4.50	4.45	A-1	SDS	2	¾	1/8	1½	7/16	3.5	4 3V 450 SDS	A-1	SDS	2	¾	1½	1½	3.5
3 3V 475 SDS	4.75	4.70	A-1	SDS	2	¾	1/8	1½	7/16	3.7	4 3V 475 SDS	A-1	SDS	2	¾	1½	1½	4.0
3 3V 500 SDS	5.00	4.95	A-1	SDS	2	¾	1/8	1½	7/16	4.0	4 3V 500 SDS	A-1	SDS	2	¾	1½	1½	4.5
3 3V 530 SDS	5.30	5.25	A-1	SDS	2	¾	1/8	1½	7/16	4.3	4 3V 530 SDS	A-1	SDS	2	¾	1½	1½	5.0
3 3V 560 SDS	5.60	5.55	A-1	SDS	2	¾	1/8	1½	7/16	4.9	4 3V 560 SDS	A-1	SDS	2	¾	1½	1½	5.7
3 3V 600 SDS	6.00	5.95	A-1	SDS	2	¾	1/8	1½	7/16	5.9	4 3V 600 SK	D-1	SK	2½	7/16	¾	1½	7.5
3 3V 650 SDS	6.50	6.45	A-3	SDS	2	¾	1/8	1½	7/16	6.3	4 3V 650 SK	A-1	SK	2½	7/16	¾	1½	8.0
3 3V 690 SDS	6.90	6.85	A-3	SDS	2	¾	1/8	1½	7/16	6.8	4 3V 690 SK	A-1	SK	2½	7/16	¾	1½	10.0
3 3V 800 SK	8.00	7.95	C-2	SK	2½	7/16	1/4	1½	0	10.6	4 3V 800 SK	D-2	SK	2½	7/16	¾	1½	12.0
3 3V 1060 SK	10.60	10.55	C-3	SK	2½	7/16	1/4	1½	0	12.0	4 3V 1060 SK	D-3	SK	2½	7/16	¾	1½	16.0
3 3V 1400 SK	14.00	13.95	C-3	SK	2½	7/16	1/4	1½	0	20.0	4 3V 1400 SK	D-3	SK	2½	7/16	¾	1½	22.0
3 3V 1900 SF	19.00	18.95	C-3	SF	2½	7/16	1/4	2½	¾	33.0	4 3V 1900 SF	C-3	SF	2½	7/16	¾	2½	37.0
3 3V 2500 SF	25.00	24.95	C-3	SF	2½	7/16	1/4	2½	¾	45.0	4 3V 2500 SF	C-3	SF	2½	7/16	¾	2½	53.0
3 3V 3350 SF	33.50	33.45	C-3	SF	2½	7/16	1/4	2½	¾	75.0	4 3V 3350 E	C-3	E	3½	¾	1/2	2½	80.0

NOTE: Dimensions in inches, weight in pounds. Weights do not include bushings. See page B-3 and B-4 for additional bushing dimensions.
 ☆ E and M dimensions are nominal and will vary depending on shaft tolerances. Type E sheaves are drilled for reverse mounting only.

PLEASE NOTE: Dashes are REQUIRED in place of spaces when ordering or searching on PTplace.com.

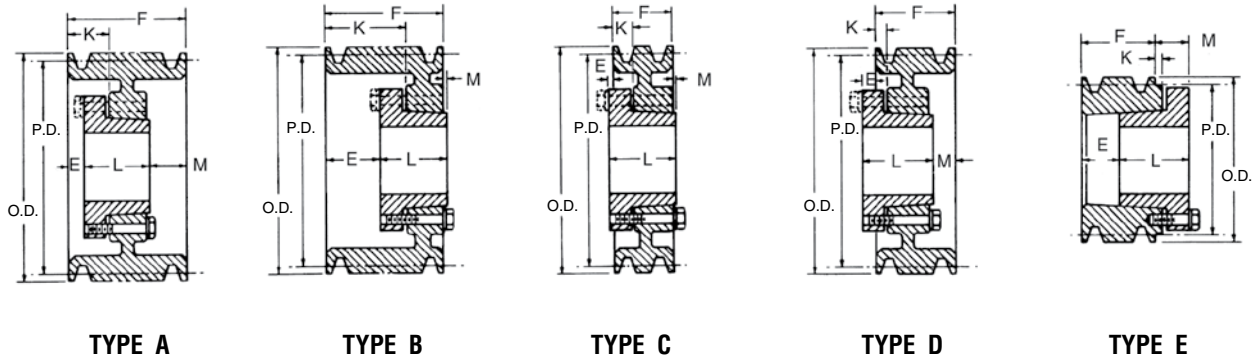

QD Sheaves — 3V

Nomenclature Example: 5-3V-475-SDS

5 Groove F = 2 ⁵ / ₁₆											6 Groove F = 2 ²³ / ₃₂										
Part Number	OD	PD 3V Belt	Type	Bush	Bush Max. Bore	E ☆	K	L Length Thru Bore	M ☆	Wt. Less Bush	Part Number	Type	Bush	Bush Max. Bore	E ☆	K	L Length Thru Bore	M ☆	Wt. Less Bush		
5 3V 475 SDS	4.75	4.70	A-2	SDS	2	3/16	1/8	1 1/8	3/8	4.5	6 3V 475 SK	D-1	SK	2 1/2	3/16	1/8	1 1/8	1 1/2	6.0		
5 3V 500 SDS	5.00	4.95	A-2	SDS	2	3/16	1/8	1 1/8	3/8	5.3	6 3V 500 SK	D-1	SK	2 1/2	3/16	1/8	1 1/8	1 1/2	6.5		
5 3V 530 SK	5.30	5.25	A-1	SK	2 1/2	1/4	1 1/8	1 1/8	1/2	5.8	6 3V 530 SK	A-1	SK	2 1/2	3/8	1 1/8	1 1/8	3/2	6.8		
5 3V 560 SK	5.60	5.55	A-1	SK	2 1/2	1/4	1 1/8	1 1/8	1/2	7.0	6 3V 560 SK	A-1	SK	2 1/2	3/8	1 1/8	1 1/8	3/2	8.0		
5 3V 600 SK	6.00	5.95	A-1	SK	2 1/2	1/4	1 1/8	1 1/8	1/2	8.3	6 3V 600 SK	A-1	SK	2 1/2	3/8	1 1/8	1 1/8	3/2	9.0		
5 3V 650 SK	6.50	6.45	A-1	SK	2 1/2	1/4	1 1/8	1 1/8	1/2	9.0	6 3V 650 SK	A-2	SK	2 1/2	3/8	1 1/8	1 1/8	3/2	10.0		
5 3V 690 SK	6.90	6.85	A-1	SK	2 1/2	1/4	1 1/8	1 1/8	1/2	12.0	6 3V 690 SK	A-2	SK	2 1/2	3/8	1 1/8	1 1/8	3/2	11.5		
5 3V 800 SK	8.00	7.95	A-2	SK	2 1/2	1/4	1 1/8	1 1/8	1/2	13.0	6 3V 800 SK	A-2	SK	2 1/2	3/8	1 1/8	1 1/8	3/2	17.0		
5 3V 1060 SK	10.60	10.55	A-3	SK	2 1/2	1/4	1 1/8	1 1/8	1/2	17.0	6 3V 1060 SF	A-2	SF	2 1/2	3/8	1 1/8	2 1/2	3/2	25.0		
5 3V 1400 SF	14.00	13.95	A-3	SK	2 1/2	3/8	1 1/2	2 1/2	1/2	27.0	6 3V 1400 SF	A-3	SF	2 1/2	3/8	1 1/8	2 1/2	3/2	34.0		
5 3V 1900 SF	19.00	18.95	A-3	SK	2 1/2	3/8	1 1/2	2 1/2	1/2	40.0	6 3V 1900 E	B-3	E	3 1/2	1/2	1	2 1/2	1/2	45.0		
5 3V 2500 E	25.00	24.95	C-3	E	3 1/2	1/4	1 1/2	2 1/2	1/2	69.0	6 3V 2500 E	B-3	E	3 1/2	1/2	1	2 1/2	1/2	75.0		
5 3V 3350 E	33.50	33.45	C-3	E	3 1/2	1/4	1 1/2	2 1/2	1/2	97.0	6 3V 3350 E	B-3	E	3 1/2	1/2	1	2 1/2	1/2	98.0		

NOTE: Dimensions in inches, weight in pounds. Weights do not include bushings. See page B-3 and B-4 for additional bushing dimensions.
 ☆ E and M dimensions are nominal and will vary depending on shaft tolerances. Type E sheaves are drilled for reverse mounting only.

QD Sheaves — 3V

Nomenclature Example: 8-3V-475-SK

8 Groove F = 3 ¹⁷ / ₃₂											10 Groove F = 4 ¹¹ / ₃₂										
Part Number	OD	PD 3V Belt	Type	Bush	Bush Max. Bore	E ☆	K	L Length Thru Bore	M ☆	Wt. Less Bush	Part Number	Type	Bush	Bush Max. Bore	E ☆	K	L Length Thru Bore	M ☆	Wt. Less Bush		
8 3V 475 SK	4.75	4.70	D-1	SK	2 1/2	3/16	1/8	1 1/8	2 3/2	6.0	10 3V 475 SK	D-1	SK	2 1/2	3/16	1/8	1 1/8	2 3/2	7.0		
8 3V 500 SK	5.00	4.95	D-1	SK	2 1/2	3/16	1/8	1 1/8	2 3/2	6.9	10 3V 500 SK	D-1	SK	2 1/2	3/16	1/8	1 1/8	2 3/2	8.6		
8 3V 530 SK	5.30	5.25	A-1	SK	2 1/2	3/8	1 1/8	1 1/8	3/2	7.8	10 3V 530 SK	A-1	SK	2 1/2	3/8	1 1/8	1 1/8	3 1/2	9.0		
8 3V 560 SK	5.60	5.55	A-1	SK	2 1/2	3/8	1 1/8	1 1/8	3/2	9.0	10 3V 560 SK	A-1	SK	2 1/2	3/8	1 1/8	1 1/8	3 1/2	10.0		
8 3V 600 SK	6.00	5.95	A-1	SK	2 1/2	3/8	1 1/8	1 1/8	3/2	10.0	10 3V 600 SK	A-1	SK	2 1/2	3/8	1 1/8	1 1/8	3 1/2	11.0		
8 3V 650 SK	6.50	6.45	A-2	SK	2 1/2	3/8	1 1/8	1 1/8	3/2	12.9	10 3V 650 SK	A-2	SK	2 1/2	3/8	1 1/8	1 1/8	3 1/2	14.0		
8 3V 690 SK	6.90	6.85	A-2	SK	2 1/2	3/8	1 1/8	1 1/8	3/2	14.0	10 3V 690 SK	A-2	SK	2 1/2	3/8	1 1/8	1 1/8	3 1/2	16.0		
8 3V 800 SF	8.00	7.95	A-1	SF	2 1/2	7/16	1 1/2	2 1/2	1 1/2	20.0	10 3V 800 SF	A-1	SF	2 1/2	3/8	1 1/2	2 1/2	1 1/2	22.0		
8 3V 1060 SF	10.60	10.55	A-2	SF	2 1/2	7/16	1 1/2	2 1/2	1 1/2	28.0	10 3V 1060 E	A-2	E	3 1/2	3/8	1 1/2	2 1/2	1 1/2	33.0		
8 3V 1400 E	14.00	13.95	A-3	E	3 1/2	3/8	1 1/2	2 1/2	1 1/2	40.0	10 3V 1400 E	A-3	E	3 1/2	3/8	1 1/2	2 1/2	1 1/2	43.0		
8 3V 1900 E	19.00	18.95	A-3	E	3 1/2	3/8	1 1/2	2 1/2	1 1/2	62.0	10 3V 1900 E	A-3	E	3 1/2	3/8	1 1/2	2 1/2	1 1/2	66.0		
8 3V 2500 E	25.00	24.95	A-3	E	3 1/2	3/8	1 1/2	2 1/2	1 1/2	87.0	10 3V 2500 F	A-3	F	3 1/2	3/8	1 1/2	3 1/2	3/2	98.0		
8 3V 3350 F	33.50	33.45	B-3	F	3 1/2	3/8	1 1/2	3 1/2	3/2	152.0	10 3V 3350 F	A-3	F	3 1/2	3/8	1 1/2	3 1/2	3/2	178.0		

NOTE: Dimensions in inches, weight in pounds. Weights do not include bushings. See page B-3 and B-4 for additional bushing dimensions.
 ☆ E and M dimensions are nominal and will vary depending on shaft tolerances. Type E sheaves are drilled for reverse mounting only.

PLEASE NOTE: Dashes are REQUIRED in place of spaces when ordering or searching on PTplace.com.

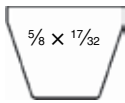

5V

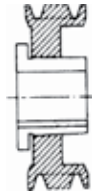

1 = SOLID

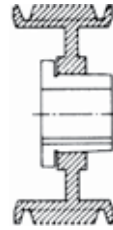

2 = WEB

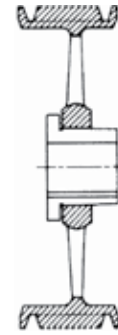

3 = ARM/SPOKE

QD Sheaves — 5V

Nomenclature Example: **2-5V-440-SH**

2 Groove F = 1 ¹¹ / ₁₆											3 Groove F = 2%								
Part Number	OD	PD Belt	Type	Bush	Bush Max. Bore	E ☆	K	L Length Thru Bore	M ☆	Wt. Less Bush	Part Number	Type	Bush	Bush Max. Bore	E ☆	K	L Length Thru Bore	M ☆	Wt. Less Bush
2 5V 440 SH	4.40	4.30	A-1	SH	1 ¹¹ / ₁₆	5/8	0	1 ¹ / ₁₆	1/8	4.0	3 5V 440 SDS	E-1	SDS	2	1%	0	1%	5/8	5.5
2 5V 465 SDS	4.65	4.55	E-1	SDS	2	1 ¹ / ₁₆	0	1 ¹ / ₁₆	5/8	4.5	3 5V 465 SDS	E-1	SDS	2	1%	0	1%	5/8	6.5
2 5V 490 SDS	4.90	4.80	A-1	SDS	2	1 ¹ / ₁₆	1 ¹ / ₁₆	1%	1/4	5.0	3 5V 490 SDS	A-1	SDS	2	7/8	1 ¹ / ₁₆	1%	5/8	7.0
2 5V 520 SDS	5.20	5.10	A-1	SDS	2	1 ¹ / ₁₆	1 ¹ / ₁₆	1%	1/4	5.5	3 5V 520 SDS	A-1	SDS	2	7/8	1 ¹ / ₁₆	1%	5/8	7.5
2 5V 550 SDS	5.50	5.40	A-1	SDS	2	1 ¹ / ₁₆	1 ¹ / ₁₆	1%	1/4	6.0	3 5V 550 SDS	A-1	SDS	2	7/8	1 ¹ / ₁₆	1%	5/8	8.0
2 5V 590 SDS	5.90	5.80	A-1	SDS	2	1 ¹ / ₁₆	1 ¹ / ₁₆	1%	1/4	7.0	3 5V 590 SDS	A-1	SDS	2	7/8	1 ¹ / ₁₆	1%	5/8	8.5
2 5V 630 SK	6.30	6.20	C-1	SK	2%	1/4	3/8	1 ¹ / ₁₆	0	8.0	3 5V 630 SK	A-1	SK	2%	3/8	1 ¹ / ₁₆	1 ¹ / ₁₆	1/8	11.0
2 5V 670 SK	6.70	6.60	C-1	SK	2%	1/4	3/8	1 ¹ / ₁₆	0	10.0	3 5V 670 SK	A-1	SK	2%	3/8	1 ¹ / ₁₆	1 ¹ / ₁₆	1/8	11.5
2 5V 710 SK	7.10	7.00	C-1	SK	2%	1/4	3/8	1 ¹ / ₁₆	0	11.0	3 5V 710 SF	A-1	SF	2 ¹ / ₁₆	5/8	1	2 ¹ / ₁₆	0	13.0
2 5V 750 SK	7.50	7.40	C-1	SK	2%	1/4	3/8	1 ¹ / ₁₆	0	13.0	3 5V 750 SF	A-1	SF	2 ¹ / ₁₆	5/8	1	2 ¹ / ₁₆	0	14.0
2 5V 800 SK	8.00	7.90	C-1	SK	2%	1/4	3/8	1 ¹ / ₁₆	0	14.0	3 5V 800 SF	A-1	SF	2 ¹ / ₁₆	5/8	1	2 ¹ / ₁₆	0	15.0
2 5V 850 SK	8.50	8.40	C-1	SK	2%	1/4	3/8	1 ¹ / ₁₆	0	15.0	3 5V 850 SF	A-1	SF	2 ¹ / ₁₆	5/8	1	2 ¹ / ₁₆	0	16.0
2 5V 900 SK	9.00	8.90	C-2	SK	2%	1/4	3/8	1 ¹ / ₁₆	0	16.0	3 5V 900 SF	A-2	SF	2 ¹ / ₁₆	5/8	1	2 ¹ / ₁₆	0	17.0
2 5V 925 SK	9.25	9.15	C-2	SK	2%	1/4	3/8	1 ¹ / ₁₆	0	16.5	3 5V 925 SF	A-2	SF	2 ¹ / ₁₆	5/8	1	2 ¹ / ₁₆	0	18.0
2 5V 975 SK	9.75	9.65	C-3	SK	2%	1/4	3/8	1 ¹ / ₁₆	0	17.0	3 5V 975 SF	A-2	SF	2 ¹ / ₁₆	5/8	1	2 ¹ / ₁₆	0	19.0
2 5V 1030 SK	10.30	10.20	C-3	SK	2%	1/4	3/8	1 ¹ / ₁₆	0	18.0	3 5V 1030 SF	A-2	SF	2 ¹ / ₁₆	5/8	1	2 ¹ / ₁₆	0	22.0
2 5V 1090 SK	10.90	10.80	C-3	SK	2%	1/4	3/8	1 ¹ / ₁₆	0	19.0	3 5V 1090 SF	A-2	SF	2 ¹ / ₁₆	5/8	1	2 ¹ / ₁₆	0	25.0
2 5V 1130 SK	11.30	11.20	C-3	SK	2%	1/4	3/8	1 ¹ / ₁₆	0	19.5	3 5V 1130 SF	A-2	SF	2 ¹ / ₁₆	5/8	1	2 ¹ / ₁₆	0	25.0
2 5V 1180 SK	11.80	11.70	C-3	SK	2%	1/4	3/8	1 ¹ / ₁₆	0	20.0	3 5V 1180 SF	A-2	SF	2 ¹ / ₁₆	5/8	1	2 ¹ / ₁₆	0	29.0
2 5V 1250 SF	12.50	12.40	C-3	SF	2 ¹ / ₁₆	1/4	3/8	2 ¹ / ₁₆	1/8	25.0	3 5V 1250 E	C-2	E	3%	1/8	1	2%	1/8	32.0
2 5V 1320 SF	13.20	13.10	C-3	SF	2 ¹ / ₁₆	1/4	3/8	2 ¹ / ₁₆	1/8	27.0	3 5V 1320 E	C-3	E	3 ¹ / ₂	1/8	3/4	2%	1/8	38.0
2 5V 1400 SF	14.00	13.90	C-3	SF	2 ¹ / ₁₆	1/4	3/8	2 ¹ / ₁₆	1/8	28.0	3 5V 1400 E	C-3	E	3%	1/8	3/4	2%	1/8	43.0
2 5V 1500 SF	15.00	14.90	C-3	SF	2 ¹ / ₁₆	1/4	3/8	2 ¹ / ₁₆	1/8	30.0	3 5V 1500 E	C-3	E	3%	1/8	3/4	2%	1/8	44.0
2 5V 1600 SF	16.00	15.90	C-3	SF	2 ¹ / ₁₆	1/4	3/8	2 ¹ / ₁₆	1/8	34.0	3 5V 1600 E	C-3	E	3 ¹ / ₂	1/8	3/4	2%	1/8	46.0
2 5V 1870 SF	18.70	18.60	C-3	SF	2 ¹ / ₁₆	1/4	3/8	2 ¹ / ₁₆	1/8	49.0	3 5V 1870 E	C-3	E	3 ¹ / ₂	1/8	3/4	2%	1/8	60.0
2 5V 2120 SF	21.20	21.10	C-3	SF	2 ¹ / ₁₆	1/4	3/8	2 ¹ / ₁₆	1/8	50.0	3 5V 2120 E	C-3	E	3 ¹ / ₂	1/8	3/4	2%	1/8	68.0
2 5V 2360 E	23.60	23.50	C-3	E	3 ¹ / ₂	3/8	1/4	2%	5/8	72.0	3 5V 2360 E	C-3	E	3 ¹ / ₂	1/8	3/4	2%	1/8	80.0
2 5V 2800 E	28.00	27.90	C-3	E	3 ¹ / ₂	3/8	1/4	2%	5/8	80.0	3 5V 2800 E	C-3	E	3 ¹ / ₂	1/8	3/4	2%	1/8	92.0
	31.50	31.40									3 5V 3150 F	C-3	F	3 ¹ / ₂	3/8	3/4	3%	1 ¹ / ₁₆	136.0
	37.50	37.40									3 5V 3750 F	C-3	F	3 ¹ / ₂	3/8	3/4	3%	1 ¹ / ₁₆	156.0
	50.00	49.90									3 5V 5000 F	C-3	F	3 ¹ / ₂	3/8	3/4	3%	1 ¹ / ₁₆	210.0

NOTE: Dimensions in inches, weight in pounds. Weights do not include bushings. See page B-3 and B-4 for additional bushing dimensions.

☆ E and M dimensions are nominal and will vary depending on shaft tolerances. Type E sheaves are drilled for reverse mounting only.

PLEASE NOTE: Dashes are REQUIRED in place of spaces when ordering or searching on PTplace.com.

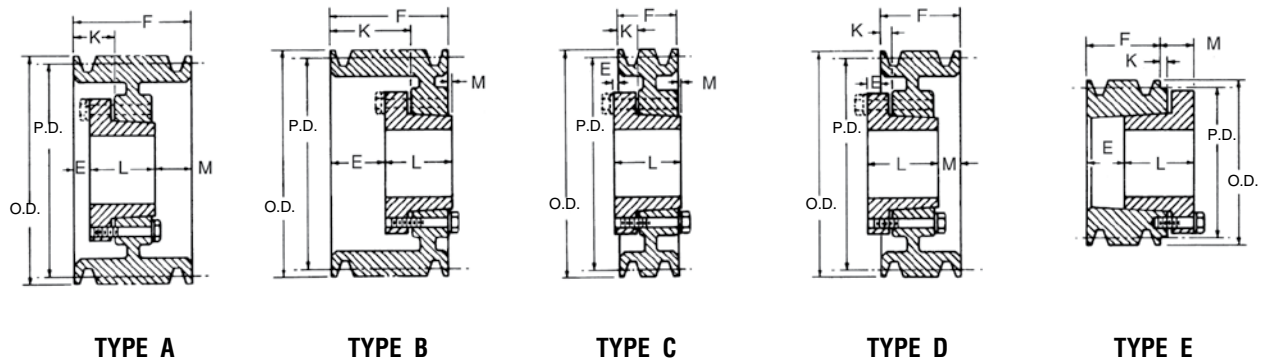

QD Sheaves — 5V

Nomenclature Example: 4-5V-440-SD

4 Groove F = 3 ¹ / ₁₆										5 Groove F = 3 ³ / ₁₆									
Part Number	OD	PD 5V Belt	Type	Bush	Bush Max. Bore	E ☆	K	L Length Thru Bore	M ☆	Wt. Less Bush	Part Number	Type	Bush	Bush Max. Bore	E ☆	K	L Length Thru Bore	M ☆	Wt. Less Bush
4 5V 440 SD	4.40	4.30	E-1	SD	2	1 ¹ / ₁₆	0	1 ¹ / ₁₆	%	5.0	5 5V 440 SD	E-1	SD	2	2 ³ / ₁₆	0	1 ¹ / ₁₆	%	6.0
4 5V 465 SD	4.65	4.55	E-1	SD	2	1 ¹ / ₁₆	0	1 ¹ / ₁₆	%	6.0	5 5V 465 SD	E-1	SD	2	2 ³ / ₁₆	1 ¹ / ₁₆	1 ¹ / ₁₆	%	7.0
4 5V 490 SD	4.90	4.80	A-1	SD	2	1 ¹ / ₁₆	1 ¹ / ₁₆	1 ¹ / ₁₆	%	7.0	5 5V 490 SD	A-1	SD	2	1 ¹ / ₁₆	1 ¹ / ₁₆	1 ¹ / ₁₆	1 ¹ / ₁₆	8.0
4 5V 520 SD	5.20	5.10	A-1	SD	2	1 ¹ / ₁₆	1 ¹ / ₁₆	1 ¹ / ₁₆	%	8.0	5 5V 520 SD	A-1	SD	2	1 ¹ / ₁₆	1 ¹ / ₁₆	1 ¹ / ₁₆	1 ¹ / ₁₆	9.0
4 5V 550 SD	5.50	5.40	A-1	SD	2	1 ¹ / ₁₆	1 ¹ / ₁₆	1 ¹ / ₁₆	%	9.0	5 5V 550 SD	A-1	SD	2	1 ¹ / ₁₆	1 ¹ / ₁₆	1 ¹ / ₁₆	1 ¹ / ₁₆	10.0
4 5V 590 SD	5.90	5.80	A-1	SD	2	1 ¹ / ₁₆	1 ¹ / ₁₆	1 ¹ / ₁₆	%	10.8	5 5V 590 SK	A-1	SK	2	%	1 ¹ / ₁₆	1 ¹ / ₁₆	1 ¹ / ₁₆	11.0
4 5V 630 SK	6.30	6.20	A-1	SK	2	%	1 ¹ / ₁₆	1 ¹ / ₁₆	1/2	12.0	5 5V 630 SK	A-1	SK	2	%	1 ¹ / ₁₆	1 ¹ / ₁₆	1 ¹ / ₁₆	12.0
4 5V 670 SK	6.70	6.60	A-1	SK	2	%	1 ¹ / ₁₆	1 ¹ / ₁₆	1/2	14.0	5 5V 670 SF	A-1	SF	2	%	1 ¹ / ₁₆	2 ¹ / ₁₆	1 ¹ / ₁₆	13.0
4 5V 710 SF	7.10	7.00	A-1	SF	2	%	1 ¹ / ₁₆	2 ¹ / ₁₆	%	15.0	5 5V 710 SF	A-1	SF	2	1 ¹ / ₁₆	1 ¹ / ₁₆	2 ¹ / ₁₆	1	14.0
4 5V 750 SF	7.50	7.40	A-1	SF	2	%	1 ¹ / ₁₆	2 ¹ / ₁₆	%	16.0	5 5V 750 SF	A-1	SF	2	1 ¹ / ₁₆	1 ¹ / ₁₆	2 ¹ / ₁₆	1	16.0
4 5V 800 E	8.00	7.90	B-1	E	3 ¹ / ₂	3/8	1 ¹ / ₁₆	2 ¹ / ₁₆	1/2	19.0	5 5V 800 E	A-1	E	3 ¹ / ₂	3/8	1 ¹ / ₁₆	2 ¹ / ₁₆	1/4	19.0
4 5V 850 E	8.50	8.40	B-1	E	3 ¹ / ₂	3/8	1 ¹ / ₁₆	2 ¹ / ₁₆	1/2	23.0	5 5V 850 E	A-1	E	3 ¹ / ₂	3/8	1 ¹ / ₁₆	2 ¹ / ₁₆	1/4	22.0
4 5V 900 E	9.00	8.90	B-1	E	3 ¹ / ₂	3/8	1 ¹ / ₁₆	2 ¹ / ₁₆	1/2	25.0	5 5V 900 E	A-1	E	3 ¹ / ₂	3/8	1 ¹ / ₁₆	2 ¹ / ₁₆	1/4	26.0
4 5V 925 E	9.25	9.15	B-1	E	3 ¹ / ₂	3/8	1 ¹ / ₁₆	2 ¹ / ₁₆	1/2	26.0	5 5V 925 E	A-1	E	3 ¹ / ₂	3/8	1 ¹ / ₁₆	2 ¹ / ₁₆	1/4	28.0
4 5V 975 E	9.75	9.65	B-1	E	3 ¹ / ₂	3/8	1 ¹ / ₁₆	2 ¹ / ₁₆	1/2	28.0	5 5V 975 E	A-1	E	3 ¹ / ₂	3/8	1 ¹ / ₁₆	2 ¹ / ₁₆	1/4	30.0
4 5V 1030 E	10.30	10.20	B-1	E	3 ¹ / ₂	3/8	1 ¹ / ₁₆	2 ¹ / ₁₆	1/2	30.0	5 5V 1030 E	A-1	E	3 ¹ / ₂	3/8	1 ¹ / ₁₆	2 ¹ / ₁₆	1/4	33.0
4 5V 1090 E	10.90	10.80	B-2	E	3 ¹ / ₂	3/8	1 ¹ / ₁₆	2 ¹ / ₁₆	1/2	39.0	5 5V 1090 E	A-1	E	3 ¹ / ₂	3/8	1 ¹ / ₁₆	2 ¹ / ₁₆	1/4	41.0
4 5V 1130 E	11.30	11.20	B-2	E	3 ¹ / ₂	3/8	1 ¹ / ₁₆	2 ¹ / ₁₆	1/2	40.0	5 5V 1130 E	A-1	E	3 ¹ / ₂	3/8	1 ¹ / ₁₆	2 ¹ / ₁₆	1/4	42.0
4 5V 1180 E	11.80	11.70	B-2	E	3 ¹ / ₂	3/8	1 ¹ / ₁₆	2 ¹ / ₁₆	1/2	41.0	5 5V 1180 E	A-1	E	3 ¹ / ₂	3/8	1 ¹ / ₁₆	2 ¹ / ₁₆	1/4	44.0
4 5V 1250 E	12.50	12.40	B-3	E	3 ¹ / ₂	3/8	1 ¹ / ₁₆	2 ¹ / ₁₆	1/2	43.0	5 5V 1250 E	A-3	E	3 ¹ / ₂	3/8	1 ¹ / ₁₆	2 ¹ / ₁₆	1/4	45.0
4 5V 1320 E	13.20	13.10	B-3	E	3 ¹ / ₂	3/8	1 ¹ / ₁₆	2 ¹ / ₁₆	1/2	45.0	5 5V 1320 E	A-3	E	3 ¹ / ₂	3/8	1 ¹ / ₁₆	2 ¹ / ₁₆	1/4	46.0
4 5V 1400 E	14.00	13.90	B-3	E	3 ¹ / ₂	3/8	1 ¹ / ₁₆	2 ¹ / ₁₆	1/2	46.0	5 5V 1400 E	A-3	E	3 ¹ / ₂	3/8	1 ¹ / ₁₆	2 ¹ / ₁₆	1/4	47.0
4 5V 1500 E	15.00	14.90	B-3	E	3 ¹ / ₂	3/8	1 ¹ / ₁₆	2 ¹ / ₁₆	1/2	47.0	5 5V 1500 E	A-3	E	3 ¹ / ₂	3/8	1 ¹ / ₁₆	2 ¹ / ₁₆	1/4	53.0
4 5V 1600 E	16.00	15.90	B-3	E	3 ¹ / ₂	3/8	1 ¹ / ₁₆	2 ¹ / ₁₆	1/2	49.0	5 5V 1600 E	A-3	E	3 ¹ / ₂	3/8	1 ¹ / ₁₆	2 ¹ / ₁₆	1/4	56.0
4 5V 1870 E	18.70	18.60	A-3	E	3 ¹ / ₂	3/8	1 ¹ / ₁₆	2 ¹ / ₁₆	1/2	71.0	5 5V 1870 F	B-3	F	3 ³ / ₁₆	3/8	1 ¹ / ₁₆	3 ³ / ₁₆	3/8	96.0
4 5V 2120 E	21.20	21.10	A-3	E	3 ¹ / ₂	3/8	1 ¹ / ₁₆	2 ¹ / ₁₆	1/2	72.0	5 5V 2120 F	B-3	F	3 ³ / ₁₆	3/8	1 ¹ / ₁₆	3 ³ / ₁₆	3/8	98.0
4 5V 2360 F	23.60	23.50	C-3	F	3 ³ / ₁₆	1/2	3 ³ / ₁₆	3 ³ / ₁₆	3/4	111.0	5 5V 2360 F	B-3	F	3 ³ / ₁₆	3/8	1 ¹ / ₁₆	3 ³ / ₁₆	3/8	120.0
4 5V 2800 F	28.00	27.90	C-3	F	3 ³ / ₁₆	1/2	3 ³ / ₁₆	3 ³ / ₁₆	3/4	118.0	5 5V 2800 F	B-3	F	3 ³ / ₁₆	3/8	1 ¹ / ₁₆	3 ³ / ₁₆	3/8	135.0
4 5V 3150 F	31.50	31.40	C-3	F	3 ³ / ₁₆	1/2	3 ³ / ₁₆	3 ³ / ₁₆	3/4	146.7	5 5V 3150 J	C-3	J	4 ¹ / ₂	3/8	1	4 ¹ / ₂	3/8	188.0
4 5V 3750 F	37.50	37.40	C-3	F	3 ³ / ₁₆	1/2	3 ³ / ₁₆	3 ³ / ₁₆	3/4	178.0	5 5V 3750 J	C-3	J	4 ¹ / ₂	3/8	1	4 ¹ / ₂	3/8	224.0
4 5V 5000 J	50.00	49.90	C-3	J	4 ¹ / ₂	1/2	1 ¹ / ₁₆	4 ¹ / ₂	1 ⁵ / ₁₆	266.0	5 5V 5000 J	C-3	J	4 ¹ / ₂	3/8	1	4 ¹ / ₂	3/8	308.0

NOTE: Dimensions in inches, weight in pounds. Weights do not include bushings. See page B-3 and B-4 for additional bushing dimensions.
 ☆ E and M dimensions are nominal and will vary depending on shaft tolerances. Type E sheaves are drilled for reverse mounting only.

PLEASE NOTE: Dashes are REQUIRED in place of spaces when ordering or searching on PTplace.com.

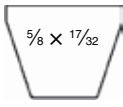
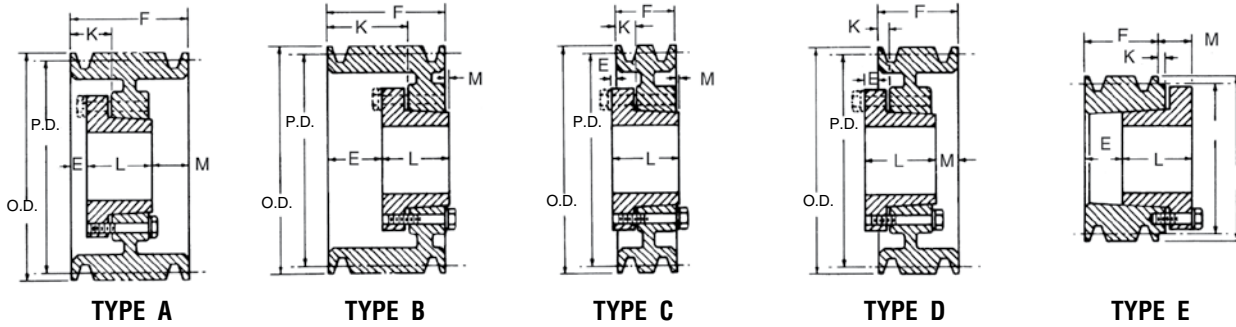

5V QD Sheaves — 5V

1 = SOLID 2 = WEB 3 = ARM/SPOKE

Nomenclature Example: 6-5V-440-SD

6 Groove F = 4 1/16													7 Groove F = 5"							
Part Number	OD	PD 5V Belt	Type	Bush	Bush Max. Bore	E ☆	K	L Length Thru Bore	M ☆	Wt. Less Bush	Part Number	Type	Bush	Bush Max. Bore	E ☆	K	L Length Thru Bore	M ☆	Wt. Less Bush	
6 5V 440 SD	4.40	4.30	E-1	SD	2	3/4	0	1 1/16	5/8	7.0										
6 5V 465 SD	4.65	4.55	E-1	SD	2	3/4	0	1 1/16	5/8	7.8										
6 5V 490 SD	4.90	4.80	A-1	SD	2	1/4	1 1/16	1 1/16	1 1/16	9.0										
6 5V 520 SD	5.20	5.10	A-1	SD	2	1/4	1 1/16	1 1/16	1 1/16	10.8										
6 5V 550 SD	5.50	5.40	A-1	SD	2	1/4	1 1/16	1 1/16	1 1/16	11.3										
6 5V 590 SK	5.90	5.80	A-1	SK	2 3/8	5/8	1 1/16	1 1/16	1 1/16	12.0										
6 5V 630 SK	6.30	6.20	A-1	SK	2 3/8	5/8	1 1/16	1 1/16	1 1/16	13.0										
6 5V 670 SF	6.70	6.60	A-1	SF	2 1/2	5/8	1 1/16	2 1/16	1 1/16	14.0										
6 5V 710 SF	7.10	7.00	A-1	SF	2 1/2	5/8	1 1/16	2 1/16	1 1/16	15.0	7 5V 710 SF	A-1	SF	2 1/2	5/8	1 1/16	2 1/16	2 1/16	2 1/16	17.0
6 5V 750 SF	7.50	7.40	A-1	SF	2 1/2	5/8	1 1/16	2 1/16	1 1/16	17.0	7 5V 750 SF	A-1	SF	2 1/2	5/8	1 1/16	2 1/16	2 1/16	2 1/16	19.0
6 5V 800 E	8.00	7.90	A-1	E	3 1/2	1 1/8	2	2 1/2	1 1/16	20.0	7 5V 800 E	A-1	E	3 1/2	1 1/8	2	2 1/2	1 1/16	1 1/16	22.0
6 5V 850 E	8.50	8.40	A-1	E	3 1/2	1 1/8	2	2 1/2	1 1/16	25.0	7 5V 850 E	A-1	E	3 1/2	1 1/8	2	2 1/2	1 1/16	1 1/16	26.0
6 5V 900 E	9.00	8.90	A-1	E	3 1/2	1 1/8	2	2 1/2	1 1/16	28.0	7 5V 900 E	A-1	E	3 1/2	1 1/8	2	2 1/2	1 1/16	1 1/16	29.0
6 5V 925 E	9.25	9.15	A-1	E	3 1/2	1 1/8	2	2 1/2	1 1/16	29.0	7 5V 925 E	A-1	E	3 1/2	1 1/8	2	2 1/2	1 1/16	1 1/16	33.0
6 5V 975 E	9.75	9.65	A-1	E	3 1/2	1 1/8	2	2 1/2	1 1/16	31.0	7 5V 975 E	A-1	E	3 1/2	1 1/8	2	2 1/2	1 1/16	1 1/16	37.0
6 5V 1030 E	10.30	10.20	A-1	E	3 1/2	1 1/8	2	2 1/2	1 1/16	33.0	7 5V 1030 F	B-1	F	3 1/2	1 1/8	2 1/16	3 3/8	3 3/8	1/2	49.0
6 5V 1090 E	10.90	10.80	A-1	E	3 1/2	1 1/8	2	2 1/2	1 1/16	38.0	7 5V 1090 F	B-1	F	3 1/2	1 1/8	2 1/16	3 3/8	3 3/8	1/2	56.0
6 5V 1130 E	11.30	11.20	A-1	E	3 1/2	1 1/8	2	2 1/2	1 1/16	41.0	7 5V 1130 F	B-1	F	3 1/2	1 1/8	2 1/16	3 3/8	3 3/8	1/2	61.0
6 5V 1180 E	11.80	11.70	A-1	E	3 1/2	1 1/8	2	2 1/2	1 1/16	43.0	7 5V 1180 F	B-2	F	3 1/2	1 1/8	2 1/16	3 3/8	3 3/8	1/2	56.0
6 5V 1250 F	12.50	12.40	B-3	F	3 3/16	1 1/16	2 1/16	3 3/8	3/4	45.0	7 5V 1250 F	B-3	F	3 3/16	1 1/16	2 1/16	3 3/8	3 3/8	1/2	53.0
6 5V 1320 F	13.20	13.10	B-3	F	3 3/16	1 1/16	2 1/16	3 3/8	3/4	48.0	7 5V 1320 F	B-3	F	3 3/16	1 1/16	2 1/16	3 3/8	3 3/8	1/2	52.0
6 5V 1400 F	14.00	13.90	B-3	F	3 3/16	1 1/16	2 1/16	3 3/8	3/4	59.0	7 5V 1400 F	B-3	F	3 3/16	1 1/16	2 1/16	3 3/8	3 3/8	1/2	62.0
6 5V 1500 F	15.00	14.90	B-3	F	3 3/16	1 1/16	2 1/16	3 3/8	3/4	64.0	7 5V 1500 F	B-3	F	3 3/16	1 1/16	2 1/16	3 3/8	3 3/8	1/2	67.0
6 5V 1600 F	16.00	15.90	B-3	F	3 3/16	1 1/16	2 1/16	3 3/8	3/4	68.0	7 5V 1600 F	B-3	F	3 3/16	1 1/16	2 1/16	3 3/8	3 3/8	1/2	77.0
6 5V 1870 F	18.70	18.60	A-3	F	3 3/16	5/16	2 1/16	3 3/8	1/2	83.8	7 5V 1870 F	A-3	F	3 3/16	5/16	2 1/16	3 3/8	3 3/8	1 1/8	99.0
6 5V 2120 F	21.20	21.10	A-3	F	3 3/16	5/16	1 1/16	3 3/8	1/2	110.0	7 5V 2120 J	C-3	J	4 1/2	3/8	1 1/16	4 1/2	7/16	7/16	138.0
6 5V 2360 J	23.60	23.50	B-3	J	4 1/2	3/8	1 1/16	4 1/2	3/8	148.0	7 5V 2360 J	C-3	J	4 1/2	3/8	1 1/16	4 1/2	7/16	7/16	174.0
6 5V 2800 J	28.00	27.90	B-3	J	4 1/2	3/8	1 1/16	4 1/2	3/8	169.0	7 5V 2800 J	C-3	J	4 1/2	3/8	1 1/16	4 1/2	7/16	7/16	169.0
6 5V 3150 J	31.50	31.40	B-3	J	4 1/2	3/8	1 1/16	4 1/2	3/8	206.0	7 5V 3150 J	C-3	J	4 1/2	3/8	1 1/16	4 1/2	7/16	7/16	241.0
6 5V 3750 J	37.50	37.40	B-3	J	4 1/2	3/8	1 1/16	4 1/2	3/8	261.0	7 5V 3750 M	C-3	M	5 1/2	3/8	1 1/16	6 3/4	2 3/8	2 3/8	300.0
6 5V 5000 M	50.00	49.90	C-3	M	5 1/2	3/8	1 1/16	6 3/4	1 1/8	388.0	7 5V 5000 M	C-3	M	5 1/2	3/8	1 1/16	6 3/4	2 3/8	2 3/8	408.0

NOTE: Dimensions in inches, weight in pounds. Weights do not include bushings. See page B-3 and B-4 for additional bushing dimensions.
 ☆ E and M dimensions are nominal and will vary depending on shaft tolerances. Type E sheaves are drilled for reverse mounting only.

PLEASE NOTE: Dashes are REQUIRED in place of spaces when ordering or searching on PTplace.com.

8 Groove F = 5 ¹ / ₁₆											9 Groove F = 6 ¹ / ₂										
Part Number	OD	PD	Type	Bush	Bush Max. Bore	E ☆	K	L Length Thru Bore	M ☆	Wt. Less Bush	Part Number	Type	Bush	Bush Max. Bore	E ☆	K	L Length Thru Bore	M ☆	Wt. Less Bush		
		5V Belt																			
8 5V 710 SF	7.10	7.00	A-1	SF	2 ¹ / ₁₆	1 ¹ / ₁₆	2 ¹ / ₁₆	2 ¹ / ₁₆	2 ¹ / ₁₆	19.0											
8 5V 750 SF	7.50	7.40	A-1	SF	2 ¹ / ₁₆	1 ¹ / ₁₆	2 ¹ / ₁₆	2 ¹ / ₁₆	2 ¹ / ₁₆	20.0											
8 5V 800 E	8.00	7.90	A-1	E	3 ¹ / ₂	1 ¹ / ₁₆	2 ¹ / ₁₆	2 ¹ / ₁₆	1 ¹ / ₁₆	25.0	9 5V 800 E	A-1	E	3 ¹ / ₂	1 ¹ / ₁₆	2 ¹ / ₁₆	2 ¹ / ₁₆	2 ¹ / ₁₆	26.0		
8 5V 850 E	8.50	8.40	A-1	E	3 ¹ / ₂	1 ¹ / ₁₆	2 ¹ / ₁₆	2 ¹ / ₁₆	1 ¹ / ₁₆	29.0	9 5V 850 E	A-1	E	3 ¹ / ₂	1 ¹ / ₁₆	2 ¹ / ₁₆	2 ¹ / ₁₆	2 ¹ / ₁₆	30.0		
8 5V 900 E	9.00	8.90	A-1	E	3 ¹ / ₂	1 ¹ / ₁₆	2 ¹ / ₁₆	2 ¹ / ₁₆	1 ¹ / ₁₆	32.0	9 5V 900 E	A-1	E	3 ¹ / ₂	1 ¹ / ₁₆	2 ¹ / ₁₆	2 ¹ / ₁₆	2 ¹ / ₁₆	33.0		
8 5V 925 F	9.25	9.15	A-1	F	3 ¹ / ₂	1 ¹ / ₁₆	2 ¹ / ₁₆	3 ¹ / ₁₆	%	39.0	9 5V 925 F	A-1	F	3 ¹ / ₂	1 ¹ / ₁₆	2 ¹ / ₁₆	3 ¹ / ₁₆	1 ¹ / ₄	33.0		
8 5V 975 F	9.75	9.65	A-1	F	3 ¹ / ₂	1 ¹ / ₁₆	2 ¹ / ₁₆	3 ¹ / ₁₆	%	42.0	9 5V 975 F	A-1	F	3 ¹ / ₂	1 ¹ / ₁₆	2 ¹ / ₁₆	3 ¹ / ₁₆	1 ¹ / ₄	45.0		
8 5V 1030 F	10.30	10.20	A-1	F	3 ¹ / ₂	1 ¹ / ₁₆	2 ¹ / ₁₆	3 ¹ / ₁₆	%	52.0	9 5V 1030 F	A-1	F	3 ¹ / ₂	1 ¹ / ₁₆	2 ¹ / ₁₆	3 ¹ / ₁₆	1 ¹ / ₄	54.0		
8 5V 1090 F	10.90	10.80	A-1	F	3 ¹ / ₂	1 ¹ / ₁₆	2 ¹ / ₁₆	3 ¹ / ₁₆	%	59.0	9 5V 1090 F	A-1	F	3 ¹ / ₂	1 ¹ / ₁₆	2 ¹ / ₁₆	3 ¹ / ₁₆	1 ¹ / ₄	62.0		
8 5V 1130 F	11.30	11.20	A-1	F	3 ¹ / ₂	1 ¹ / ₁₆	2 ¹ / ₁₆	3 ¹ / ₁₆	%	62.0	9 5V 1130 F	A-1	F	3 ¹ / ₂	1 ¹ / ₁₆	2 ¹ / ₁₆	3 ¹ / ₁₆	1 ¹ / ₄	67.0		
8 5V 1180 F	11.80	11.70	A-1	F	3 ¹ / ₂	1 ¹ / ₁₆	2 ¹ / ₁₆	3 ¹ / ₁₆	%	64.0	9 5V 1180 F	A-1	F	3 ¹ / ₂	1 ¹ / ₁₆	2 ¹ / ₁₆	3 ¹ / ₁₆	1 ¹ / ₄	73.0		
8 5V 1250 F	12.50	12.40	A-3	F	3 ¹ / ₂	1 ¹ / ₁₆	2 ¹ / ₁₆	3 ¹ / ₁₆	%	66.0	9 5V 1250 F	A-3	F	3 ¹ / ₂	1 ¹ / ₁₆	2 ¹ / ₁₆	3 ¹ / ₁₆	1 ¹ / ₄	61.0		
8 5V 1320 F	13.20	13.10	A-3	F	3 ¹ / ₂	1 ¹ / ₁₆	2 ¹ / ₁₆	3 ¹ / ₁₆	%	68.0	9 5V 1320 F	A-3	F	3 ¹ / ₂	1 ¹ / ₁₆	2 ¹ / ₁₆	3 ¹ / ₁₆	1 ¹ / ₄	60.0		
8 5V 1400 F	14.00	13.90	A-3	F	3 ¹ / ₂	1 ¹ / ₁₆	2 ¹ / ₁₆	3 ¹ / ₁₆	%	70.0	9 5V 1400 F	A-3	F	3 ¹ / ₂	1 ¹ / ₁₆	2 ¹ / ₁₆	3 ¹ / ₁₆	1 ¹ / ₄	70.0		
8 5V 1500 F	15.00	14.90	A-3	F	3 ¹ / ₂	1 ¹ / ₁₆	2 ¹ / ₁₆	3 ¹ / ₁₆	%	73.0	9 5V 1500 J	B-2	J	4 ¹ / ₂	2 ¹ / ₁₆	3 ¹ / ₁₆	4 ¹ / ₂	7 ¹ / ₁₆	95.0		
8 5V 1600 F	16.00	15.90	A-3	F	3 ¹ / ₂	1 ¹ / ₁₆	1 ¹ / ₁₆	3 ¹ / ₁₆	%	89.0	9 5V 1600 J	B-2	J	4 ¹ / ₂	2 ¹ / ₁₆	3 ¹ / ₁₆	4 ¹ / ₂	7 ¹ / ₁₆	103.0		
8 5V 1870 J	18.70	18.60	A-3	J	4 ¹ / ₂	3 ¹ / ₁₆	1 ¹ / ₁₆	4 ¹ / ₂	1 ¹ / ₁₆	132.0	9 5V 1870 J	A-3	J	4 ¹ / ₂	7 ¹ / ₁₆	1 ¹ / ₁₆	4 ¹ / ₂	1 ¹ / ₁₆	140.0		
8 5V 2120 J	21.20	21.10	A-3	J	4 ¹ / ₂	3 ¹ / ₁₆	1 ¹ / ₁₆	4 ¹ / ₂	1 ¹ / ₁₆	150.0	9 5V 2120 J	A-3	J	4 ¹ / ₂	7 ¹ / ₁₆	1 ¹ / ₁₆	4 ¹ / ₂	1 ¹ / ₁₆	152.0		
8 5V 2360 J	23.60	23.50	A-3	J	4 ¹ / ₂	3 ¹ / ₁₆	1 ¹ / ₁₆	4 ¹ / ₂	1 ¹ / ₁₆	162.0	9 5V 2360 J	A-3	J	4 ¹ / ₂	7 ¹ / ₁₆	1 ¹ / ₁₆	4 ¹ / ₂	1 ¹ / ₁₆	176.0		
8 5V 2800 J	28.00	27.90	A-3	J	4 ¹ / ₂	3 ¹ / ₁₆	1 ¹ / ₁₆	4 ¹ / ₂	1 ¹ / ₁₆	191.0	9 5V 2800 M	B-3	M	5 ¹ / ₂	3 ¹ / ₁₆	1 ¹ / ₁₆	6 ¹ / ₁₆	1 ¹ / ₁₆	265.0		
8 5V 3150 M	31.50	31.40	B-3	M	5 ¹ / ₂	1 ¹ / ₁₆	1 ¹ / ₁₆	6 ¹ / ₁₆	1 ¹ / ₁₆	298.0	9 5V 3150 M	B-3	M	5 ¹ / ₂	3 ¹ / ₁₆	1 ¹ / ₁₆	6 ¹ / ₁₆	1 ¹ / ₁₆	313.0		
8 5V 3750 M	37.50	37.40	B-3	M	5 ¹ / ₂	1 ¹ / ₁₆	1 ¹ / ₁₆	6 ¹ / ₁₆	1 ¹ / ₁₆	319.0	9 5V 3750 M	B-3	M	5 ¹ / ₂	3 ¹ / ₁₆	1 ¹ / ₁₆	6 ¹ / ₁₆	1 ¹ / ₁₆	409.0		
8 5V 5000 M	50.00	49.90	B-3	M	5 ¹ / ₂	1 ¹ / ₁₆	1 ¹ / ₁₆	6 ¹ / ₁₆	1 ¹ / ₁₆	497.0	9 5V 5000 M	B-3	M	5 ¹ / ₂	3 ¹ / ₁₆	1 ¹ / ₁₆	6 ¹ / ₁₆	1 ¹ / ₁₆	483.0		

NOTE: Dimensions in inches, weight in pounds. Weights do not include bushings. See page B-3 and B-4 for additional bushing dimensions.
 ☆ E and M dimensions are nominal and will vary depending on shaft tolerances. Type E sheaves are drilled for reverse mounting only.

PLEASE NOTE: Dashes are REQUIRED in place of spaces when ordering or searching on PTplace.com.

QD Sheaves — 5V

Nomenclature Example: 10-5V-800-E

10 Groove F = 7 ³ / ₁₆										
Part Number	OD	PD	Type	Bush	Bush Max. Bore	E ☆	K	L Length Thru Bore	M ☆	Wt. Less Bush
		5V Belt								
10 5V 800 E	8.00	7.90	A-1	E	3 ¹ / ₂	2 ¹ / ₁₆	3 ¹ / ₁₆	2 ¹ / ₁₆	2 ¹ / ₁₆	27.0
10 5V 850 E	8.50	8.40	A-1	E	3 ¹ / ₂	2 ¹ / ₁₆	3 ¹ / ₁₆	2 ¹ / ₁₆	2 ¹ / ₁₆	32.0
10 5V 900 F	9.00	8.90	A-1	F	3 ¹ / ₂	2 ¹ / ₁₆	3 ¹ / ₁₆	3 ¹ / ₁₆	1 ¹ / ₄	41.0
10 5V 925 F	9.25	9.15	A-1	F	3 ¹ / ₂	2 ¹ / ₁₆	3 ¹ / ₁₆	3 ¹ / ₁₆	1 ¹ / ₄	47.0
10 5V 975 F	9.75	9.65	A-1	F	3 ¹ / ₂	2 ¹ / ₁₆	3 ¹ / ₁₆	3 ¹ / ₁₆	1 ¹ / ₄	58.0
10 5V 1030 F	10.30	10.20	A-1	F	3 ¹ / ₂	2 ¹ / ₁₆	3 ¹ / ₁₆	3 ¹ / ₁₆	1 ¹ / ₄	66.0
10 5V 1090 F	10.90	10.80	A-1	F	3 ¹ / ₂	2 ¹ / ₁₆	3 ¹ / ₁₆	3 ¹ / ₁₆	1 ¹ / ₄	75.0
10 5V 1130 F	11.30	11.20	A-1	F	3 ¹ / ₂	2 ¹ / ₁₆	3 ¹ / ₁₆	3 ¹ / ₁₆	1 ¹ / ₄	79.0
10 5V 1180 F	11.80	11.70	A-1	F	3 ¹ / ₂	2 ¹ / ₁₆	3 ¹ / ₁₆	3 ¹ / ₁₆	1 ¹ / ₄	80.0
10 5V 1250 J	12.50	12.40	A-1	J	4 ¹ / ₂	2 ¹ / ₁₆	3 ¹ / ₁₆	4 ¹ / ₂	3 ¹ / ₁₆	82.0
10 5V 1320 J	13.20	13.10	A-1	J	4 ¹ / ₂	2 ¹ / ₁₆	3 ¹ / ₁₆	4 ¹ / ₂	3 ¹ / ₁₆	85.0
10 5V 1400 J	14.00	13.90	A-1	J	4 ¹ / ₂	2 ¹ / ₁₆	3 ¹ / ₁₆	4 ¹ / ₂	3 ¹ / ₁₆	90.0
10 5V 1500 J	15.00	14.90	A-2	J	4 ¹ / ₂	2 ¹ / ₁₆	3 ¹ / ₁₆	4 ¹ / ₂	3 ¹ / ₁₆	92.0
10 5V 1600 J	16.00	15.90	A-1	J	4 ¹ / ₂	2 ¹ / ₁₆	3 ¹ / ₁₆	4 ¹ / ₂	3 ¹ / ₁₆	102.0
10 5V 1870 J	18.70	18.60	A-3	J	4 ¹ / ₂	3 ¹ / ₁₆	1 ¹ / ₁₆	4 ¹ / ₂	2 ¹ / ₁₆	150.0
10 5V 2120 J	21.20	21.10	A-3	J	4 ¹ / ₂	3 ¹ / ₁₆	1 ¹ / ₁₆	4 ¹ / ₂	2 ¹ / ₁₆	164.0
10 5V 2360 M	23.60	23.50	B-3	M	5 ¹ / ₂	1 ¹ / ₁₆	1 ¹ / ₁₆	6 ¹ / ₁₆	1 ¹ / ₁₆	258.0
10 5V 2800 M	28.00	27.90	B-3	M	5 ¹ / ₂	1 ¹ / ₁₆	1 ¹ / ₁₆	6 ¹ / ₁₆	1 ¹ / ₁₆	278.0
10 5V 3150 M	31.50	31.40	B-3	M	5 ¹ / ₂	1 ¹ / ₁₆	1 ¹ / ₁₆	6 ¹ / ₁₆	1 ¹ / ₁₆	318.0
10 5V 3750 M	37.50	37.40	B-3	M	5 ¹ / ₂	1 ¹ / ₁₆	1 ¹ / ₁₆	6 ¹ / ₁₆	1 ¹ / ₁₆	340.0
10 5V 5000 M	50.00	49.90	B-3	M	5 ¹ / ₂	1 ¹ / ₁₆	1 ¹ / ₁₆	6 ¹ / ₁₆	1 ¹ / ₁₆	538.0

NOTE: Dimensions in inches, weight in pounds. Weights do not include bushings. See page B-3 and B-4 for additional bushing dimensions.

☆ E and M dimensions are nominal and will vary depending on shaft tolerances.
 Type E sheaves are drilled for reverse mounting only.

QD Sheaves — 8V

Nomenclature Example: **4-8V-1250-F**

4 Groove F = 4 1/8											5 Groove F = 6										
Part Number	OD	PD 8V Belt	Type	Bush	Bush Max. Bore	E ☆	K	L Length Thru Bore		Wt. Less Bush	Part Number	Type	Bush	Bush Max. Bore	E ☆	K	L Length Thru Bore		Wt. Less Bush		
								M ☆									M ☆				
4 8V 1250 F	12.50	12.30	A-1	F	3 3/16	3/16	1 1/8	3 3/8	1 1/8	63.0	5 8V 1250 F	A-1	F	3 3/16	1 1/8	2 1/8	3 3/8	1 1/8	68.0		
4 8V 1320 F	13.20	13.00	A-2	F	3 3/16	3/16	1 1/8	3 3/8	1 1/8	66.0	5 8V 1320 F	A-2	F	3 3/16	1 1/8	2 1/8	3 3/8	1 1/8	75.0		
4 8V 1400 F	14.00	13.80	A-2	F	3 3/16	3/16	1 1/8	3 3/8	1 1/8	70.0	5 8V 1400 F	A-2	F	3 3/16	1 1/8	2 1/8	3 3/8	1 1/8	78.0		
4 8V 1500 F	15.00	14.80	A-2	F	3 3/16	3/16	1 1/8	3 3/8	1 1/8	74.0	5 8V 1500 F	A-2	F	3 3/16	1 1/8	2 1/8	3 3/8	1 1/8	94.0		
4 8V 1600 F	16.00	15.80	A-2	F	3 3/16	3/16	1 1/8	3 3/8	1 1/8	82.0	5 8V 1600 F	A-2	F	3 3/16	1 1/8	2 1/8	3 3/8	1 1/8	101.0		
4 8V 1700 F	17.00	16.80	A-3	F	3 3/16	3/16	1 1/8	3 3/8	1 1/8	94.0	5 8V 1700 J	A-3	J	4 1/2	1 3/8	2	4 1/2	1 1/8	111.0		
4 8V 1800 F	18.00	17.80	A-3	F	3 3/16	3/16	1 1/8	3 3/8	1 1/8	99.0	5 8V 1800 J	A-3	J	4 1/2	1 3/8	2	4 1/2	1 1/8	130.0		
4 8V 1900 F	19.00	18.80	A-3	F	3 3/16	3/16	1 1/8	3 3/8	1 1/8	105.0	5 8V 1900 J	A-3	J	4 1/2	1 3/8	2	4 1/2	1 1/8	135.0		
4 8V 2000 J	20.00	19.80	A-3	J	4 1/2	1/4	1 1/8	4 1/2	1/2	141.0	5 8V 2000 J	A-3	J	4 1/2	1 3/8	2	4 1/2	1 1/8	152.0		
4 8V 2120 J	21.20	21.00	A-3	J	4 1/2	1/4	1 1/8	4 1/2	1/2	150.0	5 8V 2120 J	A-3	J	4 1/2	1 3/8	2	4 1/2	1 1/8	153.0		
4 8V 2240 J	22.40	22.20	A-3	J	4 1/2	1/4	1 1/8	4 1/2	1/2	177.0	5 8V 2240 M	B-3	M	5 1/2	1/2	1 1/8	6 3/4	1 1/4	223.0		
4 8V 2480 M	24.80	24.60	C-3	M	5 1/2	1/2	1 1/8	6 3/4	1 1/4	223.0	5 8V 2480 M	B-3	M	5 1/2	1/2	1 1/8	6 3/4	1 1/4	234.0		
4 8V 3000 M	30.00	29.80	C-3	M	5 1/2	1/2	1 1/8	6 3/4	1 1/4	285.0	5 8V 3000 M	B-3	M	5 1/2	1/2	1 1/8	6 3/4	1 1/4	294.0		
4 8V 3550 M	35.50	35.30	C-3	M	5 1/2	1/2	1 1/8	6 3/4	1 1/4	305.0	5 8V 3550 M	B-3	M	5 1/2	1/2	1 1/8	6 3/4	1 1/4	325.0		
4 8V 4000 M	40.00	39.80	C-3	M	5 1/2	1/2	1 1/8	6 3/4	1 1/4	355.0	5 8V 4000 M	B-3	M	5 1/2	1/2	1 1/8	6 3/4	1 1/4	430.0		
4 8V 4450 M	44.50	44.30	C-3	M	5 1/2	1/2	1 1/8	6 3/4	1 1/4	369.0	5 8V 4450 N	C-3	N	6	1 3/8	1 1/8	8 1/2	1 1/8	485.0		
4 8V 5300 M	53.00	52.80	C-3	M	5 1/2	1/2	1 1/8	6 3/4	1 1/4	478.0	5 8V 5300 N	C-3	N	6	1 3/8	1 1/8	8 1/2	1 1/8	672.0		

NOTE: Dimensions in inches, weight in pounds. Weights do not include bushings. See page B-3 and B-4 for additional bushing dimensions.

☆ E and M dimensions are nominal and will vary depending on shaft tolerances. Type E sheaves are drilled for reverse mounting only.

QD Sheaves — 8V

Nomenclature Example: **6-8V-1250-F**

6 Groove F = 7 1/8											8 Groove F = 9 3/8										
Part Number	OD	PD 8V Belt	Type	Bush	Bush Max. Bore	E ☆	K	L Length Thru Bore		Wt. Less Bush	Part Number	Type	Bush	Bush Max. Bore	E ☆	K	L Length Thru Bore		Wt. Less Bush		
								M ☆									M ☆				
6 8V 1250 F	12.50	12.30	A-1	F	3 3/16	1 1/8	2 1/8	3 3/8	2 1/8	86.0	8 8V 1250 J	A-1	J	4 1/2	2 1/8	3 3/8	4 1/2	2 1/2	108.0		
6 8V 1320 F	13.20	13.00	A-1	F	3 3/16	1 1/8	2 1/8	3 3/8	2 1/8	94.0	8 8V 1320 J	A-1	J	4 1/2	2 1/8	3 3/8	4 1/2	2 1/2	118.0		
6 8V 1400 F	14.00	13.80	A-1	F	3 3/16	1 1/8	2 1/8	3 3/8	2 1/8	108.0	8 8V 1400 J	A-1	J	4 1/2	2 1/8	3 3/8	4 1/2	2 1/2	131.0		
6 8V 1500 J	15.00	14.80	A-1	J	4 1/2	1 1/8	2 1/8	4 1/2	1 1/4	138.0	8 8V 1500 J	A-1	J	4 1/2	2 1/8	3 3/8	4 1/2	2 1/2	151.0		
6 8V 1600 J	16.00	15.80	A-1	J	4 1/2	1 1/8	2 1/8	4 1/2	1 1/4	142.0	8 8V 1600 J	A-1	J	4 1/2	2 1/8	3 3/8	4 1/2	2 1/2	155.0		
6 8V 1700 J	17.00	16.80	A-2	J	4 1/2	1 1/8	2 1/8	4 1/2	1 1/4	144.0	8 8V 1700 M	A-2	M	5 1/2	2 1/8	3 3/8	6 3/4	1/2	188.0		
6 8V 1800 J	18.00	17.80	A-2	J	4 1/2	1 1/8	2 1/8	4 1/2	1 1/4	160.0	8 8V 1800 M	A-2	M	5 1/2	2 1/8	3 3/8	6 3/4	1/2	202.0		
6 8V 1900 J	19.00	18.80	A-2	J	4 1/2	1 1/8	2 1/8	4 1/2	1 1/4	172.0	8 8V 1900 M	A-2	M	5 1/2	2 1/8	3 3/8	6 3/4	1/2	221.0		
6 8V 2000 M	20.00	19.80	B-2	M	5 1/2	1 1/2	2 1/8	6 3/4	1 1/2	204.0	8 8V 2000 M	A-2	M	5 1/2	2 1/8	3 3/8	6 3/4	1/2	236.0		
6 8V 2120 M	21.20	21.00	B-2	M	5 1/2	1 1/2	2 1/8	6 3/4	1 1/2	226.0	8 8V 2120 M	A-2	M	5 1/2	2 1/8	3 3/8	6 3/4	1/2	267.0		
6 8V 2240 M	22.40	22.20	B-3	M	5 1/2	1 1/2	2 1/8	6 3/4	1 1/2	235.0	8 8V 2240 M	A-3	M	5 1/2	2 1/8	3 3/8	6 3/4	1/2	284.0		
6 8V 2480 M	24.80	24.60	B-3	M	5 1/2	1 1/2	1 1/8	6 3/4	1 1/2	246.0	8 8V 2480 N	A-2	N	6	1/2	2 1/4	8 1/2	3/4	418.0		
6 8V 3000 M	30.00	29.80	B-3	M	6	1 1/2	1 1/8	6 3/4	1 1/2	306.0	8 8V 3000 N	A-3	N	6	1/2	2 1/4	8 1/2	3/4	447.0		
6 8V 3550 N	35.50	35.30	C-3	N	6	1 1/2	1 1/8	8 1/2	3/4	466.0	8 8V 3550 N	A-3	N	6	1/2	2 1/4	8 1/2	3/4	553.0		
6 8V 4000 N	40.00	39.80	C-3	N	6	1 1/2	1 1/8	8 1/2	3/4	548.0	8 8V 4000 N	A-3	N	6	1/2	2 1/4	8 1/2	3/4	648.0		
6 8V 4450 N	44.50	44.30	C-3	N	6	1 1/2	1 1/8	8 1/2	3/4	590.0	8 8V 4450 P	B-3	P	6 3/4	1/2	2 1/8	9 3/4	1/2	679.0		
6 8V 5300 N	53.00	52.80	C-3	N	6	1 1/2	1 1/8	8 1/2	3/4	658.0	8 8V 5300 P	B-3	P	6 3/4	1/2	2 1/8	9 3/4	1/2	946.0		
6 8V 6300 P	63.00	62.80	C-3	P	6 3/4	0	2	9 3/4	1 1/2	860.0	8 8V 6300 P	B-3	P	6 3/4	1/2	2 1/8	9 3/4	1/2	1372.0		
6 8V 7100 P	71.00	70.80	B-3	P	6 3/4	0	2	9 3/4	1 1/2	1272.0	8 8V 7100 W	C-3	W	8 1/2	1/2	1 1/2	11 1/2	3/4	1680.0		

NOTE: Dimensions in inches, weight in pounds. Weights do not include bushings. See page B-3 and B-4 for additional bushing dimensions.

☆ E and M dimensions are nominal and will vary depending on shaft tolerances. Type E sheaves are drilled for reverse mounting only.

PLEASE NOTE: Dashes are REQUIRED in place of spaces when ordering or searching on PTplace.com.

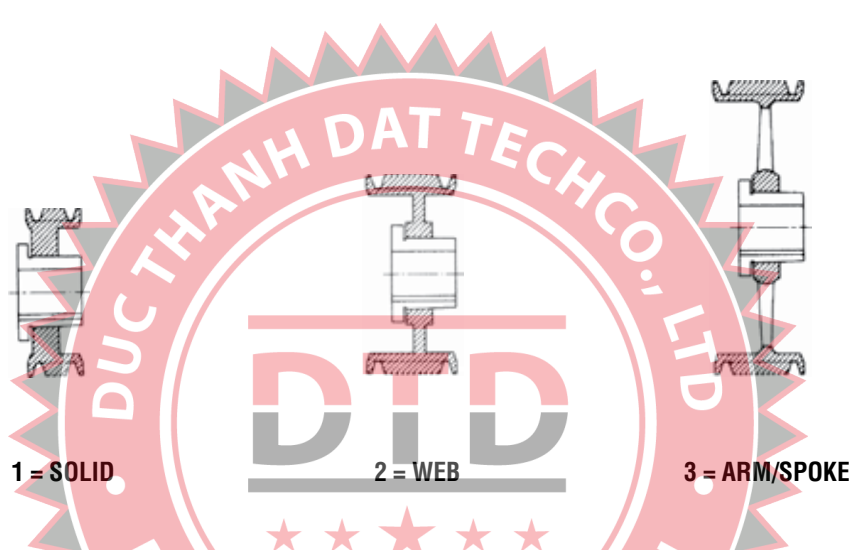
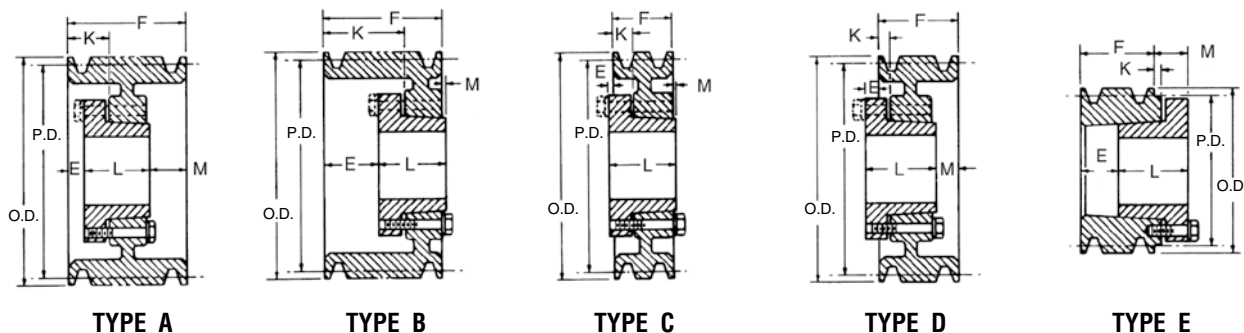

V-Belt | QD Sheaves

QD Sheaves — 8V

Nomenclature Example: 10-8V-1250-J

10 Groove F = 11 5/8											12 Groove F = 14										
Part Number	OD	PD 8V Belt	Type	Bush	Bush Max. Bore	E ☆	K	L Length Thru Bore	M ☆	Wt. Less Bush	Part Number	Type	Bush	Bush Max. Bore	E ☆	K	L Length Thru Bore	M ☆	Wt. Less Bush		
10 8V 1250 J	12.50	12.30	A-1	J	4 1/2	2%	3 3/8	4 1/2	4%	122.0	12 8V 1250 M	A-1	M	5 1/2	2 1/2	3 3/8	6%	4%	161.0		
10 8V 1320 J	13.20	13.00	A-1	J	4 1/2	2%	3 3/8	4 1/2	4%	140.0	12 8V 1320 M	A-1	M	5 1/2	2 1/2	3 3/8	6%	4%	185.0		
10 8V 1400 J	14.00	13.80	A-1	J	4 1/2	2%	3 3/8	4 1/2	4%	152.0	12 8V 1400 M	A-1	M	5 1/2	2 1/2	3 3/8	6%	4%	211.0		
10 8V 1500 M	15.00	14.80	A-1	M	5 1/2	2 1/2	3 3/8	6%	2%	212.0	12 8V 1500 M	A-1	M	5 1/2	2 1/2	3 3/8	6%	4%	234.0		
10 8V 1600 M	16.00	15.80	A-1	M	5 1/2	2 1/2	3 3/8	6%	2%	219.0	12 8V 1600 M	A-1	M	5 1/2	2 1/2	3 3/8	6%	4%	285.0		
10 8V 1700 M	17.00	16.80	A-2	M	5 1/2	2 1/2	3 3/8	6%	2%	228.0	12 8V 1700 M	A-1	M	5 1/2	2 1/2	3 3/8	6%	4%	324.0		
10 8V 1800 M	18.00	17.80	A-2	M	5 1/2	2 1/2	3 3/8	6%	2%	236.0	12 8V 1800 M	A-2	M	5 1/2	2 1/2	3 3/8	6%	4%	330.0		
10 8V 1900 M	19.00	18.80	A-2	M	5 1/2	2 1/2	3 3/8	6%	2%	260.0	12 8V 1900 N	A-2	N	6	1/2	2 1/2	8 1/2	5 1/2	338.0		
10 8V 2000 M	20.00	19.80	A-2	M	5 1/2	2 1/2	3 3/8	6%	2%	280.0	12 8V 2000 N	A-2	N	6	1/2	2 1/2	8 1/2	5 1/2	365.0		
10 8V 2120 M	21.20	21.00	A-2	M	5 1/2	2 1/2	3 3/8	6%	2%	298.0	12 8V 2120 N	A-2	N	6	1/2	2 1/2	8 1/2	5 1/2	382.0		
10 8V 2240 N	22.40	22.20	A-2	N	6	1/2	2 1/2	8%	3%	366.0	12 8V 2240 N	A-2	N	6	1/2	2 1/2	8%	5 1/2	399.0		
10 8V 2480 N	24.80	24.60	A-2	N	6	1/2	2 1/2	8%	3%	454.0	12 8V 2480 N	A-2	N	6	1/2	2 1/2	8%	5 1/2	454.0		
10 8V 3000 N	30.00	29.80	A-3	N	6	1/2	2 1/2	8%	3%	468.0	12 8V 3000 P	A-3	P	6%	%	2%	9%	3%	605.0		
10 8V 3550 P	35.50	35.30	A-3	P	6%	%	2%	9%	1%	784.0	12 8V 3550 P	A-3	P	6%	%	2%	9%	3%	706.0		
10 8V 4000 P	40.00	39.80	A-3	P	6%	%	2%	9%	1%	826.0	12 8V 4000 P	A-3	P	6%	%	2%	9%	3%	766.0		
10 8V 4450 P	44.50	44.30	A-3	P	6%	%	2%	9%	1%	996.0	12 8V 4450 P	A-3	P	6%	%	2%	9%	3%	910.0		
10 8V 5300 P	53.00	52.80	A-3	P	6%	%	2%	9%	1/2	1010.0	12 8V 5300 W	A-3	W	8%	%	2%	11%	2%	1333.0		
10 8V 6300 W	63.00	62.80	A-3	W	8 1/2	%	2%	11%	0	1443.0	12 8V 6300 W	A-3	W	8%	%	2%	11%	2%	1777.0		
10 8V 7100 W	71.00	70.80	A-3	W	8 1/2	%	2%	11%	0	1842.0	12 8V 7100 W	A-3	W	8%	%	2%	11%	2%	2002.0		

NOTE: Dimensions in inches, weight in pounds. Weights do not include bushings. See page B-3 and B-4 for additional bushing dimensions.
 ☆ E and M dimensions are nominal and will vary depending on shaft tolerances. Type E sheaves are drilled for reverse mounting only.

PLEASE NOTE: Dashes are REQUIRED in place of spaces when ordering or searching on PTplace.com.

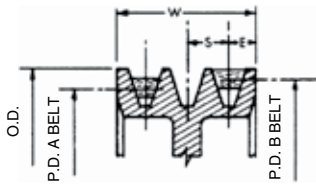

Combination Groove Dimensions

Belt Section	E	S	O.D.
"AB"	1/2	3/4	P.D. "B" + .35



A

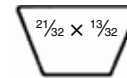

B

Drawing shows position of "A" and "B" belts in groove when used with QD sheaves.

QD Sheaves — A-B

Nomenclature Example: **1-B-34-SH**

1 Groove F = 3/8 thru 1 B 64 SDS / F = 1 others												2 Groove F = 1%								
Part Number	PD		OD	Type	Bush	Bush Max. Bore	E ☆	K	L Length Thru Bore	M ☆	Wt. Less Bush	Part Number	Type	Bush	Bush Max. Bore	E ☆	K	L Length Thru Bore	M ☆	Wt. Less Bush
	A Belts	B Belts																		
1 B 34 SH	3.0	3.4	3.75	D-1	SH	1 1/16	3/16	0	1 1/16	1/8	1.4	2 B 34 SH	E-1	SH	1 1/16	1	0	1 1/16	3/16	2.8
1 B 36 SH	3.2	3.6	3.95	D-1	SH	1 1/16	3/16	0	1 1/16	1/8	1.6	2 B 36 SH	D-1	SH	1 1/16	3/8	3/16	1 1/16	13/16	2.8
1 B 38 SH	3.4	3.8	4.15	D-1	SH	1 1/16	3/16	0	1 1/16	1/8	1.2	2 B 38 SH	D-1	SH	1 1/16	3/8	3/16	1 1/16	13/16	3.3
1 B 40 SH	3.6	4.0	4.35	C-1	SH	1 1/16	1/4	3/16	1 1/16	3/16	2.2	2 B 40 SH	A-1	SH	1 1/16	1/2	1/16	1 1/16	5/16	3.4
1 B 42 SH	3.8	4.2	4.55	C-1	SH	1 1/16	1/4	3/16	1 1/16	3/16	6.9	2 B 42 SH	A-1	SH	1 1/16	1/2	1/16	1 1/16	5/16	3.8
1 B 44 SH	4.0	4.4	4.75	C-1	SH	1 1/16	1/4	3/16	1 1/16	3/16	2.9	2 B 44 SH	A-1	SH	1 1/16	1/2	1/16	1 1/16	5/16	4.6
1 B 46 SDS	4.2	4.6	4.95	C-1	SDS	2	3/16	3/16	1 1/16	3/16	2.6	2 B 46 SDS	A-2	SDS	2	1/16	1/16	1 1/16	1 1/16	4.3
1 B 48 SDS	4.4	4.8	5.15	C-1	SDS	2	3/16	3/16	1 1/16	3/16	3.1	2 B 48 SDS	A-2	SDS	2	1/16	1/16	1 1/16	1 1/16	4.8
1 B 50 SDS	4.6	5.0	5.35	C-1	SDS	2	3/16	3/16	1 1/16	3/16	3.5	2 B 50 SDS	A-2	SDS	2	1/16	1/16	1 1/16	1 1/16	5.5
1 B 52 SDS	4.8	5.2	5.55	C-1	SDS	2	3/16	3/16	1 1/16	3/16	3.7	2 B 52 SDS	A-2	SDS	2	1/16	1/16	1 1/16	1 1/16	5.8
1 B 54 SDS	5.0	5.4	5.75	C-1	SDS	2	3/16	3/16	1 1/16	3/16	4.0	2 B 54 SDS	A-2	SDS	2	1/16	1/16	1 1/16	1 1/16	6.1
1 B 56 SDS	5.2	5.6	5.95	C-1	SDS	2	3/16	3/16	1 1/16	3/16	4.2	2 B 56 SDS	A-2	SDS	2	1/16	1/16	1 1/16	1 1/16	6.6
1 B 58 SDS	5.4	5.8	6.15	C-1	SDS	2	3/16	3/16	1 1/16	3/16	4.5	2 B 58 SDS	A-1	SDS	2	1/16	1/16	1 1/16	1 1/16	7.2
1 B 60 SDS	5.6	6.0	6.35	C-1	SDS	2	3/16	3/16	1 1/16	3/16	4.9	2 B 60 SDS	A-2	SDS	2	1/16	1/16	1 1/16	1 1/16	7.6
1 B 62 SDS	5.8	6.2	6.55	C-2	SDS	2	3/16	3/16	1 1/16	3/16	5.5	2 B 62 SDS	A-2	SDS	2	1/16	1/16	1 1/16	1 1/16	7.0
1 B 64 SDS	6.0	6.4	6.75	C-2	SDS	2	3/16	3/16	1 1/16	3/16	5.7	2 B 64 SDS	A-2	SDS	2	1/16	1/16	1 1/16	1 1/16	7.0
1 B 66 SDS	6.2	6.6	6.95	C-2	SDS	2	3/16	3/16	1 1/16	3/16	5.9	2 B 66 SDS	A-2	SDS	2	1/16	1/16	1 1/16	1 1/16	9.0
1 B 68 SDS	6.4	6.8	7.15	C-2	SDS	2	3/16	3/16	1 1/16	3/16	4.8	2 B 68 SDS	A-2	SDS	2	1/16	1/16	1 1/16	1 1/16	9.2
1 B 70 SDS	6.6	7.0	7.35	C-2	SDS	2	1/2	1/2	1 1/16	1/2	5.8	2 B 70 SK	D-2	SK	2 1/2	3/4	3/16	1 1/16	1/16	8.8
1 B 74 SDS	7.0	7.4	7.75	C-2	SDS	2	1/2	1/2	1 1/16	1/2	6.4	2 B 74 SK	D-2	SK	2 3/4	3/4	3/16	1 1/16	1/16	11.0
1 B 80 SDS	7.6	8.0	8.35	C-3	SDS	2	1/2	1/2	1 1/16	1/2	6.8	2 B 80 SK	D-2	SK	2 3/4	3/4	3/16	1 1/16	1/16	12.6
1 B 86 SDS	8.2	8.6	8.95	C-3	SDS	2	1/2	1/2	1 1/16	1/2	7.2	2 B 86 SK	D-3	SK	2 3/4	3/4	3/16	1 1/16	1/16	12.0
1 B 94 SDS	9.0	9.4	9.75	C-3	SDS	2	1/2	1/2	1 1/16	1/2	8.0	2 B 94 SK	D-3	SK	2 3/4	3/4	3/16	1 1/16	1/16	13.4
1 B 110 SDS	10.6	11.0	11.35	C-3	SDS	2	1/2	1/2	1 1/16	1/2	9.0	2 B 110 SK	D-3	SK	2 3/4	3/4	3/16	1 1/16	1/16	16.4
1 B 124 SDS	12.0	12.4	12.75	C-3	SDS	2	1/2	1/2	1 1/16	1/2	11.0	2 B 124 SK	D-3	SK	2 3/4	3/4	3/16	1 1/16	1/16	19.2
1 B 136 SDS	13.2	13.6	13.95	C-3	SDS	2	1/2	1/2	1 1/16	1/2	12.0	2 B 136 SK	D-3	SK	2 3/4	3/4	3/16	1 1/16	1/16	19.0
1 B 154 SK	15.0	15.4	15.75	C-3	SK	2 3/8	3/16	1/2	1 1/16	3/8	13.0	2 B 154 SK	D-3	SK	2 3/4	3/4	3/16	1 1/16	1/16	22.0
1 B 160 SK	15.6	16.0	16.35	C-3	SK	2 3/8	3/16	1/2	1 1/16	3/8	15.0	2 B 160 SK	D-3	SK	2 3/4	3/4	3/16	1 1/16	1/16	26.0
1 B 184 SK	18.0	18.4	18.75	C-3	SK	2 3/8	3/16	1/2	1 1/16	3/8	19.0	2 B 184 SK	D-3	SK	2 3/4	3/4	3/16	1 1/16	1/16	30.0
1 B 200 SK	19.6	20.0	20.35	C-3	SK	2 3/8	3/16	1/2	1 1/16	3/8	25.0	2 B 200 SF	D-3	SF	2 1/2	3/16	3/8	2 1/16	0	35.0
	24.6	25.0	25.35									2 B 250 SF	D-3	SF	2 1/2	3/16	3/8	2 1/16	0	57.0
	29.6	30.0	30.35									2 B 300 SF	D-3	SF	2 1/2	3/16	3/8	2 1/16	0	80.0
	37.6	38.0	38.35									2 B 380 SF	D-3	SF	2 1/2	3/16	3/8	2 1/16	0	99.0

NOTE: Dimensions in inches, weight in pounds. Weights do not include bushings. See page B-3 and B-4 for additional bushing dimensions.
 ☆ E and M dimensions are nominal and will vary depending on shaft tolerances. Type E sheaves are drilled for reverse mounting only.

PLEASE NOTE: Dashes are REQUIRED in place of spaces when ordering or searching on PTplace.com.

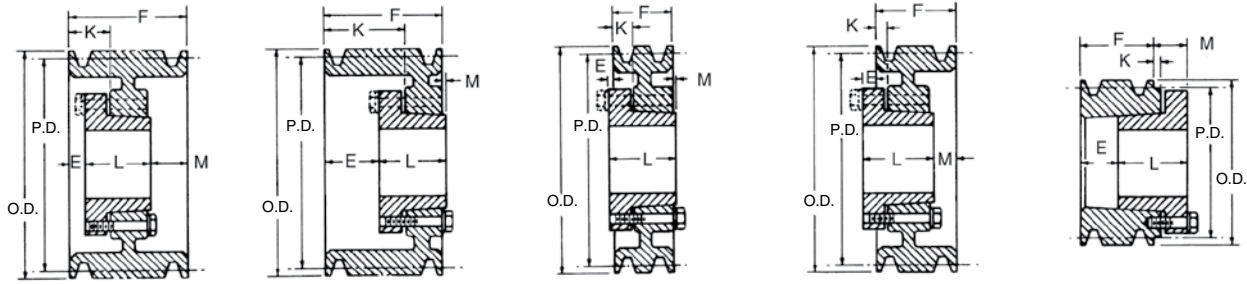

TYPE A

TYPE B

TYPE C

TYPE D

TYPE E

QD Sheaves — A-B

Nomenclature Example: **3-B-34-SH**

3 Groove F = 2 1/2											4 Groove F = 3 1/4										
Part Number	PD		OD	Type	Bush	Bush Max. Bore	E ☆	K	L Length Thru Bore	M ☆	Wt. Less Bush	Part Number	Type	Bush	Bush Max. Bore	E ☆	K	L Length Thru Bore	M ☆	Wt. Less Bush	
	A Belts	B Belts																			
3 B 34 SH	3.0	3.4	3.75	E-1	SH	1 1/16	1 3/8	0	1 1/8	3/8	3.4	4 B 34 SD	E-1	SD	2	2 3/8	3/8	1 1/8	1 1/8	4.0	
3 B 36 SH	3.2	3.6	3.95	E-1	SH	1 1/16	3/8	3/8	1 1/8	1 1/8	3.8	4 B 36 SD	E-1	SD	2	2 3/8	3/8	1 1/8	1 1/8	5.0	
3 B 38 SH	3.4	3.8	4.15	E-1	SH	1 1/16	3/8	3/8	1 1/8	1 1/8	4.0	4 B 38 SD	E-1	SD	2	2 3/8	3/8	1 1/8	1 1/8	5.5	
3 B 40 SH	3.6	4.0	4.35	A-1	SH	1 1/16	1/2	1 1/8	1 1/8	1 1/8	4.5	4 B 40 SD	E-1	SD	2	2 1/2	0	1 1/8	3/8	6.0	
3 B 42 SH	3.8	4.2	4.55	A-1	SH	1 1/16	1/2	1 1/8	1 1/8	1 1/8	5.0	4 B 42 SD	E-1	SD	2	2 1/2	0	1 1/8	3/8	7.0	
3 B 44 SH	4.0	4.4	4.75	A-1	SH	1 1/16	1/2	1 1/8	1 1/8	1 1/8	5.5	4 B 44 SD	E-1	SD	2	2 1/2	0	1 1/8	3/8	7.3	
3 B 46 SD	4.2	4.6	4.95	A-1	SD	2	3/8	1 1/8	1 1/8	1/4	6.0	4 B 46 SD	A-1	SD	2	1 1/2	1 1/8	1 1/8	3/8	7.6	
3 B 48 SD	4.4	4.8	5.15	A-1	SD	2	3/8	1 1/8	1 1/8	1/4	6.5	4 B 48 SD	A-1	SD	2	1 1/2	1 1/8	1 1/8	3/8	8.0	
3 B 50 SD	4.6	5.0	5.35	A-1	SD	2	3/8	1 1/8	1 1/8	1/4	7.0	4 B 50 SD	A-1	SD	2	1 1/2	1 1/8	1 1/8	3/8	9.0	
3 B 52 SD	4.8	5.2	5.55	A-1	SD	2	3/8	1 1/8	1 1/8	1/4	8.0	4 B 52 SD	A-1	SD	2	1 1/2	1 1/8	1 1/8	3/8	10.0	
3 B 54 SD	5.0	5.4	5.75	A-1	SD	2	3/8	1 1/8	1 1/8	1/4	8.5	4 B 54 SD	A-1	SD	2	1 1/2	1 1/8	1 1/8	3/8	10.5	
3 B 56 SD	5.2	5.6	5.95	A-1	SD	2	3/8	1 1/8	1 1/8	1/4	9.0	4 B 56 SD	A-1	SD	2	1 1/2	1 1/8	1 1/8	3/8	11.0	
3 B 58 SD	5.4	5.8	6.15	A-1	SD	2	3/8	1 1/8	1 1/8	1/4	10.0	4 B 58 SD	A-1	SD	2	1 1/2	1 1/8	1 1/8	3/8	12.0	
3 B 60 SD	5.6	6.0	6.35	A-1	SD	2	3/8	1 1/8	1 1/8	1/4	11.0	4 B 60 SD	A-1	SD	2	1 1/2	1 1/8	1 1/8	3/8	12.5	
3 B 62 SD	5.8	6.2	6.55	A-1	SD	2	3/8	1 1/8	1 1/8	1/4	12.0	4 B 62 SD	A-1	SD	2	1 1/2	1 1/8	1 1/8	3/8	13.0	
3 B 64 SD	6.0	6.4	6.75	A-1	SD	2	3/8	1 1/8	1 1/8	1/4	12.3	4 B 64 SD	A-1	SD	2	1 1/2	1 1/8	1 1/8	3/8	14.0	
3 B 66 SD	6.2	6.6	6.95	A-1	SD	2	3/8	1 1/8	1 1/8	1/4	12.6	4 B 66 SD	A-1	SD	2	1 1/2	1 1/8	1 1/8	3/8	14.5	
3 B 68 SD	6.4	6.8	7.15	A-1	SD	2	3/8	1 1/8	1 1/8	1/4	13.0	4 B 68 SD	A-1	SD	2	1 1/2	1 1/8	1 1/8	3/8	15.0	
3 B 70 SK	6.6	7.0	7.35	A-1	SK	2 3/8	0	1 1/8	1 1/8	3/8	14.0	4 B 70 SK	A-1	SK	2 3/8	3/8	1	1 1/8	1	15.5	
3 B 74 SK	7.0	7.4	7.75	A-1	SK	2 3/8	0	1 1/8	1 1/8	3/8	15.0	4 B 74 SK	A-1	SK	2 3/8	3/8	1	1 1/8	1	16.0	
3 B 80 SK	7.6	8.0	8.35	A-1	SK	2 3/8	0	1 1/8	1 1/8	3/8	16.0	4 B 80 SK	A-1	SK	2 3/8	3/8	1	1 1/8	1	17.0	
3 B 86 SK	8.2	8.6	8.95	A-3	SK	2 3/8	0	1 1/8	1 1/8	3/8	17.0	4 B 86 SK	A-3	SK	2 3/8	3/8	1	1 1/8	1	18.0	
3 B 94 SK	9.0	9.4	9.75	A-3	SK	2 3/8	0	1 1/8	1 1/8	3/8	18.0	4 B 94 SK	A-3	SK	2 3/8	3/8	1	1 1/8	1	19.0	
3 B 110 SK	10.6	11.0	11.35	A-3	SK	2 3/8	0	1 1/8	1 1/8	3/8	19.0	4 B 110 SK	A-3	SK	2 3/8	3/8	1	1 1/8	1	24.0	
3 B 124 SK	12.0	12.4	12.75	A-3	SK	2 3/8	0	1 1/8	1 1/8	3/8	23.0	4 B 124 SK	A-3	SK	2 3/8	3/8	1	1 1/8	1	26.0	
3 B 136 SK	13.2	13.6	13.95	A-3	SK	2 3/8	0	1 1/8	1 1/8	3/8	24.1	4 B 136 SK	A-3	SK	2 3/8	3/8	1	1 1/8	1	28.0	
3 B 154 SK	15.0	15.4	15.75	A-3	SK	2 3/8	0	1 1/8	1 1/8	3/8	28.0	4 B 154 SF	A-3	SF	2 1/2	3/8	1	2 1/4	3/8	41.0	
3 B 160 SK	15.6	16.0	16.35	A-3	SK	2 3/8	0	1 1/8	1 1/8	3/8	29.0	4 B 160 SF	A-3	SF	2 1/2	3/8	1	2 1/4	3/8	42.0	
3 B 184 SK	18.0	18.4	18.75	A-3	SK	2 3/8	0	1 1/8	1 1/8	3/8	37.0	4 B 184 SF	A-3	SF	2 1/2	3/8	1	2 1/4	3/8	48.0	
3 B 200 SF	19.6	20.0	20.35	D-3	SF	2 1/2	3/8	3/8	2 1/4	1/2	39.0	4 B 200 SF	A-3	SF	2 1/2	3/8	1	2 1/4	3/8	58.0	
3 B 250 SF	24.6	25.0	25.35	D-3	SF	2 1/2	3/8	3/8	2 1/4	1/2	67.0	4 B 250 E	A-3	E	3 1/2	3/8	1	2 3/4	1/2	78.0	
3 B 300 SF	29.6	30.0	30.35	D-3	SF	2 1/2	3/8	3/8	2 1/4	1/2	74.0	4 B 300 E	A-3	E	3 1/2	3/8	1	2 3/4	1/2	93.0	
3 B 380 E	37.6	38.0	38.35	D-3	E	3 1/2	3/8	3/8	2 3/4	1/2	122.0	4 B 380 E	A-3	E	3 1/2	3/8	1	2 3/4	1/2	138.0	

NOTE: Dimensions in inches, weight in pounds. Weights do not include bushings. See page B-3 and B-4 for additional bushing dimensions.
 ☆ E and M dimensions are nominal and will vary depending on shaft tolerances. Type E sheaves are drilled for reverse mounting only.

PLEASE NOTE: Dashes are REQUIRED in place of spaces when ordering or searching on PTplace.com.

V-Belt | QD Sheaves



A

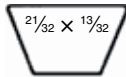

B

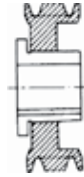

1 = SOLID

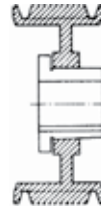

2 = WEB

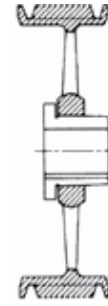

3 = ARM/SPOKE

QD Sheaves — A-B

Nomenclature Example: **5-B-34-SD**

5 Groove F = 4											6 Groove F = 4 1/4										
Part Number	PD		OD	Type	Bush	Bush Max. Bore	E ☆	K	L Length Thru Bore		Wt. Less Bush	Part Number	Type	Bush	Bush Max. Bore	E ☆	K	L Length Thru Bore		Wt. Less Bush	
	A Belts	B Belts							M ☆	M ☆								M ☆	M ☆		
5 B 34 SD	3.0	3.4	3.75	E-1	SD	2	3 3/4	7/16	1 1/16	1 1/16	5.0	6 B 34 SD	E-1	SD	2	3 3/4	5/16	1 1/16	1 1/16	6.0	
5 B 36 SD	3.2	3.6	3.95	E-1	SD	2	3 3/4	7/16	1 1/16	1 1/16	6.0	6 B 36 SD	E-1	SD	2	3 3/4	5/16	1 1/16	1 1/16	7.0	
5 B 38 SD	3.4	3.8	4.15	E-1	SD	2	3 3/4	7/16	1 1/16	1 1/16	6.5	6 B 38 SD	E-1	SD	2	3 3/4	5/16	1 1/16	1 1/16	7.5	
5 B 40 SD	3.6	4.0	4.35	E-1	SD	2	2 1/2	0	1 1/16	5/8	7.0	6 B 40 SD	E-1	SD	2	3 3/4	0	1 1/16	5/8	8.0	
5 B 42 SD	3.8	4.2	4.55	E-1	SD	2	2 1/2	0	1 1/16	5/8	7.5	6 B 42 SD	E-1	SD	2	3 3/4	0	1 1/16	5/8	9.0	
5 B 44 SD	4.0	4.4	4.75	E-1	SD	2	2 1/2	0	1 1/16	5/8	8.0	6 B 44 SD	E-1	SD	2	3 3/4	0	1 1/16	5/8	9.5	
5 B 46 SD	4.2	4.6	4.95	A-1	SD	2	1 1/2	1 1/16	1 1/16	1 1/2	9.0	6 B 46 SD	A-1	SD	2	2 1/2	1 1/16	1 1/16	2 3/8	10.0	
5 B 48 SD	4.4	4.8	5.15	A-1	SD	2	1 1/2	1 1/16	1 1/16	1 1/2	9.5	6 B 48 SD	A-1	SD	2	2 1/2	1 1/16	1 1/16	2 3/8	10.5	
5 B 50 SD	4.6	5.0	5.35	A-1	SD	2	1 1/2	1 1/16	1 1/16	1 1/2	10.0	6 B 50 SD	A-1	SD	2	2 1/2	1 1/16	1 1/16	2 3/8	11.0	
5 B 52 SD	4.8	5.2	5.55	A-1	SD	2	1 1/2	1 1/16	1 1/16	1 1/2	10.5	6 B 52 SD	A-1	SD	2	2 1/2	1 1/16	1 1/16	2 3/8	11.5	
5 B 54 SK	5.0	5.4	5.75	A-1	SK	2 3/8	5/8	1 1/16	1 1/16	1 1/2	11.0	6 B 54 SK	A-1	SK	2 3/8	5/8	1 1/16	1 1/16	2 3/8	12.0	
5 B 56 SK	5.2	5.6	5.95	A-1	SK	2 3/8	5/8	1 1/16	1 1/16	1 1/2	11.5	6 B 56 SK	A-1	SK	2 3/8	5/8	1 1/16	1 1/16	2 3/8	13.0	
5 B 58 SK	5.4	5.8	6.15	A-1	SK	2 3/8	5/8	1 1/16	1 1/16	1 1/2	12.0	6 B 58 SK	A-1	SK	2 3/8	5/8	1 1/16	1 1/16	2 3/8	14.0	
5 B 60 SK	5.6	6.0	6.35	A-1	SK	2 3/8	5/8	1 1/16	1 1/16	1 1/2	13.0	6 B 60 SK	A-1	SK	2 3/8	5/8	1 1/16	1 1/16	2 3/8	15.0	
5 B 62 SK	5.8	6.2	6.55	A-1	SK	2 3/8	5/8	1 1/16	1 1/16	1 1/2	14.0	6 B 62 SK	A-1	SK	2 3/8	5/8	1 1/16	1 1/16	2 3/8	16.0	
5 B 64 SK	6.0	6.4	6.75	A-1	SK	2 3/8	5/8	1 1/16	1 1/16	1 1/2	15.0	6 B 64 SK	A-1	SK	2 3/8	5/8	1 1/16	1 1/16	2 3/8	17.0	
5 B 66 SK	6.2	6.6	6.95	A-1	SK	2 3/8	5/8	1 1/16	1 1/16	1 1/2	16.0	6 B 66 SK	A-1	SK	2 3/8	5/8	1 1/16	1 1/16	2 3/8	18.0	
5 B 68 SK	6.4	6.8	7.15	A-1	SK	2 3/8	5/8	1 1/16	1 1/16	1 1/2	17.0	6 B 68 SK	A-1	SK	2 3/8	5/8	1 1/16	1 1/16	2 3/8	19.0	
5 B 70 SF	6.6	7.0	7.35	A-1	SF	2 1/2	5/8	1 1/16	2 1/16	1 1/2	18.0	6 B 70 SF	A-1	SF	2 1/2	1	1 1/16	2 1/16	1 1/2	19.5	
5 B 74 SF	7.0	7.4	7.75	A-1	SF	2 1/2	5/8	1 1/16	2 1/16	1 1/2	20.0	6 B 74 SF	A-1	SF	2 1/2	1	1 1/16	2 1/16	1 1/2	22.0	
5 B 80 SF	7.6	8.0	8.35	A-1	SF	2 1/2	5/8	1 1/16	2 1/16	1 1/2	23.0	6 B 80 SF	A-1	SF	2 1/2	1	1 1/16	2 1/16	1 1/2	25.0	
5 B 86 SF	8.2	8.6	8.95	A-2	SF	2 1/2	5/8	1 1/16	2 1/16	1 1/2	24.0	6 B 86 SF	A-2	SF	2 1/2	1	1 1/16	2 1/16	1 1/2	28.0	
5 B 94 SF	9.0	9.4	9.75	A-2	SF	2 1/2	5/8	1 1/16	2 1/16	1 1/2	26.0	6 B 94 SF	A-2	SF	2 1/2	1	1 1/16	2 1/16	1 1/2	29.0	
5 B 110 SF	10.6	11.0	11.35	A-2	SF	2 1/2	5/8	1 1/16	2 1/16	1 1/2	32.0	6 B 110 SF	A-2	SF	2 1/2	1	1 1/16	2 1/16	1 1/2	30.0	
5 B 124 SF	12.0	12.4	12.75	A-3	SF	2 1/2	5/8	1 1/16	2 1/16	1 1/2	35.0	6 B 124 SF	A-3	SF	2 1/2	1	1 1/16	2 1/16	1 1/2	40.0	
5 B 136 SF	13.2	13.6	13.95	A-3	SF	2 1/2	5/8	1 1/16	2 1/16	1 1/2	36.0	6 B 136 SF	A-3	SF	2 1/2	1	1 1/16	2 1/16	1 1/2	45.0	
5 B 154 SF	15.0	15.4	15.75	A-3	SF	2 1/2	5/8	1 1/16	2 1/16	1 1/2	46.0	6 B 154 SF	A-3	SF	2 1/2	1	1 1/16	2 1/16	1 1/2	46.0	
5 B 160 SF	15.6	16.0	16.35	A-3	SF	2 1/2	5/8	1 1/16	2 1/16	1 1/2	48.0	6 B 160 SF	A-3	SF	2 1/2	1	1 1/16	2 1/16	1 1/2	50.0	
5 B 184 SF	18.0	18.4	18.75	A-3	SF	2 1/2	5/8	1 1/16	2 1/16	1 1/2	50.0	6 B 184 SF	A-3	SF	2 1/2	1	1 1/16	2 1/16	1 1/2	60.0	
5 B 200 E	19.6	20.0	20.35	A-3	E	3 1/2	5/8	1 1/4	2 3/8	1	72.0	6 B 200 E	A-3	E	3 1/2	1/2	1 1/8	2 3/8	1 1/2	78.0	
5 B 250 E	24.6	25.0	25.35	A-3	E	3 1/2	5/8	1 1/4	2 3/8	1	90.0	6 B 250 E	A-3	E	3 1/2	1/2	1 1/8	2 3/8	1 1/2	98.0	
5 B 300 E	29.6	30.0	30.35	A-3	E	3 1/2	5/8	1 1/4	2 3/8	1	108.0	6 B 300 E	A-3	E	3 1/2	1/2	1 1/8	2 3/8	1 1/2	109.0	
5 B 380 E	37.6	38.0	38.35	A-3	E	3 1/2	5/8	1 1/4	2 3/8	1	145.0	6 B 380 E	A-3	E	3 1/2	1/2	1 1/8	2 3/8	1 1/2	173.0	

NOTE: Dimensions in inches, weight in pounds. Weights do not include bushings. See page B-3 and B-4 for additional bushing dimensions.
 ☆ E and M dimensions are nominal and will vary depending on shaft tolerances. Type E sheaves are drilled for reverse mounting only.

PLEASE NOTE: Dashes are REQUIRED in place of spaces when ordering or searching on PTplace.com.

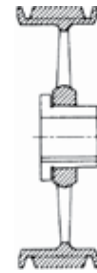
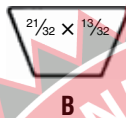
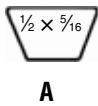
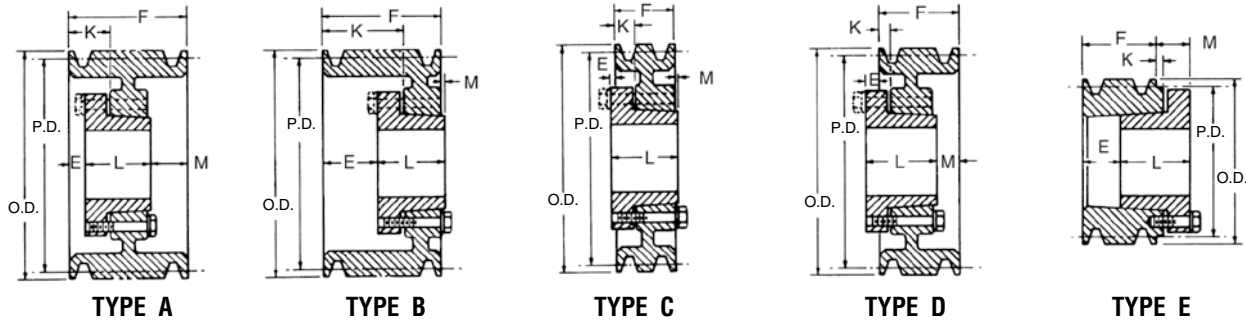

QD Sheaves — A-B

Nomenclature Example: **8-B-54-SK**

8 Groove F = 6 1/4													10 Groove F = 7 3/4												
Part Number	PD		OD	Type	Bush	Bush Max. Bore	E ☆	K	L Length Thru Bore	M ☆	Wt. Less Bush	Part Number	Type	Bush	Bush Max. Bore	E ☆	K	L Length Thru Bore	M ☆	Wt. Less Bush					
	A Belts	B Belts																							
8 B 54 SK	5.0	5.4	5.75	A-1	SK	2 1/8	1 1/8	1 1/8	1 1/8	3 3/8	14.0	10 B 54 SK	A-1	SK	2 1/8	1 1/8	2 1/8	1 1/8	3 3/8	15.0					
8 B 56 SK	5.2	5.6	5.95	A-1	SK	2 1/8	1 1/8	1 1/8	1 1/8	3 3/8	16.0	10 B 56 SK	A-1	SK	2 1/8	1 1/8	2 1/8	1 1/8	3 3/8	18.0					
8 B 58 SK	5.4	5.8	6.15	A-1	SK	2 1/8	1 1/8	1 1/8	1 1/8	3 3/8	16.5	10 B 58 SK	A-1	SK	2 1/8	1 1/8	2 1/8	1 1/8	3 3/8	20.0					
8 B 60 SF	5.6	6.0	6.35	A-1	SF	2 1/8	1 1/8	1 1/8	2 1/8	3 3/8	17.0	10 B 60 SF	A-1	SF	2 1/8	1 1/8	2 1/8	2 1/8	3 3/8	22.0					
8 B 62 SF	5.8	6.2	6.55	A-1	SF	2 1/8	1 1/8	1 1/8	2 1/8	3 3/8	18.0	10 B 62 SF	A-1	SF	2 1/8	1 1/8	2 1/8	2 1/8	3 3/8	24.0					
8 B 64 SF	6.0	6.4	6.75	A-1	SF	2 1/8	1 1/8	1 1/8	2 1/8	3 3/8	18.5	10 B 64 SF	A-1	SF	2 1/8	1 1/8	2 1/8	2 1/8	3 3/8	25.0					
8 B 66 SF	6.2	6.6	6.95	A-1	SF	2 1/8	1 1/8	1 1/8	2 1/8	3 3/8	21.0	10 B 66 SF	A-1	SF	2 1/8	1 1/8	2 1/8	2 1/8	3 3/8	26.0					
8 B 68 SF	6.4	6.8	7.15	A-1	SF	2 1/8	1 1/8	1 1/8	2 1/8	3 3/8	22.0	10 B 68 SF	A-1	SF	2 1/8	1 1/8	2 1/8	2 1/8	3 3/8	27.0					
8 B 70 SF	6.6	7.0	7.35	A-1	SF	2 1/8	1 1/8	1 1/8	2 1/8	3 3/8	22.5	10 B 70 SF	A-1	SF	2 1/8	1 1/8	2 1/8	2 1/8	3 3/8	28.0					
8 B 74 SF	7.0	7.4	7.75	A-1	SF	2 1/8	1 1/8	1 1/8	2 1/8	3 3/8	25.0	10 B 74 SF	A-1	SF	2 1/8	1 1/8	2 1/8	2 1/8	3 3/8	31.0					
8 B 80 SF	7.6	8.0	8.35	A-1	SF	2 1/8	1 1/8	1 1/8	2 1/8	3 3/8	29.0	10 B 80 SF	A-1	SF	2 1/8	1 1/8	2 1/8	2 1/8	3 3/8	35.0					
8 B 86 E	8.2	8.6	8.95	A-1	E	3 1/2	1 1/2	2 1/2	2 1/2	2 1/2	34.0	10 B 86 E	A-1	E	3 1/2	2 1/2	3 1/2	2 1/2	2 1/2	38.0					
8 B 94 E	9.0	9.4	9.75	A-1	E	3 1/2	1 1/2	2 1/2	2 1/2	2 1/2	40.0	10 B 94 E	A-1	E	3 1/2	2 1/2	3 1/2	2 1/2	2 1/2	45.0					
8 B 110 E	10.6	11.0	11.35	A-2	E	3 1/2	1 1/2	2 1/2	2 1/2	2 1/2	47.0	10 B 110 E	A-2	E	3 1/2	2 1/2	3 1/2	2 1/2	2 1/2	53.0					
8 B 124 E	12.0	12.4	12.75	A-3	E	3 1/2	1 1/2	2 1/2	2 1/2	2 1/2	52.0	10 B 124 E	A-3	E	3 1/2	2 1/2	3 1/2	2 1/2	2 1/2	63.0					
8 B 136 E	13.2	13.6	13.95	A-3	E	3 1/2	1 1/2	2 1/2	2 1/2	2 1/2	60.0	10 B 136 F	A-3	F	3 3/8	1 1/8	2 1/8	3 1/8	3 3/8	78.0					
8 B 154 E	15.0	15.4	15.75	A-3	E	3 1/2	1 1/2	2 1/2	2 1/2	2 1/2	82.0	10 B 154 F	A-3	F	3 3/8	1 1/8	2 1/8	3 1/8	3 3/8	90.0					
8 B 160 E	15.6	16.0	16.35	A-3	E	3 1/2	1 1/2	2 1/2	2 1/2	2 1/2	90.0	10 B 160 F	A-3	F	3 3/8	1 1/8	2 1/8	3 1/8	3 3/8	96.0					
8 B 184 F	18.0	18.4	18.75	A-3	F	3 3/8	1 1/8	2 1/8	3 1/8	2 1/8	110.0	10 B 184 F	A-3	F	3 3/8	1 1/8	2 1/8	3 1/8	3 3/8	113.0					
8 B 200 F	19.6	20.0	20.35	A-3	F	3 3/8	1 1/8	2 1/8	3 1/8	2 1/8	122.0	10 B 200 F	A-3	F	3 3/8	1 1/8	2 1/8	3 1/8	3 3/8	114.0					
8 B 250 F	24.6	25.0	25.35	A-3	F	3 3/8	1 1/8	2 1/8	3 1/8	2 1/8	138.0	10 B 250 F	A-3	F	3 3/8	1 1/8	2 1/8	3 1/8	3 3/8	138.0					
8 B 300 F	29.6	30.0	30.35	A-3	F	3 3/8	1 1/8	2 1/8	3 1/8	2 1/8	168.0	10 B 300 F	A-3	F	3 3/8	1 1/8	2 1/8	3 1/8	3 3/8	200.0					
8 B 380 F	37.6	38.0	38.35	A-3	F	3 3/8	1 1/8	2 1/8	3 1/8	2 1/8	222.0	10 B 380 J	A-3	J	4 1/2	1 1/2	1 1/2	4 1/2	2 1/2	279.0					

NOTE: Dimensions in inches, weight in pounds. Weights do not include bushings. See page B-3 and B-4 for additional bushing dimensions.
 ☆ E and M dimensions are nominal and will vary depending on shaft tolerances. Type E sheaves are drilled for reverse mounting only.

PLEASE NOTE: Dashes are REQUIRED in place of spaces when ordering or searching on PTplace.com.

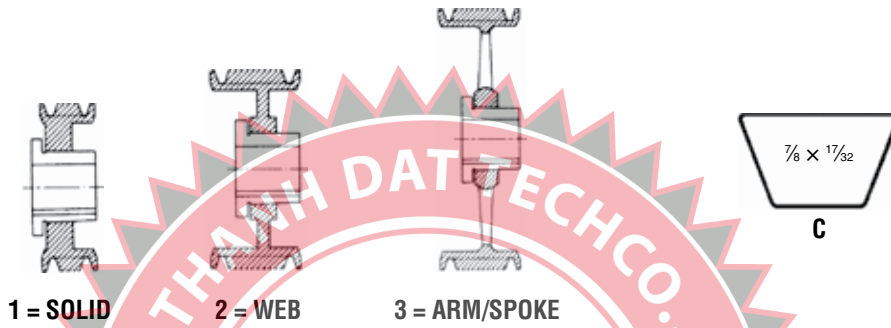
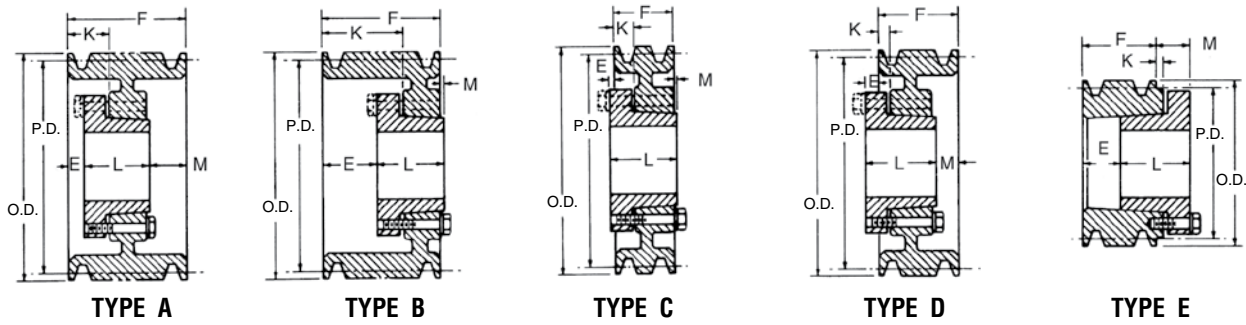

QD Sheaves — C

Nomenclature Example: 1-C-60-SK

1 Groove F = 1 3/8										2 Groove F = 2 3/8									
Part Number	PD C Belt	OD	Type	Bush Max. Bore	E ☆	K	L		Wt. Less Bush	Part Number	Type	Bush Max. Bore	E ☆	K	L		Wt. Less Bush		
							Thru Bore	M ☆							Thru Bore	M ☆			
1 C 60 SK	6.00	6.40	C-1	SK	2 5/16	5/16	1/8	1 1/16	0	9.4	2 C 60 SF	A-1	SF	2 5/16	5/16	7/8	2 1/16	1/8	8.0
1 C 70 SF	7.00	7.40	C-1	SF	2 5/16	5/16	1/8	2 1/16	1/8	9.8	2 C 70 SF	A-1	SF	2 5/16	5/16	13/16	2 1/16	3/16	12.0
1 C 75 SF	7.50	7.90	C-1	SF	2 5/16	5/16	1/8	2 1/16	1/8	11.0	2 C 75 SF	A-1	SF	2 5/16	5/16	13/16	2 1/16	3/16	15.0
1 C 80 SF	8.00	8.40	C-1	SF	2 5/16	5/16	1/8	2 1/16	1/8	13.0	2 C 80 SF	A-1	SF	2 5/16	5/16	13/16	2 1/16	3/16	16.0
1 C 85 SF	8.50	8.90	C-1	SF	2 5/16	5/16	1/8	2 1/16	1/8	13.3	2 C 85 SF	A-1	SF	2 5/16	5/16	13/16	2 1/16	3/16	19.0
1 C 90 SF	9.00	9.40	C-3	SF	2 5/16	5/16	1/8	2 1/16	1/8	13.5	2 C 90 SF	A-2	SF	2 5/16	5/16	13/16	2 1/16	3/16	19.5
1 C 95 SF	9.50	9.90	C-3	SF	2 5/16	5/16	1/8	2 1/16	1/8	13.8	2 C 95 SF	A-2	SF	2 5/16	5/16	13/16	2 1/16	3/16	21.0
1 C 100 SF	10.00	10.40	C-3	SF	2 5/16	5/16	1/8	2 1/16	1/8	14.0	2 C 100 SF	A-2	SF	2 5/16	5/16	13/16	2 1/16	3/16	22.0
1 C 105 SF	10.50	10.90	C-3	SF	2 5/16	5/16	1/8	2 1/16	1/8	15.0	2 C 105 SF	A-2	SF	2 5/16	5/16	13/16	2 1/16	3/16	25.0
1 C 110 SF	11.00	11.40	C-3	SF	2 5/16	5/16	1/8	2 1/16	1/8	15.8	2 C 110 SF	A-3	SF	2 5/16	5/16	13/16	2 1/16	3/16	26.0
1 C 120 SF	12.00	12.40	C-3	SF	2 5/16	5/16	1/8	2 1/16	1/8	17.0	2 C 120 SF	D-3	SF	2 5/16	5/16	5/8	2 1/16	7/16	29.0
1 C 130 SF	13.00	13.40	C-3	SF	2 5/16	5/16	1/8	2 1/16	1/8	18.0	2 C 130 SF	D-3	SF	2 5/16	5/16	5/8	2 1/16	7/16	31.0
1 C 140 SF	14.00	14.40	C-3	SF	2 5/16	5/16	1/8	2 1/16	1/8	20.0	2 C 140 SF	D-3	SF	2 5/16	5/16	5/8	2 1/16	7/16	35.0
1 C 150 SF	15.00	15.40	C-3	SF	2 5/16	5/16	1/8	2 1/16	1/8	21.0	2 C 150 SF	D-3	SF	2 5/16	5/16	5/8	2 1/16	7/16	39.0
1 C 160 SF	16.00	16.40	C-3	SF	2 5/16	5/16	1/8	2 1/16	1/8	24.0	2 C 160 SF	D-3	SF	2 5/16	5/16	5/8	2 1/16	7/16	43.0
1 C 180 SF	18.00	18.40	C-3	SF	2 5/16	5/16	1/8	2 1/16	1/8	27.0	2 C 180 SF	D-3	SF	2 5/16	5/16	5/8	2 1/16	7/16	48.0
1 C 200 SF	20.00	20.40	C-3	SF	2 5/16	5/16	1/8	2 1/16	1/8	31.0	2 C 200 SF	D-3	SF	2 5/16	5/16	5/8	2 1/16	7/16	55.0
1 C 240 SF	24.00	24.40	C-3	SF	2 5/16	5/16	1/8	2 1/16	1/8	37.0	2 C 240 SF	D-3	SF	2 5/16	5/16	5/8	2 1/16	7/16	65.0
	27.00	27.40									2 C 270 F	C-3	F	3 5/16	1 1/16	3/8	3 3/8	3/16	107.0
	30.00	30.40									2 C 300 F	C-3	F	3 5/16	1 1/16	5/8	3 3/8	3/16	115.0

☆ E and M dimensions are nominal and will vary depending on shaft tolerances. Type E sheaves are drilled for reverse mounting only. See page B-3 and B-4 for additional bushing dimensions.

PLEASE NOTE: Dashes are REQUIRED in place of spaces when ordering or searching on PTplace.com.

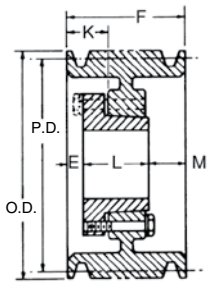

TYPE A

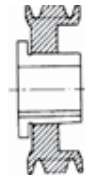

1 = SOLID

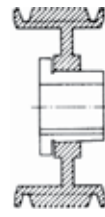

2 = WEB

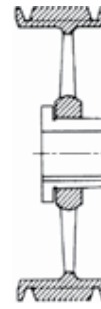

3 = ARM/SPOKE

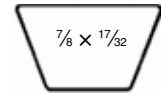

C

QD Sheaves — C

Nomenclature Example: 3-C-50-SD

3 Groove F = 3 3/8"												4 Groove F = 4 3/8"											
Part Number	PD C Belt	OD	Type	Bush	Bush Max. Bore	E ☆	K	L Length Thru Bore		Wt. Less Bush	Part Number	Type	Bush	Bush Max. Bore	E ☆	K	L Length Thru Bore		Wt. Less Bush				
								M ☆	M ☆								M ☆	M ☆					
3 C 50 SD	5.00	5.40	A-1	SD	2	3/8	1 1/4	1 1/4	1 1/4	8.0	4 C 50 SD	A-1	SD	2	3/8	1 1/4	1 1/4	1 1/4	10.0				
3 C 54 SD	5.40	5.80	A-1	SD	2	1/2	1 1/4	1 1/4	1 1/4	9.0	4 C 54 SD	A-1	SD	2	1/2	1 1/4	1 1/4	1 1/4	12.0				
3 C 55 SD	5.50	5.90	A-1	SD	2	1/2	1 1/4	1 1/4	1 1/4	10.0	4 C 55 SD	A-1	SD	2	1/2	1 1/4	1 1/4	1 1/4	12.4				
3 C 56 SD	5.60	6.00	A-1	SD	2	1/2	1 1/4	1 1/4	1 1/4	11.0	4 C 56 SD	A-1	SD	2	1/2	1 1/4	1 1/4	1 1/4	12.4				
3 C 60 SF	6.00	6.40	A-1	SF	2 1/2	3/8	1 1/4	2 1/4	1 1/4	12.0	4 C 60 SF	A-1	SF	2 1/2	3/8	1 1/4	2 1/4	2 1/4	12.6				
3 C 70 SF	7.00	7.40	A-1	SF	2 1/2	3/8	1 1/4	2 1/4	1 1/4	14.0	4 C 70 SF	A-2	SF	2 1/2	3/8	1 1/4	2 1/4	1 1/4	13.0				
3 C 75 SF	7.50	7.90	A-1	SF	2 1/2	3/8	1 1/4	2 1/4	1 1/4	17.0	4 C 75 SF	A-2	SF	2 1/2	3/8	1 1/4	2 1/4	1 1/4	19.0				
3 C 80 E	8.00	8.40	B-1	E	3 1/2	7/8	1 1/4	2 1/4	1 1/4	19.0	4 C 80 E	A-2	E	3 1/2	1 1/4	2	2 1/4	3/4	24.0				
3 C 85 E	8.50	8.90	B-1	E	3 1/2	7/8	1 1/4	2 1/4	1 1/4	22.0	4 C 85 E	A-1	E	3 1/2	1 1/4	2	2 1/4	3/4	27.0				
3 C 90 E	9.00	9.40	B-1	E	3 1/2	7/8	1 1/4	2 1/4	1 1/4	26.0	4 C 90 E	A-1	E	3 1/2	1 1/4	2	2 1/4	3/4	30.0				
3 C 95 E	9.50	9.90	B-1	E	3 1/2	7/8	1 1/4	2 1/4	1 1/4	29.0	4 C 95 E	A-1	E	3 1/2	1 1/4	2	2 1/4	3/4	33.0				
3 C 100 E	10.00	10.40	B-1	E	3 1/2	7/8	1 1/4	2 1/4	1 1/4	27.0	4 C 100 E	A-1	E	3 1/2	1 1/4	2	2 1/4	3/4	35.0				
3 C 105 E	10.50	10.90	B-2	E	3 1/2	7/8	1 1/4	2 1/4	1 1/4	31.0	4 C 105 E	A-2	E	3 1/2	1 1/4	2	2 1/4	3/4	40.0				
3 C 110 E	11.00	11.40	B-2	E	3 1/2	7/8	1 1/4	2 1/4	1 1/4	38.0	4 C 110 E	A-1	E	3 1/2	1 1/4	2	2 1/4	3/4	45.0				
3 C 120 E	12.00	12.40	B-3	E	3 1/2	7/8	1 1/4	2 1/4	1 1/4	40.0	4 C 120 E	A-1	E	3 1/2	1 1/4	2	2 1/4	3/4	48.0				
3 C 130 E	13.00	13.40	B-3	E	3 1/2	7/8	1 1/4	2 1/4	1 1/4	43.0	4 C 130 E	A-3	E	3 1/2	1 1/4	2	2 1/4	3/4	49.0				
3 C 140 E	14.00	14.40	B-3	E	3 1/2	7/8	1 1/4	2 1/4	1 1/4	46.0	4 C 140 E	A-3	E	3 1/2	1 1/4	2	2 1/4	3/4	56.0				
3 C 150 E	15.00	15.40	B-3	E	3 1/2	7/8	1 1/4	2 1/4	1 1/4	52.0	4 C 150 E	A-3	E	3 1/2	1 1/4	2	2 1/4	3/4	62.0				
3 C 160 E	16.00	16.40	B-3	E	3 1/2	7/8	1 1/4	2 1/4	1 1/4	58.0	4 C 160 E	A-3	E	3 1/2	1 1/4	2	2 1/4	3/4	68.0				
3 C 180 E	18.00	18.40	B-3	E	3 1/2	7/8	1 1/4	2 1/4	1 1/4	67.0	4 C 180 E	A-3	E	3 1/2	1 1/4	2	2 1/4	3/4	74.0				
3 C 200 E	20.00	20.40	A-3	E	3 1/2	7/8	1	2 1/4	3/4	70.0	4 C 200 E	A-3	E	3 1/2	3/8	1 1/2	2 1/4	1 1/2	81.0				
3 C 240 E	24.00	24.40	A-3	F	3 1/2	7/8	1	2 1/4	3/4	90.0	4 C 240 F	A-3	F	3 1/2	3/8	1 1/2	3 1/4	7/8	120.0				
3 C 270 F	27.00	27.40	C-3	F	3 1/2	7/8	1 1/4	3 1/4	3/4	124.0	4 C 270 F	A-3	F	3 1/2	3/8	1 1/2	3 1/4	7/8	138.0				
3 C 300 F	30.00	30.40	C-3	F	3 1/2	7/8	1 1/4	3 1/4	3/4	130.0	4 C 300 F	A-3	F	3 1/2	3/8	1 1/2	3 1/4	7/8	166.0				
3 C 360 F	36.00	36.40	C-3	F	3 1/2	7/8	1 1/4	3 1/4	3/4	166.0	4 C 360 F	A-3	F	3 1/2	3/8	1 1/2	3 1/4	7/8	176.0				
3 C 440 F	44.00	44.40	C-3	F	3 1/2	7/8	1 1/4	3 1/4	3/4	208.0	4 C 440 J	B-3	J	4 1/2	3/8	1 1/2	4 1/2	1 1/2	254.0				
3 C 500 F	50.00	50.40	C-3	F	3 1/2	7/8	1 1/4	3 1/4	3/4	250.0	4 C 500 J	B-3	J	4 1/2	3/8	1 1/2	4 1/2	1 1/2	318.0				

5 Groove F = 5"												6 Groove F = 6"											
Part Number	PD C Belt	OD	Type	Bush	Bush Max. Bore	E ☆	K	L Length Thru Bore		Wt. Less Bush	Part Number	Type	Bush	Bush Max. Bore	E ☆	K	L Length Thru Bore		Wt. Less Bush				
								M ☆	M ☆								M ☆	M ☆					
5 C 60 SF	6.00	6.40	A-1	SF	2 1/2	3/8	1 1/4	2 1/4	3 1/4	14.0	6 C 60 SF	A-1	SF	2 1/2	3/8	1 1/4	2 1/4	4 1/4	16.0				
5 C 70 SF	7.00	7.40	A-1	SF	2 1/2	1/2	1 1/4	2 1/4	2 1/4	19.0	6 C 70 SF	A-1	SF	2 1/2	1/2	1 1/4	2 1/4	3 1/4	22.0				
5 C 75 SF	7.50	7.90	A-1	SF	2 1/2	1/2	1 1/4	2 1/4	2 1/4	22.0	6 C 75 SF	A-1	SF	2 1/2	1/2	1 1/4	2 1/4	3 1/4	25.0				
5 C 80 E	8.00	8.40	A-1	E	3 1/2	1 1/2	2 1/4	2 1/4	1 1/4	28.0	6 C 80 E	A-1	E	3 1/2	1 1/2	2 1/4	2 1/4	2 1/4	31.0				
5 C 85 E	8.50	8.90	A-1	E	3 1/2	1 1/2	2 1/4	2 1/4	1 1/4	31.0	6 C 85 E	A-1	E	3 1/2	1 1/2	2 1/4	2 1/4	2 1/4	35.0				
5 C 90 E	9.00	9.40	A-1	E	3 1/2	1 1/2	2 1/4	2 1/4	1 1/4	32.0	6 C 90 F	A-1	F	3 1/2	1 1/2	2 1/4	3 1/4	1 1/2	40.0				
5 C 95 E	9.50	9.90	A-1	E	3 1/2	1 1/2	2 1/4	2 1/4	1 1/4	36.0	6 C 95 F	A-1	F	3 1/2	1 1/2	2 1/4	3 1/4	1 1/2	44.0				
5 C 100 E	10.00	10.40	A-2	E	3 1/2	1 1/2	2 1/4	2 1/4	1 1/4	38.0	6 C 100 F	A-1	F	3 1/2	1 1/2	2 1/4	3 1/4	1 1/2	50.0				
5 C 105 E	10.50	10.90	A-2	E	3 1/2	1 1/2	2 1/4	2 1/4	1 1/4	43.0	6 C 105 F	A-1	F	3 1/2	1 1/2	2 1/4	3 1/4	1 1/2	56.0				
5 C 110 E	11.00	11.40	A-1	E	3 1/2	1 1/2	2 1/4	2 1/4	1 1/4	50.0	6 C 110 F	A-1	F	3 1/2	1 1/2	2 1/4	3 1/4	1 1/2	60.0				
5 C 120 E	12.00	12.40	A-1	E	3 1/2	1 1/2	2 1/4	2 1/4	1 1/4	55.0	6 C 120 F	A-1	F	3 1/2	1 1/2	2 1/4	3 1/4	1 1/2	65.0				
5 C 130 E	13.00	13.40	A-3	E	3 1/2	1 1/2	2 1/4	2 1/4	1 1/4	58.0	6 C 130 F	A-3	F	3 1/2	1 1/2	2 1/4	3 1/4	1 1/2	67.0				
5 C 140 E	14.00	14.40	A-3	E	3 1/2	1 1/2	2 1/4	2 1/4	1 1/4	61.0	6 C 140 F	A-3	F	3 1/2	1 1/2	2 1/4	3 1/4	1 1/2	75.0				
5 C 150 E	15.00	15.40	A-3	E	3 1/2	1 1/2	2 1/4	2 1/4	1 1/4	69.0	6 C 150 F	A-3	F	3 1/2	1 1/2	2 1/4	3 1/4	1 1/2	91.0				
5 C 160 E	16.00	16.40	A-3	E	3 1/2	1 1/2	2 1/4	2 1/4	1 1/4	75.0	6 C 160 F	A-3	F	3 1/2	1 1/2	2 1/4	3 1/4	1 1/2	93.0				
5 C 180 E	18.00	18.40	A-3	E	3 1/2	1 1/2	2 1/4	2 1/4	1 1/4	85.0	6 C 180 F	A-3	F	3 1/2	1 1/2	2 1/4	3 1/4	1 1/2	106.0				
5 C 200 F	20.00	20.40	A-3	F	3 1/2	5/8	1 1/2	3 1/4	1 1/2	108.0	6 C 200 F	A-3	F	3 1/2	5/8	1 1/2	3 1/4	1 1/2	125.0				
5 C 240 F	24.00	24.40	A-3	F	3 1/2	5/8	1 1/2	3 1/4	1 1/2	124.0	6 C 240 F	A-3	F	3 1/2	5/8	1 1/2	3 1/4	1 1/2	162.0				
5 C 270 F	27.00	27.40	A-3	F	3 1/2	5/8	1 1/2	3 1/4	1 1/2	154.0	6 C 270 J	A-3	J	3 1/2	3/8	1 1/2	4 1/2	1 1/2	190.0				
5 C 300 F	30.00	30.40	A-3	F	3 1/2	5/8	1 1/2	3 1/4	1 1/2	174.0	6 C 300 J	A-3	J	4 1/2	3/8	1 1/2	4 1/2	1 1/2	229.0				
5 C 360 J	36.00	36.40	A-3	J	4 1/2	3/8	1 1/2	4 1/2	1 1/2	226.0	6 C 360 J	A-3	J	4 1/2	3/8	1 1/2	4 1/2	1 1/2	270.0				
5 C 440 J	44.00	44.40	A-3	J	4 1/2	3/8	1 1/2	4 1/2	1 1/2	289.0	6 C 440 J	A-3	J	4 1/2	3/8	1 1/2	4 1/2	1 1/2	301.0				
5 C 500 J	50.00	50.40	A-3	J	4 1/2	3/8	1 1/2	4 1/2	1 1/2	316.0	6 C 500 M	B-3	M	5 1/2	3/8	1 1/2	6 1/4	7/8	444.0				

NOTE: Dimensions in inches, weight in pounds. Weights do not include bushings. See page B-3 and B-4 for additional bushing dimensions.
 ☆ E and M dimensions are nominal and will vary depending on shaft tolerances. Type E sheaves are drilled for reverse mounting only.

QD Sheaves — C

Nomenclature Example: **8-C-70-SF**

8 Groove F = 8%											10 Groove F = 10%								
Part Number	PD	OD	Type	Bush	Bush Max. Bore	E	K	L Length Thru Bore	M	Wt. Less Bush	Part Number	Type	Bush	Bush Max. Bore	E	K	L Length Thru Bore	M	Wt. Less Bush
	C Belt																		
8 C 70 SF	7.00	7.40	A-1	SF	2 ¹ / ₁₆	2 ¹ / ₁₆	3	2 ¹ / ₁₆	4	35.0	10 C 80 E	A-1	E	3 ¹ / ₂	2 ¹ / ₁₆	3 ¹ / ₄	2 ¹ / ₁₆	5 ¹ / ₁₆	42.8
8 C 80 E	8.00	8.40	A-1	E	3 ¹ / ₂	2 ¹ / ₁₆	3 ¹ / ₄	2 ¹ / ₁₆	3 ¹ / ₂	36.6	10 C 85 E	A-1	E	3 ¹ / ₂	2 ¹ / ₁₆	3 ¹ / ₄	2 ¹ / ₁₆	5 ¹ / ₁₆	48.5
8 C 85 E	8.50	8.90	A-1	E	3 ¹ / ₂	2 ¹ / ₁₆	3 ¹ / ₄	2 ¹ / ₁₆	3 ¹ / ₂	41.0	10 C 90 J	A-1	J	4 ¹ / ₂	2 ¹ / ₁₆	3 ¹ / ₁₆	4 ¹ / ₂	3 ¹ / ₂	54.0
8 C 90 F	9.00	9.40	A-1	F	3 ¹ / ₁₆	2 ¹ / ₁₆	3 ¹ / ₁₆	3 ¹ / ₁₆	2 ¹ / ₁₆	50.0	10 C 95 J	A-1	J	4 ¹ / ₂	2 ¹ / ₁₆	3 ¹ / ₁₆	4 ¹ / ₂	3 ¹ / ₂	60.0
8 C 95 F	9.50	9.90	A-1	F	3 ¹ / ₁₆	2 ¹ / ₁₆	3 ¹ / ₁₆	3 ¹ / ₁₆	2 ¹ / ₁₆	51.0	10 C 100 J	A-1	J	4 ¹ / ₂	2 ¹ / ₁₆	3 ¹ / ₁₆	4 ¹ / ₂	3 ¹ / ₂	68.0
8 C 100 F	10.00	10.40	A-1	F	3 ¹ / ₁₆	2 ¹ / ₁₆	3 ¹ / ₁₆	3 ¹ / ₁₆	2 ¹ / ₁₆	60.0	10 C 105 J	A-1	J	4 ¹ / ₂	2 ¹ / ₁₆	3 ¹ / ₁₆	4 ¹ / ₂	3 ¹ / ₂	75.0
8 C 105 F	10.50	10.90	A-1	F	3 ¹ / ₁₆	2 ¹ / ₁₆	3 ¹ / ₁₆	3 ¹ / ₁₆	2 ¹ / ₁₆	67.0	10 C 110 J	A-1	J	4 ¹ / ₂	2 ¹ / ₁₆	3 ¹ / ₁₆	4 ¹ / ₂	3 ¹ / ₂	90.0
8 C 110 F	11.00	11.40	A-1	F	3 ¹ / ₁₆	2 ¹ / ₁₆	3 ¹ / ₁₆	3 ¹ / ₁₆	2 ¹ / ₁₆	74.0	10 C 120 J	A-1	J	4 ¹ / ₂	2 ¹ / ₁₆	3 ¹ / ₁₆	4 ¹ / ₂	3 ¹ / ₂	106.0
8 C 120 F	12.00	12.40	A-1	F	3 ¹ / ₁₆	2 ¹ / ₁₆	3 ¹ / ₁₆	3 ¹ / ₁₆	2 ¹ / ₁₆	87.0	10 C 130 J	A-2	J	4 ¹ / ₂	2 ¹ / ₁₆	3 ¹ / ₁₆	4 ¹ / ₂	3 ¹ / ₂	110.0
8 C 130 F	13.00	13.40	A-3	F	3 ¹ / ₁₆	2 ¹ / ₁₆	3 ¹ / ₁₆	3 ¹ / ₁₆	2 ¹ / ₁₆	94.0	10 C 140 J	A-2	J	4 ¹ / ₂	2 ¹ / ₁₆	3 ¹ / ₁₆	4 ¹ / ₂	3 ¹ / ₂	124.0
8 C 140 F	14.00	14.40	A-3	F	3 ¹ / ₁₆	2 ¹ / ₁₆	3 ¹ / ₁₆	3 ¹ / ₁₆	2 ¹ / ₁₆	99.0	10 C 150 J	A-2	J	4 ¹ / ₂	2 ¹ / ₁₆	3 ¹ / ₁₆	4 ¹ / ₂	3 ¹ / ₂	138.0
8 C 150 F	15.00	15.40	A-2	F	3 ¹ / ₁₆	2 ¹ / ₁₆	3 ¹ / ₁₆	3 ¹ / ₁₆	2 ¹ / ₁₆	111.0	10 C 160 J	A-3	J	4 ¹ / ₂	2 ¹ / ₁₆	3 ¹ / ₁₆	4 ¹ / ₂	3 ¹ / ₂	139.0
8 C 160 F	16.00	16.40	A-3	F	3 ¹ / ₁₆	2 ¹ / ₁₆	3 ¹ / ₁₆	3 ¹ / ₁₆	2 ¹ / ₁₆	112.0	10 C 180 J	A-3	J	4 ¹ / ₂	2 ¹ / ₁₆	3 ¹ / ₁₆	4 ¹ / ₂	3 ¹ / ₂	168.0
8 C 180 F	18.00	18.40	A-3	F	3 ¹ / ₁₆	2 ¹ / ₁₆	3 ¹ / ₁₆	3 ¹ / ₁₆	2 ¹ / ₁₆	116.0	10 C 200 J	A-3	J	4 ¹ / ₂	2 ¹ / ₁₆	3 ¹ / ₁₆	4 ¹ / ₂	3 ¹ / ₂	182.0
8 C 200 J	20.00	20.40	A-3	J	4 ¹ / ₂	3 ¹ / ₁₆	1 ¹ / ₁₆	4 ¹ / ₂	3 ¹ / ₂	146.0	10 C 240 M	A-3	M	5 ¹ / ₂	1 ¹ / ₁₆	1 ¹ / ₁₆	6 ¹ / ₁₆	3 ¹ / ₂	272.0
8 C 240 J	24.00	24.40	A-3	J	4 ¹ / ₂	3 ¹ / ₁₆	1 ¹ / ₁₆	4 ¹ / ₂	3 ¹ / ₂	195.0	10 C 300 M	A-3	M	5 ¹ / ₂	1 ¹ / ₁₆	1 ¹ / ₁₆	6 ¹ / ₁₆	3 ¹ / ₂	355.0
8 C 270 J	27.00	27.40	A-3	J	4 ¹ / ₂	3 ¹ / ₁₆	1 ¹ / ₁₆	4 ¹ / ₂	3 ¹ / ₂	216.0	10 C 360 M	A-3	M	5 ¹ / ₂	1 ¹ / ₁₆	1 ¹ / ₁₆	6 ¹ / ₁₆	3 ¹ / ₂	455.0
8 C 300 J	30.00	30.40	A-3	J	4 ¹ / ₂	3 ¹ / ₁₆	1 ¹ / ₁₆	4 ¹ / ₂	3 ¹ / ₂	268.0	10 C 440 M	A-3	M	5 ¹ / ₂	1 ¹ / ₁₆	1 ¹ / ₁₆	6 ¹ / ₁₆	3 ¹ / ₂	544.0
8 C 360 M	36.00	36.40	A-3	M	5 ¹ / ₂	1 ¹ / ₁₆	1 ¹ / ₁₆	6 ¹ / ₁₆	1 ¹ / ₁₆	364.0	10 C 500 M	A-3	M	5 ¹ / ₂	1 ¹ / ₁₆	1 ¹ / ₁₆	6 ¹ / ₁₆	3 ¹ / ₂	622.0
8 C 440 M	44.00	44.40	A-3	M	5 ¹ / ₂	1 ¹ / ₁₆	1 ¹ / ₁₆	6 ¹ / ₁₆	1 ¹ / ₁₆	413.0									
8 C 500 M	50.00	50.40	A-3	M	5 ¹ / ₂	1 ¹ / ₁₆	1 ¹ / ₁₆	6 ¹ / ₁₆	1 ¹ / ₁₆	474.0									

QD Sheaves — C

Nomenclature Example: **12-C-90-J**

12 Groove F = 12 ³ / ₁₆										
Part Number	PD	OD	Type	Bush	Bush Max. Bore	E	K	L Thru Bore	M	Wt. Less Bush
	C Belt									
12 C 90 J	9.00	9.40	A-1	J	4 ¹ / ₂	2 ¹ / ₁₆	4 ¹ / ₁₆	4 ¹ / ₂	5	63.0
12 C 95 J	9.50	9.90	A-1	J	4 ¹ / ₂	2 ¹ / ₁₆	4 ¹ / ₁₆	4 ¹ / ₂	5	75.0
12 C 100 J	10.00	10.40	A-1	J	4 ¹ / ₂	2 ¹ / ₁₆	4 ¹ / ₁₆	4 ¹ / ₂	5	84.0
12 C 105 J	10.50	10.90	A-1	J	4 ¹ / ₂	2 ¹ / ₁₆	4 ¹ / ₁₆	4 ¹ / ₂	5	86.0
12 C 110 J	11.00	11.40	A-1	J	4 ¹ / ₂	2 ¹ / ₁₆	4 ¹ / ₁₆	4 ¹ / ₂	5	97.0
12 C 120 J	12.00	12.40	A-1	J	4 ¹ / ₂	2 ¹ / ₁₆	4 ¹ / ₁₆	4 ¹ / ₂	5	119.0
12 C 130 J	13.00	13.40	A-2	J	4 ¹ / ₂	2 ¹ / ₁₆	4 ¹ / ₁₆	4 ¹ / ₂	5	125.0
12 C 140 J	14.00	14.40	A-2	J	4 ¹ / ₂	2 ¹ / ₁₆	4 ¹ / ₁₆	4 ¹ / ₂	5	139.0
12 C 150 J	15.00	15.40	A-2	J	4 ¹ / ₂	2 ¹ / ₁₆	4 ¹ / ₁₆	4 ¹ / ₂	5	156.0
12 C 160 J	16.00	16.40	A-3	J	4 ¹ / ₂	2 ¹ / ₁₆	4 ¹ / ₁₆	4 ¹ / ₂	5	175.0
12 C 180 J	18.00	18.40	A-3	J	4 ¹ / ₂	2 ¹ / ₁₆	4 ¹ / ₁₆	4 ¹ / ₂	5	185.0
12 C 200 M	20.00	20.40	A-3	M	5 ¹ / ₂	1 ¹ / ₁₆	1 ¹ / ₁₆	6 ¹ / ₁₆	5 ¹ / ₂	228.0
12 C 240 M	24.00	24.40	A-3	M	5 ¹ / ₂	1 ¹ / ₁₆	1 ¹ / ₁₆	6 ¹ / ₁₆	5 ¹ / ₂	287.0
12 C 300 M	30.00	30.40	A-3	M	5 ¹ / ₂	1 ¹ / ₁₆	1 ¹ / ₁₆	6 ¹ / ₁₆	5 ¹ / ₂	350.0
12 C 360 M	36.00	36.40	A-3	M	5 ¹ / ₂	1 ¹ / ₁₆	1 ¹ / ₁₆	6 ¹ / ₁₆	5 ¹ / ₂	430.0
12 C 440 M	44.00	44.40	A-3	M	5 ¹ / ₂	1 ¹ / ₁₆	1 ¹ / ₁₆	6 ¹ / ₁₆	5 ¹ / ₂	565.0
12 C 500 M	50.00	50.40	A-3	M	5 ¹ / ₂	1 ¹ / ₁₆	1 ¹ / ₁₆	6 ¹ / ₁₆	5 ¹ / ₂	595.0

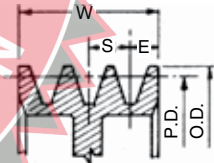

Combination Groove Dimensions

Belt Section	E	S	OD
"C"	1 ¹ / ₁₆	1	P.D. + .40

W = S(N-1) + 2E
N = No. of Grooves

Dimensions in inches, weight in pounds. Weights do not include bushings. See page B-3 and B-4 for additional bushing dimensions.

PLEASE NOTE: Dashes are REQUIRED in place of spaces when ordering or searching on PTplace.com.

QD Sheaves — D

Nomenclature Example: 3-D-120-F

3 Groove											4 Groove								
F = 4%											F = 6 1/6%								
Part Number	PD D Belt	OD	Type	Bush	Bush Max. Bore	E	K	L Thru Bore	M	Wt. Less Bush	Part Number	Type	Bush	Bush Max. Bore	E	K	L Thru Bore	M	Wt. Less Bush
3 D 120 F	12.0	12.6	A-2	F	3 1/8	1/2	1 1/2	3%	1/2	58.0	4 D 120 F	A-2	F	3 1/8	1 1/8	2 3/8	3%	1 1/8	68.0
3 D 130 F	13.0	13.6	A-2	F	3 3/8	1/2	1 1/2	3%	1/2	63.0	4 D 130 F	A-2	F	3 3/8	1 1/8	2 3/8	3%	1 1/8	78.0
3 D 135 F	13.5	14.1	A-2	F	3 3/8	1/2	1 1/2	3%	1/2	68.0	4 D 135 F	A-2	F	3 3/8	1 1/8	2 3/8	3%	1 1/8	82.0
3 D 140 F	14.0	14.6	A-2	F	3 3/8	1/2	1 1/2	3%	1/2	71.0	4 D 140 F	A-2	F	3 3/8	1 1/8	2 3/8	3%	1 1/8	91.0
3 D 145 F	14.5	15.1	A-2	F	3 3/8	1/2	1 1/2	3%	1/2	82.0	4 D 145 F	A-2	F	3 3/8	1 1/8	2 3/8	3%	1 1/8	93.0
3 D 150 F	15.0	15.6	A-2	F	3 3/8	1/2	1 1/2	3%	1/2	86.0	4 D 150 F	A-2	F	3 3/8	1 1/8	2 3/8	3%	1 1/8	99.0
3 D 155 F	15.5	16.1	A-2	F	3 3/8	1/2	1 1/2	3%	1/2	93.0	4 D 155 F	A-2	F	3 3/8	1 1/8	2 3/8	3%	1 1/8	111.0
3 D 160 F	16.0	16.6	A-2	F	3 3/8	1/2	1 1/2	3%	1/2	95.0	4 D 160 F	A-2	F	3 3/8	1 1/8	2 3/8	3%	1 1/8	122.0
3 D 180 J	18.0	18.6	A-3	J	4 1/2	0	1 3/8	4 1/2	1/2	105.0	4 D 170 J	A-2	J	4 1/2	1 3/8	2 3/8	4 1/2	3/8	136.0
3 D 200 J	20.0	20.6	A-2	J	4 1/2	0	1 3/8	4 1/2	1/2	148.0	4 D 180 J	A-3	J	4 1/2	1 3/8	2 3/8	4 1/2	3/8	141.0
3 D 220 J	22.0	22.6	A-3	J	4 1/2	0	1 3/8	4 1/2	1/2	164.0	4 D 200 J	A-2	J	4 1/2	3/8	1 3/8	4 1/2	1 3/8	167.0
3 D 270 J	27.0	27.6	A-3	J	4 1/2	0	1 3/8	4 1/2	1/2	180.0	4 D 220 J	A-3	J	4 1/2	3/8	1 3/8	4 1/2	1 3/8	183.0
3 D 330 J	33.0	33.6	A-3	J	4 1/2	0	1 3/8	4 1/2	1/2	195.0	4 D 270 J	A-3	J	4 1/2	3/8	1 3/8	4 1/2	1 3/8	222.0
3 D 400 J	40.0	40.6	A-3	J	4 1/2	0	1 3/8	4 1/2	1/2	260.0	4 D 330 M	B-3	M	5 1/2	1/2	1 3/8	6%	1 3/8	315.0
											4 D 400 M	B-3	M	5 1/2	1/2	1 3/8	6%	1 3/8	337.0

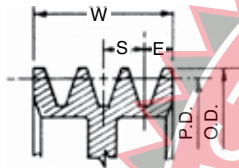

Groove Dimensions

Belt Section	E	S	O.D.
"D"	7/8	1 1/8	P.D. + .60

W = S(N-1) + 2E
N = No. of Grooves

QD Sheaves — D

Nomenclature Example: 5-D-120-F

5 Groove										
F = 7 1/2%										
Part Number	PD D Belt	OD	Type	Bush	Bush Max. Bore	E	K	L Thru Bore	M	Wt. Less Bush
5 D 120 F	12.0	12.6	A-2	F	3 1/8	2 1/8	3 3/8	3%	1 1/8	87.0
5 D 130 F	13.0	13.6	A-2	F	3 3/8	2 1/8	3 3/8	3%	1 1/8	88.0
5 D 135 F	13.5	14.1	A-2	F	3 3/8	2 1/8	3 3/8	3%	1 1/8	92.0
5 D 140 F	14.0	14.6	A-2	F	3 3/8	2 1/8	3 3/8	3%	1 1/8	96.0
5 D 145 F	14.5	15.1	A-2	F	3 3/8	2 1/8	3 3/8	3%	1 1/8	111.0
5 D 150 F	15.0	15.6	A-2	F	3 3/8	2 1/8	3 3/8	3%	1 1/8	115.0
5 D 155 F	15.5	16.1	A-2	F	3 3/8	2 1/8	3 3/8	3%	1 1/8	121.0
5 D 160 F	16.0	16.6	A-2	F	3 3/8	2 1/8	3 3/8	3%	1 1/8	128.0
5 D 170 J	17.0	17.6	A-2	J	4 1/2	3/8	1 3/8	4 1/2	2 3/8	135.0
5 D 180 J	18.0	18.6	A-3	J	4 1/2	3/8	1 3/8	4 1/2	2 3/8	148.0
5 D 200 J	20.0	20.6	A-3	J	4 1/2	3/8	1 3/8	4 1/2	2 3/8	184.0
5 D 220 J	22.0	22.6	A-3	J	4 1/2	3/8	1 3/8	4 1/2	2 3/8	202.0
5 D 270 M	27.0	27.6	A-3	M	5 1/2	1/2	1 3/8	6%	1/4	250.0
5 D 330 M	33.0	33.6	A-3	M	5 1/2	1/2	1 3/8	6%	1/4	280.0
5 D 400 M	40.0	40.6	A-3	M	5 1/2	1/2	1 3/8	6%	1/4	380.0

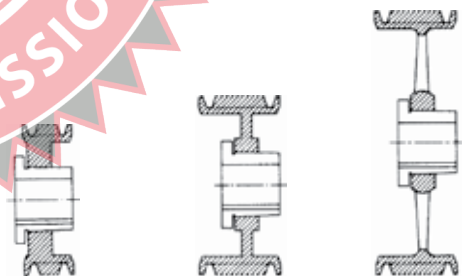

1 = SOLID

2 = WEB

3 = ARM/SPOKE

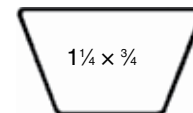

D

Dimensions in inches, weight in pounds. Weights do not include bushings. See page B-3 an B-4 for additional bushing dimensions.

PLEASE NOTE: Dashes are REQUIRED in place of spaces when ordering or searching on PTplace.com.

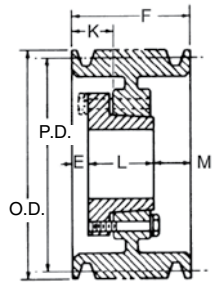

TYPE A

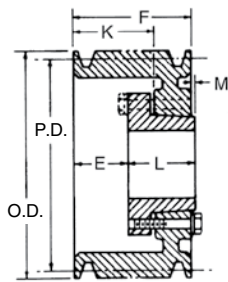

TYPE B

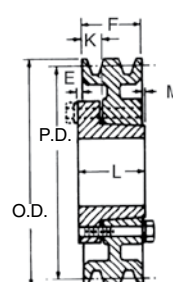

TYPE C

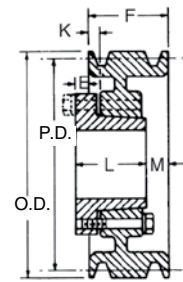

TYPE D

QD Sheaves — D

Nomenclature Example: **6-D-120-J**

6 Groove F = 8 ¹⁵ / ₁₆											8 Groove F = 11 ¹³ / ₁₆								
Part Number	PD D Belt	OD	Type	Bush	Bush Max. Bore	E	K	L Thru Bore	M	Wt. Less Bush	Part Number	Type	Bush	Bush Max. Bore	E	K	L Thru Bore	M	Wt. Less Bush
6 D 120 J	12.00	12.60	A-1	J	4 ¹ / ₂	2 ¹ / ₂	3 ³ / ₁₆	4 ¹ / ₂	2 ¹ / ₂	104.0	8 D 120 J	A-1	J	4 ¹ / ₂	2 ¹ / ₂	3 ³ / ₁₆	4 ¹ / ₂	4 ¹ / ₂	126.0
6 D 130 J	13.00	13.60	A-1	J	4 ¹ / ₂	2 ¹ / ₂	3 ³ / ₁₆	4 ¹ / ₂	2 ¹ / ₂	122.0	8 D 130 J	A-1	J	4 ¹ / ₂	2 ¹ / ₂	3 ³ / ₁₆	4 ¹ / ₂	4 ¹ / ₂	147.0
6 D 135 J	13.50	14.10	A-1	J	4 ¹ / ₂	2 ¹ / ₂	3 ³ / ₁₆	4 ¹ / ₂	2 ¹ / ₂	125.0	8 D 135 J	A-1	J	4 ¹ / ₂	2 ¹ / ₂	3 ³ / ₁₆	4 ¹ / ₂	4 ¹ / ₂	150.0
6 D 140 J	14.00	14.60	A-2	J	4 ¹ / ₂	2 ¹ / ₂	3 ³ / ₁₆	4 ¹ / ₂	2 ¹ / ₂	128.0	8 D 140 J	A-1	J	4 ¹ / ₂	2 ¹ / ₂	3 ³ / ₁₆	4 ¹ / ₂	4 ¹ / ₂	155.0
6 D 145 J	14.50	15.10	A-2	J	4 ¹ / ₂	2 ¹ / ₂	3 ³ / ₁₆	4 ¹ / ₂	2 ¹ / ₂	130.0	8 D 145 J	A-1	J	4 ¹ / ₂	2 ¹ / ₂	3 ³ / ₁₆	4 ¹ / ₂	4 ¹ / ₂	160.0
6 D 150 J	15.00	15.60	A-2	J	4 ¹ / ₂	2 ¹ / ₂	3 ³ / ₁₆	4 ¹ / ₂	2 ¹ / ₂	136.0	8 D 150 J	A-2	J	4 ¹ / ₂	2 ¹ / ₂	3 ³ / ₁₆	4 ¹ / ₂	4 ¹ / ₂	176.0
6 D 155 J	15.50	16.10	A-2	J	4 ¹ / ₂	2 ¹ / ₂	3 ³ / ₁₆	4 ¹ / ₂	2 ¹ / ₂	139.0	8 D 155 J	A-2	J	4 ¹ / ₂	2 ¹ / ₂	3 ³ / ₁₆	4 ¹ / ₂	4 ¹ / ₂	180.0
6 D 160 J	16.00	16.60	A-2	J	4 ¹ / ₂	2 ¹ / ₂	3 ³ / ₁₆	4 ¹ / ₂	2 ¹ / ₂	141.0	8 D 160 J	A-2	J	4 ¹ / ₂	2 ¹ / ₂	3 ³ / ₁₆	4 ¹ / ₂	4 ¹ / ₂	200.0
6 D 170 J	17.00	17.60	A-2	J	4 ¹ / ₂	2 ¹ / ₂	3 ³ / ₁₆	4 ¹ / ₂	2 ¹ / ₂	154.0	8 D 170 M	A-1	M	5 ¹ / ₂	2 ¹ / ₂	3 ³ / ₁₆	6 ¹ / ₂	2 ¹ / ₂	225.0
6 D 180 J	18.00	18.60	A-2	J	4 ¹ / ₂	2 ¹ / ₂	3 ³ / ₁₆	4 ¹ / ₂	2 ¹ / ₂	172.0	8 D 180 M	A-2	M	5 ¹ / ₂	2 ¹ / ₂	3 ³ / ₁₆	6 ¹ / ₂	2 ¹ / ₂	250.0
6 D 200 J	20.00	20.60	A-2	J	4 ¹ / ₂	2 ¹ / ₂	3 ³ / ₁₆	4 ¹ / ₂	2 ¹ / ₂	183.0	8 D 200 M	A-2	M	5 ¹ / ₂	2 ¹ / ₂	3 ³ / ₁₆	6 ¹ / ₂	2 ¹ / ₂	270.0
6 D 220 M	22.00	22.60	A-2	M	5 ¹ / ₂	1 ¹ / ₂	1 ¹ / ₁₆	6 ¹ / ₂	1 ¹ / ₁₆	272.0	8 D 220 M	A-2	M	5 ¹ / ₂	1 ¹ / ₂	1 ¹ / ₁₆	6 ¹ / ₂	4 ¹ / ₂	316.0
6 D 270 M	27.00	27.60	A-3	M	5 ¹ / ₂	1 ¹ / ₂	1 ¹ / ₁₆	6 ¹ / ₂	1 ¹ / ₁₆	280.0	8 D 270 N	A-3	M	5 ¹ / ₂	1 ¹ / ₂	1 ¹ / ₁₆	6 ¹ / ₂	4 ¹ / ₂	440.0
6 D 330 M	33.00	33.60	A-3	M	5 ¹ / ₂	1 ¹ / ₂	1 ¹ / ₁₆	6 ¹ / ₂	1 ¹ / ₁₆	356.0	8 D 330 N	A-3	M	5 ¹ / ₂	1 ¹ / ₂	1 ¹ / ₁₆	6 ¹ / ₂	4 ¹ / ₂	458.0
6 D 400 M	40.00	40.60	A-3	M	5 ¹ / ₂	1 ¹ / ₂	1 ¹ / ₁₆	6 ¹ / ₂	1 ¹ / ₁₆	415.0	8 D 400 N	A-3	N	5 ¹ / ₂	1 ¹ / ₂	2 ¹ / ₂	8 ¹ / ₂	3 ³ / ₁₆	638.0
6 D 440 M	44.00	44.60	A-3	M	5 ¹ / ₂	1 ¹ / ₂	1 ¹ / ₁₆	6 ¹ / ₂	1 ¹ / ₁₆	536.0	8 D 440 N	A-3	N	6 ¹ / ₂	1 ¹ / ₂	2 ¹ / ₂	8 ¹ / ₂	3 ³ / ₁₆	616.0
6 D 480 M	48.00	48.60	A-3	M	5 ¹ / ₂	1 ¹ / ₂	1 ¹ / ₁₆	6 ¹ / ₂	1 ¹ / ₁₆	572.0	8 D 480 N	A-3	N	6 ¹ / ₂	1 ¹ / ₂	2 ¹ / ₂	8 ¹ / ₂	3 ³ / ₁₆	755.0
6 D 580 N	58.00	58.60	A-3	N	6 ¹ / ₂	1 ¹ / ₂	2 ¹ / ₂	8 ¹ / ₂	3 ³ / ₁₆	1006.0	8 D 580 N	A-3	N	6 ¹ / ₂	1 ¹ / ₂	2 ¹ / ₂	8 ¹ / ₂	3 ³ / ₁₆	1112.0

10 Groove F = 14 ¹¹ / ₁₆											12 Groove F = 17 ⁷ / ₁₆									
Part Number	PD D Belt	OD	Type	Bush	Bush Max. Bore	E	K	L Thru Bore	M	Wt. Less Bush	Part Number	Type	Bush	Bush Max. Bore	E	K	L Thru Bore	M	Wt. Less Bush	
10 D 120 M	12.00	12.60	A-1	M	5 ¹ / ₂	2 ¹ / ₂	3 ³ / ₁₆	6 ¹ / ₂	5 ¹ / ₂	158.0	12 D 120 M	A-1	M	5 ¹ / ₂	3 ¹ / ₂	4 ¹ / ₁₆	6 ¹ / ₂	7 ¹ / ₂	158.0	
10 D 125 M	12.50	13.10	A-1	M	5 ¹ / ₂	2 ¹ / ₂	3 ³ / ₁₆	6 ¹ / ₂	5 ¹ / ₂	178.0										
10 D 130 M	13.00	13.60	A-1	M	5 ¹ / ₂	2 ¹ / ₂	3 ³ / ₁₆	6 ¹ / ₂	5 ¹ / ₂	196.0	12 D 130 M	A-1	M	5 ¹ / ₂	3 ¹ / ₂	4 ¹ / ₁₆	6 ¹ / ₂	7 ¹ / ₂	219.0	
10 D 135 M	13.50	14.10	A-1	M	5 ¹ / ₂	2 ¹ / ₂	3 ³ / ₁₆	6 ¹ / ₂	5 ¹ / ₂	207.0	12 D 135 M	A-1	M	5 ¹ / ₂	3 ¹ / ₂	4 ¹ / ₁₆	6 ¹ / ₂	7 ¹ / ₂	242.0	
10 D 140 M	14.00	14.60	A-1	M	5 ¹ / ₂	2 ¹ / ₂	3 ³ / ₁₆	6 ¹ / ₂	5 ¹ / ₂	225.0	12 D 140 M	A-1	M	5 ¹ / ₂	3 ¹ / ₂	4 ¹ / ₁₆	6 ¹ / ₂	7 ¹ / ₂	246.0	
10 D 145 M	14.50	15.10	A-1	M	5 ¹ / ₂	2 ¹ / ₂	3 ³ / ₁₆	6 ¹ / ₂	5 ¹ / ₂	238.0	12 D 145 M	A-1	M	5 ¹ / ₂	3 ¹ / ₂	4 ¹ / ₁₆	6 ¹ / ₂	7 ¹ / ₂	266.0	
10 D 150 M	15.00	15.60	A-1	M	5 ¹ / ₂	2 ¹ / ₂	3 ³ / ₁₆	6 ¹ / ₂	5 ¹ / ₂	260.0	12 D 150 M	A-1	M	5 ¹ / ₂	3 ¹ / ₂	4 ¹ / ₁₆	6 ¹ / ₂	7 ¹ / ₂	287.0	
10 D 155 M	15.50	16.10	A-1	M	5 ¹ / ₂	2 ¹ / ₂	3 ³ / ₁₆	6 ¹ / ₂	5 ¹ / ₂	279.0	12 D 155 M	A-1	M	5 ¹ / ₂	3 ¹ / ₂	4 ¹ / ₁₆	6 ¹ / ₂	7 ¹ / ₂	308.0	
10 D 160 M	16.00	16.60	A-1	M	5 ¹ / ₂	2 ¹ / ₂	3 ³ / ₁₆	6 ¹ / ₂	5 ¹ / ₂	292.0	12 D 160 M	A-1	M	5 ¹ / ₂	3 ¹ / ₂	4 ¹ / ₁₆	6 ¹ / ₂	7 ¹ / ₂	325.0	
10 D 170 M	17.00	17.60	A-1	M	5 ¹ / ₂	2 ¹ / ₂	3 ³ / ₁₆	6 ¹ / ₂	5 ¹ / ₂	330.0	12 D 170 M	A-1	M	5 ¹ / ₂	3 ¹ / ₂	4 ¹ / ₁₆	6 ¹ / ₂	7 ¹ / ₂	330.0	
10 D 180 M	18.00	18.60	A-1	M	5 ¹ / ₂	2 ¹ / ₂	3 ³ / ₁₆	6 ¹ / ₂	5 ¹ / ₂	340.0	12 D 180 M	A-1	M	5 ¹ / ₂	3 ¹ / ₂	4 ¹ / ₁₆	6 ¹ / ₂	7 ¹ / ₂	340.0	
10 D 200 M	20.00	20.60	A-2	M	5 ¹ / ₂	2 ¹ / ₂	3 ³ / ₁₆	6 ¹ / ₂	5 ¹ / ₂	355.0	12 D 200 M	A-2	M	5 ¹ / ₂	3 ¹ / ₂	4 ¹ / ₁₆	6 ¹ / ₂	7 ¹ / ₂	355.0	
10 D 220 M	22.00	22.60	A-3	M	5 ¹ / ₂	1 ¹ / ₂	2 ¹ / ₁₆	6 ¹ / ₂	6 ¹ / ₂	348.0	12 D 220 M	A-2	M	5 ¹ / ₂	2 ¹ / ₂	3 ³ / ₁₆	6 ¹ / ₂	8 ¹ / ₂	392.0	
10 D 270 M	27.00	27.60	A-3	M	5 ¹ / ₂	1 ¹ / ₂	2 ¹ / ₁₆	6 ¹ / ₂	6 ¹ / ₂	434.0	12 D 270 M	A-3	N	6 ¹ / ₂	2 ¹ / ₂	4 ¹ / ₂	6 ¹ / ₂	6 ¹ / ₂	505.0	
10 D 330 N	33.00	33.60	A-3	N	6 ¹ / ₂	1 ¹ / ₂	3 ³ / ₁₆	8 ¹ / ₂	5 ¹ / ₂	502.0	12 D 330 M	A-3	N	6 ¹ / ₂	2 ¹ / ₂	4 ¹ / ₂	6 ¹ / ₂	6 ¹ / ₂	619.0	
10 D 400 N	40.00	40.60	A-3	N	6 ¹ / ₂	1 ¹ / ₂	3 ³ / ₁₆	8 ¹ / ₂	5 ¹ / ₂	727.0	12 D 400 P	A-3	P	6 ¹ / ₂	3 ³ / ₁₆	2 ¹ / ₂	8 ¹ / ₂	7 ¹ / ₂	946.0	
10 D 480 P	48.00	48.60	A-3	P	6 ¹ / ₂	1 ¹ / ₂	2 ¹ / ₁₆	9 ¹ / ₂	4 ¹ / ₁₆	755.0	12 D 480 P	A-3	P	6 ¹ / ₂	3 ³ / ₁₆	2 ¹ / ₂	8 ¹ / ₂	7 ¹ / ₂	1155.0	
10 D 580 P	58.00	58.60	A-3	P	6 ¹ / ₂	1 ¹ / ₂	2 ¹ / ₁₆	9 ¹ / ₂	4 ¹ / ₁₆	1286.0	12 D 580 P	A-3	P	6 ¹ / ₂	3 ³ / ₁₆	2 ¹ / ₂	8 ¹ / ₂	7 ¹ / ₂	1576.0	

★ E and M dimensions are nominal and will vary depending on shaft tolerances. See page B-3 and B-4 for additional bushing dimensions.

PLEASE NOTE: Dashes are REQUIRED in place of spaces when ordering or searching on PTplace.com.

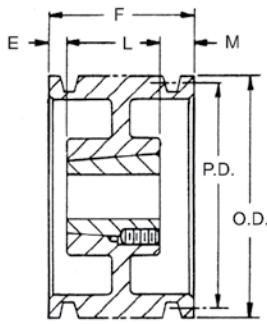

TYPE A

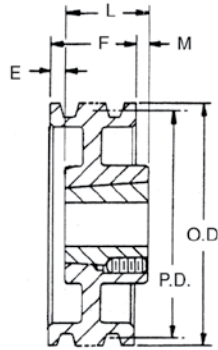

TYPE B

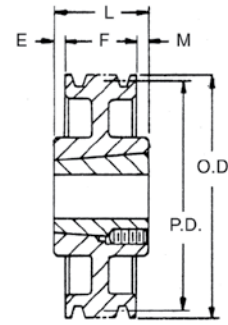

TYPE C



1 = SOLID



2 = WEB



3 = ARM/SPOKE

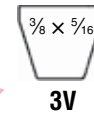

3V

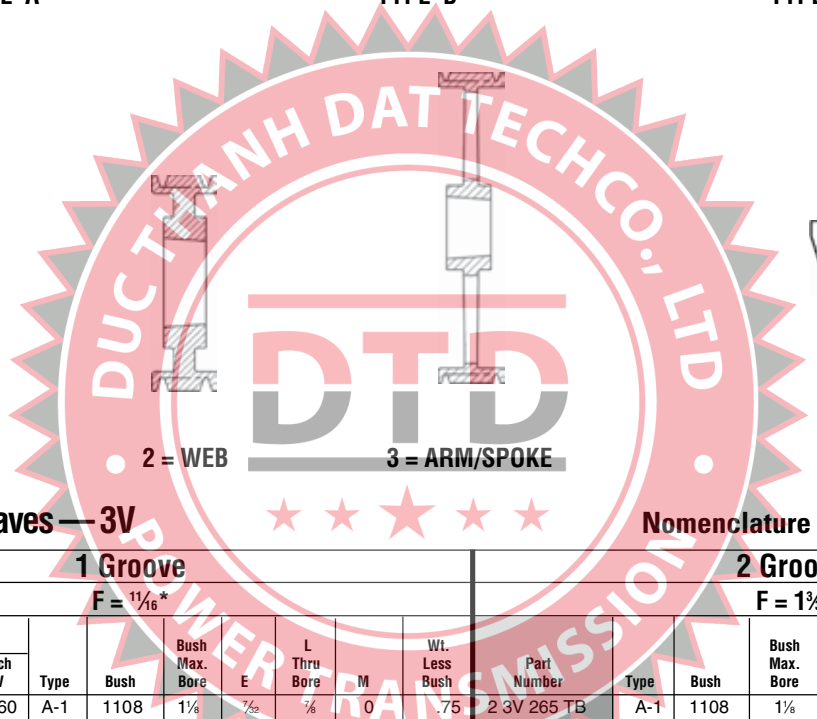

Taper Bushed Sheaves — 3V

Nomenclature Example: 1-3V-265-TB

1 Groove F = 1 1/16"*										2 Groove F = 1 3/8"							
Part Number	Diameters		Type	Bush	Bush Max. Bore	E	L Thru Bore	M	Wt. Less Bush	Part Number	Type	Bush	Bush Max. Bore	E	L Thru Bore	M	Wt. Less Bush
	OD	Pitch 3V															
1 3V 265 TB	2.65	2.60	A-1	1108	1 1/8	7/32	7/8	0	.75	2 3V 265 TB	A-1	1108	1 1/8	7/32	7/8	0	.75
1 3V 280 TB	2.80	2.75	A-1	1108	1 1/8	7/32	7/8	0	.85	2 3V 280 TB	A-1	1108	1 1/8	7/32	7/8	0	.90
1 3V 300 TB	3.00	2.95	A-1	1108	1 1/8	7/32	7/8	0	1.00	2 3V 300 TB	A-1	1210	1 1/4	1/2	1	0	1.40
1 3V 315 TB	3.15	3.10	A-1	1108	1 1/8	7/32	7/8	0	1.25	2 3V 315 TB	A-1	1210	1 1/4	1/2	1	0	1.60
1 3V 335 TB	3.35	3.30	A-1	1610	1 1/8	0	1	0	1.50	2 3V 335 TB	A-1	1610	1 1/8	1/2	1	0	1.70
1 3V 365 TB	3.65	3.60	A-1	1610	1 1/8	0	1	0	2.00	2 3V 365 TB	A-1	1610	1 1/8	1/2	1 1/2	0	2.00
1 3V 412 TB	4.12	4.07	B-1	1610	1 1/8	0	1	1 1/32	2.25	2 3V 412 TB	A-1	1610	1 1/8	0	1	0	2.10
1 3V 450 TB	4.50	4.45	B-1	1610	1 1/8	0	1	1 1/32	3.00	2 3V 450 TB	A-1	1610	1 1/8	0	1	0	2.70
1 3V 475 TB	4.75	4.70	B-1	1610	1 1/8	0	1	1 1/32	3.25	2 3V 475 TB	A-1	1610	1 1/8	0	1	0	3.00
1 3V 500 TB	5.00	4.95	B-1	1610	1 1/8	0	1	1 1/32	3.50	2 3V 500 TB	A-1	1610	1 1/8	0	1	0	4.00
1 3V 530 TB	5.30	5.25	B-1	1610	1 1/8	0	1	1 1/32	3.75	2 3V 530 TB	A-1	1610	1 1/8	0	1	0	5.00
1 3V 560 TB	5.60	5.55	B-1	1610	1 1/8	0	1	1 1/32	4.00	2 3V 560 TB	A-1	1610	1 1/8	0	1	0	6.00
1 3V 600 TB	6.00	5.95	B-1	1610	1 1/8	0	1	1 1/32	5.00	2 3V 600 TB	A-1	1610	1 1/8	0	1	0	7.00
1 3V 650 TB	6.50	6.45	B-1	1610	1 1/8	0	1	1 1/32	6.00	2 3V 650 TB	A-1	1610	1 1/8	0	1	0	8.00
1 3V 690 TB	6.90	6.85	B-1	1610	1 1/8	0	1	1 1/32	7.00	2 3V 690 TB	A-1	1610	1 1/8	0	1	0	9.00
1 3V 800 TB	8.00	7.95	B-2	2517	2 1/2	0	1 1/4	1 1/8	9.00	2 3V 800 TB	B-2	2517	2 1/2	0	1 1/4	2 1/32	10.0
1 3V 1060 TB	10.60	10.55	B-2	2517	2 1/2	0	1 1/4	1 1/8	13.00	2 3V 1060 TB	B-2	2517	2 1/2	0	1 1/4	2 1/32	14.0
1 3V 1400 TB*	14.00	13.95	B-3	2517	2 1/2	0	1 1/4	1 1/8	15.00	2 3V 1400 TB	B-3	2517	2 1/2	0	1 1/4	2 1/32	18.0
1 3V 1900 TB*	19.00	18.95	B-3	3020	3	0	2	1 1/8	27.00	2 3V 1900 TB	B-3	3020	3	0	2	2 1/32	32.0
	25.00	24.95								2 3V 2500 TB	C-3	3020	3	1/8	2	2 1/32	45.0

* F = 1 1/16" thru 1 3V 1400 TB
F = 1 3/8" thru 1 3V 1400 TB and 1 3V 1900 TB

PLEASE NOTE: Dashes are REQUIRED in place of spaces when ordering or searching on PTplace.com.

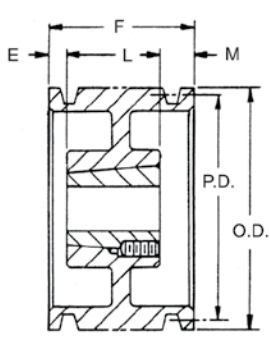

TYPE A

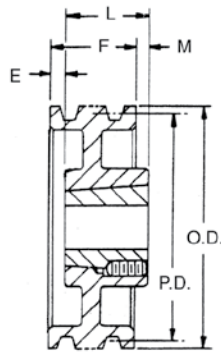

TYPE B

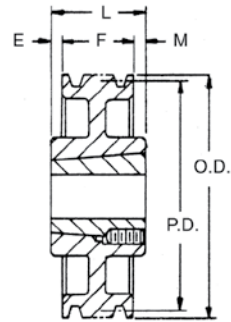

TYPE C



1 = SOLID



2 = WEB



3 = ARM/SPOKE



3V

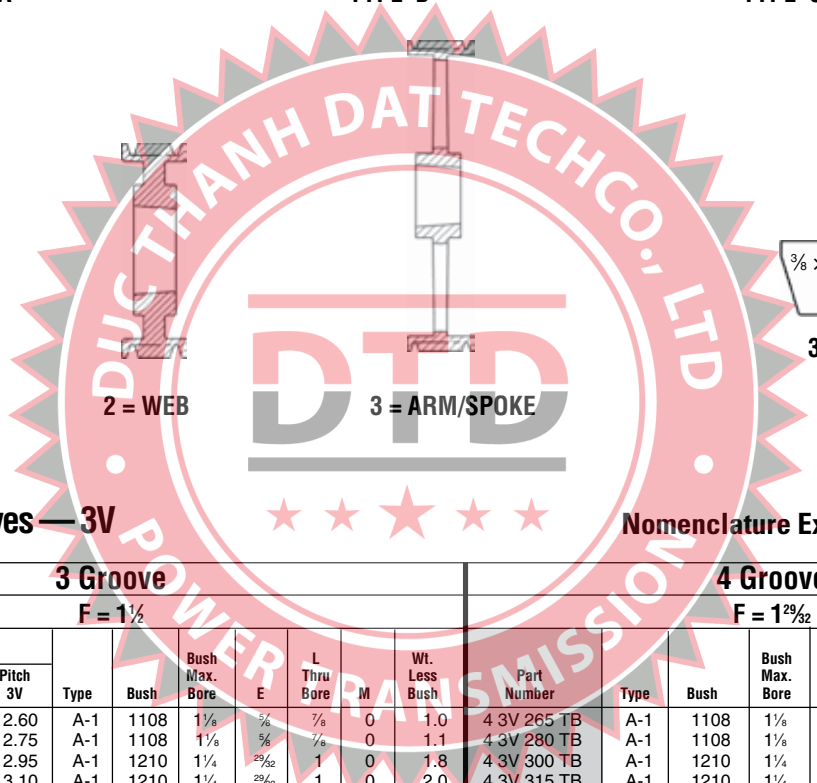

Taper Bushed Sheaves — 3V

Nomenclature Example: **3-3V-265-TB**

3 Groove F = 1 1/2										4 Groove F = 1 29/32							
Part Number	Diameter		Type	Bush	Bush Max. Bore	E	L Thru Bore	M	Wt. Less Bush	Part Number	Type	Bush	Bush Max. Bore	E	L Thru Bore	M	Wt. Less Bush
	OD	Pitch 3V															
3 3V 265 TB	2.65	2.60	A-1	1108	1 1/8	5/16	7/8	0	1.0	4 3V 265 TB	A-1	1108	1 1/8	1 1/32	7/8	0	1.2
3 3V 280 TB	2.80	2.75	A-1	1108	1 1/8	5/16	7/8	0	1.1	4 3V 280 TB	A-1	1108	1 1/8	1 1/32	7/8	0	1.3
3 3V 300 TB	3.00	2.95	A-1	1210	1 1/4	29/32	1	0	1.8	4 3V 300 TB	A-1	1210	1 1/4	1 1/16	1	0	2.1
3 3V 315 TB	3.15	3.10	A-1	1210	1 1/4	29/32	1	0	2.0	4 3V 315 TB	A-1	1210	1 1/4	1 1/16	1	0	2.2
3 3V 335 TB	3.35	3.30	A-1	1610	1 5/8	29/32	1	0	2.3	4 3V 335 TB	A-1	1610	1 5/8	1 1/16	1	0	2.4
3 3V 365 TB	3.65	3.60	A-1	1610	1 5/8	29/32	1	0	2.6	4 3V 365 TB	A-1	1610	1 5/8	29/32	1	0	2.8
3 3V 412 TB	4.12	4.07	A-1	1610	1 5/8	1/2	1	0	3.0	4 3V 412 TB	A-1	1610	1 5/8	29/32	1	0	3.0
3 3V 450 TB	4.50	4.45	A-1	1610	1 5/8	1/2	1	0	3.2	4 3V 450 TB	A-1	1610	1 5/8	29/32	1	0	4.0
3 3V 475 TB	4.75	4.70	A-1	1610	1 5/8	1/2	1	0	4.0	4 3V 475 TB	A-1	1610	1 5/8	29/32	1	0	5.0
3 3V 500 TB	5.00	4.95	A-1	1610	1 5/8	1/2	1	0	4.5	4 3V 500 TB	A-1	1610	1 5/8	29/32	1	0	5.5
3 3V 530 TB	5.30	5.25	A-1	1610	1 5/8	1/2	1	0	5.0	4 3V 530 TB	A-1	1610	1 5/8	29/32	1	0	6.0
3 3V 560 TB	5.60	5.55	A-1	1610	1 5/8	1/2	1	0	6.0	4 3V 560 TB	A-1	1610	1 5/8	29/32	1	0	7.0
3 3V 600 TB	6.00	5.95	B-1	2517	2 1/2	5/32	1 1/4	1 3/32	7.0	4 3V 600 TB	A-1	2517	2 1/2	5/32	1 1/4	0	8.0
3 3V 650 TB	6.50	6.45	B-1	2517	2 1/2	5/32	1 1/4	1 3/32	9.0	4 3V 650 TB	A-1	2517	2 1/2	5/32	1 1/4	0	10.0
3 3V 690 TB	6.90	6.85	B-1	2517	2 1/2	5/32	1 1/4	1 3/32	10.0	4 3V 690 TB	A-1	2517	2 1/2	5/32	1 1/4	0	12.0
3 3V 800 TB	8.00	7.95	B-1	2517	2 1/2	5/32	1 1/4	1 3/32	15.0	4 3V 800 TB	A-1	2517	2 1/2	5/32	1 1/4	0	18.0
3 3V 1060 TB	10.60	10.55	B-2	2517	2 1/2	0	1 1/4	1/4	18.0	4 3V 1060 TB	A-2	2517	2 1/2	5/32	1 1/4	0	19.0
3 3V 1400 TB	14.00	13.95	B-3	2517	2 1/2	0	1 1/4	1/4	20.0	4 3V 1400 TB	A-3	2517	2 1/2	0	1 1/4	5/32	22.0
3 3V 1900 TB	19.00	18.95	B-3	3020	3	0	2	1/2	36.0	4 3V 1900 TB	C-3	3020	3	0	2	3/32	45.0
3 3V 2500 TB	25.00	24.95	B-3	3020	3	0	2	1/2	47.0	4 3V 2500 TB	C-3	3020	3	0	2	3/32	63.0
3 3V 3350 TB	33.50	33.45	B-3	3020	3	1/4	2	1/4	76.0	4 3V 3350 TB	C-3	3030	3	35/64	3	35/64	80.0

Dimensions in inches, weight in pounds. Weights do not include bushings. See page B-8 thru B-10 for additional bushing dimensions.

PLEASE NOTE: Dashes are REQUIRED in place of spaces when ordering or searching on PTplace.com.

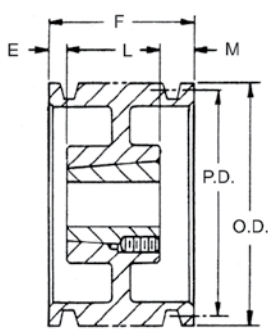

TYPE A

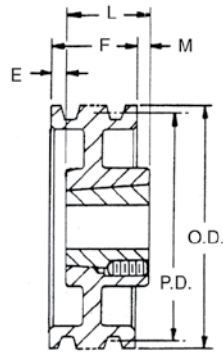

TYPE B

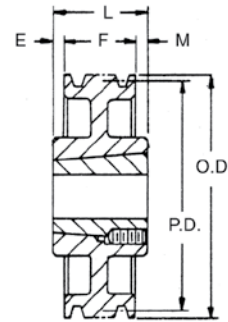

TYPE C

Taper Bushed Sheaves — 3V

Nomenclature Example: 5-3V-450-TB

5 Groove										6 Groove							
F = 2 ⁵ / ₁₆										F = 2 ²³ / ₃₂							
Part Number	Diameter		Type	Bush	Bush Max. Bore	E	L Thru Bore	M	Wt. Less Bush	Part Number	Type	Bush	Bush Max. Bore	E	L Thru Bore	M	Wt. Less Bush
	OD	Pitch 3V															
5 3V 450 TB	4.50	4.45	A-1	1615	1 ¹ / ₂	0	1 ¹ / ₂	1 ³ / ₁₆	4.0	6 3V 475 TB	A-1	2517	2 ¹ / ₂	3 ³ / ₃₂	1 ¹ / ₄	0	4.4
5 3V 475 TB	4.75	4.70	A-1	2517	2 ¹ / ₂	3 ³ / ₁₆	1 ³ / ₄	0	4.0	6 3V 500 TB	A-1	2517	2 ¹ / ₂	3 ³ / ₃₂	1 ¹ / ₄	0	5.4
5 3V 500 TB	5.00	4.95	A-1	2517	2 ¹ / ₂	3 ³ / ₁₆	1 ³ / ₄	0	4.8	6 3V 530 TB	A-1	2517	2 ¹ / ₂	3 ³ / ₃₂	1 ¹ / ₄	0	6.5
5 3V 530 TB	5.30	5.25	A-1	2517	2 ¹ / ₂	3 ³ / ₁₆	1 ³ / ₄	0	5.9	6 3V 560 TB	A-1	2517	2 ¹ / ₂	3 ³ / ₃₂	1 ¹ / ₄	0	7.7
5 3V 560 TB	5.60	5.55	A-1	2517	2 ¹ / ₂	3 ³ / ₁₆	1 ³ / ₄	0	7.0	6 3V 600 TB	A-1	2517	2 ¹ / ₂	3 ³ / ₃₂	1 ¹ / ₄	0	9.5
5 3V 600 TB	6.00	5.95	A-1	2517	2 ¹ / ₂	3 ³ / ₁₆	1 ³ / ₄	0	8.0	6 3V 650 TB	A-1	2517	2 ¹ / ₂	3 ³ / ₃₂	1 ¹ / ₄	0	12.0
5 3V 650 TB	6.50	6.45	A-1	2517	2 ¹ / ₂	3 ³ / ₁₆	1 ³ / ₄	0	11.0	6 3V 690 TB	A-1	2517	2 ¹ / ₂	3 ³ / ₃₂	1 ¹ / ₄	0	13.0
5 3V 690 TB	6.90	6.85	A-1	2517	2 ¹ / ₂	3 ³ / ₁₆	1 ³ / ₄	0	13.0	6 3V 800 TB	A-1	2517	2 ¹ / ₂	3 ³ / ₃₂	1 ¹ / ₄	0	20.0
5 3V 800 TB	8.00	7.95	A-1	2517	2 ¹ / ₂	3 ³ / ₁₆	1 ³ / ₄	0	19.0	6 3V 1060 TB	A-2	2517	2 ¹ / ₂	3 ³ / ₃₂	1 ¹ / ₄	0	21.0
5 3V 1060 TB	10.60	10.55	A-2	2517	2 ¹ / ₂	3 ³ / ₁₆	1 ³ / ₄	0	21.0	6 3V 1400 TB	A-3	2517	2 ¹ / ₂	3 ³ / ₃₂	1 ¹ / ₄	0	30.0
5 3V 1400 TB	14.00	13.95	A-3	2517	2 ¹ / ₂	0	1 ³ / ₄	3 ³ / ₁₆	30.0	6 3V 1900 TB	B-3	3020	3	0	2	2 ³ / ₃₂	51.0
5 3V 1900 TB	19.00	18.95	A-3	3030	3	0	2	5 ¹ / ₁₆	51.0	6 3V 2500 TB	B-3	3030	3	0	3	3 ³ / ₃₂	81.0
5 3V 2500 TB	25.00	24.95	B-3	3030	3	0	3	1 ¹ / ₁₆	76.0	6 3V 3350 TB	C-3	3030	3	0	3	3 ³ / ₃₂	110.0
5 3V 3350 TB	33.50	33.45	C-3	3030	3	1 ¹ / ₃₂	3	1 ¹ / ₃₂	97.0								

8 Groove										10 Groove							
F = 3 ¹⁷ / ₃₂										F = 4 ¹¹ / ₃₂							
Part Number	Diameter		Type	Bush	Bush Max. Bore	E	L Thru Bore	M	Wt. Less Bush	Part Number	Type	Bush	Bush Max. Bore	E	L Thru Bore	M	Wt. Less Bush
	OD	Pitch 3V															
8 3V 475 TB	4.75	4.70	A-1	2517	2 ¹ / ₂	1 ²⁵ / ₃₂	1 ³ / ₄	0	5.0	10 3V 475 TB	A-1	2517	2 ¹ / ₂	2 ¹⁹ / ₃₂	1 ¹ / ₄	0	6.0
8 3V 500 TB	5.00	4.95	A-1	2517	2 ¹ / ₂	1 ²⁵ / ₃₂	1 ³ / ₄	0	6.0	10 3V 500 TB	A-1	2517	2 ¹ / ₂	2 ¹⁹ / ₃₂	1 ¹ / ₄	0	7.0
8 3V 530 TB	5.30	5.25	A-1	2517	2 ¹ / ₂	1 ¹ / ₃₂	1 ³ / ₄	3 ¹ / ₄	7.8	10 3V 530 TB	A-1	2517	2 ¹ / ₂	1 ²⁷ / ₃₂	1 ¹ / ₄	3 ¹ / ₄	8.0
8 3V 560 TB	5.60	5.55	A-1	2517	2 ¹ / ₂	1 ¹ / ₄	1 ³ / ₄	1 ¹⁷ / ₃₂	9.0	10 3V 560 TB	A-1	2517	2 ¹ / ₂	1 ¹ / ₂	1 ³ / ₄	2 ³ / ₃₂	9.0
8 3V 600 TB	6.00	5.95	A-1	2517	2 ¹ / ₂	1 ¹ / ₄	1 ³ / ₄	1 ¹⁷ / ₃₂	11.0	10 3V 600 TB	A-1	2517	2 ¹ / ₂	1 ¹ / ₂	1 ³ / ₄	2 ³ / ₃₂	12.0
8 3V 650 TB	6.50	6.45	A-1	2517	2 ¹ / ₂	1 ¹ / ₄	1 ³ / ₄	1 ¹⁷ / ₃₂	13.0	10 3V 650 TB	A-1	2517	2 ¹ / ₂	1 ¹ / ₂	1 ³ / ₄	2 ³ / ₃₂	14.0
8 3V 690 TB	6.90	6.85	A-1	2517	2 ¹ / ₂	1 ¹ / ₄	1 ³ / ₄	1 ¹⁷ / ₃₂	15.0	10 3V 690 TB	A-1	2517	2 ¹ / ₂	1 ¹ / ₂	1 ³ / ₄	2 ³ / ₃₂	17.0
8 3V 800 TB	8.00	7.95	A-1	3020	3	1 ¹ / ₂	2	1 ¹ / ₃₂	19.0	10 3V 800 TB	A-1	3020	3	1 ¹ / ₄	2	2 ³ / ₃₂	22.0
8 3V 1060 TB	10.60	10.55	A-2	3020	3	1 ¹ / ₂	2	1 ¹ / ₃₂	26.0	10 3V 1060 TB	A-2	3020	3	2 ⁷ / ₃₂	2	1 ¹ / ₂	32.0
8 3V 1400 TB	14.00	13.95	A-3	3020	3	2 ³ / ₃₂	2	7 ¹ / ₈	52.0	10 3V 1400 TB	A-2	3535	3 ¹ / ₂	0	3 ¹ / ₂	2 ⁷ / ₃₂	59.0
8 3V 1900 TB	19.00	18.95	A-3	3535	3 ¹ / ₂	0	3 ¹ / ₂	1 ¹ / ₃₂	63.0	10 3V 1900 TB	A-3	3535	3 ¹ / ₂	0	3 ¹ / ₂	2 ⁷ / ₃₂	71.0
8 3V 2500 TB	25.00	24.95	A-3	3535	3 ¹ / ₂	0	3 ¹ / ₂	1 ¹ / ₃₂	89.0	10 3V 2500 TB	A-3	4040	4	0	4	1 ¹ / ₃₂	121.0
8 3V 3350 TB	33.50	33.45	C-3	4040	4	1 ⁵ / ₆₄	4	1 ⁵ / ₆₄	131.0	10 3V 3350 TB	A-3	4040	4	1 ¹ / ₆₄	4	1 ¹ / ₃₂	172.0

PLEASE NOTE: Dashes are REQUIRED in place of spaces when ordering or searching on PTplace.com.

5V | Taper Bushed Sheaves

Hi-Cap® Wedge

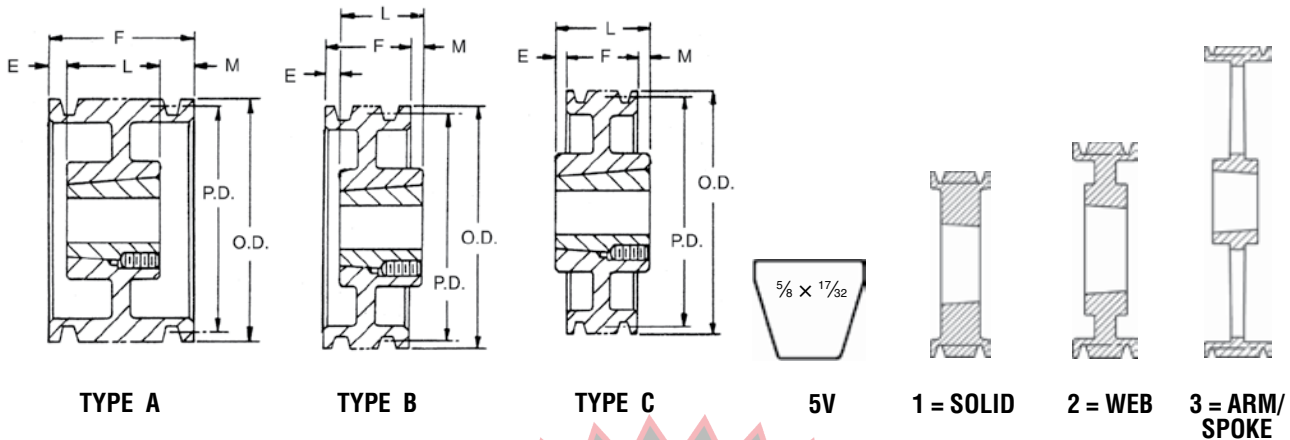

Taper Bushed Sheaves — 5V

Nomenclature Example: **2-5V-710-TB**

2 Groove F = 1 ¹¹ / ₁₆										3 Groove F = 2 ³ / ₈							
Part Number	Diameter		Type	Bush	Bush Max. Bore	E	L Thru Bore	M	Wt. Less Bush	Part Number	Type	Bush	Bush Max. Bore	E	L Thru Bore	M	Wt. Less Bush
	OD	Pitch 5V															
* 2 5V 440 TB	4.4	4.30	A-1	1610	1%	1/16	1	5/8	3.0	* 3 5V 440 TB	A-1	1610	1%	1%	1	0	4.0
* 2 5V 465 TB	4.65	4.55	A-1	1610	1%	1/16	1	5/8	3.0	* 3 5V 465 TB	A-1	1610	1%	1/8	1	1/16	5.0
* 2 5V 490 TB	4.9	4.80	A-1	1610	1%	1/16	1	5/8	4.0	* 3 5V 490 TB	A-1	1610	1%	1/8	1	1/16	5.0
* 2 5V 520 TB	5.2	5.10	A-1	1610	1%	1/16	1	5/8	4.2	* 3 5V 520 TB	A-1	1610	1%	1/8	1	1/16	6.0
* 2 5V 550 TB	5.5	5.40	A-1	1610	1%	1/16	1	5/8	5.2	* 3 5V 550 TB	A-1	1610	1%	1/8	1	1/16	6.0
* 2 5V 590 TB	5.9	5.8	A-1	1610	1%	1/16	1	5/8	5.6	* 3 5V 590 TB	A-1	2517	2%	0	1 3/4	5/8	7.0
* 2 5V 630 TB	6.3	6.20	A-1	1610	1%	0	1	1 1/16	7.6	* 3 5V 630 TB	A-1	2517	2%	0	1 3/4	5/8	9.0
* 2 5V 670 TB	6.7	6.60	A-1	1610	1%	0	1	1 1/16	9.4	* 3 5V 670 TB	A-1	2517	2%	0	1 3/4	5/8	10.0
2 5V 710 TB	7.10	7.00	B-1	2517	2 1/2	1/16	1 3/4	0	10.0	* 3 5V 710 TB	A-1	2517	2 1/2	5/8	1 3/4	0	11.0
2 5V 750 TB	7.50	7.40	B-1	2517	2 1/2	1/16	1 3/4	0	13.0	* 3 5V 750 TB	A-1	2517	2 1/2	5/8	1 3/4	0	14.0
2 5V 800 TB	8.00	7.90	B-1	2517	2 1/2	1/16	1 3/4	0	14.0	3 5V 800 TB	A-1	2517	2 1/2	5/8	1 3/4	0	16.0
2 5V 850 TB	8.50	8.40	B-2	2517	2 1/2	1/16	1 3/4	0	15.0	3 5V 850 TB	A-2	2517	2 1/2	5/8	1 3/4	0	17.0
2 5V 900 TB	9.00	8.90	B-2	2517	2 1/2	1/16	1 3/4	0	16.0	3 5V 900 TB	A-2	2517	2 1/2	5/8	1 3/4	0	19.0
2 5V 925 TB	9.25	9.15	B-2	3020	3	0	2	5/16	17.0	3 5V 925 TB	A-1	3020	3	0	2	5/8	23.0
2 5V 975 TB	9.75	9.65	B-2	3020	3	0	2	5/16	18.0	3 5V 975 TB	A-1	3020	3	0	2	5/8	24.0
2 5V 1030 TB	10.30	10.20	B-2	3020	3	0	2	5/16	20.0	3 5V 1030 TB	A-2	3020	3	0	2	5/8	27.0
2 5V 1090 TB	10.90	10.80	B-2	3020	3	0	2	5/16	22.0	3 5V 1090 TB	A-2	3020	3	0	2	5/8	28.0
2 5V 1180 TB	11.80	11.70	B-2	3020	3	0	2	5/16	26.0	3 5V 1180 TB	A-2	3020	3	0	2	5/8	30.0
2 5V 1250 TB	12.50	12.40	B-2	3020	3	0	2	5/16	28.0	3 5V 1250 TB	A-2	3020	3	0	2	5/8	32.0
2 5V 1320 TB	13.20	13.10	B-3	3020	3	0	2	5/16	29.0	3 5V 1320 TB	A-2	3020	3	0	2	5/8	34.0
2 5V 1400 TB	14.00	13.90	B-3	3020	3	0	2	5/16	33.0	3 5V 1400 TB	A-3	3020	3	0	2	5/8	36.0
2 5V 1500 TB	15.00	14.90	B-3	3020	3	0	2	5/16	35.0	3 5V 1500 TB	A-3	3020	3	0	2	5/8	41.0
2 5V 1600 TB	16.00	15.90	B-3	3020	3	0	2	5/16	45.0	3 5V 1600 TB	A-3	3020	3	0	2	5/8	50.0
2 5V 1870 TB	18.7	18.60	C-3	3020	3	0	2	5/16	50.1	3 5V 1870 TB	A-3	3020	3	0	2	5/8	52.0
2 5V 2120 TB	21.20	21.10	C-3	3535	3 1/2	5/8	3 1/2	1 1/16	60.0	3 5V 2120 TB	B-3	3535	3 1/2	0	3 1/2	1 1/8	65.0
2 5V 2360 TB	23.6	23.50	C-3	3535	3 1/2	1/4	3 1/2	1 1/16	68.0	3 5V 2360 TB	C-3	3535	3 1/2	0	3 1/2	1 1/8	68.0
2 5V 2800 TB	28.00	27.90	C-3	3535	3 1/2	5/8	3 1/2	1 1/16	96.0	3 5V 2800 TB	B-3	3535	3 1/2	0	3 1/2	1 1/8	99.0
										3 5V 3150 TB	C-3	3535	3 1/2	1 1/32	3 1/2	5/16	96.0
										3 5V 3750 TB	C-3	4040	4	1/2	4	1 1/8	172.0
										3 5V 5000 TB	C-3	4040	4	1/2	4	1 1/8	201.0

Dimensions in inches, weight in pounds. Weights do not include bushings. See page B-8 thru B-10 for additional bushing dimensions.
* 5VX Belts only on these sizes.

PLEASE NOTE: Dashes are REQUIRED in place of spaces when ordering or searching on PTplace.com.

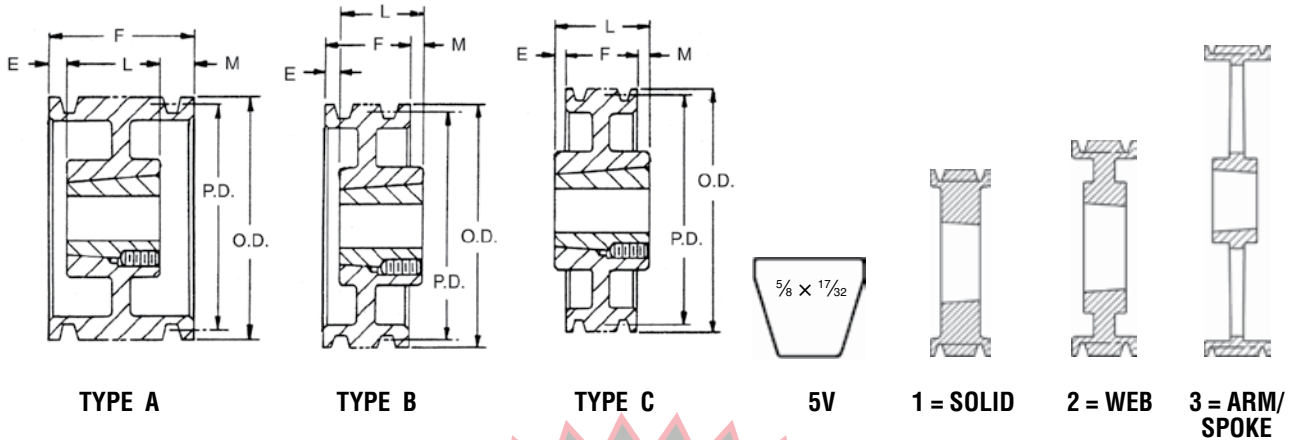

Taper Bushed Sheaves — 5V

Nomenclature Example: 4-5V-710-TB

4 Groove F = 3/16										5 Groove F = 3/8							
Part Number	Diameter		Type	Bush	Bush Max. Bore	E	L Thru Bore	M	Wt. Less Bush	Part Number	Type	Bush	Bush Max. Bore	E	L Thru Bore	M	Wt. Less Bush
	OD	Pitch 5V															
*4 5V 440 TB	4.4	4.30	A-1	1610	1%	2 5/16	1	0	6.0								
*4 5V 465 TB	4.65	4.55	A-1	1610	1%	2 5/16	1	0	6.0								
*4 5V 490 TB	4.9	4.80	A-1	1610	1%	2 5/16	1	0	6.0								
*4 5V 520 TB	5.2	5.10	A-1	1610	1%	2 5/16	1	0	7.0								
*4 5V 550 TB	5.5	5.40	A-1	2517	2 1/2	1 5/8	1 1/4	0	8.0								
*4 5V 590 TB	5.9	5.80	A-1	2517	2 1/2	1 5/8	1 1/4	0	10.0	*5 5V 590 TB	A-1	2517	2 1/2	5/8	1 1/4	1 1/8	11.0
*4 5V 630 TB	6.3	6.20	A-1	2517	2 1/2	0	1 1/4	1 1/8	11.0	*5 5V 630 TB	A-1	2517	2 1/2	5/8	1 1/4	1 1/8	12.0
*4 5V 670 TB	6.7	6.60	A-1	2517	2 1/2	0	1 1/4	1 1/8	12.0	*5 5V 670 TB	A-1	2517	2 1/2	5/8	1 1/4	1 1/8	13.0
4 5V 710 TB	7.10	7.00	A-1	2517	2 1/2	1 5/8	1 1/4	0	14.0	5 5V 710 TB	A-1	3020	3	1/2	2	1 1/4	15.0
4 5V 750 TB	7.50	7.40	A-1	2517	2 1/2	1 5/8	1 1/4	0	16.0	5 5V 750 TB	A-1	3020	3	1/2	2	1 1/4	17.0
4 5V 800 TB	8.00	7.90	A-1	2517	2 1/2	1 5/8	1 1/4	0	17.0	5 5V 800 TB	A-1	3020	3	1/2	2	1 1/4	20.0
4 5V 850 TB	8.50	8.40	A-2	2517	2 1/2	1 5/8	1 1/4	0	18.0	5 5V 850 TB	A-1	3020	3	1/2	2	1 1/4	22.0
4 5V 900 TB	9.00	8.90	A-2	2517	2 1/2	1 5/8	1 1/4	0	19.0	5 5V 900 TB	A-1	3020	3	1/2	2	1 1/4	30.0
4 5V 925 TB	9.25	9.15	A-1	3020	3	1 1/2	2	5/16	22.0	5 5V 925 TB	A-1	3020	3	1/2	2	1 1/4	36.0
4 5V 975 TB	9.75	9.65	A-1	3020	3	1 1/2	2	5/16	27.0	5 5V 975 TB	A-1	3020	3	1/2	2	1 1/4	37.0
4 5V 1030 TB	10.30	10.20	A-2	3020	3	1 1/2	2	5/16	28.0	5 5V 1030 TB	A-2	3020	3	1/2	2	1 1/4	38.0
4 5V 1090 TB	10.90	10.80	A-2	3020	3	1 1/2	2	5/16	31.0	5 5V 1090 TB	A-2	3020	3	1/2	2	1 1/4	39.0
4 5V 1130 TB	11.3	11.20	A-1	3020	3	0	2	1 1/8	32.0	5 5V 1130 TB	A-1	3020	3	1/2	2	1 1/4	38.0
4 5V 1180 TB	11.80	11.70	A-2	3020	3	1 1/2	2	5/16	35.0	5 5V 1180 TB	A-2	3020	3	1/2	2	1 1/4	40.0
4 5V 1250 TB	12.50	12.40	A-2	3020	3	0	2	1 1/8	44.0	5 5V 1250 TB	A-2	3535	3 1/2	0	3 1/2	1/4	50.0
4 5V 1320 TB	13.20	13.10	A-3	3020	3	0	2	1 1/8	42.0	5 5V 1320 TB	A-2	3535	3 1/2	0	3 1/2	1/4	56.0
4 5V 1400 TB	14.00	13.90	B-3	3535	3 1/2	0	3 1/2	7/16	53.0	5 5V 1400 TB	A-3	3535	3 1/2	0	3 1/2	1/4	58.0
4 5V 1500 TB	15.00	14.90	B-3	3535	3 1/2	0	3 1/2	7/16	54.0	5 5V 1500 TB	A-3	3535	3 1/2	0	3 1/2	1/4	65.0
4 5V 1600 TB	16.00	15.90	B-3	3535	3 1/2	0	3 1/2	7/16	60.0	5 5V 1600 TB	A-3	3535	3 1/2	0	3 1/2	1/4	70.0
4 5V 1870 TB	18.7	18.60	C-3	3535	3 1/2	7/16	3 1/2	0	63.0	5 5V 1870 TB	A-3	3535	3 1/2	0	3 1/2	1/4	84.0
4 5V 2120 TB	21.20	21.10	B-3	3535	3 1/2	0	3 1/2	7/16	72.0	5 5V 2120 TB	B-3	4040	4	0	4	1/4	115.0
4 5V 2360 TB	23.6	23.50	C-3	3535	3 1/2	0	3 1/2	7/16	79.0	5 5V 2360 TB	C-3	4040	4	0	4	1/4	92.0
4 5V 2800 TB	28.00	27.90	B-3	3535	3 1/2	0	3 1/2	7/16	125.0	5 5V 2800 TB	B-3	4040	4	0	4	1/4	160.0
4 5V 3150 TB	31.5	31.40	C-3	3535	3 1/2	0	3 1/2	7/16	114.0	5 5V 3150 TB	A-3	4040	4	0	4	1/4	155.0
4 5V 3750 TB	37.50	37.40	B-3	4040	4	0	4	15/16	189.0	5 5V 3750 TB	B-3	4040	4	0	4	1/4	182.0
4 5V 5000 TB	50.00	49.90	B-3	4040	4	0	4	15/16	371.0	5 5V 5000 TB	B-3	4545	4 1/2	0	4 1/2	1/4	288.0

Dimensions in inches, weight in pounds. Weights do not include bushings. See page B-8 thru B-10 for additional bushing dimensions.
 * 5VX Belts only on these sizes.

PLEASE NOTE: Dashes are REQUIRED in place of spaces when ordering or searching on PTplace.com.

V-Belt | Taper Bushed Sheaves

Taper Bushed Sheaves — 5V

Nomenclature Example: **6-5V-710-TB**

6 Groove										8 Groove							
F = 4 ⁷ / ₁₆										F = 5 ¹³ / ₁₆							
Part Number	Diameter		Type	Bush	Bush Max. Bore	E	L Thru Bore	M	Wt. Less Bush	Part Number	Type	Bush	Bush Max. Bore	E	L Thru Bore	M	Wt. Less Bush
	OD	Pitch 5V															
* 6 5V 590 TB	5.90	5.80	A-1	2517	2 ¹ / ₂	1 ¹ / ₂	1 ³ / ₄	1 ¹ / ₁₆	13.0								
* 6 5V 630 TB	6.30	6.20	A-1	2517	2 ¹ / ₂	1 ³ / ₁₆	1 ³ / ₄	1 ¹ / ₁₆	13.0								
* 6 5V 670 TB	6.70	6.60	A-1	2517	2 ¹ / ₂	1 ³ / ₁₆	1 ³ / ₄	1 ¹ / ₁₆	15.0								
6 5V 710 TB	7.10	7.00	A-1	3020	3	3	2	1 ¹ / ₁₆	17.0	8 5V 710 TB	A-1	3030	3	1	3	1 ¹ / ₁₆	24.0
6 5V 750 TB	7.50	7.40	A-1	3020	3	3	2	1 ¹ / ₁₆	20.0	8 5V 750 TB	A-1	3030	3	1	3	1 ¹ / ₁₆	27.0
6 5V 800 TB	8.00	7.90	A-1	3020	3	3	2	1 ¹ / ₁₆	24.0	8 5V 800 TB	A-1	3030	3	1	3	1 ¹ / ₁₆	33.0
6 5V 850 TB	8.50	8.40	A-1	3020	3	3	2	1 ¹ / ₁₆	28.0	8 5V 850 TB	A-1	3030	3	1	3	1 ¹ / ₁₆	39.0
6 5V 900 TB	9.00	8.90	A-1	3020	3	3	2	1 ¹ / ₁₆	32.0	8 5V 900 TB	A-1	3535	3 ¹ / ₂	1	3 ¹ / ₂	1 ¹ / ₁₆	44.0
6 5V 925 TB	9.25	9.15	A-1	3535	3 ¹ / ₂	0	3 ¹ / ₂	1 ¹ / ₁₆	39.0	8 5V 925 TB	A-1	3535	3 ¹ / ₂	1	3 ¹ / ₂	1 ¹ / ₁₆	48.0
6 5V 975 TB	9.75	9.65	A-1	3535	3 ¹ / ₂	0	3 ¹ / ₂	1 ¹ / ₁₆	50.0	8 5V 975 TB	A-1	3535	3 ¹ / ₂	1	3 ¹ / ₂	1 ¹ / ₁₆	55.0
6 5V 1030 TB	10.30	10.20	A-1	3535	3 ¹ / ₂	0	3 ¹ / ₂	1 ¹ / ₁₆	58.0	8 5V 1030 TB	A-1	3535	3 ¹ / ₂	1	3 ¹ / ₂	1 ¹ / ₁₆	64.0
6 5V 1090 TB	10.90	10.80	A-1	3535	3 ¹ / ₂	0	3 ¹ / ₂	1 ¹ / ₁₆	60.0	8 5V 1090 TB	A-1	3535	3 ¹ / ₂	1	3 ¹ / ₂	1 ¹ / ₁₆	68.0
	11.30	11.20								8 5V 1130 TB	A-1	3535	3 ¹ / ₂	1	3 ¹ / ₂	1 ¹ / ₁₆	57.0
6 5V 1180 TB	11.80	11.70	A-2	3535	3 ¹ / ₂	0	3 ¹ / ₂	1 ¹ / ₁₆	62.0	8 5V 1180 TB	A-1	3535	3 ¹ / ₂	1	3 ¹ / ₂	1 ¹ / ₁₆	74.0
6 5V 1250 TB	12.50	12.40	A-2	3535	3 ¹ / ₂	0	3 ¹ / ₂	1 ¹ / ₁₆	65.0	8 5V 1250 TB	A-1	4040	4	1	4	1 ¹ / ₁₆	82.0
6 5V 1320 TB	13.20	13.10	A-2	3535	3 ¹ / ₂	0	3 ¹ / ₂	1 ¹ / ₁₆	68.0	8 5V 1320 TB	A-1	4040	4	1	4	1 ¹ / ₁₆	87.0
6 5V 1400 TB	14.00	13.90	A-2	3535	3 ¹ / ₂	0	3 ¹ / ₂	1 ¹ / ₁₆	72.0	8 5V 1400 TB	A-2	4040	4	1	4	1 ¹ / ₁₆	90.0
6 5V 1500 TB	15.00	14.90	A-2	4040	4	0	4	7	91.0	8 5V 1500 TB	A-2	4040	4	1	4	1 ¹ / ₁₆	97.0
6 5V 1600 TB	16.00	15.90	A-3	4040	4	0	4	7	97.0	8 5V 1600 TB	A-3	4040	4	1	4	1 ¹ / ₁₆	106.0
6 5V 1870 TB	18.70	18.60	A-2	4040	4	0	4	7	97.0	8 5V 1870 TB	A-3	4040	4	1	4	1 ¹ / ₁₆	112.0
6 5V 2120 TB	21.20	21.10	A-3	4040	4	0	4	7	123.0	8 5V 2120 TB	A-3	4040	4	1	4	1 ¹ / ₁₆	144.0
6 5V 2360 TB	23.60	23.50	A-3	4040	4	0	4	7	124.0	8 5V 2360 TB	A-3	4040	4	1	4	1 ¹ / ₁₆	145.0
6 5V 2800 TB	28.00	27.90	A-3	4040	4	0	4	7	176.0	8 5V 2800 TB	A-3	4545	4 ¹ / ₂	1	4 ¹ / ₂	1 ¹ / ₁₆	206.0
6 5V 3150 TB	31.50	31.40	A-3	4040	4	0	4	7	171.0	8 5V 3150 TB	A-3	4545	4 ¹ / ₂	1	4 ¹ / ₂	1 ¹ / ₁₆	228.0
6 5V 3750 TB	37.50	37.40	B-3	4545	4 ¹ / ₂	0	4 ¹ / ₂	1	254.0	8 5V 3750 TB	A-3	4545	4 ¹ / ₂	1	4 ¹ / ₂	1 ¹ / ₁₆	271.0
6 5V 5000 TB	50.00	49.90	B-3	4545	4 ¹ / ₂	0	4 ¹ / ₂	1	386.0	8 5V 5000 TB	A-3	4545	4 ¹ / ₂	1	4 ¹ / ₂	1 ¹ / ₁₆	458.0

Taper Bushed Sheaves — 5V

Example: **10-5V-800-TB**

PLEASE NOTE: Dashes are REQUIRED in place of spaces when ordering or searching on PTplace.com.

10 Groove									
F = 7 ³ / ₁₆									
Part Number	Diameter		Type	Bush	Bush Max. Bore	E	L Thru Bore	M	Wt. Less Bush
	OD	Pitch 5V							
10 5V 800 TB	8.00	7.90	A-1	3030	3	1	3	3 ³ / ₁₆	36.0
10 5V 850 TB	8.50	8.40	A-1	3030	3	1	3	3 ³ / ₁₆	42.0
10 5V 900 TB	9.00	8.90	A-1	3535	3 ¹ / ₂	1	3 ¹ / ₂	2 ¹ / ₁₆	47.0
10 5V 925 TB	9.25	9.15	A-1	4040	4	1	4	2 ³ / ₁₆	50.0
10 5V 975 TB	9.75	9.65	A-1	4040	4	1	4	2 ³ / ₁₆	58.0
10 5V 1030 TB	10.30	10.20	A-1	4040	4	1	4	2 ³ / ₁₆	69.0
10 5V 1090 TB	10.90	10.80	A-1	4040	4	1	4	2 ³ / ₁₆	79.0
10 5V 1130 TB	11.30	11.20	A-1	4040	4	1	4	2 ³ / ₁₆	80.0
10 5V 1180 TB	11.80	11.70	A-1	4040	4	1	4	2 ³ / ₁₆	96.0
10 5V 1250 TB	12.50	12.40	A-2	4040	4	3	4	2 ¹ / ₁₆	116.0
10 5V 1320 TB	13.20	13.10	A-2	4040	4	3	4	2 ¹ / ₁₆	130.0
10 5V 1400 TB	14.00	13.90	A-2	4545	4 ¹ / ₂	3	4 ¹ / ₂	1 ¹ / ₁₆	150.0
10 5V 1500 TB	15.00	14.90	A-2	4545	4 ¹ / ₂	3	4 ¹ / ₂	1 ¹ / ₁₆	155.0
10 5V 1600 TB	16.00	15.90	A-2	4545	4 ¹ / ₂	3	4 ¹ / ₂	1 ¹ / ₁₆	160.0
10 5V 1870 TB	18.70	18.60	A-2	4545	4 ¹ / ₂	1	4 ¹ / ₂	2 ³ / ₁₆	116.0
10 5V 2120 TB	21.20	21.10	A-3	4545	4 ¹ / ₂	3	4 ¹ / ₂	1 ¹ / ₁₆	210.0
10 5V 2360 TB	23.60	23.50	A-2	4545	4 ¹ / ₂	1	4 ¹ / ₂	2 ³ / ₁₆	191.0
10 5V 2800 TB	28.00	27.90	A-3	4545	4 ¹ / ₂	3	4 ¹ / ₂	1 ¹ / ₁₆	248.0
10 5V 3150 TB	31.50	31.40	A-3	4545	4 ¹ / ₂	3	4 ¹ / ₂	1 ¹ / ₁₆	259.0
10 5V 3750 TB	37.50	37.40	A-3	4545	4 ¹ / ₂	3	4 ¹ / ₂	1 ¹ / ₁₆	375.0
10 5V 5000 TB	50.00	49.90	A-3	5050	5	3	5	1 ¹ / ₁₆	502.0

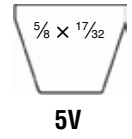

Dimensions in inches, weight in pounds. Weights do not include bushings. See page B-8 thru B-10 for additional bushing dimensions.
 * 5VX Belts only on these sizes.

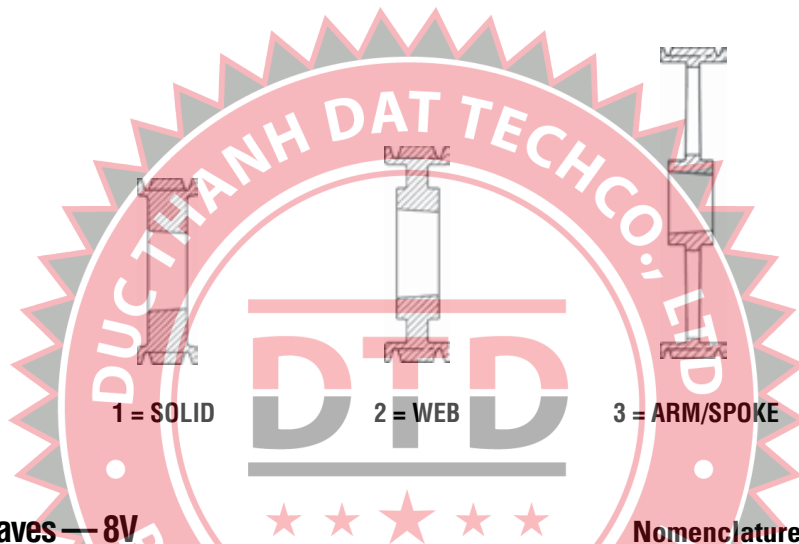
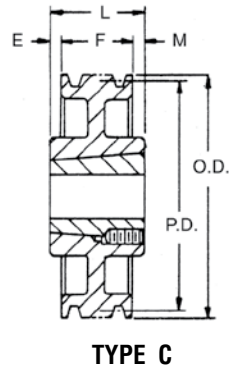
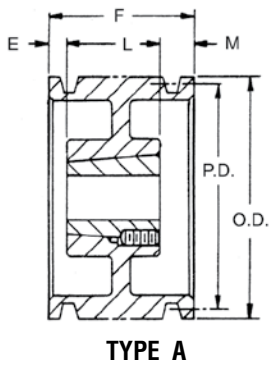

V-Belt | Taper Bushed Sheaves

Taper Bushed Sheaves — 8V

Nomenclature Example: 4-8V-1250-TB

4 Groove F = 4%										5 Groove F = 6							
Part Number	Diameters		Type	Bush	Bush Max. Bore	E	L Thru Bore	M	Wt. Less Bush	Part Number	Type	Bush	Bush Max. Bore	E	L Thru Bore	M	Wt. Less Bush
	OD	Pitch 8V															
4 8V 1250 TB	12.5	12.3	A-1	4040	4	0	4	7/8	88.0	5 8V 1250 TB	A-1	4040	4	3/16	4	1 15/16	100.0
4 8V 1320 TB	13.2	13.0	A-1	4040	4	0	4	7/8	102.0	5 8V 1320 TB	A-1	4040	4	3/16	4	1 15/16	115.0
4 8V 1400 TB	14.0	13.8	A-1	4040	4	0	4	7/8	123.0	5 8V 1400 TB	A-1	4040	4	3/16	4	1 15/16	133.0
4 8V 1500 TB	15.0	14.8	A-1	4040	4	0	4	7/8	145.0	5 8V 1500 TB	A-1	4040	4	3/16	4	1 15/16	156.0
4 8V 1600 TB	16.0	15.8	A-2	4040	4	0	4	7/8	111.0	5 8V 1600 TB	A-1	4040	4	1/2	4	1 1/2	181.0
4 8V 1700 TB	17.0	16.8	A-2	4040	4	0	4	7/8	120.0	5 8V 1700 TB	A-2	4545	4 1/2	0	4 1/2	1 1/2	146.0
4 8V 1800 TB	18.0	17.8	A-2	4040	4	0	4	7/8	130.0	5 8V 1800 TB	A-2	4545	4 1/2	0	4 1/2	1 1/2	156.0
4 8V 1900 TB	19.0	18.8	A-2	4040	4	0	4	7/8	140.0	5 8V 1900 TB	A-2	4545	4 1/2	0	4 1/2	1 1/2	176.0
4 8V 2000 TB	20.0	19.8	A-2	4545	4 1/2	0	4 1/2	7/8	151.0	5 8V 2000 TB	A-2	4545	4 1/2	0	4 1/2	1 1/2	186.0
4 8V 2120 TB	21.2	21.0	A-3	4545	4 1/2	0	4 1/2	3/4	154.0	5 8V 2120 TB	A-3	4545	4 1/2	0	4 1/2	1 1/2	195.0
4 8V 2240 TB	22.4	22.2	A-3	4545	4 1/2	0	4 1/2	3/4	185.0	5 8V 2240 TB	A-3	4545	4 1/2	0	4 1/2	1 1/2	200.0
4 8V 2480 TB	24.8	24.6	D-3	5050	5	15/16	5	13/16	191.0	5 8V 2480 TB	A-3	5050	5	0	5	1 1/2	206.0
4 8V 3000 TB	30.0	29.8	C-3	5050	5	0	5	1	246.0	5 8V 3000 TB	A-3	5050	5	0	5	1	278.0
4 8V 3550 TB	35.5	35.3	D-3	5050	5	1 1/8	5	1	278.0	5 8V 3550 TB	A-3	5050	5	0	5	1	399.0
4 8V 4000 TB	40.0	39.8	B-3	5050	5	0	5	1	292.0	5 8V 4000 TB	A-3	5050	5	0	5	1	350.0
4 8V 4450 TB	44.5	44.3	D-3	5050	5	1/4	5	1	367.0	5 8V 4450 TB	A-3	5050	5	0	5	1	572.0
4 8V 5300 TB	53.0	52.8	B-3	5050	5	0	5	1	573.0	5 8V 5300 TB	A-3	5050	5	0	5	1	565.0

Dimensions in inches, weight in pounds. Weights do not include bushings. See page B-8 thru B-10 for additional bushing dimensions.

PLEASE NOTE: Dashes are REQUIRED in place of spaces when ordering or searching on PTplace.com.

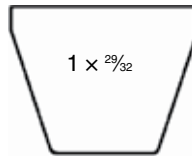

8V

Taper Bushed Sheaves — 8V

Nomenclature Example: 6-8V-1250-TB

6 Groove F = 6%										8 Groove F = 9%							
Part Number	Diameters		Type	Bush	Bush Max. Bore	E	L Thru Bore	M	Wt. Less Bush	Part Number	Type	Bush	Bush Max. Bore	E	L Thru Bore	M	Wt. Less Bush
	OD	Pitch 8V															
6 8V 1250 TB	12.5	12.3	A-1	4040	4	1	4	2%	100.0	8 8V 1250 TB	A-1	4545	4½	1½	4½	3%	125.0
6 8V 1320 TB	13.2	13.0	A-1	4040	4	1	4	2%	124.0	8 8V 1320 TB	A-1	4545	4½	1½	4½	3%	135.0
6 8V 1400 TB	14.0	13.8	A-1	4040	4	1	4	2%	142.0	8 8V 1400 TB	A-1	4545	4½	1½	4½	3%	156.0
6 8V 1500 TB	15.0	14.8	A-1	4545	4½	½	4½	2%	153.0	8 8V 1500 TB	A-1	4545	4½	1½	4½	3%	160.0
6 8V 1600 TB	16.0	15.8	A-2	4545	4½	½	4½	2%	170.0	8 8V 1600 TB	A-2	4545	4½	1½	4½	3%	166.0
6 8V 1700 TB	17.0	16.8	A-2	4545	4½	½	4½	2%	175.0	8 8V 1700 TB	A-2	5050	5	1	5	3%	265.0
6 8V 1800 TB	18.0	17.8	A-2	4545	4½	½	4½	2%	180.0	8 8V 1800 TB	A-2	5050	5	1	5	3%	204.0
6 8V 1900 TB	19.0	18.8	A-2	4545	4½	½	4½	2%	182.0	8 8V 1900 TB	A-2	5050	5	1	5	3%	228.0
6 8V 2000 TB	20.0	19.8	A-2	5050	5	½	5	1%	226.0	8 8V 2000 TB	A-2	5050	5	1	5	3%	234.0
6 8V 2120 TB	21.2	21.0	A-3	5050	5	½	5	1%	246.0	8 8V 2120 TB	A-3	5050	5	1	5	3%	246.0
6 8V 2240 TB	22.4	22.2	A-3	5050	5	½	5	1%	267.0	8 8V 2240 TB	A-3	5050	5	1	5	3%	300.0
6 8V 2480 TB	24.8	24.6	D-3	5050	5	½	5	2%	236.0	8 8V 2480 TB	A-3	5050	5	2%	5	2%	285.0
6 8V 3000 TB	30.0	29.8	A-3	5050	5	½	5	1%	398.0	8 8V 3000 TB	A-3	5050	5	1	5	3%	384.0
6 8V 3550 TB	35.5	35.3	A-3	5050	5	½	5	1%	363.0	8 8V 3550 TB	A-3	5050	5	1	5	3%	441.0
6 8V 4000 TB	40.0	39.8	A-3	5050	5	½	5	1%	468.0	8 8V 4000 TB	A-3	5050	5	1	5	3%	556.0
6 8V 4450 TB	44.5	44.3	A-3	5050	5	½	5	1%	485.0	8 8V 4450 TB	A-3	6050	5	1	5	3%	596.0
6 8V 5300 TB	53.0	52.8	A-3	5050	5	½	5	1%	658.0	8 8V 5300 TB	A-3	6050	6	1	5	3%	1040.0

10 Groove F = 11%										12 Groove F = 13%							
Part Number	Diameters		Type	Bush	Bush Max. Bore	E	L Thru Bore	M	Wt. Less Bush	Part Number	Type	Bush	Bush Max. Bore	E	L Thru Bore	M	Wt. Less Bush
	OD	Pitch 8V															
10 8V 1320 TB	12.5	12.3	A-1	4545	4½	1	4½	6%	150.0	12 8V 1250 TB	A-1	5050	5	3%	5	5 1/16	153.0
10 8V 1400 TB	14.0	13.8	A-1	4545	4½	1	4½	6%	180.0	12 8V 1320 TB	A-1	5050	5	3	5	5%	180.0
10 8V 1500 TB	15.0	14.8	A-1	5050	5	1	5	5%	211.0	12 8V 1400 TB	A-1	5050	5	3%	5	5 1/16	186.0
10 8V 1600 TB	16.0	15.8	A-1	5050	5	1	5	5%	220.0	12 8V 1500 TB	A-2	5050	5	1%	5	7	221.0
10 8V 1700 TB	17.0	16.8	A-2	5050	5	2%	5	4%	228.0	12 8V 1600 TB	A-2	5050	5	1%	5	7	247.0
10 8V 1800 TB	18.0	17.8	A-2	5050	5	2%	5	4%	244.0	12 8V 1700 TB	A-2	5050	5	3%	5	5%	267.0
10 8V 1900 TB	19.0	18.8	A-2	5050	5	2%	5	4%	260.0	12 8V 1800 TB	A-2	5050	5	3 1/2	5	5 1/2	274.0
10 8V 2000 TB	20.0	19.8	A-2	5050	5	2%	5	4%	270.0	12 8V 1900 TB	A-2	5050	5	2%	5	6%	306.0
10 8V 2120 TB	21.2	21.0	A-2	5050	5	2%	5	4%	282.0	12 8V 2000 TB	A-3	5050	5	2%	5	6%	249.0
10 8V 2240 TB	22.4	22.2	A-3	5050	5	2%	5	4%	312.0	12 8V 2120 TB	A-3	5050	5	2%	5	6%	294.0
10 8V 2480 TB	24.8	24.6	A-3	5050	5	2%	5	4%	328.0	12 8V 2240 TB	A-3	5050	5	2%	5	6%	337.0
10 8V 3000 TB	30.0	29.8	A-3	5050	5	2%	5	4%	448.0	12 8V 2480 TB	A-3	5050	5	5%	5	3%	380.0
10 8V 3550 TB	35.5	35.3	A-3	6050	6	2%	5	4%	517.0	12 8V 3000 TB	A-3	6050	6	4	5	4%	482.0
10 8V 4000 TB	40.0	39.8	A-3	6050	6	2%	5	4%	550.0	12 8V 3550 TB	A-3	6050	6	4	5	4%	597.0
10 8V 4450 TB	44.5	44.3	A-3	6050	6	2%	5	4%	701.0	12 8V 4000 TB	A-3	6050	6	4	5	4%	702.0
10 8V 5300 TB	53.0	52.8	A-3	6050	6	2%	5	4%	870.0	12 8V 4450 TB	A-3	6050	6	4	5	4%	814.0
										12 8V 5300 TB	A-3	7060	6	5	5	2%	1077.0

Dimensions in inches, weight in pounds. Weights do not include bushings. See page B-8 thru B-10 for additional bushing dimensions.

PLEASE NOTE: Dashes are REQUIRED in place of spaces when ordering or searching on PTplace.com.

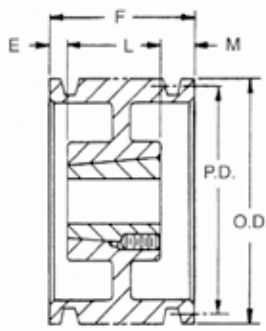

TYPE A

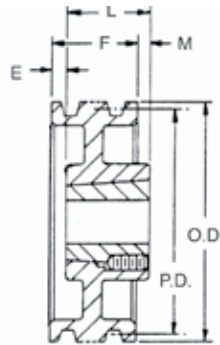

TYPE B

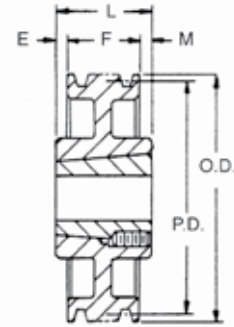

TYPE C

Taper Bushed Sheaves — A-B

Nomenclature Example: **1-B-34-TB**

1 Groove F = 1*										2 Groove F = 1%								
Part Number	Pitch Diameters		OD	Type	Bush	Bush Max. Bore	E	L Thru Bore	M	Wt. Less Bush	Part Number	Type	Bush	Bush Max. Bore	E	L Thru Bore	M	Wt. Less Bush
	A Belt	B Belt																
1 B 34 TB	3.0	3.4	3.75	A-1	1210	1%	0	1	0	2.2	2 B 34 TB	A-1	1210	1%	0	1	0	2.2
1 B 36 TB	3.2	3.6	3.95	A-1	1210	1%	0	1	0	2.6	2 B 36 TB	A-1	1210	1%	0	1	0	2.6
1 B 38 TB	3.4	3.8	4.15	A-1	1610	1%	0	1	0	2.8	2 B 38 TB	A-1	1610	1%	0	1	0	2.8
1 B 40 TB	3.6	4.0	4.35	A-1	1610	1%	0	1	0	3.0	2 B 40 TB	A-1	1610	1%	0	1	0	3.0
1 B 42 TB	3.8	4.2	4.55	A-1	1610	1%	0	1	0	3.5	2 B 42 TB	A-1	1610	1%	0	1	0	4.0
1 B 44 TB	4.0	4.4	4.75	A-1	1610	1%	0	1	0	3.8	2 B 44 TB	A-1	1610	1%	0	1	0	4.5
1 B 46 TB	4.2	4.6	4.95	A-1	1610	1%	0	1	0	4.0	2 B 46 TB	A-1	1610	1%	0	1	0	5.0
1 B 48 TB	4.4	4.8	5.15	A-1	1610	1%	0	1	0	4.5	2 B 48 TB	A-1	1610	1%	0	1	0	5.5
1 B 50 TB	4.6	5.0	5.35	A-1	1610	1%	0	1	0	4.8	2 B 50 TB	A-1	1610	1%	0	1	0	6.0
1 B 52 TB	4.8	5.2	5.55	A-1	1610	1%	0	1	0	5.0	2 B 52 TB	A-1	1610	1%	0	1	0	6.5
1 B 54 TB	5.0	5.4	5.75	A-1	1610	1%	0	1	0	5.5	2 B 54 TB	A-1	1610	1%	0	1	0	7.0
1 B 56 TB	5.2	5.6	5.95	A-1	1610	1%	0	1	0	6.0	2 B 56 TB	A-1	1610	1%	0	1	0	8.2
1 B 58 TB	5.4	5.8	6.15	A-1	1610	1%	0	1	0	6.3	2 B 58 TB	A-1	1610	1%	0	1	0	8.6
1 B 60 TB	5.6	6.0	6.35	A-1	1610	1%	0	1	0	6.7	2 B 60 TB	A-1	1610	1%	0	1	0	8.8
1 B 62 TB	5.8	6.2	6.55	A-1	1610	1%	0	1	0	7.0	2 B 62 TB	A-1	1610	1%	0	1	0	9.0
1 B 64 TB	6.0	6.4	6.75	A-1	1610	1%	0	1	0	8.0	2 B 64 TB	A-1	1610	1%	0	1	0	10.0
1 B 66 TB	6.2	6.6	6.95	A-1	1610	1%	0	1	0	8.5	2 B 66 TB	A-1	1610	1%	0	1	0	10.5
1 B 68 TB	6.4	6.8	7.15	A-1	1610	1%	0	1	0	9.0	2 B 68 TB	A-1	1610	1%	0	1	0	11.0
1 B 70 TB	7.0	7.4	7.35	B-1	2517	2%	0	1%	0	8.5	2 B 74 TB	A-1	2517	2%	0	1%	0	16.0
1 B 74 TB	7.0	7.4	7.75	B-1	2517	2%	0	1%	0	9.4	2 B 86 TB	A-2	2517	2%	0	1%	0	18.0
1 B 86 TB	8.2	8.6	8.95	B-2	2517	2%	0	1%	0	12.0	2 B 94 TB	A-2	2517	2%	0	1%	0	20.0
1 B 94 TB	9.0	9.4	9.75	B-2	2517	2%	0	1%	0	14.0	2 B 110 TB	A-2	2517	2%	0	1%	0	25.0
1 B 110 TB	10.6	11.0	11.35	B-2	2517	2%	0	1%	0	15.6	2 B 124 TB	A-3	2517	2%	0	1%	0	27.0
1 B 124 TB	12.0	12.4	12.75	C-3	2517	2%	0	1%	0	16.2	2 B 136 TB	C-3	2517	2%	0	1%	0	24.0
1 B 136 TB	13.6	14.0	13.95	C-3	2517	2%	0	1%	0	17.2	2 B 154 TB	A-3	2517	2%	0	1%	0	31.0
1 B 154 TB	15.0	15.4	15.75	C-3	2517	2%	0	1%	0	18.0	2 B 160 TB	C-3	2517	2%	0	1%	0	26.0
1 B 160 TB	16.0	16.4	16.35	C-3	2517	2%	0	1%	0	24.1	2 B 184 TB	A-3	2517	2%	0	1%	0	33.0
1 B 184 TB	18.0	18.4	18.75	C-3	2517	2%	0	1%	0	31.2	2 B 200 TB	C-3	3020	3	0	2	0	49.0
											2 B 250 TB	C-3	3020	3	0	2	0	65.0
											2 B 300 TB	C-3	3020	3	0	2	0	75.0
											2 B 380 TB	C-3	3020	3	0	2	0	112.0

Dimensions in inches, weight in pounds. Weights do not include bushings. See page B-8 thru B-10 for additional bushing dimensions.

* F = 1" 1 B 154 TB

F = 1 1/4" for 1 B 184 TB

PLEASE NOTE: Dashes are REQUIRED in place of spaces when ordering or searching on PTplace.com.

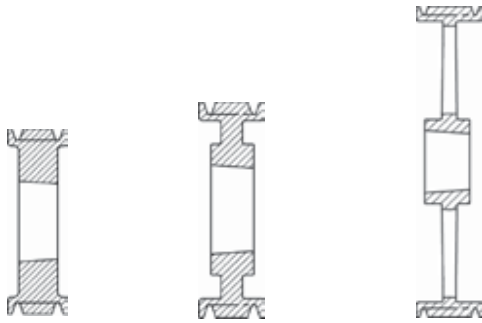

1 = SOLID

2 = WEB

3 = ARM/SPOKE

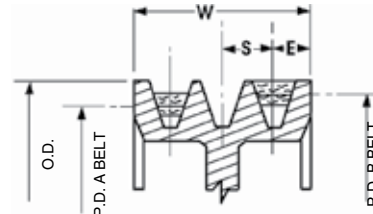

$$W = S(N-1) + 2E$$

N = No. of Grooves

Drawing shows position of "A" and "B" belts in groove.

Combination Groove Dimensions

Belt Section	E	S	OD
"AB"	1/2	3/4	P.D. "B" +.35

Taper Bushed Sheaves — A-B

Nomenclature Example: **3-B-34-TB**

3 Groove F = 2 1/2										4 Groove F = 3 1/4								
Part Number	Diameters		OD	Type	Bush	Bush Max. Bore	E	L Thru Bore	M	Wt. Less Bush	Part Number	Type	Bush	Bush Max. Bore	E	L Thru Bore	M	Wt. Less Bush
	A Belts	B Belts																
3 B 34 TB	3.0	3.4	3.75	A-1	1210	1 1/4	1 1/2	1	0	3.0	4 B 34 TB	A-1	1210	1 1/4	2 1/4	1	0	3.0
3 B 36 TB	3.2	3.6	3.95	A-1	1210	1 1/4	1 1/2	1	0	3.5	4 B 36 TB	A-1	1210	1 1/4	2 1/4	1	0	3.5
3 B 38 TB	3.4	3.8	4.15	A-1	1610	1 1/4	1 1/2	1	0	4.0	4 B 38 TB	A-1	1610	1 1/4	2 1/4	1	0	4.0
3 B 40 TB	3.6	4.0	4.35	A-1	1610	1 1/4	1 1/2	1	0	5.0	4 B 40 TB	A-1	1610	1 1/4	2 1/4	1	0	5.0
3 B 42 TB	3.8	4.2	4.55	A-1	1610	1 1/4	1 1/2	1	0	6.0	4 B 42 TB	A-1	1610	1 1/4	2 1/4	1	0	5.5
3 B 44 TB	4.0	4.4	4.75	A-1	1610	1 1/4	1 1/2	1	0	6.5	4 B 44 TB	A-1	1610	1 1/4	2 1/4	1	0	6.0
3 B 46 TB	4.2	4.6	4.95	A-1	1610	1 1/4	1 1/2	1	0	7.0	4 B 46 TB	A-1	1610	1 1/4	2 1/4	1	0	7.0
3 B 48 TB	4.4	4.8	5.15	A-1	1610	1 1/4	1 1/2	1	0	8.0	4 B 48 TB	A-1	1610	1 1/4	2 1/4	1	0	8.0
3 B 50 TB	4.6	5.0	5.35	A-1	1610	1 1/4	1 1/2	1	0	8.5	4 B 50 TB	A-1	2517	2 1/2	1 1/2	1 1/4	0	8.5
3 B 52 TB	4.8	5.2	5.55	A-1	1610	1 1/4	1 1/2	1	0	9.0	4 B 52 TB	A-1	2517	2 1/2	1 1/2	1 1/4	0	9.0
3 B 54 TB	5.0	5.4	5.75	A-1	2517	2 1/2	1 1/2	1 1/4	0	9.5	4 B 54 TB	A-1	2517	2 1/2	1 1/2	1 1/4	0	9.5
3 B 56 TB	5.2	5.6	5.95	A-1	2517	2 1/2	1 1/2	1 1/4	0	10.0	4 B 56 TB	A-1	2517	2 1/2	1 1/2	1 1/4	0	10.0
3 B 58 TB	5.4	5.8	6.15	A-1	2517	2 1/2	1 1/2	1 1/4	0	10.5	4 B 58 TB	A-1	2517	2 1/2	1 1/2	1 1/4	0	12.0
3 B 60 TB	5.6	6.0	6.35	A-1	2517	2 1/2	1 1/2	1 1/4	0	11.0	4 B 60 TB	A-1	2517	2 1/2	1 1/2	1 1/4	0	12.5
3 B 62 TB	5.8	6.2	6.55	A-1	2517	2 1/2	1 1/2	1 1/4	0	11.5	4 B 62 TB	A-1	2517	2 1/2	1 1/2	1 1/4	0	13.0
3 B 64 TB	6.0	6.4	6.75	A-1	2517	2 1/2	1 1/2	1 1/4	0	12.0	4 B 64 TB	A-1	2517	2 1/2	1 1/2	1 1/4	0	14.0
3 B 66 TB	6.2	6.6	6.95	A-1	2517	2 1/2	1 1/2	1 1/4	0	12.3	4 B 66 TB	A-1	2517	2 1/2	1 1/2	1 1/4	0	15.0
3 B 68 TB	6.4	6.8	7.15	A-1	2517	2 1/2	1 1/2	1 1/4	0	12.8	4 B 68 TB	A-1	2517	2 1/2	1 1/2	1 1/4	0	16.0
3 B 74 TB	7.0	7.4	7.75	A-1	2517	2 1/2	1 1/2	1 1/4	0	16.0	4 B 74 TB	A-1	2517	2 1/2	1 1/2	1 1/4	0	16.0
3 B 80 TB	8.0	8.4	8.35	A-1	2517	2 1/2	0	1 1/4	3/4	19.0	4 B 70 TB	A-1	2517	2 1/2	0	1 1/4	1 1/2	20.0
3 B 86 TB	8.2	8.6	8.95	A-2	2517	2 1/2	1 1/2	1 1/4	0	19.0	4 B 80 TB	A-1	2517	2 1/2	0	1 1/4	1 1/2	21.0
3 B 94 TB	9.0	9.4	9.75	A-2	2517	2 1/2	1 1/2	1 1/4	0	21.0	4 B 86 TB	A-2	2517	2 1/2	1 1/2	1 1/4	0	21.0
3 B 110 TB	10.6	11.0	11.35	A-2	2517	2 1/2	1 1/2	1 1/4	0	24.0	4 B 94 TB	A-2	2517	2 1/2	1 1/2	1 1/4	0	23.0
3 B 124 TB	12.0	12.4	12.75	A-3	2517	2 1/2	0	1 1/4	3/4	28.0	4 B 110 TB	A-2	2517	2 1/2	1 1/2	1 1/4	0	28.0
3 B 136 TB	13.6	14.0	13.95	A-3	2517	2 1/2	0	1 1/4	3/4	25.0	4 B 124 TB	A-3	2517	2 1/2	1 1/2	1 1/4	1 1/4	32.8
3 B 154 TB	15.0	15.4	15.75	A-3	2517	2 1/2	0	1 1/4	3/4	30.0	4 B 136 TB	A-3	2517	2 1/2	1 1/2	1 1/4	1 1/4	34.0
3 B 160 TB	16.0	16.4	16.35	A-3	2517	2 1/2	0	1 1/4	3/4	32.0	4 B 154 TB	A-3	2517	2 1/2	1 1/2	1 1/4	1 1/4	42.0
3 B 184 TB	18.0	18.4	18.75	A-3	2517	2 1/2	0	1 1/4	3/4	44.0	4 B 160 TB	A-3	2517	2 1/2	1 1/2	1 1/4	1 1/4	45.1
3 B 200 TB	19.6	20.0	20.35	A-3	3020	3	0	2	1/2	58.0	4 B 184 TB	A-3	2517	2 1/2	1 1/2	1 1/4	1	53.0
3 B 250 TB	24.6	25.0	25.35	A-3	3020	3	0	2	1/2	74.0	4 B 200 TB	A-3	3020	3	1/2	2	3/4	63.0
3 B 300 TB	29.6	30.0	30.35	A-3	3020	3	0	2	1/2	84.0	4 B 250 TB	A-3	3030	3	0	3	1 1/4	80.0
3 B 380 TB	37.6	38.0	38.35	B-3	3020	3	0	3	1/2	135.0	4 B 300 TB	A-3	3030	3	0	3	1 1/4	100.0
											4 B 380 TB	A-3	3030	3	0	3	1 1/4	142.0

Dimensions in inches, weight in pounds. Weights do not include bushings. See page B-8 thru B-10 for additional bushing dimensions.

PLEASE NOTE: Dashes are REQUIRED in place of spaces when ordering or searching on PTplace.com.

Taper Bushed Sheaves — A-B

Nomenclature Example: **5-B-34-TB**

5 Groove F = 4											6 Groove F = 4 ^{3/4}							
Part Number	Diameters		OD	Type	Bush	Bush Max. Bore	E	L Thru Bore	M	Wt. Less Bush	Part Number	Type	Bush	Bush Max. Bore	E	L Thru Bore	M	Wt. Less Bush
	A Belts	B Belts																
5 B 34 TB	3.0	3.4	3.75	A-1	1210	1 ^{1/4}	2 ^{1/2}	1 ^{1/2}	0	5.0								
5 B 36 TB	3.2	3.6	3.95	A-1	1210	1 ^{1/4}	2 ^{1/2}	1 ^{1/2}	0	5.5								
5 B 38 TB	3.4	3.8	4.15	A-1	1215	1 ^{1/4}	2 ^{1/2}	1 ^{1/2}	1 ^{1/8}	6.0								
5 B 40 TB	3.6	4.0	4.35	A-1	1215	1 ^{1/4}	2 ^{1/2}	1 ^{1/2}	1 ^{1/8}	6.5								
5 B 42 TB	3.8	4.2	4.55	A-1	1615	1 ^{1/4}	2 ^{1/2}	1 ^{1/2}	0	7.0	6 B 42 TB	A-1	1615	1 ^{1/4}	3 ^{1/4}	1 ^{1/2}	0	8.0
5 B 44 TB	4.0	4.4	4.75	A-1	1615	1 ^{1/4}	2 ^{1/2}	1 ^{1/2}	0	8.0	6 B 44 TB	A-1	1615	1 ^{1/4}	3 ^{1/4}	1 ^{1/2}	0	9.0
5 B 46 TB	4.2	4.6	4.95	A-1	1615	1 ^{1/4}	2 ^{1/2}	1 ^{1/2}	0	9.0	6 B 46 TB	A-1	1615	1 ^{1/4}	3 ^{1/4}	1 ^{1/2}	0	10.0
5 B 48 TB	4.8	5.2	5.15	A-1	1615	1 ^{1/4}	2 ^{1/2}	1 ^{1/2}	1 ^{1/8}	9.4	6 B 48 TB	A-1	1615	1 ^{1/4}	3 ^{1/4}	1 ^{1/2}	2	11.0
5 B 50 TB	4.6	5.0	5.35	A-1	1615	1 ^{1/4}	2 ^{1/2}	1 ^{1/2}	0	10.5	6 B 50 TB	A-1	1615	1 ^{1/4}	3 ^{1/4}	1 ^{1/2}	2	11.9
5 B 52 TB	4.8	5.2	5.55	A-1	1615	1 ^{1/4}	2 ^{1/2}	1 ^{1/2}	0	11.3	6 B 52 TB	A-1	1615	1 ^{1/4}	3 ^{1/4}	1 ^{1/2}	2	12.8
5 B 54 TB	5.0	5.4	5.75	A-1	2517	2 ^{1/2}	2 ^{1/2}	1 ^{1/2}	0	11.5	6 B 54 TB	A-1	2517	2 ^{1/2}	3 ^{1/4}	1 ^{1/2}	2	13.7
5 B 56 TB	5.2	5.6	5.95	A-1	2517	2 ^{1/2}	2 ^{1/2}	1 ^{1/2}	0	12.0	6 B 56 TB	A-1	2517	2 ^{1/2}	3 ^{1/4}	1 ^{1/2}	2	14.6
5 B 58 TB	5.8	6.2	6.15	A-1	2517	2 ^{1/2}	2 ^{1/2}	1 ^{1/2}	1 ^{1/8}	13.0	6 B 58 TB	A-1	2517	2 ^{1/2}	3 ^{1/4}	1 ^{1/2}	1 ^{1/8}	14.0
5 B 60 TB	5.6	6.0	6.35	A-1	2517	2 ^{1/2}	2 ^{1/2}	1 ^{1/2}	0	14.0	6 B 60 TB	A-1	2517	2 ^{1/2}	3 ^{1/4}	1 ^{1/2}	0	16.0
5 B 62 TB	6.2	6.6	6.55	A-1	2517	2 ^{1/2}	2 ^{1/2}	1 ^{1/2}	1 ^{1/8}	14.0	6 B 62 TB	A-1	2517	2 ^{1/2}	3 ^{1/4}	1 ^{1/2}	1 ^{1/8}	16.0
5 B 64 TB	6.0	6.4	6.75	A-1	2517	2 ^{1/2}	2 ^{1/2}	1 ^{1/2}	0	16.0	6 B 64 TB	A-1	2517	2 ^{1/2}	3 ^{1/4}	1 ^{1/2}	0	19.5
5 B 66 TB	6.6	7.0	6.95	A-1	2517	2 ^{1/2}	2 ^{1/2}	1 ^{1/2}	1 ^{1/8}	16.0	6 B 66 TB	A-1	2517	2 ^{1/2}	3 ^{1/4}	1 ^{1/2}	1 ^{1/8}	20.0
5 B 68 TB	6.4	6.8	7.15	A-1	2517	2 ^{1/2}	2 ^{1/2}	1 ^{1/2}	0	18.0	6 B 68 TB	A-1	2517	2 ^{1/2}	3 ^{1/4}	1 ^{1/2}	0	21.0
5 B 70 TB	7.0	7.4	7.35	A-1	2517	2 ^{1/2}	2 ^{1/2}	1 ^{1/2}	1 ^{1/2}	18.0	6 B 70 TB	A-1	2517	2 ^{1/2}	3 ^{1/4}	1 ^{1/2}	1 ^{1/2}	21.0
5 B 74 TB	7.0	7.4	7.75	A-1	2517	2 ^{1/2}	2 ^{1/2}	1 ^{1/2}	0	22.0	6 B 74 TB	A-1	2517	2 ^{1/2}	3 ^{1/4}	1 ^{1/2}	0	25.0
5 B 80 TB	8.0	8.4	8.35	A-1	2517	2 ^{1/2}	2 ^{1/2}	1 ^{1/2}	1 ^{1/2}	23.0	6 B 80 TB	A-1	2517	2 ^{1/2}	3 ^{1/4}	1 ^{1/2}	1 ^{1/2}	26.0
5 B 86 TB	8.2	8.6	8.95	A-2	2517	2 ^{1/2}	2 ^{1/2}	1 ^{1/2}	0	24.0	6 B 86 TB	A-2	2517	2 ^{1/2}	3 ^{1/4}	1 ^{1/2}	0	27.0
5 B 94 TB	9.0	9.4	9.75	A-2	2517	2 ^{1/2}	2 ^{1/2}	1 ^{1/2}	0	26.0	6 B 94 TB	A-2	2517	2 ^{1/2}	3 ^{1/4}	1 ^{1/2}	0	28.0
5 B 110 TB	10.6	11.0	11.35	A-2	2517	2 ^{1/2}	2 ^{1/2}	1 ^{1/2}	0	35.0	6 B 110 TB	A-2	2517	2 ^{1/2}	3 ^{1/4}	1 ^{1/2}	0	34.0
5 B 124 TB	12.0	12.4	12.75	A-3	2517	2 ^{1/2}	2 ^{1/2}	1 ^{1/2}	1 ^{1/2}	40.0	6 B 124 TB	A-3	2517	2 ^{1/2}	3 ^{1/4}	1 ^{1/2}	1 ^{1/2}	43.0
5 B 136 TB	13.6	14.0	13.95	A-3	2517	2 ^{1/2}	2 ^{1/2}	1 ^{1/2}	1 ^{1/2}	38.0	6 B 136 TB	A-3	2517	2 ^{1/2}	3 ^{1/4}	1 ^{1/2}	1 ^{1/2}	42.0
5 B 154 TB	15.0	15.4	15.75	A-3	2517	2 ^{1/2}	2 ^{1/2}	1 ^{1/2}	1 ^{1/2}	47.0	6 B 154 TB	A-3	2517	2 ^{1/2}	3 ^{1/4}	1 ^{1/2}	1 ^{1/2}	52.0
5 B 160 TB	16.0	16.4	16.35	A-3	2517	2 ^{1/2}	2 ^{1/2}	1 ^{1/2}	1 ^{1/2}	67.0	6 B 160 TB	A-3	2517	2 ^{1/2}	3 ^{1/4}	1 ^{1/2}	1 ^{1/2}	63.0
5 B 184 TB	18.0	18.4	18.75	A-3	2517	2 ^{1/2}	2 ^{1/2}	1 ^{1/2}	1 ^{1/2}	52.0	6 B 184 TB	A-3	2517	2 ^{1/2}	3 ^{1/4}	1 ^{1/2}	1 ^{1/2}	52.0
5 B 200 TB	19.6	20.0	20.35	A-3	3030	3	3	3	3	75.0	6 B 200 TB	A-3	3030	3	3	3	3	85.0
5 B 250 TB	24.6	25.0	25.35	A-3	3030	3	3	3	3	81.0	6 B 250 TB	A-3	3030	3	3	3	3	100.0
5 B 300 TB	29.6	30.0	30.35	A-3	3030	3	3	3	3	109.0	6 B 300 TB	A-3	3030	3	3	3	3	137.0
5 B 380 TB	37.6	38.0	38.35	A-3	3030	3	3	3	3	158.0	6 B 380 TB	A-3	3030	3	3	3	3	168.0

8 Groove F = 6 ^{1/4}											10 Groove F = 7 ^{3/4}							
Part Number	Diameters		OD	Type	Bush	Bush Max. Bore	E	L Thru Bore	M	Wt. Less Bush	Part Number	Type	Bush	Bush Max. Bore	E	L Thru Bore	M	Wt. Less Bush
	A Belts	B Belts																
8 B 54 TB	5.0	5.4	5.75	A-1	2517	2 ^{1/2}	1 ^{1/2}	1 ^{1/2}	2 ^{1/2}	16.0	10 B 54 TB	A-1	2517	2 ^{1/2}	3	1 ^{1/2}	3	18.0
8 B 56 TB	5.2	5.6	5.95	A-1	2517	2 ^{1/2}	1 ^{1/2}	1 ^{1/2}	2 ^{1/2}	17.0	10 B 56 TB	A-1	2517	2 ^{1/2}	3	1 ^{1/2}	3	20.0
8 B 60 TB	5.6	6.0	6.35	A-1	2517	2 ^{1/2}	1 ^{1/2}	1 ^{1/2}	2 ^{1/2}	19.0	10 B 60 TB	A-1	2517	2 ^{1/2}	3	1 ^{1/2}	3	22.0
8 B 64 TB	6.0	6.4	6.75	A-1	2517	2 ^{1/2}	1 ^{1/2}	1 ^{1/2}	2 ^{1/2}	21.0	10 B 64 TB	A-1	2517	2 ^{1/2}	3	1 ^{1/2}	3	25.5
8 B 68 TB	6.4	6.8	7.15	A-1	2517	2 ^{1/2}	1 ^{1/2}	1 ^{1/2}	2 ^{1/2}	25.0	10 B 68 TB	A-1	2517	2 ^{1/2}	3	1 ^{1/2}	3	28.0
8 B 74 TB	7.0	7.4	7.75	A-1	2517	2 ^{1/2}	1 ^{1/2}	1 ^{1/2}	2 ^{1/2}	29.0	10 B 74 TB	A-1	2517	2 ^{1/2}	3	1 ^{1/2}	3	35.0
8 B 86 TB	8.2	8.6	8.95	A-1	3030	3	3	3	2 ^{1/2}	37.0	10 B 86 TB	A-1	3030	3	3	3	2 ^{1/2}	43.0
8 B 94 TB	9.0	9.4	9.95	A-2	3030	3	3	3	2 ^{1/2}	41.0	10 B 94 TB	A-2	3030	3	3	3	2 ^{1/2}	46.0
8 B 110 TB	10.6	11.0	11.35	A-2	3030	3	3	3	2 ^{1/2}	51.0	10 B 110 TB	A-2	3030	3	3	3	2 ^{1/2}	52.0
8 B 124 TB	12.0	12.4	12.75	A-3	3030	3	3	3	2 ^{1/2}	56.0								
8 B 154 TB	15.0	15.4	15.75	A-3	3030	3	3	3	2 ^{1/2}	69.0								
8 B 184 TB	18.0	18.4	18.75	A-3	3030	3	3	3	2 ^{1/2}	99.0								
8 B 200 TB	19.6	20.0	20.35	A-3	3030	3	3	3	2 ^{1/2}	115.0								
8 B 250 TB	24.6	25.0	25.35	A-3	3535	3 ^{1/2}	3 ^{1/2}	3 ^{1/2}	2	145.0								
8 B 300 TB	29.6	30.0	30.35	A-3	3535	3 ^{1/2}	3 ^{1/2}	3 ^{1/2}	2	170.0								
8 B 380 TB	37.6	38.0	38.35	A-3	4040	4	4	4	1 ^{1/2}	260.0								

Dimensions in inches, weight in pounds. Weights do not include bushings. See page B-8 thru B-10 for additional bushing dimensions.

PLEASE NOTE: Dashes are REQUIRED in place of spaces when ordering or searching on PTplace.com.

V-Belt | Taper Bushed Sheaves

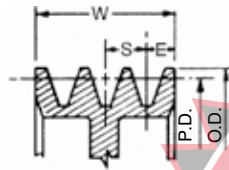
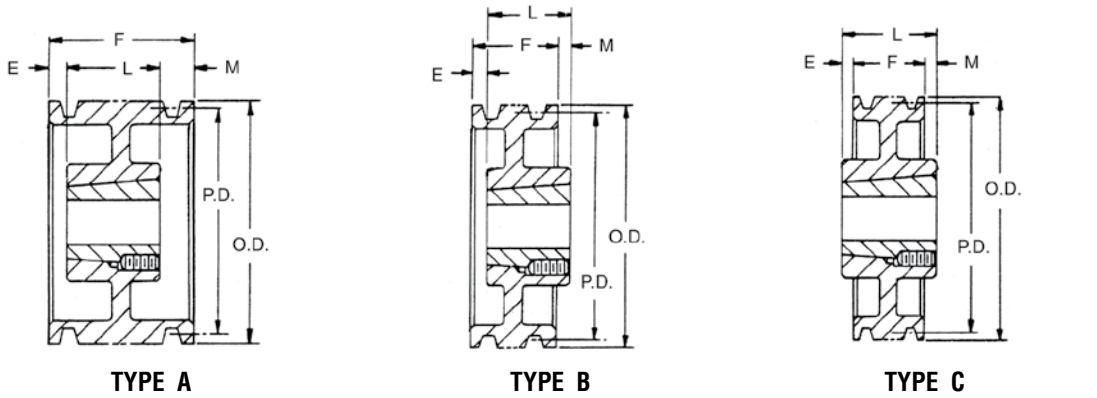

Groove Dimensions

Belt Section	E	S	O.D.
"C"	1 1/16	1	P.D. + .40

$W = S(N-1) + 2E$
 N = No. of Grooves

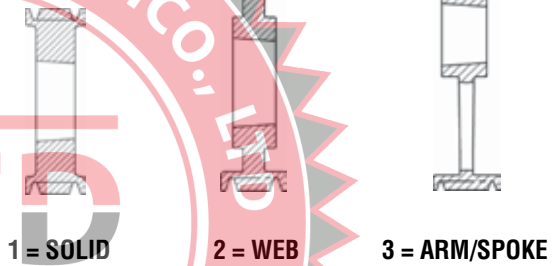

Taper Bushed Sheaves — C

Nomenclature Example: **2-C-70-TB**

2 Groove F = 2%										3 Groove F = 3%							
Part Number	PD	OD	Type	Bush	Bush Max. Bore	E	L Thru Bore	M	Wt. Less Bush	Part Number	Type	Bush	Bush Max. Bore	E	L Thru Bore	M	Wt. Less Bush
	C Belt																
2 C 70 TB	7.00	7.40	A-1	2517	2 1/2	%	1 1/4	0	15.0	3 C 70 TB	A-1	2517	2 1/2	1/4	1 1/4	1 1/4	18.0
2 C 75 TB	7.50	7.90	A-1	2517	2 1/2	%	1 1/4	0	17.0	3 C 75 TB	A-1	2517	2 1/2	1/4	1 1/4	1 1/4	20.0
2 C 80 TB	8.00	8.40	A-1	2517	2 1/2	%	1 1/4	0	20.0	3 C 80 TB	A-1	2517	2 1/2	1/4	1 1/4	1 1/4	22.0
2 C 85 TB	8.50	8.90	A-2	2517	2 1/2	%	1 1/4	0	22.0	3 C 85 TB	A-2	2517	2 1/2	1/4	1 1/4	1 1/4	23.0
2 C 90 TB	9.00	9.40	A-2	2517	2 1/2	%	1 1/4	0	23.0	3 C 90 TB	A-2	2517	2 1/2	1/4	1 1/4	1 1/4	24.0
2 C 95 TB	9.50	9.90	A-2	2517	2 1/2	%	1 1/4	0	24.0	3 C 95 TB	A-2	2517	2 1/2	1/4	1 1/4	1 1/4	27.0
2 C 100 TB	10.00	10.40	A-2	2517	2 1/2	%	1 1/4	0	25.0	3 C 100 TB	A-2	2517	2 1/2	1/4	1 1/4	1 1/4	29.0
2 C 105 TB	10.50	10.90	A-2	2517	2 1/2	%	1 1/4	0	26.0	3 C 105 TB	A-2	2517	2 1/2	1/4	1 1/4	1 1/4	32.0
2 C 110 TB	11.00	11.40	A-2	2517	2 1/2	%	1 1/4	0	27.0	3 C 110 TB	A-2	2517	2 1/2	1/4	1 1/4	1 1/4	35.0
2 C 120 TB	12.00	12.40	A-2	2517	2 1/2	%	1 1/4	0	33.0	3 C 120 TB	A-2	3020	3	0	2	1 1/4	44.0
2 C 130 TB	13.00	13.40	A-3	2517	2 1/2	%	1 1/4	0	35.0	3 C 130 TB	A-3	3020	3	0	2	1 1/4	49.0
2 C 140 TB	14.00	14.40	A-3	2517	2 1/2	%	1 1/4	0	36.0	3 C 140 TB	A-3	3020	3	0	2	1 1/4	50.0
2 C 160 TB	16.00	16.40	A-3	2517	2 1/2	%	1 1/4	0	42.0	3 C 160 TB	A-3	3020	3	0	2	1 1/4	64.0
2 C 180 TB	18.00	18.40	A-3	3020	3	0	2	%	42.0	3 C 180 TB	A-3	3030	3	0	3	%	64.0
2 C 200 TB	20.00	20.40	A-3	3020	3	0	2	%	45.0	3 C 200 TB	A-3	3030	3	0	3	%	78.0
2 C 240 TB	24.00	24.40	A-3	3020	3	0	2	%	72.0	3 C 240 TB	A-3	3030	3	0	3	%	96.0
2 C 300 TB	30.00	30.40	C-3	3535	3 1/2	1/2	3 1/2	%	85.0	3 C 300 TB	B-3	3535	3 1/2	0	3 1/2	1/2	125.0
	36.00	36.40								3 C 360 TB	B-3	3535	3 1/2	0	3 1/2	1/2	175.0

Dimensions in inches, weight in pounds. Weights do not include bushings. See page B-8 thru B-10 for additional bushing dimensions.

PLEASE NOTE: Dashes are REQUIRED in place of spaces when ordering or searching on PTplace.com.

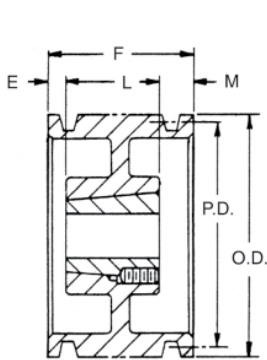

TYPE A

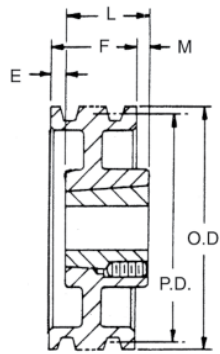

TYPE B

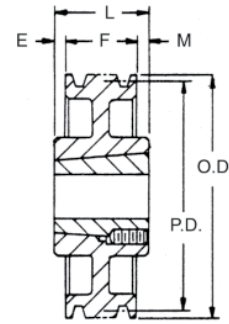

TYPE C

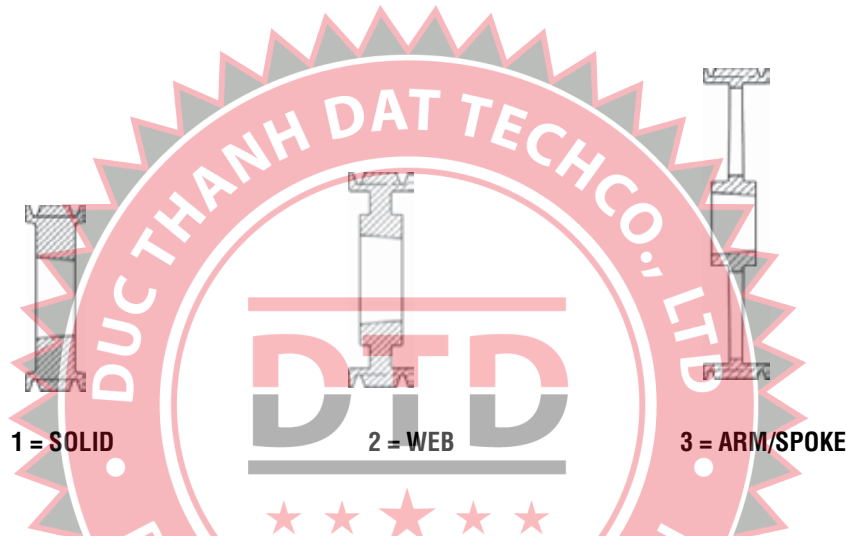

V-Belt | Taper Bushed Sheaves

Taper Bushed Sheaves — C

Nomenclature Example: **4-C-70-TB**

4 Groove F = 4%										5 Groove F = 5%							
Part Number	PD C Belt	OD	Type	Bush	Bush Max. Bore	E	L Thru Bore	M	Wt. Less Bush	Part Number	Type	Bush	Bush Max. Bore	E	L Thru Bore	M	Wt. Less Bush
4 C 70 TB	7.00	7.40	A-1	2517	2½	½	1%	2%	20.0	5 C 70 TB	A-1	2517	2½	1½	1%	2%	23.0
4 C 75 TB	7.50	7.90	A-1	2517	2½	½	1%	2%	23.0	5 C 75 TB	A-1	2517	2½	1½	1%	2%	26.0
4 C 80 TB	8.00	8.40	A-1	2517	2½	½	1%	2%	25.0	5 C 80 TB	A-1	2517	2½	1½	1%	2%	30.0
4 C 85 TB	8.50	8.90	A-2	2517	2½	½	1%	2%	26.0	5 C 85 TB	A-1	2517	2½	1½	1%	2%	34.0
4 C 90 TB	9.00	9.40	A-2	2517	2½	½	1%	2%	27.0	5 C 90 TB	A-2	2517	2½	1½	1%	2%	35.0
4 C 95 TB	9.50	9.90	A-2	2517	2½	½	1%	2%	36.0	5 C 95 TB	A-2	2517	2½	1½	1%	2%	36.0
4 C 100 TB	10.00	10.40	A-2	2517	2½	½	1%	2%	39.0	5 C 100 TB	A-2	2517	2½	1½	1%	2%	39.0
4 C 105 TB	10.50	10.90	A-2	2517	2½	½	1%	2%	42.0	5 C 105 TB	A-2	2517	2½	1½	1%	2%	42.0
4 C 110 TB	11.00	11.40	A-2	2517	2½	½	1%	2%	45.0	5 C 110 TB	A-2	2517	2½	1½	1%	2%	43.0
4 C 120 TB	12.00	12.40	A-2	3030	3	0	3	1%	47.0	5 C 120 TB	A-2	3030	3	½	3	1%	58.0
4 C 130 TB	13.00	13.40	A-3	3030	3	0	3	1%	51.0	5 C 130 TB	A-3	3030	3	½	3	1%	63.0
4 C 140 TB	14.00	14.40	A-3	3030	3	0	3	1%	54.0	5 C 140 TB	A-3	3030	3	½	3	1%	65.0
4 C 160 TB	16.00	16.40	A-3	3030	3	0	3	1%	71.0	5 C 160 TB	A-3	3030	3	½	3	1%	70.0
4 C 180 TB	18.00	18.40	A-3	3030	3	0	3	1%	81.0	5 C 180 TB	A-3	3030	3	½	3	1%	83.0
4 C 200 TB	20.00	20.40	A-3	3030	3	0	3	1%	84.0	5 C 200 TB	A-3	3535	3½	0	3½	1%	110.0
4 C 240 TB	24.00	24.40	A-3	3030	3	0	3	1%	116.0	5 C 240 TB	A-3	3535	3½	0	3½	1%	138.0
4 C 300 TB	30.00	30.40	A-3	3535	3½	0	3½	¾	164.0	5 C 300 TB	A-3	3535	3½	0	3½	1%	176.0
4 C 360 TB	36.00	36.40	A-3	3535	3½	0	3½	¾	192.0	5 C 360 TB	A-3	4040	4	¼	4	1%	244.0
4 C 440 TB	44.00	44.40	A-3	4040	4	0	4	¾	282.0	5 C 440 TB	A-3	4040	4	¼	4	1%	288.0

PLEASE NOTE: Dashes are REQUIRED in place of spaces when ordering or searching on PTplace.com.

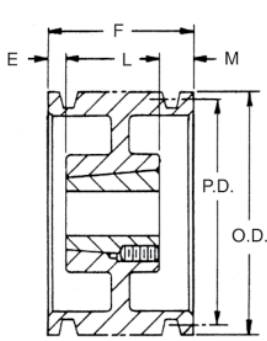

TYPE A

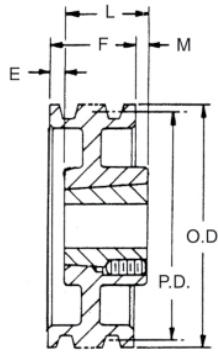

TYPE B

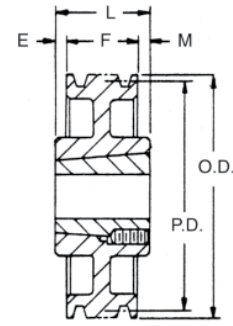

TYPE C

Taper Bushed Sheaves — C

Nomenclature Example: **6-C-70-TB**

6 Groove F = 6%										8 Groove F = 8%							
Part Number	PD C Belt	OD	Type	Bush	Bush Max. Bore	E	L Thru Bore	M	Wt. Less Bush	Part Number	Type	Bush	Bush Max. Bore	E	L Thru Bore	M	Wt. Less Bush
6 C 75 TB	7.50	7.90	A-1	3030	3	1	3	2%	31.0	8 C 85 TB	A-1	3030	3	2	3	3%	47.0
6 C 80 TB	8.00	8.40	A-1	3030	3	1	3	2%	35.0	8 C 90 TB	A-1	3535	3	1 1/2	3 1/2	3%	64.0
6 C 85 TB	8.50	8.90	A-1	3030	3	1	3	2%	40.0	8 C 95 TB	A-1	3535	3 1/2	1 1/2	3 1/2	3%	67.0
6 C 90 TB	9.00	9.40	A-1	3030	3	1	3	2%	47.0	8 C 100 TB	A-1	3535	3 1/2	1 1/2	3 1/2	3%	70.0
6 C 95 TB	9.50	9.90	A-1	3030	3	1	3	2%	53.0	8 C 105 TB	A-1	3535	3 1/2	1 1/2	3 1/2	3%	84.0
6 C 100 TB	10.00	10.40	A-1	3030	3	1	3	2%	57.0	8 C 110 TB	A-1	3535	3 1/2	1 1/2	3 1/2	3%	87.0
6 C 105 TB	10.50	10.90	A-2	3030	3	1	3	2%	58.0	8 C 120 TB	A-2	3535	3 1/2	1 1/2	3 1/2	3%	90.0
6 C 110 TB	11.00	11.40	A-2	3030	3	1	3	2%	66.0	8 C 130 TB	A-2	3535	3 1/2	1 1/2	3 1/2	3%	97.0
6 C 120 TB	12.00	12.40	A-2	3030	3	1	3	2%	70.0	8 C 140 TB	A-2	3535	3 1/2	1 1/2	3 1/2	3%	105.0
6 C 130 TB	13.00	13.40	A-3	3030	3	1	3	2%	75.0	8 C 160 TB	A-3	3535	3 1/2	1 1/2	3 1/2	3%	115.0
6 C 140 TB	14.00	14.40	A-3	3535	3 1/2	1 1/2	3 1/2	2%	80.0	8 C 180 TB	A-3	4040	4	1 1/2	4	2%	137.0
6 C 160 TB	16.00	16.40	A-3	3535	3 1/2	1 1/2	3 1/2	2%	87.0	8 C 200 TB	A-3	4040	4	1 1/2	4	2%	180.0
6 C 180 TB	18.00	18.40	A-3	3535	3 1/2	1 1/2	3 1/2	2%	102.0	8 C 240 TB	A-3	4040	4	1 1/2	4	2%	205.0
6 C 200 TB	20.00	20.40	A-3	3535	3 1/2	1 1/2	3 1/2	2%	126.0	8 C 300 TB	A-3	4040	4	1 1/2	4	2%	263.0
6 C 240 TB	24.00	24.40	A-3	3535	3 1/2	1 1/2	3 1/2	2%	150.0	8 C 360 TB	A-3	4545	4 1/2	1 1/2	4 1/2	2%	343.0
6 C 300 TB	30.00	30.40	A-3	4040	4	1	4	1%	226.0	8 C 440 TB	A-3	4545	4 1/2	1 1/2	4 1/2	2%	432.0
6 C 360 TB	36.00	36.40	A-3	4040	4	1	4	1%	270.0								
6 C 440 TB	44.00	44.40	A-3	4040	4	1	4	1%	320.0								

10 Groove F = 10%										12 Groove F = 12%							
Part Number	PD C Belt	OD	Type	Bush	Bush Max. Bore	E	L Thru Bore	M	Wt. Less Bush	Part Number	Type	Bush	Bush Max. Bore	E	L Thru Bore	M	Wt. Less Bush
10 C 95 TB	9.50	9.90	A-1	4545	4 1/2	1 1/2	4 1/2	4%	66.0	12 C 95 TB	A-1	4040	4	3 1/2	4	4%	75.0
10 C 100 TB	10.00	10.40	A-1	4545	4 1/2	1 1/2	4 1/2	4%	77.0	12 C 100 TB	A-1	4040	4	3 1/2	4	4%	85.0
10 C 105 TB	10.50	10.90	A-1	4545	4 1/2	1 1/2	4 1/2	4%	87.0	12 C 105 TB	A-1	4040	4	3 1/2	4	4%	95.0
10 C 110 TB	11.00	11.40	A-1	4545	4 1/2	1 1/2	4 1/2	4%	98.0	12 C 110 TB	A-1	4040	4	3 1/2	4	4%	104.0
10 C 120 TB	12.00	12.40	A-1	4545	4 1/2	1 1/2	4 1/2	4%	121.0	12 C 120 TB	A-1	4040	4	3 1/2	4	4%	126.0
10 C 130 TB	13.00	13.40	A-1	4545	4 1/2	2	4 1/2	3%	146.0	12 C 130 TB	A-1	4545	4 1/2	3	4 1/2	4%	156.0
10 C 140 TB	14.00	14.40	A-2	4545	4 1/2	2	4 1/2	3%	170.1	12 C 140 TB	A-1	4545	4 1/2	3	4 1/2	4%	184.0
10 C 160 TB	16.00	16.40	A-2	4545	4 1/2	2	4 1/2	3%	173.4								
10 C 180 TB	18.00	18.40	A-2	4545	4 1/2	2	4 1/2	3%	180.1								
10 C 200 TB	20.00	20.40	A-3	4545	4 1/2	2	4 1/2	3%	201.0								
10 C 240 TB	24.00	24.40	A-3	4545	4 1/2	2	4 1/2	3%	243.0								
10 C 300 TB	30.00	30.40	A-3	4545	4 1/2	2	4 1/2	3%	320.0								
10 C 360 TB	36.00	36.40	A-3	4545	4 1/2	2	4 1/2	3%	464.0								
10 C 440 TB	44.00	44.40	A-3	4545	4 1/2	2	4 1/2	3%	508.0								

Dimensions in inches, weight in pounds. Weights do not include bushings. See page B-8 thru B-10 for additional bushing dimensions.

PLEASE NOTE: Dashes are REQUIRED in place of spaces when ordering or searching on PTplace.com.

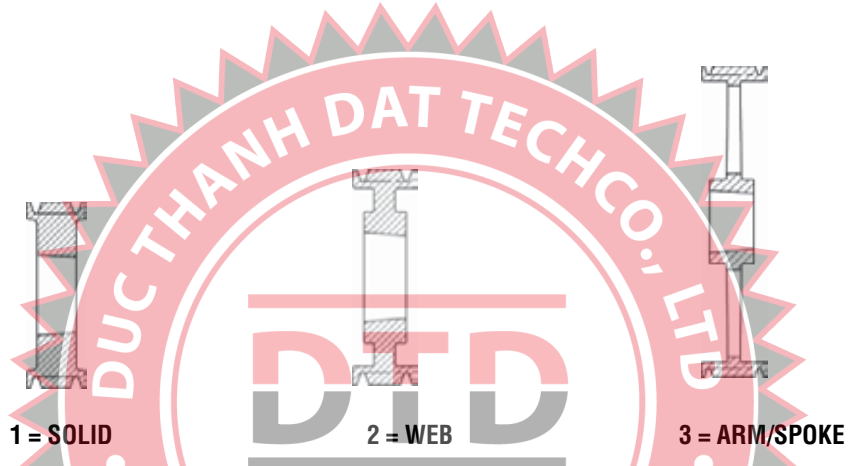
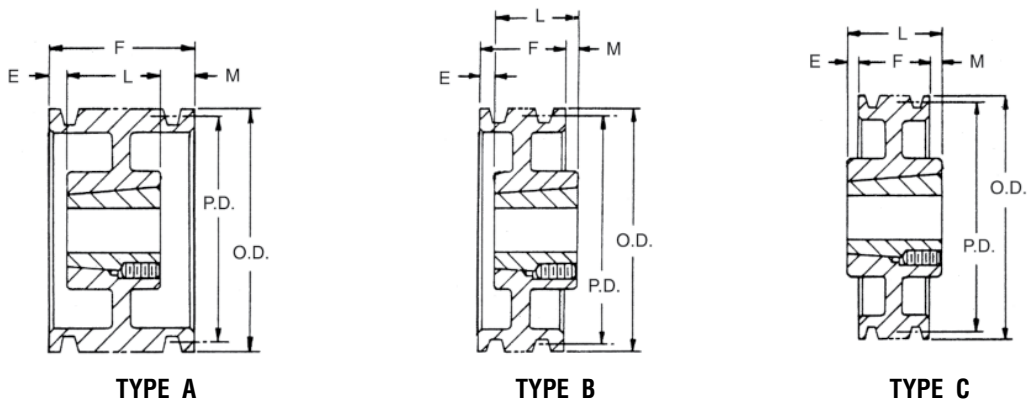

V-Belt | Taper Bushed Sheaves

Taper Bushed Sheaves — D

Nomenclature Example: 4-D-120-TB

4 Groove F = 6 1/16										5 Groove F = 7 1/2							
Part Number	PD D Belt	OD	Type	Bush	Bush Max. Bore	E	L Thru Bore	M	Wt. Less Bush	Part Number	Type	Bush	Bush Max. Bore	E	L Thru Bore	M	Wt. Less Bush
4 D 130 TB	13.0	13.6	A-2	3535	3 1/2	3/8	3 1/2	1 1/16	73.0	5 D 130 TB	A-2	4040	4	3/4	4	2 1/2	87.0
4 D 135 TB	13.5	14.1	A-2	3535	3 1/2	3/8	3 1/2	1 1/16	78.0	5 D 135 TB	A-2	4040	4	3/4	4	2 1/2	92.0
4 D 140 TB	14.0	14.6	A-2	3535	3 1/2	3/8	3 1/2	1 1/16	83.0	5 D 140 TB	A-2	4040	4	3/4	4	2 1/2	97.0
4 D 145 TB	14.5	15.1	A-2	3535	3 1/2	3/8	3 1/2	1 1/16	94.0	5 D 145 TB	A-2	4040	4	3/4	4	2 1/2	102.0
4 D 150 TB	15.0	15.6	A-2	3535	3 1/2	3/8	3 1/2	1 1/16	94.0	5 D 150 TB	A-2	4040	4	3/4	4	2 1/2	107.0
4 D 155 TB	15.5	16.1	A-2	3535	3 1/2	3/8	3 1/2	1 1/16	99.0	5 D 155 TB	A-2	4040	4	3/4	4	2 1/2	112.0
4 D 160 TB	16.0	16.6	A-2	3535	3 1/2	3/8	3 1/2	1 1/16	104.0	5 D 160 TB	A-2	4040	4	3/4	4	2 1/2	112.0
4 D 180 TB	18.0	18.6	A-3	3535	3 1/2	3/8	3 1/2	1 1/16	109.0	5 D 180 TB	A-3	4040	4	1	4	2 1/2	132.0
4 D 220 TB	22.0	22.6	A-3	4040	4	3/8	4	1 1/16	142.0	5 D 220 TB	A-3	4040	4	1	4	2 1/2	162.0
4 D 270 TB	27.0	27.6	A-3	4040	4	3/8	4	1 1/16	182.0	5 D 270 TB	A-3	4040	4	1	4	2 1/2	207.0

PLEASE NOTE: Dashes are REQUIRED in place of spaces when ordering or searching on PTplace.com.

Taper Bushed Sheaves — D

Nomenclature Example: **6-D-120-TB**

6 Groove F = 8 ¹⁵ / ₁₆										8 Groove F = 11 ¹³ / ₁₆							
Part Number	PD	OD	Type	Bush	Bush Max. Bore	E	L Thru Bore	M	Wt. Less Bush	Part Number	Type	Bush	Bush Max. Bore	E	L Thru Bore	M	Wt. Less Bush
	D Belt																
6 D 120 TB	12.0	12.6	A-1	4040	4	1	4	3 ¹⁵ / ₁₆	100.0	8 D 120 TB	A-1	4545	4 ¹ / ₂	1 ¹ / ₂	4 ¹ / ₂	6 ³ / ₁₆	125.0
6 D 130 TB	13.0	13.6	A-2	4040	4	1 ¹ / ₂	4	3 ³ / ₁₆	100.0	8 D 130 TB	A-1	4545	4 ¹ / ₂	1 ¹ / ₂	4 ¹ / ₂	6 ³ / ₁₆	155.0
6 D 135 TB	13.5	14.1	A-2	4040	4	1 ¹ / ₂	4	3 ³ / ₁₆	107.0	8 D 135 TB	A-2	4545	4 ¹ / ₂	1	4 ¹ / ₂	6 ³ / ₁₆	150.0
6 D 140 TB	14.0	14.6	A-2	4040	4	1 ¹ / ₂	4	3 ³ / ₁₆	112.0	8 D 140 TB	A-1	4545	4 ¹ / ₂	1	4 ¹ / ₂	6 ³ / ₁₆	155.0
6 D 145 TB	14.5	15.1	A-2	4040	4	1 ¹ / ₂	4	3 ³ / ₁₆	117.0	8 D 145 TB	A-2	4545	4 ¹ / ₂	2	4 ¹ / ₂	5 ⁵ / ₁₆	155.0
6 D 150 TB	15.0	15.6	A-2	4040	4	1 ¹ / ₂	4	3 ³ / ₁₆	122.0	8 D 150 TB	A-2	4545	4 ¹ / ₂	2	4 ¹ / ₂	5 ⁵ / ₁₆	135.0
6 D 155 TB	15.5	16.1	A-2	4040	4	1 ¹ / ₂	4	3 ³ / ₁₆	127.0	8 D 155 TB	A-2	4545	4 ¹ / ₂	2	4 ¹ / ₂	5 ⁵ / ₁₆	165.0
6 D 160 TB	16.0	16.6	A-2	4040	4	1 ¹ / ₂	4	3 ³ / ₁₆	175.0	8 D 160 TB	A-2	4545	4 ¹ / ₂	2	4 ¹ / ₂	5 ⁵ / ₁₆	165.0
6 D 180 TB	18.0	18.6	A-2	4040	4	1 ¹ / ₂	4	3 ³ / ₁₆	185.0	8 D 180 TB	A-2	4545	4 ¹ / ₂	2 ¹ / ₂	4 ¹ / ₂	4 ⁹ / ₁₆	180.0
6 D 220 TB	22.0	22.6	A-3	4040	4	1 ¹ / ₂	4	3 ³ / ₁₆	210.0	8 D 220 TB	A-3	4545	4 ¹ / ₂	2 ¹ / ₂	4 ¹ / ₂	4 ⁹ / ₁₆	275.0
6 D 270 TB	27.0	27.6	A-3	4545	4 ¹ / ₂	1 ¹ / ₂	4 ¹ / ₂	2 ¹ / ₁₆	260.0	8 D 270 TB	A-3	4545	4 ¹ / ₂	2 ¹ / ₂	4 ¹ / ₂	4 ⁹ / ₁₆	345.0
6 D 330 TB	33.0	33.6	A-3	4545	4 ¹ / ₂	1 ¹ / ₂	4 ¹ / ₂	2 ¹ / ₁₆	340.0	8 D 330 TB	A-3	4545	4 ¹ / ₂	2 ¹ / ₂	4 ¹ / ₂	4 ⁹ / ₁₆	455.0

Taper Bushed Sheaves — D

Example: **10-D-120-TB**

10 Groove F = 14 ¹¹ / ₁₆									
Part Number	PD	OD	Type	Bush	Bush Max. Bore	E	L Thru Bore	M	Wt. Less Bush
	D Belt								
10 D 120 TB	12.0	12.6	A-1	4545	4 ¹ / ₂	2 ³ / ₁₆	4 ¹ / ₂	7 ¹⁵ / ₁₆	140.0
10 D 130 TB	13.0	13.6	A-1	4545	4 ¹ / ₂	2 ³ / ₁₆	4 ¹ / ₂	7 ¹⁵ / ₁₆	170.0
10 D 135 TB	13.5	14.1	A-2	4545	4 ¹ / ₂	2 ³ / ₁₆	4 ¹ / ₂	7 ¹⁵ / ₁₆	170.0
10 D 140 TB	14.0	14.6	A-2	4545	4 ¹ / ₂	2 ³ / ₁₆	4 ¹ / ₂	7 ¹⁵ / ₁₆	175.0
10 D 145 TB	14.5	15.1	A-2	4545	4 ¹ / ₂	2 ³ / ₁₆	4 ¹ / ₂	7 ¹⁵ / ₁₆	180.0
10 D 150 TB	15.0	15.6	A-2	4545	4 ¹ / ₂	2 ³ / ₁₆	4 ¹ / ₂	7 ¹⁵ / ₁₆	195.0
10 D 155 TB	15.5	16.1	A-2	4545	4 ¹ / ₂	2 ³ / ₁₆	4 ¹ / ₂	7 ¹⁵ / ₁₆	175.0
10 D 160 TB	16.0	16.6	A-2	4545	4 ¹ / ₂	2 ³ / ₁₆	4 ¹ / ₂	7 ¹⁵ / ₁₆	195.0
10 D 180 TB	18.0	18.6	A-2	4545	4 ¹ / ₂	4	4 ¹ / ₂	6 ³ / ₁₆	195.0
10 D 220 TB	22.0	22.6	A-3	4545	4 ¹ / ₂	4	4 ¹ / ₂	6 ³ / ₁₆	340.0
10 D 270 TB	27.0	27.6	A-3	4545	4 ¹ / ₂	4	4 ¹ / ₂	6 ³ / ₁₆	415.0
10 D 330 TB	33.0	33.6	A-3	4545	4 ¹ / ₂	4 ¹ / ₂	4 ¹ / ₂	5 ⁵ / ₁₆	485.0

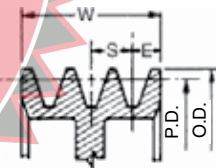
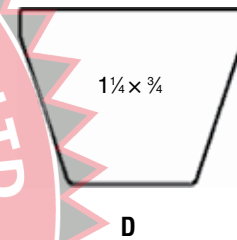

Groove Dimensions

Belt Section	E	S	OD
"D"	7 ¹ / ₁₆	1 ¹ / ₁₆	P.D. + .60

W = S(N-1) + 2E
N = No. of Grooves

Dimensions in inches, weight in pounds. Weights do not include bushings. See page B-8 thru B-10 for additional bushing dimensions.

PLEASE NOTE: Dashes are REQUIRED in place of spaces when ordering or searching on PTplace.com.

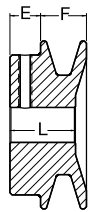

TYPE A
Solid

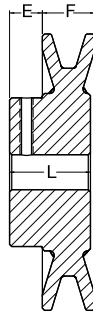

TYPE B
Web

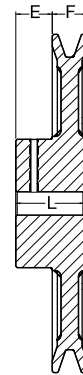

TYPE C
Arm / Spoke

FHP Sheave — AK

Nomenclature Example: **AK15-1/2**

Part Number	Diameter			Type	Stock Finished Bores Includes Keyway and Setscrew										F	E	L Thru Bore	Weight Lbs. (Approx.)			
	OD	Datum A(4L) Belts	Pitch 3L Belts		1	2	3	4	5	6	7	8	9	10					11	12	
AK15	1.55	1.30	-	A	1/2	-	5/8	-	-	-	-	-	-	-	-	-	21/32	7/16	1 3/32	0.3	
AK17	1.75	1.50	1.16	A	1/2	-	5/8	-	-	-	-	-	-	-	-	-	21/32	7/16	15/16	0.3	
AK19	1.95	1.70	1.36	A	1/2	-	5/8	-	3/4	-	7/8	-	-	-	-	-	21/32	7/16	15/16	0.5	
AK20	2.00	1.80	1.46	A	1/2	-	5/8	-	3/4	-	-	-	-	-	-	-	21/32	7/16	15/16	0.5	
AK21	2.10	1.90	1.56	A	1/2	-	5/8	-	3/4	-	-	-	-	-	-	-	21/32	7/16	15/16	0.5	
AK22	2.20	2.00	1.66	A	1/2	-	5/8	-	3/4	-	7/8	-	-	-	-	-	21/32	7/16	15/16	0.6	
AK23	2.30	2.10	1.76	A	1/2	-	5/8	-	3/4	-	-	-	-	-	-	-	21/32	7/16	15/16	0.6	
AK24	2.40	2.20	1.86	A	1/2	-	5/8	-	3/4	-	7/8	-	-	-	-	-	21/32	7/16	15/16	0.6	
AK25	2.50	2.30	1.96	B	1/2	-	5/8	-	3/4	-	7/8	-	-	-	-	-	21/32	7/16	15/16	0.7	
AK26	2.60	2.40	2.06	B	1/2	-	5/8	-	3/4	-	7/8	-	-	-	-	-	21/32	7/16	15/16	0.7	
AK27	2.70	2.50	2.16	B	1/2	-	5/8	-	3/4	-	7/8	-	-	-	-	-	21/32	7/16	15/16	0.8	
AK28	2.80	2.60	2.26	B	1/2	-	5/8	-	3/4	-	7/8	-	-	-	-	-	21/32	7/16	15/16	0.8	
AK30	3.05	2.80	2.46	B	1/2	-	5/8	-	3/4	-	7/8	-	-	-	-	-	21/32	7/16	15/16	0.9	
AK32	3.25	3.00	2.66	B	1/2	-	5/8	-	3/4	-	7/8	-	-	-	-	-	21/32	7/16	15/16	1.0	
AK34	3.45	3.20	2.86	B	1/2	-	5/8	-	3/4	-	7/8	-	-	-	-	-	21/32	7/16	15/16	1.1	
AK35	3.55	3.30	2.96	B	1/2	-	5/8	-	3/4	-	7/8	-	-	-	-	-	21/32	7/16	15/16	1.2	
AK39	3.75	3.50	3.16	B	1/2	-	5/8	-	3/4	-	7/8	-	15/16	-	-	-	3/4	15/32	1 1/32	1.6	
AK41	3.95	3.70	3.36	B	1/2	-	5/8	-	3/4	-	7/8	-	15/16	-	1	-	3/4	15/32	1 1/32	1.6	
AK44	4.25	4.00	3.66	B	1/2	-	5/8	-	3/4	-	7/8	-	15/16	-	1	-	3/4	15/32	1 1/32	1.9	
AK46	4.45	4.20	3.86	B	1/2	-	5/8	-	3/4	-	7/8	-	15/16	-	1	-	3/4	15/32	1 1/32	2.0	
AK49	4.75	4.50	4.16	B	1/2	-	5/8	-	3/4	-	7/8	-	15/16	-	1	-	3/4	15/32	1 1/32	2.1	
AK51	4.95	4.70	4.36	B	1/2	-	5/8	-	3/4	-	7/8	-	15/16	-	1	-	3/4	15/32	1 1/32	2.2	
AK54	5.25	5.00	4.66	B	1/2	-	5/8	-	3/4	-	7/8	-	15/16	-	1	-	3/4	15/32	1 1/32	2.4	
AK56	5.45	5.20	4.86	B	1/2	-	5/8	-	3/4	-	7/8	-	15/16	-	1	-	3/4	15/32	1 1/32	2.5	
AK59	5.75	5.50	5.16	C	1/2	-	5/8	-	3/4	-	7/8	-	15/16	-	1	-	3/4	15/32	1 1/32	2.7	
AK61	5.95	5.70	5.36	C	1/2	-	5/8	-	3/4	-	7/8	-	15/16	-	1	-	3/4	15/32	1 1/32	2.8	
AK64	6.25	6.00	5.66	C	1/2	-	5/8	-	3/4	-	7/8	-	15/16	-	1	-	3/4	15/32	1 1/32	3.0	
AK66	6.45	6.20	5.86	C	-	-	-	-	3/4	-	-	-	-	-	-	-	3/4	15/32	1 1/32	3.0	
AK69	6.75	6.50	6.16	C	-	-	-	-	3/4	-	-	-	-	-	-	-	3/4	23/32	1 1/32	3.7	
AK71	6.95	6.70	6.36	C	1/2	-	5/8	-	3/4	-	-	-	-	-	-	-	3/4	23/32	1 1/32	4.3	
AK74	7.25	7.00	6.66	C	1/2	-	5/8	-	3/4	-	-	15/16	-	1	-	1 1/8	-	1 1/16	-	1 1/16	4.5
AK79	7.75	7.50	7.16	C	-	-	-	-	3/4	-	-	-	-	-	-	-	3/4	23/32	*	1 1/32	4.7
AK81	7.95	7.70	7.36	C	-	-	-	-	5/8	-	3/4	-	-	-	-	-	3/4	23/32	*	1 1/32	4.7
AK84	8.25	8.00	7.66	C	1/2	-	5/8	-	3/4	-	-	15/16	-	1	-	-	3/4	23/32	*	1 1/32	5.0
AK89	8.75	8.50	8.16	C	-	-	-	-	3/4	-	-	-	-	-	-	-	3/4	23/32	*	1 1/32	5.2
AK91	8.95	8.70	8.36	C	-	-	-	-	3/4	-	-	-	-	-	-	-	3/4	23/32	*	1 1/32	5.2
AK94	9.25	9.00	8.66	C	1/2	-	5/8	-	3/4	-	-	15/16	-	1	-	1 1/8	-	1 1/16	-	1 1/16	5.5
AK99	9.75	9.50	9.16	C	-	-	-	-	3/4	-	-	-	-	-	-	-	3/4	23/32	*	1 1/32	5.7
AK104	10.25	10.00	9.66	C	-	-	-	-	5/8	-	3/4	-	-	-	-	-	3/4	23/32	*	1 1/32	5.9
AK109	10.75	10.50	10.16	C	-	-	-	-	3/4	-	-	-	-	-	-	-	3/4	23/32	*	1 1/32	6.1
AK114	11.25	11.00	10.66	C	-	-	-	-	3/4	-	-	-	-	-	-	-	3/4	23/32	*	1 1/32	6.7
AK124	12.25	12.00	11.66	C	-	-	-	-	5/8	-	3/4	-	-	-	-	-	3/4	23/32	*	1 1/32	7.3
AK134	13.25	13.00	12.66	C	-	-	-	-	3/4	-	-	-	-	-	-	-	3/4	23/32	*	1 1/32	8.2
AK144	14.25	14.00	13.66	C	-	-	-	-	3/4	-	-	-	-	-	-	-	3/4	23/32	*	1 1/32	8.7
AK154	15.25	15.00	14.66	C	-	-	-	-	3/4	-	-	-	-	-	-	-	3/4	23/32	*	1 1/32	9.7
AK184	18.25	18.00	17.66	C	-	-	-	-	3/4	-	-	-	-	-	-	-	3/4	23/32	*	1 1/32	11.8

E = 25/32 FOR BORE SIZES <= 1
1/2" Bore - setscrew only - no keyway

PLEASE NOTE: Dashes are REQUIRED in place of spaces when ordering or searching on PTplace.com.

Keyway Dimensions Inch Bore

Diameter Of Shaft	Keyway Width x Depth
1/2	NONE
5/8 - 7/8	3/16 x 3/32
15/16 - 1-1/4	1/4 x 1/8
1-5/16 - 1-3/8	5/16 x 5/32
1-7/16 - 1-3/4	3/8 x 3/16

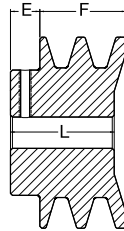

TYPE A
Solid

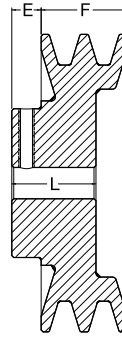

TYPE B
Web

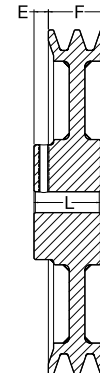

TYPE C
Arm / Spoke

FHP Sheave — 2AK

Nomenclature Example: **2AK20-1/2**

Part Number	Diameter			Type	Stock Finished Bores Includes Keyway and Setscrew	F	E	L Thru Bore	Weight Lbs. (Approx.)
	OD	Datum A(4L) Belts	Pitch 3L Belts						
2AK20	2.00	1.80	1.46	A	1/2 - 5/8 - 3/4	1 3/8	1 5/32	1 21/32	0.8
2AK21	2.15	1.90	1.56	A	1/2 - 5/8 - 3/4	1 3/8	1 5/32	1 21/32	0.9
2AK22	2.25	2.00	1.66	A	1/2 - 5/8 - 3/4 - 7/8 - - - 1	1 3/8	1 5/32	1 21/32	1.1
2AK23	2.35	2.10	1.76	A	5/8 - 3/4 - 7/8 - - - 1	1 3/8	1 5/32	1 21/32	1.2
2AK25	2.55	2.30	1.96	A	5/8 - 3/4 - 7/8 - - - 1	1 3/8	1 5/32	1 21/32	1.4
2AK26	2.65	2.40	2.06	A	5/8 - 3/4 - 7/8 - - - 1	1 3/8	1 5/32	1 21/32	1.5
2AK27	2.75	2.50	2.16	A	5/8 - 3/4 - 7/8 - - - 1	1 3/8	1 5/32	1 21/32	1.6
2AK28	2.85	2.60	2.26	A	5/8 - 3/4 - 7/8 - - - 1	1 3/8	1 5/32	1 21/32	1.7
2AK30	3.05	2.80	2.46	A	1/2 - 5/8 - 3/4 - 7/8 - - - 1 - 1 1/8	1 3/8	1 5/32	1 21/32	2.0
2AK32	3.25	3.00	2.66	A	5/8 - 3/4 - 7/8 - - - 1 - 1 1/8	1 3/8	1 5/32	1 21/32	2.2
2AK34	3.45	3.20	2.86	A	5/8 - 3/4 - 7/8 - - - 1 - 1 1/8	1 3/8	1 5/32	1 21/32	2.5
2AK39	3.75	3.50	3.16	B	5/8 - 3/4 - 7/8 - - - 1 - 1 1/8	1 3/8	1 5/32	1 11/32	2.6
2AK41	3.95	3.70	3.36	B	5/8 - 3/4 - 7/8 - - - 1 - 1 1/8	1 3/8	1 5/32	1 11/32	2.9
2AK44	4.25	4.00	3.66	B	5/8 - 3/4 - 7/8 - - - 1 - 1 1/8	1 3/8	1 5/32	1 11/32	3.3
2AK46	4.45	4.20	3.86	B	5/8 - 3/4 - 7/8 - - - 1 - 1 1/8	1 3/8	1 5/32	1 11/32	3.6
2AK49	4.75	4.50	4.16	B	5/8 - 3/4 - 7/8 - - - 1 - 1 1/8 - - - 1 3/8	1 3/8	1 5/32	1 11/32	3.8
2AK51	4.95	4.70	4.36	B	5/8 - 3/4 - 7/8 - - - 1 - 1 1/8 - - - 1 3/8	1 3/8	1 5/32	1 11/32	4.1
2AK54	5.25	5.00	4.66	B	5/8 - 3/4 - 7/8 - - - 1 - 1 1/8 - - - 1 3/8	1 3/8	1 5/32	1 11/32	4.3
2AK56	5.45	5.20	4.86	B	5/8 - 3/4 - 7/8 - - - 1 - 1 1/8 - - - 1 3/8	1 3/8	1 5/32	1 11/32	4.5
2AK59	5.75	5.50	5.16	B	5/8 - 3/4 - 7/8 - - - 1 - 1 1/8 - - - 1 3/8	1 3/8	1 5/32	1 11/32	4.9
2AK61	5.95	5.70	5.36	B	3/4 - 7/8 - - - 1 - 1 1/8 - - - 1 3/8	1 3/8	1 5/32	1 11/32	5.2
2AK64	6.25	6.00	5.66	C	3/4 - - - - 1 - 1 1/8 - 1 3/16 - 1 3/8 - 1 7/16	1 3/8	1 11/32	1 19/32	5.6
2AK74	7.25	7.00	6.66	C	3/4 - - - - 1 - 1 1/8 - 1 3/16 - 1 3/8 - 1 7/16	1 3/8	1 11/32	1 19/32	6.5
2AK84	8.25	8.00	7.66	C	3/4 - - - - 1 - 1 1/8 - 1 3/16 - 1 3/8 - 1 7/16	1 3/8	1 11/32	1 19/32	7.2
2AK94	9.25	9.00	8.66	C	3/4 - 7/8 - - - 1 - 1 1/8 - 1 3/16 - 1 3/8 - 1 7/16	1 3/8	1 11/32	1 19/32	8.0
2AK104	10.25	10.00	9.66	C	3/4 - - - - 1 - 1 1/8 - 1 3/16 - - - 1 7/16	1 3/8	1 11/32	1 19/32	9.0
2AK114	11.25	11.00	10.66	C	3/4 - - - - 1 - 1 1/8 - 1 3/16 - 1 3/8 - 1 7/16	1 3/8	1 11/32	1 19/32	9.7
2AK124	12.25	12.00	11.66	C	3/4 - - - - 1 - 1 1/8 - 1 3/16 - - - 1 7/16	1 3/8	1 11/32	1 19/32	10.5
2AK134	13.25	13.00	12.66	C	3/4 - - - - 1 - 1 1/8 - 1 3/16 - - - 1 7/16	1 3/8	1 11/32	1 19/32	12.7
2AK144	14.25	14.00	13.66	C	3/4 - - - - 1 - 1 1/8 - 1 3/16 - - - 1 7/16	1 3/8	1 11/32	1 19/32	13.1
2AK154	15.25	15.00	14.66	C	3/4 - - - - 1 - 1 1/8 - 1 3/16 - - - 1 7/16	1 3/8	1 11/32	1 19/32	14.3
2AK184	18.25	18.00	17.66	C	3/4 - - - - 1 - 1 1/8 - 1 3/16 - - - 1 7/16	1 3/8	1 11/32	1 19/32	17.1

1/2" Bore - setscrew only - no keyway

PLEASE NOTE: Dashes are REQUIRED in place of spaces when ordering or searching on PTplace.com.

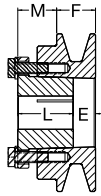

TYPE A
Solid

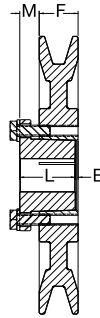

TYPE B
Web

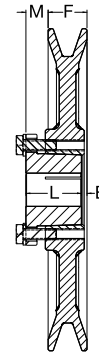

TYPE C
Arm / Spoke

FHP Sheave — AK-H

Nomenclature Example: **AK30-H**

Part Number	Diameter			Type	Bush	Bush Max. Bore	F	E	L Thru Bore	M	Weight Less Bush
	OD	Datum A(4L) Belts	Pitch 3L Belts								
AK30-H	3.05	2.80	2.46	A	H	1-1/2	3/4	3/8	1-1/4	7/8	1.3
AK32-H	3.25	3.00	2.66	A	H	1-1/2	3/4	3/8	1-1/4	7/8	1.4
AK34-H	3.45	3.20	2.86	A	H	1-1/2	3/4	1/16	1-1/4	9/16	1.2
AK39-H	3.75	3.50	3.16	A	H	1-1/2	3/4	1/16	1-1/4	9/16	1.4
AK41-H	3.95	3.70	3.36	A	H	1-1/2	3/4	1/16	1-1/4	9/16	1.6
AK44-H	4.25	4.00	3.66	A	H	1-1/2	3/4	1/16	1-1/4	9/16	2.0
AK46-H	4.45	4.20	3.86	A	H	1-1/2	3/4	1/16	1-1/4	9/16	2.2
AK49-H	4.75	4.50	4.16	B	H	1-1/2	3/4	1/16	1-1/4	9/16	2.1
AK51-H	4.95	4.70	4.36	B	H	1-1/2	3/4	1/16	1-1/4	9/16	2.3
AK54-H	5.25	5.00	4.66	B	H	1-1/2	3/4	1/16	1-1/4	9/16	2.3
AK56-H	5.45	5.20	4.86	B	H	1-1/2	3/4	1/16	1-1/4	9/16	2.4
AK59-H	5.75	5.50	5.16	B	H	1-1/2	3/4	1/16	1-1/4	9/16	2.5
AK61-H	5.95	5.70	5.36	C	H	1-1/2	3/4	1/16	1-1/4	9/16	2.6
AK64-H	6.25	6.00	5.66	C	H	1-1/2	3/4	1/16	1-1/4	9/16	2.8
AK66-H	6.45	6.20	5.86	C	H	1-1/2	3/4	1/16	1-1/4	9/16	2.8
AK69-H	6.75	6.50	6.16	C	H	1-1/2	3/4	1/16	1-1/4	9/16	3.0
AK71-H	6.95	6.70	6.36	C	H	1-1/2	3/4	1/16	1-1/4	9/16	3.0
AK74-H	7.25	7.00	6.66	C	H	1-1/2	3/4	1/16	1-1/4	9/16	3.3
AK79-H	7.75	7.50	7.16	C	H	1-1/2	3/4	1/16	1-1/4	9/16	3.5
AK84-H	8.25	8.00	7.66	C	H	1-1/2	3/4	1/16	1-1/4	9/16	3.8
AK89-H	8.75	8.50	8.16	C	H	1-1/2	3/4	1/16	1-1/4	9/16	4.0
AK94-H	9.25	9.00	8.66	C	H	1-1/2	3/4	1/16	1-1/4	9/16	4.4
AK99-H	9.75	9.50	9.16	C	H	1-1/2	3/4	1/16	1-1/4	9/16	4.7
AK104-H	10.25	10.00	9.66	C	H	1-1/2	3/4	1/16	1-1/4	9/16	5.0
AK109-H	10.75	10.50	10.16	C	H	1-1/2	3/4	1/16	1-1/4	9/16	5.2
AK114-H	11.25	11.00	10.66	C	H	1-1/2	3/4	1/16	1-1/4	9/16	5.5
AK124-H	12.25	12.00	11.66	C	H	1-1/2	3/4	1/16	1-1/4	9/16	6.0
AK134-H	13.25	13.00	12.66	C	H	1-1/2	3/4	1/16	1-1/4	9/16	7.3
AK144-H	14.25	14.00	13.66	C	H	1-1/2	3/4	1/16	1-1/4	9/16	7.9
AK154-H	15.25	15.00	14.66	C	H	1-1/2	3/4	1/16	1-1/4	9/16	8.9
AK184-H	18.25	18.00	17.66	C	H	1-1/2	3/4	1/16	1-1/4	9/16	11.4

Dimensions in inches, weight in pounds. Weights do not include bushings. See page D-58 for additional bushing information.

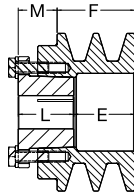

TYPE A
Solid

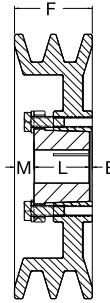

TYPE B
Web

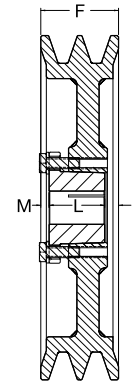

TYPE C
Arm / Spoke

FHP Sheave — 2AK-H

Nomenclature Example: **2AK30-H**

Part Number	Diameter			Type	Bush	Bush Max. Bore	F	E	L Thru Bore	M	Weight Less Bush
	OD	Datum A(4L) Belts	Pitch 3L Belts								
2AK30-H	3.05	2.80	2.46	A	H	1-1/2	1-3/8	1	1-1/4	7/8	1.7
2AK32-H	3.25	3.00	2.66	A	H	1-1/2	1-3/8	1	1-1/4	7/8	1.9
2AK34-H	3.45	3.20	2.86	A	H	1-1/2	1-3/8	9/16	1-1/4	7/16	1.7
2AK39-H	3.75	3.50	3.16	A	H	1-1/2	1-3/8	9/16	1-1/4	7/16	2.0
2AK41-H	3.95	3.70	3.36	B	H	1-1/2	1-3/8	1/16	1-1/4	1/16	2.2
2AK44-H	4.25	4.00	3.66	B	H	1-1/2	1-3/8	1/16	1-1/4	1/16	2.7
2AK46-H	4.45	4.20	3.86	B	H	1-1/2	1-3/8	1/16	1-1/4	1/16	3.0
2AK49-H	4.75	4.50	4.16	B	H	1-1/2	1-3/8	1/16	1-1/4	1/16	3.1
2AK51-H	4.95	4.70	4.36	B	H	1-1/2	1-3/8	1/16	1-1/4	1/16	3.5
2AK54-H	5.25	5.00	4.66	B	H	1-1/2	1-3/8	1/16	1-1/4	1/16	3.4
2AK56-H	5.45	5.20	4.86	B	H	1-1/2	1-3/8	1/16	1-1/4	1/16	3.6
2AK59-H	5.75	5.50	5.16	C	H	1-1/2	1-3/8	1/16	1-1/4	1/16	3.4
2AK61-H	5.95	5.70	5.36	C	H	1-1/2	1-3/8	1/16	1-1/4	1/16	3.7
2AK64-H	6.25	6.00	5.66	C	H	1-1/2	1-3/8	1/16	1-1/4	1/16	3.9
2AK74-H	7.25	7.00	6.66	C	H	1-1/2	1-3/8	1/16	1-1/4	1/16	5.0
2AK84-H	8.25	8.00	7.66	C	H	1-1/2	1-3/8	1/16	1-1/4	1/16	5.6
2AK94-H	9.25	9.00	8.66	C	H	1-1/2	1-3/8	1/16	1-1/4	1/16	6.3
2AK104-H	10.25	10.00	9.66	C	H	1-1/2	1-3/8	1/16	1-1/4	1/16	7.6
2AK114-H	11.25	11.00	10.66	C	H	1-1/2	1-3/8	1/16	1-1/4	1/16	8.4
2AK124-H	12.25	12.00	11.66	C	H	1-1/2	1-3/8	1/16	1-1/4	1/16	9.2
2AK134-H	13.25	13.00	12.66	C	H	1-1/2	1-3/8	1/16	1-1/4	1/16	11.5
2AK144-H	14.25	14.00	13.66	C	H	1-1/2	1-3/8	1/16	1-1/4	1/16	11.8
2AK154-H	15.25	15.00	14.66	C	H	1-1/2	1-3/8	1/16	1-1/4	1/16	13.3
2AK184-H	18.25	18.00	17.66	C	H	1-1/2	1-3/8	1/16	1-1/4	1/16	16.9

Dimensions in inches, weight in pounds. Weights do not include bushings. See page D-58 for additional bushing information.

MST "H" Bushings – Inch Bore

Diameter Of Shaft	Keyway Width x Depth	Diameter Of Shaft	Keyway Width x Depth
3/8	NONE	1	1/4 x 1/8
7/16	NONE	1-1/16	1/4 x 1/8
1/2	1/8 x 1/16	1-1/8	1/4 x 1/8
9/16	1/8 x 1/16	1-3/16	1/4 x 1/8
19/32	1/8 x 1/16	1-1/4	1/4 x 1/8
5/8	3/16 x 3/32	1-5/16	5/16 x 1/16
21/32	3/16 x 3/32	1-3/8	5/16 x 1/16
11/16	3/16 x 3/32	1-3/8	3/8 x 1/16
3/4	3/16 x 3/32	1-7/16	3/8 x 1/16
25/32	3/16 x 3/32	1-1/2	3/8 x 1/32
13/16	3/16 x 3/32		
7/8	3/16 x 3/32		
15/16	1/4 x 1/8		
31/32	1/4 x 1/8		

MST "H" Bushings – Millimeter Bore

Diameter Of Shaft	Keyway Width x Depth	Diameter Of Shaft	Keyway Width x Depth
10	NONE	22	6 x 2.8
11	NONE	24	8 x 3.3
12	NONE	25	8 x 3.3
14	5 x 2.3	28	8 x 3.3
16	5 x 2.3	30	8 x 3.3
18	6 x 2.8	32	10 x 1.3
19	6 x 2.8	35	10 x 0.3
20	6 x 2.8	36	10 x 1.3
		38	10 x 0.3

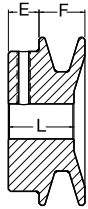

TYPE A
Solid

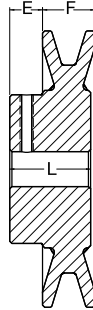

TYPE B
Web

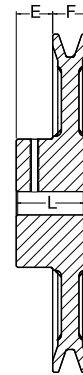

TYPE C
Arm / Spoke

FHP Sheave — BK

Nomenclature Example: **BK23-5/8**

Part Number	Diameter			Type	Stock Finished Bores Includes Keyway and Setscrew	F	E	L Thru Bore	Weight Lbs. (Approx.)
	OD	Datum A(4L) Belts	Datum B(5L) Belts						
BK23	2.30	-	2.10	A	5/8 - - - - - 1	13/16	13/32	1 1/16	0.4
BK24	2.40	1.80	2.20	A	1/2 - 5/8 - 3/4 - 7/8 - - -	13/16	13/32	1 1/16	0.4
BK25	2.50	1.90	2.30	A	1/2 - 5/8 - 3/4 - 7/8 - - -	13/16	13/32	1 1/16	0.5
BK26	2.60	2.00	2.40	A	1/2 - 5/8 - 3/4 - 7/8 - - -	13/16	13/32	1 1/16	0.6
BK27	2.70	2.10	2.50	B	1/2 - 5/8 - 3/4 - 7/8 - - - 1 1/8	13/16	13/32	1 1/16	0.6
BK28	2.95	2.20	2.60	B	1/2 - 5/8 - 3/4 - 7/8 - - - 1 - 1/8	13/16	13/32	1 1/16	0.8
BK30	3.15	2.40	2.80	B	1/2 - 5/8 - 3/4 - 7/8 - - - 1 - 1/8	13/16	13/32	1 1/16	0.8
BK32	3.35	2.60	3.00	B	1/2 - 5/8 - 3/4 - 7/8 - - - 1 - 1/8	13/16	13/32	1 1/16	0.8
BK34	3.55	2.80	3.20	B	1/2 - 5/8 - 3/4 - 7/8 - - - 1 - 1/8	7/8	13/32	1 1/32	1.3
BK36	3.75	3.00	3.40	B	1/2 - 5/8 - 3/4 - 7/8 - - - 1 - 1/8	7/8	13/32	1 1/32	1.5
BK40	3.95	3.20	3.60	B	1/2 - 5/8 - 3/4 - 7/8 - - - 1 - 1/8	7/8	13/32	1 1/32	1.5
BK45	4.25	3.50	3.90	B	1/2 - 5/8 - 3/4 - 7/8 - - - 1 - 1/8	7/8	13/32	1 1/32	1.8
BK46	4.35	3.60	4.00	B	- - - - - 7/8 - - - - -	7/8	13/32	1 1/32	1.8
BK47	4.45	3.70	4.10	B	1/2 - 5/8 - 3/4 - 7/8 - - - 1 - 1/8	7/8	13/32	1 1/32	1.8
BK48	4.55	3.80	4.20	B	1/2 - 5/8 - 3/4 - 7/8 - - - 1 - 1/8	7/8	13/32	1 1/32	2.0
BK50	4.75	4.00	4.40	B	1/2 - 5/8 - 3/4 - 7/8 - 15/16 - - - 1 - 1/8	7/8	13/32	1 1/32	2.0
BK52	4.95	4.20	4.60	B	1/2 - 5/8 - 3/4 - 7/8 - - - 1 - 1/8	7/8	13/32	1 1/32	2.0
BK55	5.25	4.50	4.90	B	1/2 - 5/8 - 3/4 - 7/8 - - - 1 - 1/8 - 13/16	7/8	13/32	1 1/32	2.2
BK57	5.45	4.70	5.10	B	- - - - - 3/4 - 7/8 - 15/16 - - - 1 - 1/8 - 13/16	7/8	13/32	1 1/32	2.3
BK60	5.75	5.00	5.40	B	1/2 - 5/8 - 3/4 - 7/8 - - - 1 - 1/8 - 13/16	7/8	13/32	1 1/32	2.3
BK62	5.95	5.20	5.60	B	1/2 - 5/8 - 3/4 - 7/8 - 15/16 - - - 1 - 1/8 - 13/16	7/8	13/32	1 1/32	2.4
BK65	6.25	5.50	5.90	B	5/8 - - - 3/4 - 7/8 - - - 1 - 1/8 - - -	7/8	13/32	1 1/32	2.7
BK67	6.45	5.70	6.10	C	5/8 - - - 3/4 - 7/8 - - - 1 - 1/8 - - -	7/8	13/32	1 1/32	2.8
BK70	6.75	6.00	6.40	C	5/8 - - - 3/4 - 7/8 - 15/16 - - - 1 - 1/8 - 13/16 - - - 1 1/16	7/8	2 1/32 *	1 15/32	3.3
BK72	6.95	6.20	6.60	C	- - - 3/4 - - - - - 1 - 1/8 - - - - - 1 3/8 - 1 1/16	7/8	2 1/32	1 15/32	3.9
BK75	7.25	6.50	6.90	C	- - - 3/4 - - - - - 1 - 1/8 - - - - - 1 1/16	7/8	2 1/32	1 15/32	3.9
BK77	7.45	6.70	7.10	C	- - - 3/4 - - - - - 1 - 1/8 - - - - - 1 3/8 - 1 1/16	7/8	2 1/32	1 15/32	4.1
BK80	7.75	7.00	7.40	C	5/8 - 3/4 - 7/8 - - - 1 - 1/8 - 13/16 - 1 1/4 - 1 3/8 - 1 1/16	7/8	2 1/32	1 15/32	4.4
BK85	8.25	7.50	7.90	C	- - - 3/4 - - - - - 1 - 1/8 - 13/16 - - - 1 3/8 - 1 1/16	7/8	2 1/32	1 15/32	5.0
BK90	8.75	8.00	8.40	C	- - - 3/4 - 7/8 - 15/16 - - - 1 - 1/8 - 13/16 - - - 1 3/8 - 1 1/16	7/8	2 1/32	1 15/32	5.0
BK95	9.25	8.50	8.90	C	- - - 3/4 - - - - - 1 - 1/8 - - - - - 1 3/8 - 1 1/16	7/8	2 1/32	1 15/32	5.4
BK100	9.75	9.00	9.40	C	- - - 3/4 - 7/8 - - - 1 - 1/8 - 13/16 - 1 1/4 - 1 3/8 - 1 1/16	7/8	2 1/32	1 15/32	5.6
BK105	10.25	9.50	9.90	C	- - - - - - - - - 1 - - - - - 1 3/8 - 1 1/16	7/8	2 1/32	1 15/32	5.8
BK110	10.75	10.00	10.40	C	- - - 3/4 - - - - - 1 - 1/8 - 13/16 - - - 1 3/8 - 1 1/16	7/8	2 1/32	1 15/32	6.4
BK115	11.25	10.50	10.90	C	- - - - - - - - - 1 - - - - - 1 3/8 - 1 1/16	7/8	2 1/32	1 15/32	6.9
BK120	11.75	11.00	11.40	C	- - - 3/4 - - - - - 1 - - - - - 1 3/8 - 1 1/16	7/8	2 1/32	1 15/32	7.4
BK130	12.75	12.00	12.40	C	- - - 3/4 - 7/8 - - - 1 - 1/8 - 13/16 - - - 1 1/16	7/8	2 1/32	1 15/32	8.4
BK140	13.75	13.00	13.40	C	- - - 3/4 - - - - - 1 - - - - - 1 1/16	7/8	2 1/32	1 15/32	9.4
BK160	15.75	15.00	15.40	C	- - - 1 - 1/8 - 13/16 - 1 1/4 - - - 1 1/16	7/8	2 1/32	1 15/32	11.4
BK190	18.75	18.00	18.40	C	- - - 1 - - - 13/16 - 1 1/4 - - - 1 1/16	7/8	2 1/32	1 15/32	13.4

E = 13/32 FOR BORE SIZES <= 1
1/2" Bore - setscrew only - no keyway

PLEASE NOTE: Dashes are REQUIRED in place of spaces when ordering or searching on PTplace.com.

V-Belt | FHP Sheaves

Keyway Dimensions Inch Bore

Diameter Of Shaft	Keyway Width x Depth
1/2	NONE
5/8 - 7/8	3/16 x 3/32
15/16 - 1-1/4	1/4 x 1/8
1-5/16 - 1-3/8	5/16 x 5/32
1-7/16 - 1-3/4	3/8 x 3/16

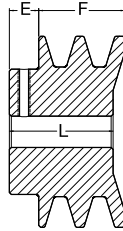

TYPE A
Solid

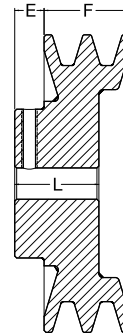

TYPE B
Web

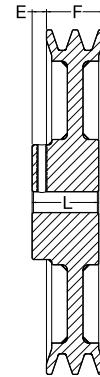

TYPE C
Arm / Spoke

FHP Sheave — 2BK

Nomenclature Example: **2BK25-1/2**

Part Number	Diameter			Type	Stock Finished Bores Includes Keyway and Setscrew	F	E	L Thru Bore	Weight Lbs. (Approx.)
	OD	Datum A(4L) Belts	Datum B(5L) Belts						
2BK25	2.50	1.90	2.30	A	1/2 - 5/8 - 3/4 - 7/8	1 3/4	1 5/32	1 31/32	1.3
2BK26	2.60	2.00	2.40	A	5/8 - 7/8 - 1 - 1 1/8	1 3/4	1 5/32	1 31/32	1.5
2BK27	2.70	2.10	2.50	A	1/2 - 5/8 - 3/4 - 7/8 - 1 - 1 1/8	1 3/4	1 5/32	1 31/32	1.6
2BK28	2.95	2.20	2.60	A	1/2 - 5/8 - 3/4 - 7/8 - 1 - 1 1/8	1 3/4	1 5/32	1 31/32	1.9
2BK30	3.15	2.40	2.80	A	1/2 - 5/8 - 3/4 - 7/8 - 1 - 1 1/8	1 3/4	1 5/32	1 31/32	2.3
2BK32	3.35	2.60	3.00	A	5/8 - 7/8 - 1 - 1 1/8	1 3/4	1 5/32	1 31/32	2.6
2BK34	3.55	2.80	3.20	A	5/8 - 3/4 - 7/8 - 1 - 1 1/8	1 3/4	1 5/32	1 31/32	2.8
2BK36	3.75	3.00	3.40	A	5/8 - 3/4 - 7/8 - 1 - 1 1/8 - 1 3/8	1 3/4	1 5/32	1 31/32	3.3
2BK40	3.95	3.20	3.60	B	5/8 - 3/4 - 7/8 - 1 - 1 1/8	1 3/4	1 5/32	1 15/32	3.3
2BK45	4.25	3.50	3.90	B	5/8 - 3/4 - 7/8 - 1 - 1 1/8 - 1 3/8	1 3/4	1 5/32	1 15/32	3.3
2BK47	4.45	3.70	4.10	B	7/8 - 1 - 1 1/8 - 1 3/8	1 3/4	1 5/32	1 15/32	3.7
2BK50	4.75	4.00	4.40	B	3/4 - 7/8 - 1 - 1 1/8 - 1 3/8	1 3/4	1 5/32	1 15/32	4.1
2BK52	4.95	4.20	4.60	B	7/8 - 1 - 1 1/8 - 1 3/8	1 3/4	1 5/32	1 15/32	4.5
2BK55	5.25	4.50	4.90	B	7/8 - 1 - 1 1/8 - 1 3/8	1 3/4	1 5/32	1 15/32	4.5
2BK57	5.45	4.70	5.10	B	7/8 - 1 - 1 1/8 - 1 3/8	1 3/4	1 5/32	1 15/32	5.1
2BK60	5.75	5.00	5.40	B	3/4 - 7/8 - 1 - 1 1/8 - 1 3/8	1 3/4	1 5/32	1 15/32	4.9
2BK62	5.95	5.20	5.60	B	7/8 - 1 - 1 1/8 - 1 3/8	1 3/4	1 5/32	1 15/32	4.8
2BK65	6.25	5.50	5.90	B	7/8 - 1 - 1 1/8 - 1 3/8	1 3/4	1 5/32	1 15/32	5.0
2BK67	6.45	5.70	6.10	C	7/8 - 1 - 1 1/8 - 1 3/8	1 3/4	1 5/32	1 15/32	5.0
2BK70	6.75	6.00	6.40	C	3/4 - 7/8 - 1 - 1 1/8 - 1 3/16 - 1 3/8 - 1 7/16	1 3/4	1 11/32	1 19/32	6.6
2BK80	7.75	7.00	7.40	C	3/4 - 7/8 - 1 - 1 1/8 - 1 3/16 - 1 3/8 - 1 7/16	1 3/4	1 11/32	1 19/32	7.2
2BK90	8.75	8.00	8.40	C	3/4 - 7/8 - 1 - 1 1/8 - 1 3/16 - 1 3/8 - 1 7/16	1 3/4	1 11/32	1 19/32	8.4
2BK100	9.75	9.00	9.40	C	3/4 - 7/8 - 1 - 1 1/8 - 1 3/16 - 1 3/8 - 1 7/16	1 3/4	1 11/32	1 19/32	9.4
2BK110	10.75	10.00	10.40	C	7/8 - 1 - 1 1/8 - 1 3/16 - 1 3/8 - 1 7/16	1 3/4	1 11/32	1 19/32	10.4
2BK120	11.75	11.00	11.40	C	7/8 - 1 - 1 1/8 - 1 3/16 - 1 3/8 - 1 7/16	1 3/4	1 11/32	1 19/32	11.8
2BK130	12.75	12.00	12.40	C	1 - 1 1/8 - 1 3/16 - 1 3/8 - 1 7/16	1 3/4	1 11/32	1 19/32	14.9
2BK140	13.75	13.00	13.40	C	1 - 1 1/8 - 1 3/16 - 1 3/8 - 1 7/16	1 3/4	1 11/32	1 19/32	16.3
2BK160	15.75	15.00	15.40	C	1 - 1 1/8 - 1 3/16 - 1 3/8 - 1 7/16	1 3/4	1 11/32	1 19/32	18.0
2BK190	18.75	18.00	18.40	C	1 - 1 1/8 - 1 3/16 - 1 3/8 - 1 7/16	1 3/4	1 11/32	1 19/32	23.3

1/2" Bore - setscrew only - no keyway

PLEASE NOTE: Dashes are REQUIRED in place of spaces when ordering or searching on PTplace.com.

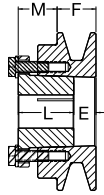

TYPE A
Solid

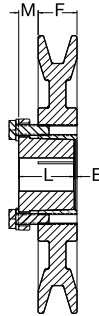

TYPE B
Web

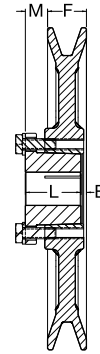

TYPE C
Arm / Spoke

FHP Sheave — BK-H

Nomenclature Example: **BK30-H**

Part Number	Diameter			Type	Bush	Bush Max. Bore	F	E	L Thru Bore	M	Weight Less Bush
	OD	Datum A(4L) Belts	Datum B(5L) Belts								
BK30-H	3.15	2.40	2.80	A	H	1-1/2	7/8	1/2	1-1/4	7/8	1.3
BK32-H	3.35	2.60	3.00	A	H	1-1/2	7/8	1/2	1-1/4	7/8	1.5
BK34-H	3.55	2.80	3.20	A	H	1-1/2	7/8	1/2	1-1/4	7/8	1.7
BK36-H	3.75	3.00	3.40	B	H	1-1/2	7/8	1/16	1-1/4	7/16	1.3
BK40-H	3.95	3.20	3.60	B	H	1-1/2	7/8	1/16	1-1/4	7/16	1.5
BK45-H	4.25	3.50	3.90	B	H	1-1/2	7/8	1/16	1-1/4	7/16	1.9
BK47-H	4.45	3.70	4.10	B	H	1-1/2	7/8	1/16	1-1/4	7/16	2.2
BK50-H	4.75	4.00	4.40	B	H	1-1/2	7/8	1/16	1-1/4	7/16	2.2
BK52-H	4.95	4.20	4.60	B	H	1-1/2	7/8	1/16	1-1/4	7/16	2.5
BK55-H	5.25	4.50	4.90	B	H	1-1/2	7/8	1/16	1-1/4	7/16	3.0
BK57-H	5.45	4.70	5.10	B	H	1-1/2	7/8	1/16	1-1/4	7/16	3.2
BK60-H	5.75	5.00	5.40	B	H	1-1/2	7/8	1/16	1-1/4	7/16	3.2
BK62-H	5.95	5.20	5.60	B	H	1-1/2	7/8	1/16	1-1/4	7/16	3.6
BK65-H	6.25	5.50	5.90	B	H	1-1/2	7/8	1/16	1-1/4	7/16	4.0
BK67-H	6.45	5.70	6.10	B	H	1-1/2	7/8	1/16	1-1/4	7/16	4.2
BK70-H	6.75	6.00	6.40	C	H	1-1/2	7/8	1/8	1-1/4	1/2	3.3
BK72-H	6.95	6.20	6.60	C	H	1-1/2	7/8	1/8	1-1/4	1/2	3.6
BK75-H	7.25	6.50	6.90	C	H	1-1/2	7/8	1/8	1-1/4	1/2	3.4
BK77-H	7.45	6.70	7.10	C	H	1-1/2	7/8	1/8	1-1/4	1/2	3.7
BK80-H	7.75	7.00	7.40	C	H	1-1/2	7/8	1/8	1-1/4	1/2	4.0
BK85-H	8.25	7.50	7.90	C	H	1-1/2	7/8	1/8	1-1/4	1/2	4.1
BK90-H	8.75	8.00	8.40	C	H	1-1/2	7/8	1/8	1-1/4	1/2	4.5
BK95-H	9.25	8.50	8.90	C	H	1-1/2	7/8	1/8	1-1/4	1/2	4.8
BK100-H	9.75	9.00	9.40	C	H	1-1/2	7/8	1/8	1-1/4	1/2	5.1
BK105-H	10.25	9.50	9.90	C	H	1-1/2	7/8	1/8	1-1/4	1/2	5.4
BK110-H	10.75	10.00	10.40	C	H	1-1/2	7/8	1/8	1-1/4	1/2	6.0
BK115-H	11.25	10.50	10.90	C	H	1-1/2	7/8	1/8	1-1/4	1/2	6.3
BK120-H	11.75	11.00	11.40	C	H	1-1/2	7/8	1/8	1-1/4	1/2	6.6
BK130-H	12.75	12.00	12.40	C	H	1-1/2	7/8	1/8	1-1/4	1/2	7.2
BK140-H	13.75	13.00	13.40	C	H	1-1/2	7/8	1/8	1-1/4	1/2	8.6
BK150-H	14.75	14.00	14.40	C	H	1-1/2	7/8	1/8	1-1/4	1/2	9.4
BK160-H	15.75	15.00	15.40	C	H	1-1/2	7/8	1/8	1-1/4	1/2	10.1
BK190-H	18.75	18.00	18.40	C	H	1-1/2	7/8	1/8	1-1/4	1/2	12.3

Dimensions in inches, weight in pounds. Weights do not include bushings. See page D-58 for additional bushing information.

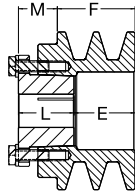

TYPE A
Solid

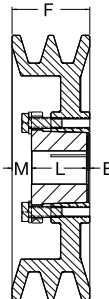

TYPE B
Web

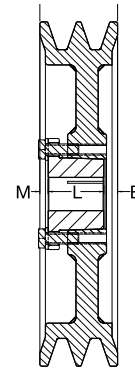

TYPE C
Arm / Spoke

FHP Sheave — 2BK-H

Nomenclature Example: **2BK32-H**

Part Number	Diameter			Type	Bush	Bush Max. Bore	F	E	L Thru Bore	M	Weight Less Bush
	OD	Datum A(4L) Belts	Datum B(5L) Belts								
2BK32-H	3.35	2.60	3.00	A	H	1-1/2	1-3/4	1-3/8	1-1/4	7/8	2.2
2BK34-H	3.55	2.80	3.20	A	H	1-1/2	1-3/4	1-3/8	1-1/4	7/8	2.6
2BK36-H	3.75	3.00	3.40	A	H	1-1/2	1-3/4	15/16	1-1/4	7/16	2.4
2BK40-H	3.95	3.20	3.60	A	H	1-1/2	1-3/4	15/16	1-1/4	7/16	2.6
2BK45-H	4.25	3.50	3.90	A	H	1-1/2	1-3/4	15/16	1-1/4	7/16	3.1
2BK47-H	4.45	3.70	4.10	B	H	1-1/2	1-3/4	1/16	1-1/4	7/16	3.2
2BK50-H	4.75	4.00	4.40	B	H	1-1/2	1-3/4	1/16	1-1/4	7/16	3.7
2BK52-H	4.95	4.20	4.60	B	H	1-1/2	1-3/4	1/16	1-1/4	7/16	4.1
2BK55-H	5.25	4.50	4.90	B	H	1-1/2	1-3/4	1/16	1-1/4	7/16	4.2
2BK57-H	5.45	4.70	5.10	B	H	1-1/2	1-3/4	1/16	1-1/4	7/16	4.5
2BK60-H	5.75	5.00	5.40	B	H	1-1/2	1-3/4	1/16	1-1/4	7/16	4.9
2BK62-H	5.95	5.20	5.60	B	H	1-1/2	1-3/4	1/16	1-1/4	7/16	5.2
2BK65-H	6.25	5.50	5.90	C	H	1-1/2	1-3/4	5/16	1-1/4	3/16	5.7
2BK67-H	6.45	5.70	6.10	C	H	1-1/2	1-3/4	5/16	1-1/4	3/16	5.8
2BK70-H	6.75	6.00	6.40	C	H	1-1/2	1-3/4	5/16	1-1/4	3/16	6.1
2BK72-H	6.95	6.20	6.60	C	H	1-1/2	1-3/4	5/16	1-1/4	3/16	6.1
2BK80-H	7.75	7.00	7.40	C	H	1-1/2	1-3/4	5/16	1-1/4	3/16	7.4
2BK90-H	8.75	8.00	8.40	C	H	1-1/2	1-3/4	5/16	1-1/4	3/16	8.5
2BK100-H	9.75	9.00	9.40	C	H	1-1/2	1-3/4	5/16	1-1/4	3/16	9.7
2BK110-H	10.75	10.00	10.40	C	H	1-1/2	1-3/4	5/16	1-1/4	3/16	10.9
2BK120-H	11.75	11.00	11.40	C	H	1-1/2	1-3/4	5/16	1-1/4	3/16	12.0
2BK130-H	12.75	12.00	12.40	C	H	1-1/2	1-3/4	5/16	1-1/4	3/16	13.4
2BK140-H	13.75	13.00	13.40	C	H	1-1/2	1-3/4	5/16	1-1/4	3/16	15.3
2BK160-H	15.75	15.00	15.40	C	H	1-1/2	1-3/4	5/16	1-1/4	3/16	17.8
2BK190-H	18.75	18.00	18.40	C	H	1-1/2	1-3/4	5/16	1-1/4	3/16	22.8

Dimensions in inches, weight in pounds. Weights do not include bushings. See page D-58 for additional bushing information.

MST "H" Bushings – Inch Bore

Diameter Of Shaft	Keyway Width x Depth	Diameter Of Shaft	Keyway Width x Depth
3/8	NONE	1	1/4 x 1/8
7/16	NONE	1-1/16	1/4 x 1/8
1/2	1/8 x 1/16	1-1/8	1/4 x 1/8
9/16	1/8 x 1/16	1-3/16	1/4 x 1/8
19/32	1/8 x 1/16	1-1/4	1/4 x 1/8
5/8	3/16 x 3/32	1-5/16	5/16 x 1/16
21/32	3/16 x 3/32	1-3/8	5/16 x 1/16
11/16	3/16 x 3/32	1-3/8	3/8 x 1/16
3/4	3/16 x 3/32	1-7/16	3/8 x 1/16
25/32	3/16 x 3/32	1-1/2	3/8 x 1/32
13/16	3/16 x 3/32		
7/8	3/16 x 3/32		
15/16	1/4 x 1/8		
31/32	1/4 x 1/8		

MST "H" Bushings – Millimeter Bore

Diameter Of Shaft	Keyway Width x Depth	Diameter Of Shaft	Keyway Width x Depth
10	NONE	22	6 x 2.8
11	NONE	24	8 x 3.3
12	NONE	25	8 x 3.3
14	5 x 2.3	28	8 x 3.3
16	5 x 2.3	30	8 x 3.3
18	6 x 2.8	32	10 x 1.3
19	6 x 2.8	35	10 x 0.3
20	6 x 2.8	36	10 x 1.3
		38	10 x 0.3

Keyway Dimensions Inch Bore

Diameter Of Shaft	Keyway Width X Depth
1/2	NONE
5/8 - 7/8	3/16 x 3/32
15/16 - 1-1/4	1/4 x 1/8
1-5/16 - 1-3/8	5/16 x 5/32
1-7/16 - 1-3/4	3/8 x 3/16

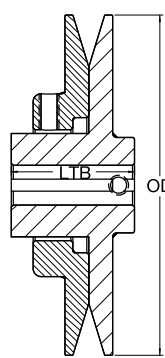

TYPE A

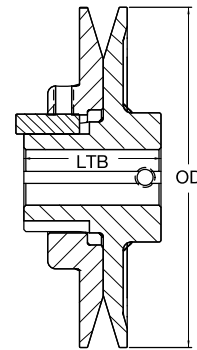

TYPE B

Belt Dimensions

Nomenclature Example: **1VP25** or **1VP25-1/2**

Part Number	Diameters And Turns															
	3L Belts				A or 4L Belts				B or 5L Belts				5V Belts			
	Min. Pitch	Turns Open	Max. Pitch	Turns Open	Min. Datum	Turns Open	Max. Datum	Turns Open	Min. Datum	Turns Open	Max. Datum	Turns Open	Min. Pitch	Turns Open	Max. Pitch	Turns Open
1VP25	1.6	4	2.4	0	-	-	-	-	-	-	-	-	-	-	-	-
1VP30	1.8	4	2.7	0	-	-	-	-	-	-	-	-	-	-	-	-
1VP34	1.9	4	2.8	0	2.0	5	3.0	0	2.3	5	3.2	1	-	-	-	-
1VP40	2.4	4	3.2	0	2.5	5	3.5	0	2.6	6	3.6	1	-	-	-	-
1VP44	2.8	4	3.7	0	2.9	5	3.9	0	3.0	6	4.0	1	-	-	-	-
1VP50	3.4	4	4.2	0	3.5	5	4.5	0	3.6	6	4.6	1	-	-	-	-
1VP56	4.0	4	4.8	0	4.1	5	5.1	0	4.2	6	5.2	1	-	-	-	-
1VP60	-	-	-	-	4.2	5	5.2	0	4.4	6	5.6	0	-	-	-	-
1VP62	4.6	4	5.4	0	4.7	5	5.7	0	4.8	6	5.8	1	5.1	6	6.1	1
1VP65	-	-	-	-	4.7	5	5.7	0	4.9	6	6.1	0	5.1	6	6.3	0
1VP68	5.2	4	6.0	0	5.3	5	6.3	0	5.4	6	6.4	1	5.7	6	6.7	1
1VP71	-	-	-	-	5.3	5	6.3	0	5.5	6	6.7	0	5.7	6	6.9	0
1VP75	-	-	-	-	5.7	5	6.7	0	5.9	6	7.1	0	6.1	6	7.3	0

Dimensions in Inches

Socket Size Dimensions

Part Number	OD	Type	L Thru Bore	Stock Finished Bores Includes Keyway and Setscrew												Wt. Lbs. (Approx.)	
				1/2	5/8	3/4	7/8	1	1-1/8	1-1/4	1-3/8	1-1/2	1-5/8	1-3/4	1-7/8		2
1VP25	2.50	A	1-23/32	1/2	-	5/8	-	3/4	-	-	-	-	-	-	-	-	0.8
1VP30	2.87	A	1-11/16	1/2	-	5/8	-	3/4	-	-	-	-	-	-	-	-	1.1
1VP34	3.15	A	1-29/32	1/2	-	5/8	-	3/4	-	7/8	-	-	-	-	-	-	1.4
1VP40	3.75	A	1-7/8	1/2	-	5/8	-	3/4	-	7/8	-	-	-	-	-	-	1.7
1VP44	4.15	A	1-7/8	1/2	-	5/8	-	3/4	-	7/8	-	-	-	-	-	-	2.4
1VP44	4.15	B	2-3/16	-	-	-	-	-	7/8	-	1	-	1-1/8	-	-	-	3.0
1VP50	4.75	A	2	1/2	-	5/8	-	3/4	-	-	-	-	-	-	-	-	2.7
1VP50	4.75	B	2-5/32	-	-	-	-	-	7/8	-	1	-	1-1/8	-	-	-	3.5
1VP56	5.35	A	1-15/16	1/2	-	5/8	-	3/4	-	-	-	-	-	-	-	-	4.1
1VP56	5.35	B	2-5/32	-	-	-	-	-	7/8	-	1	-	1-1/8	-	-	-	4.4
1VP60	6.00	B	2-7/32	-	-	5/8	-	3/4	-	7/8	-	1	-	1-1/8	-	1-3/8	6.3
1VP62	5.95	B	1-29/32	-	-	5/8	-	3/4	-	7/8	-	1	-	1-1/8	-	1-3/8	6.1
1VP65	6.50	B	2-7/32	-	-	-	-	3/4	-	7/8	-	-	-	1-1/8	-	1-3/8	7.1
1VP68	6.55	B	1-29/32	-	-	5/8	-	3/4	-	7/8	-	1	-	1-1/8	-	1-3/8	7.3
1VP71	7.10	B	2-7/32	-	-	-	-	3/4	-	7/8	-	-	-	1-1/8	-	1-3/8	8.2
1VP75	7.50	B	2-7/32	-	-	-	-	3/4	-	7/8	-	1	-	1-1/8	-	1-3/8	9.0

1/2" Bore - setscrew only - no keyway

Dimensions in Inches

PLEASE NOTE: Dashes are REQUIRED in place of spaces when ordering or searching on PTplace.com.

Keyway Dimensions Inch Bore

Diameter Of Shaft	Keyway Width x Depth
1/2	NONE
5/8 - 7/8	3/16 x 3/32
15/16 - 1-1/4	1/4 x 1/8
1-5/16 - 1-3/8	5/16 x 5/32
1-7/16 - 1-3/4	3/8 x 3/16

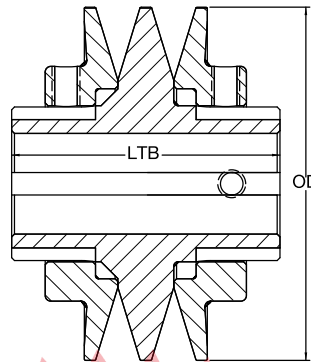

TYPE A

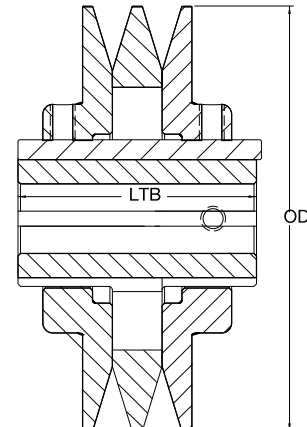

TYPE B

Belt Dimensions

Nomenclature Example: **2VP36** or **2VP36-1/2**

Part Number	Diameters And Turns															
	3L Belts				A or 4L Belts				B or 5L Belts				5V Belts			
	Min. Pitch	Turns Open	Max. Pitch	Turns Open	Min. Datum	Turns Open	Max. Datum	Turns Open	Min. Datum	Turns Open	Max. Datum	Turns Open	Min. Pitch	Turns Open	Max. Pitch	Turns Open
2VP36	2.0	4	2.8	0	2.1	5	3.1	0	2.4	5	3.2	1	-	-	-	-
2VP42	2.6	4	3.4	0	2.7	5	3.7	0	2.8	6	3.8	1	-	-	-	-
2VP50	3.4	4	4.2	0	3.5	5	4.5	0	3.6	6	4.6	1	-	-	-	-
2VP56	4.0	4	4.8	0	4.1	5	5.1	0	4.2	6	5.2	1	-	-	-	-
2VP60	-	-	-	-	4.2	5	5.2	0	4.4	6	5.6	0	-	-	-	-
2VP62	4.6	4	5.4	0	4.7	5	5.7	0	4.8	6	5.8	1	5.1	6	6.1	1
2VP65	-	-	-	-	4.7	5	5.7	0	4.9	6	6.1	0	5.1	6	6.3	0
2VP68	5.2	4	6.0	0	5.3	5	6.3	0	5.4	6	6.4	1	5.7	6	6.7	1
2VP71	-	-	-	-	5.3	5	6.3	0	5.5	6	6.7	0	5.7	6	6.9	0
2VP75	-	-	-	-	5.7	5	6.7	0	5.9	6	7.1	0	6.1	6	7.3	0

Dimensions in Inches

Sock Size Dimensions

Part Number	OD	Type	L Thru Bore	Stock Finished Bores Includes Keyway and Setscrew												Wt. Lbs. (Approx.)	
				1/2"	5/8"	3/4"	7/8"	1"	1-1/8"	1-1/4"	1-3/8"	1-1/2"	1-5/8"	1-3/4"			
2VP36	3.35	A	3	1/2	-	5/8	-	3/4	-	7/8	-	1	-	-	-	-	3.6
2VP42	3.95	A	3	-	5/8	-	3/4	-	7/8	-	1	-	1-1/8	-	-	-	4.5
2VP50	4.75	B	3	-	5/8	-	3/4	-	7/8	-	1	-	1-1/8	-	-	-	6.1
2VP56	5.35	B	3	-	5/8	-	3/4	-	7/8	-	1	-	1-1/8	-	-	-	7.5
2VP60	6.00	B	3-1/4	-	-	-	3/4	-	7/8	-	1	-	1-1/8	-	-	1-3/8	10.9
2VP62	5.95	B	3	-	-	-	3/4	-	7/8	-	1	-	1-1/8	-	-	1-3/8	10.0
2VP65	6.50	B	3-1/4	-	-	-	3/4	-	7/8	-	1	-	1-1/8	-	-	1-3/8	12.5
2VP68	6.55	B	3	-	-	-	3/4	-	7/8	-	1	-	1-1/8	-	1-1/4	-	11.7
2VP71	7.10	B	3-1/4	-	-	-	3/4	-	7/8	-	1	-	1-1/8	-	-	1-3/8	14.7
2VP75	7.50	B	3-1/4	-	-	-	3/4	-	7/8	-	1	-	1-1/8	-	-	1-3/8	16.3

1/2" Bore - setscrew only - no keyway

Dimensions in Inches

PLEASE NOTE: Dashes are REQUIRED in place of spaces when ordering or searching on PTplace.com.

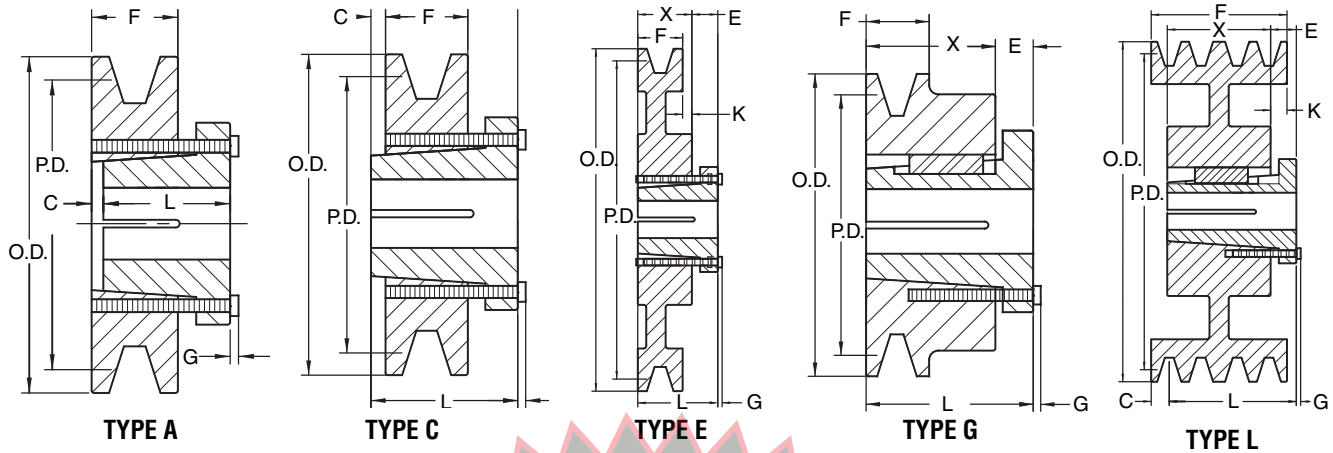

3V MST Sheaves

Nomenclature Example: 1-3V-265-G

1 Groove												
F = 11/16												
Part Number	OD	PD 3V Belt	Type	Bush	Bush Max. Bore	C	E	G	K	Length Thru Bore	X	Wt. Less Bushing
1 3V 265 G	2.65	2.60	A-1	G	1.00	0.13	-	0.19	0.06	1.00	0.63	0.60
1 3V 280 G	2.80	2.75	A-1	G	1.00	0.13	-	0.19	0.06	1.00	0.63	0.70
1 3V 300 G	3.00	2.95	A-1	G	1.00	0.13	-	0.19	0.06	1.00	0.63	0.90
1 3V 315 H	3.15	3.10	C-1	H	1.50	0.13	-	0.19	0.31	1.25	0.88	0.80
1 3V 335 H	3.35	3.30	C-1	H	1.50	0.13	-	0.19	0.31	1.25	0.88	0.90
1 3V 365 H	3.65	3.60	E-1	H	1.50	-	0.44	0.19	0.19	1.25	0.88	1.40
1 3V 365 P	3.65	3.60	G-1	P1	1.75	-	0.63	0.25	0.63	1.94	1.31	2.00
1 3V 412 H	4.12	4.07	E-1	H	1.50	-	0.44	0.19	0.19	1.25	0.88	1.90
1 3V 412 P	4.12	4.07	G-1	P1	1.75	-	0.63	0.25	0.63	1.94	1.31	2.60
1 3V 450 H	4.50	4.45	E-1	H	1.50	-	0.44	0.19	0.19	1.25	0.88	2.20
1 3V 450 P	4.50	4.45	G-1	P1	1.75	-	0.63	0.25	0.63	1.94	1.31	3.00
1 3V 475 H	4.75	4.70	E-1	H	1.50	-	0.44	0.19	0.19	1.25	0.88	2.40
1 3V 475 P	4.75	4.70	G-1	P1	1.75	-	0.63	0.25	0.63	1.94	1.31	3.50
1 3V 500 H	5.00	4.95	E-1	H	1.50	-	0.44	0.19	0.19	1.25	0.88	2.60
1 3V 500 P	5.00	4.95	G-1	P1	1.75	-	0.63	0.25	0.63	1.94	1.31	3.80
1 3V 530 H	5.30	5.25	E-1	H	1.50	-	0.44	0.19	0.19	1.25	0.88	2.50
1 3V 530 P	5.30	5.25	G-1	P1	1.75	-	0.63	0.25	0.63	1.94	1.31	4.20
1 3V 560 H	5.60	5.55	E-1	H	1.50	-	0.44	0.19	0.19	1.25	0.88	2.60
1 3V 560 P	5.60	5.55	G-1	P1	1.75	-	0.63	0.25	0.63	1.94	1.31	4.60
1 3V 600 H	6.00	5.95	E-1	H	1.50	-	0.44	0.19	0.19	1.25	0.88	2.90
1 3V 600 P	6.00	5.95	G-1	P1	1.75	-	0.63	0.25	0.63	1.94	1.31	5.30
1 3V 650 P	6.50	6.45	L-3	P1	1.75	0.31	0.63	0.25	0.63	1.94	1.31	5.50
1 3V 690 P	6.90	6.85	L-3	P1	1.75	0.31	0.63	0.25	0.63	1.94	1.31	4.90
1 3V 800 P	8.00	7.95	L-3	P1	1.75	0.31	0.63	0.25	0.63	1.94	1.31	6.50
1 3V 1060 P	10.60	10.55	L-3	P1	1.75	0.31	0.63	0.25	0.94	1.94	1.31	7.80
1 3V 1400 Q	14.00	13.95	L-3	Q1	2.69	0.53	0.75	0.28	1.06	2.50	1.75	18.10
1 3V 1900 Q	19.00	18.95	L-3	Q1	2.69	0.53	0.75	0.28	1.06	2.50	1.75	26.30
1 3V 2500 Q	25.00	24.95	L-3	Q1	2.69	0.53	0.75	0.28	1.06	2.50	1.75	38.30

NOTE: Dimensions in inches, weight in pounds. Weights do not include bushings 1 = Solid 2 = Web 3 = Spoked

PLEASE NOTE: Dashes are REQUIRED in place of spaces when ordering or searching on PTplace.com.

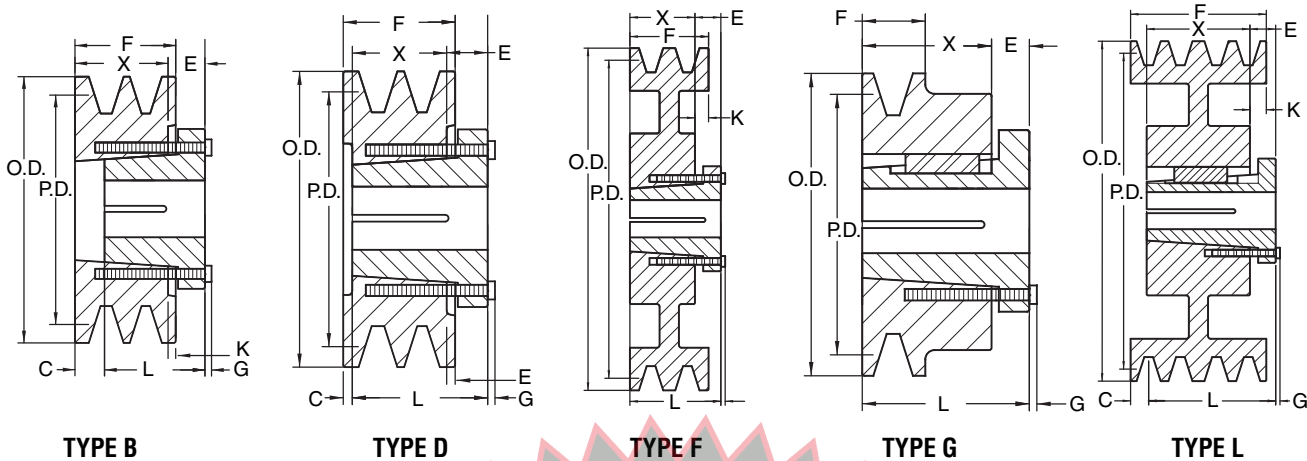

3V MST Sheaves

Nomenclature Example: **2-3V-265-G**

2 Groove												
F = 1-1/32												
Part Number	OD	PD 3V Belt	Type	Bush	Bush Max. Bore	C	E	G	K	Length Thru Bore	X	Wt. Less Bushing
2 3V 265 G	2.65	2.60	B-1	G	1.00	0.41	0.44	0.19	-	1.00	0.97	0.80
2 3V 280 G	2.80	2.75	B-1	G	1.00	0.41	0.44	0.19	-	1.00	0.97	0.90
2 3V 300 G	3.00	2.95	B-1	G	1.00	0.41	0.44	0.19	-	1.00	0.97	1.30
2 3V 315 H	3.15	3.10	D-1	H	1.50	0.22	0.44	0.19	-	1.25	0.81	0.90
2 3V 335 H	3.35	3.30	D-1	H	1.50	0.22	0.44	0.19	-	1.25	0.81	1.30
2 3V 365 H	3.65	3.60	F-1	H	1.50	-	0.44	0.19	0.19	1.25	0.88	1.60
2 3V 365 P	3.65	3.60	G-1	P1	1.75	-	0.63	0.25	-	1.94	1.31	2.00
2 3V 412 H	4.12	4.07	F-1	H	1.50	-	0.44	0.19	0.19	1.25	0.88	2.30
2 3V 412 P	4.12	4.07	G-1	P1	1.75	-	0.63	0.25	-	1.94	1.31	2.80
2 3V 450 H	4.50	4.45	F-1	H	1.50	-	0.44	0.19	0.19	1.25	0.88	2.80
2 3V 450 P	4.50	4.45	G-1	P1	1.75	-	0.63	0.25	-	1.94	1.31	3.50
2 3V 475 H	4.75	4.70	F-1	H	1.50	-	0.44	0.19	0.19	1.25	0.88	3.10
2 3V 475 P	4.75	4.70	G-1	P1	1.75	-	0.63	0.25	-	1.94	1.31	4.00
2 3V 500 H	5.00	4.95	F-1	H	1.50	-	0.44	0.19	0.19	1.25	0.88	3.40
2 3V 500 P	5.00	4.95	G-1	P1	1.75	-	0.63	0.25	-	1.94	1.31	4.60
2 3V 530 H	5.30	5.25	F-1	H	1.50	-	0.44	0.19	0.19	1.25	0.88	3.70
2 3V 530 P	5.30	5.25	G-1	P1	1.75	-	0.63	0.25	-	1.94	1.31	5.60
2 3V 560 H	5.60	5.55	F-1	H	1.50	-	0.44	0.19	0.19	1.25	0.88	3.10
2 3V 560 P	5.60	5.55	G-1	P1	1.75	-	0.63	0.25	-	1.94	1.31	6.00
2 3V 600 H	6.00	5.95	F-1	H	1.50	-	0.44	0.19	0.19	1.25	0.88	3.60
2 3V 600 P	6.00	5.95	G-1	P1	1.75	-	0.63	0.25	-	1.94	1.31	6.80
2 3V 650 P	6.50	6.45	L-3	P1	1.75	0.33	0.75	0.28	1.05	2.50	1.75	8.30
2 3V 690 P	6.90	6.85	L-3	P1	1.75	0.33	0.75	0.28	1.05	2.50	1.75	9.80
2 3V 800 P	8.00	7.95	L-3	Q1	2.69	0.33	0.75	0.28	1.05	2.50	1.75	10.80
2 3V 1060 P	10.60	10.55	L-3	Q1	2.69	0.33	0.75	0.28	1.05	2.50	1.75	13.50
2 3V 1400 Q	14.00	13.95	L-3	Q1	2.69	0.53	0.75	0.28	1.06	2.50	1.75	22.50
2 3V 1900 Q	19.00	18.95	L-3	Q1	2.69	0.53	0.75	0.28	1.06	2.50	1.75	28.90
2 3V 2500 Q	25.00	24.95	L-3	Q1	2.69	0.53	0.75	0.28	1.06	2.50	1.75	43.50

NOTE: Dimensions in inches, weight in pounds. Weights do not include bushings

1 = Solid

2 = Web

3 = Spoked

PLEASE NOTE: Dashes are REQUIRED in place of spaces when ordering or searching on PTplace.com.

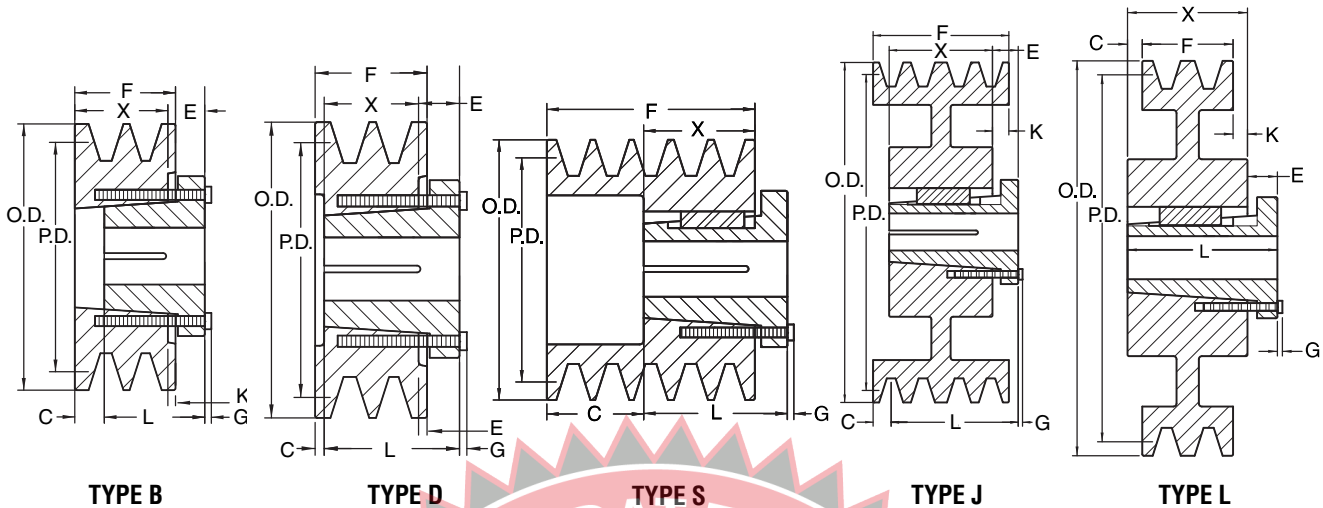

3V MST Sheaves

Nomenclature Example: 3-3V-265-G

3 Groove												
F = 1-1/2												
Part Number	OD	PD 3V Belt	Type	Bush	Bush Max. Bore	C	E	G	K	Length Thru Bore	X	Wt. Less Bushing
3 3V 265 G	2.65	2.60	B-1	G	1.00	0.81	0.44	0.19	0.06	1.00	0.63	1.10
3 3V 280 G	2.80	2.75	B-1	G	1.00	0.81	0.44	0.19	0.06	1.00	0.63	1.60
3 3V 300 G	3.00	2.95	B-1	G	1.00	0.81	0.44	0.19	0.06	1.00	0.63	1.80
3 3V 315 H	3.15	3.10	D-1	H	1.50	0.56	0.44	0.19	0.06	1.25	0.88	1.40
3 3V 335 H	3.35	3.30	D-1	H	1.50	0.56	0.44	0.19	0.06	1.25	0.88	1.80
3 3V 365 P	3.65	3.60	S-1	P1	1.75	0.19	0.63	0.25	0.00	1.94	1.31	2.50
3 3V 412 P	4.12	4.07	S-1	P1	1.75	0.19	0.63	0.25	0.00	1.94	1.31	3.00
3 3V 450 P	4.50	4.45	J-1	P1	1.75	-	0.63	0.25	0.19	1.94	1.31	3.90
3 3V 475 P	4.75	4.70	J-1	P1	1.75	-	0.63	0.25	0.19	1.94	1.31	4.40
3 3V 500 P	5.00	4.95	J-1	P1	1.75	-	0.63	0.25	0.19	1.94	1.31	4.90
3 3V 530 P	5.30	5.25	J-1	P1	1.75	-	0.63	0.25	0.19	1.94	1.31	5.90
3 3V 560 P	5.60	5.55	J-1	P1	1.75	-	0.63	0.25	0.19	1.94	1.31	7.50
3 3V 600 P	6.00	5.95	J-1	P1	1.75	-	0.63	0.25	0.19	1.94	1.31	8.00
3 3V 650 Q	6.50	6.45	L-1	Q1	2.69	0.13	0.75	0.28	0.38	2.50	1.75	9.90
3 3V 690 Q	6.90	6.85	L-1	Q1	2.69	0.13	0.75	0.28	0.38	2.50	1.75	11.30
3 3V 800 Q	8.00	7.95	L-2	Q1	2.69	0.13	0.75	0.28	0.38	2.50	1.75	11.90
3 3V 1060 Q	10.60	10.55	L-3	Q1	2.69	0.13	0.75	0.28	0.38	2.50	1.75	15.10
3 3V 1400 Q	14.00	13.95	L-3	Q1	2.69	0.13	0.75	0.28	0.38	2.50	1.75	24.50
3 3V 1900 R	19.00	18.95	L-3	R1	3.75	0.25	0.88	0.28	0.75	2.88	2.00	35.10
3 3V 2500 R	25.00	24.95	L-3	R1	3.75	0.25	0.88	0.28	0.75	2.88	2.00	55.00
3 3V 3350 R	33.50	33.45	L-3	R1	3.75	0.25	0.88	0.28	0.75	2.88	2.00	80.00

NOTE: Dimensions in inches, weight in pounds. Weights do not include bushings 1 = Solid 2 = Web 3 = Spoked

PLEASE NOTE: Dashes are REQUIRED in place of spaces when ordering or searching on PTplace.com.

V-Belt | MST® Sheaves

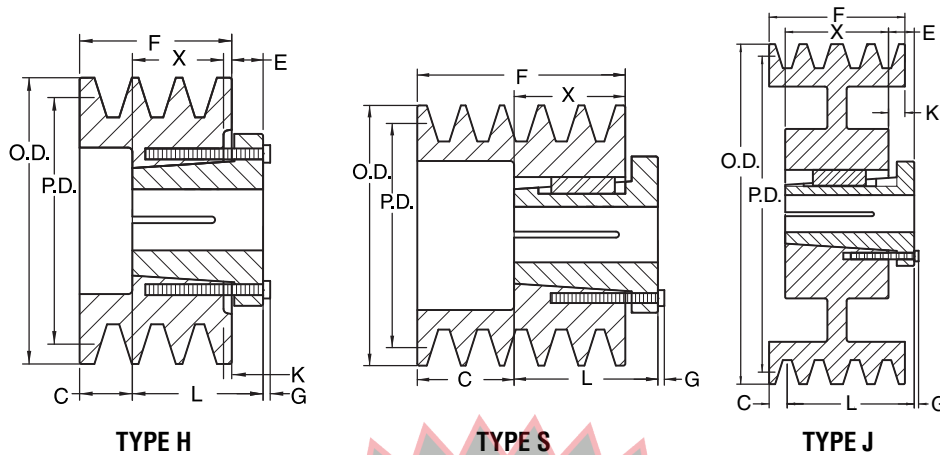

3V MST Sheaves

Nomenclature Example: **4-3V-265-G**

4 Groove												
F = 1-29/32												
Part Number	OD	PD	Type	Bush	Bush Max. Bore	C	E	G	K	Length Thru Bore	X	Wt. Less Bushing
		3V Belt										
4 3V 265 G	2.65	2.60	H-1	G	1.00	1.22	0.44	0.19	0.06	1.00	0.63	1.40
4 3V 280 G	2.80	2.75	H-1	G	1.00	1.22	0.44	0.19	0.06	1.00	0.63	1.80
4 3V 300 G	3.00	2.95	H-1	G	1.00	1.22	0.44	0.19	0.06	1.00	0.63	2.10
4 3V 315 H	3.15	3.10	H-1	H	1.50	0.97	0.44	0.19	0.06	1.25	0.88	1.80
4 3V 335 H	3.35	3.30	H-1	H	1.50	0.97	0.44	0.19	0.06	1.25	0.88	2.30
4 3V 365 P	3.65	3.60	S-1	P1	1.75	0.59	0.63	0.25	0.00	1.94	1.31	2.80
4 3V 412 P	4.12	4.07	S-1	P1	1.75	0.59	0.63	0.25	0.00	1.94	1.31	3.70
4 3V 450 P	4.50	4.45	J-1	P1	1.75	-	0.63	0.25	0.59	1.94	1.31	4.40
4 3V 475 P	4.75	4.70	J-1	P1	1.75	-	0.63	0.25	0.59	1.94	1.31	5.10
4 3V 500 P	5.00	4.95	J-1	P1	1.75	-	0.63	0.25	0.59	1.94	1.31	5.80
4 3V 530 P	5.30	5.25	J-1	P1	1.75	-	0.63	0.25	0.59	1.94	1.31	6.50
4 3V 560 P	5.60	5.55	J-1	P1	1.75	-	0.63	0.25	0.59	1.94	1.31	8.10
4 3V 600 Q	6.00	5.95	J-1	Q1	2.69	-	0.75	0.28	0.16	2.50	1.75	9.00
4 3V 650 Q	6.50	6.45	J-2	Q1	2.69	0.08	0.75	0.28	0.08	2.50	1.75	11.10
4 3V 690 Q	6.90	6.85	J-2	Q1	2.69	0.08	0.75	0.28	0.08	2.50	1.75	12.90
4 3V 800 Q	8.00	7.95	J-2	Q1	2.69	0.08	0.75	0.28	0.08	2.50	1.75	13.10
4 3V 1060 Q	10.60	10.55	J-3	Q1	2.69	0.08	0.75	0.28	0.08	2.50	1.75	15.90
4 3V 1400 Q	14.00	13.95	J-3	Q1	2.69	0.08	0.75	0.28	0.08	2.50	1.75	25.40
4 3V 1900 R	19.00	18.95	J-3	R1	3.75	0.05	0.88	0.28	0.14	2.88	2.00	37.30
4 3V 2500 R	25.00	24.95	J-3	R1	3.75	0.05	0.88	0.28	0.14	2.88	2.00	60.00
4 3V 3350 R	33.50	33.45	J-3	R1	3.75	0.05	0.88	0.28	0.14	2.88	2.00	88.00

NOTE: Dimensions in inches, weight in pounds. Weights do not include bushings 1 = Solid 2 = Web 3 = Spoked

PLEASE NOTE: Dashes are REQUIRED in place of spaces when ordering or searching on PTplace.com.

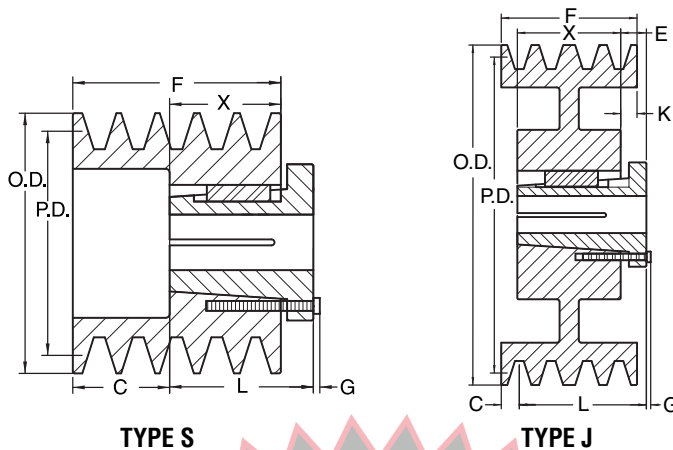

3V MST Sheaves

Nomenclature Example: 5-3V-475-P

5 Groove												
F = 2-5/16												
Part Number	OD	PD 3V Belt	Type	Bush	Bush Max. Bore	C	E	G	K	Length Thru Bore	X	Wt. Less Bushing
5 3V 475 P	4.75	4.70	J-2	P1	1.75	0.38	0.63	0.25	0.62	1.94	1.31	5.60
5 3V 500 P	5.00	4.95	J-2	P1	1.75	0.38	0.63	0.25	0.62	1.94	1.31	6.00
5 3V 530 P	5.30	5.25	J-2	P1	1.75	0.38	0.63	0.25	0.62	1.94	1.31	7.10
5 3V 560 P	5.60	5.55	J-2	P1	1.75	0.38	0.63	0.25	0.62	1.94	1.31	8.10
5 3V 600 Q	6.00	5.95	J-2	Q1	2.69	0.00	0.75	0.28	0.56	2.50	1.75	9.50
5 3V 650 Q	6.50	6.45	J-2	Q1	2.69	0.28	0.75	0.28	0.28	2.50	1.75	11.60
5 3V 690 Q	6.90	6.85	J-2	Q1	2.69	0.28	0.75	0.28	0.28	2.50	1.75	13.90
5 3V 800 Q	8.00	7.95	J-2	Q1	2.69	0.28	0.75	0.28	0.28	2.50	1.75	14.30
5 3V 1060 Q	10.60	10.55	J-3	Q1	2.69	0.28	0.75	0.28	0.28	2.50	1.75	17.50
5 3V 1400 Q	14.00	13.95	J-3	Q1	2.69	0.28	0.75	0.28	0.28	2.50	1.75	27.50
5 3V 1900 R	19.00	18.95	J-3	R1	3.75	0.16	0.88	0.28	0.16	2.88	2.00	40.90
5 3V 2500 R	25.00	24.95	J-3	R1	3.75	0.16	0.88	0.28	0.16	2.88	2.00	64.00
5 3V 3350 R	33.50	33.45	J-3	R1	3.75	0.16	0.88	0.28	0.16	2.88	2.00	92.00
6 Groove												
F = 2-23/32												
Part Number	OD	PD 3V Belt	Type	Bush	Bush Max. Bore	C	E	G	K	Length Thru Bore	X	Wt. Less Bushing
6 3V 475 Q	4.75	4.70	S-1	Q1	2.69	0.97	-	0.28	-	2.50	1.75	5.60
6 3V 500 Q	5.00	4.95	S-1	Q1	2.69	0.97	-	0.28	-	2.50	1.75	6.10
6 3V 530 Q	5.30	5.25	S-1	Q1	2.69	0.97	-	0.28	-	2.50	1.75	7.30
6 3V 560 Q	5.60	5.55	J-1	Q1	2.69	0.22	0.75	0.28	0.75	2.50	1.75	8.80
6 3V 600 Q	6.00	5.95	J-2	Q1	2.69	0.22	0.75	0.28	0.75	2.50	1.75	10.10
6 3V 650 Q	6.50	6.45	J-2	Q1	2.69	0.48	0.75	0.28	0.48	2.50	1.75	12.90
6 3V 690 Q	6.90	6.85	J-2	Q1	2.69	0.48	0.75	0.28	0.48	2.50	1.75	14.40
6 3V 800 Q	8.00	7.95	J-2	Q1	2.69	0.48	0.75	0.28	0.48	2.50	1.75	16.10
6 3V 1060 R	10.60	10.55	J-3	R1	3.75	0.36	0.88	0.28	0.36	2.88	2.00	22.40
6 3V 1400 R	14.00	13.95	J-3	R1	3.75	0.36	0.88	0.28	0.36	2.88	2.00	32.10
6 3V 1900 R	19.00	18.95	J-3	R1	3.75	0.36	0.88	0.28	0.36	2.88	2.00	42.80
6 3V 2500 R	25.00	24.95	J-3	R1	3.75	0.36	0.88	0.28	0.36	2.88	2.00	64.00
6 3V 3350 R	33.50	33.45	J-3	R1	3.75	0.36	0.88	0.28	0.36	2.88	2.00	99.00

NOTE: Dimensions in inches, weight in pounds. Weights do not include bushings 1 = Solid 2 = Web 3 = Spoked

PLEASE NOTE: Dashes are REQUIRED in place of spaces when ordering or searching on PTplace.com.

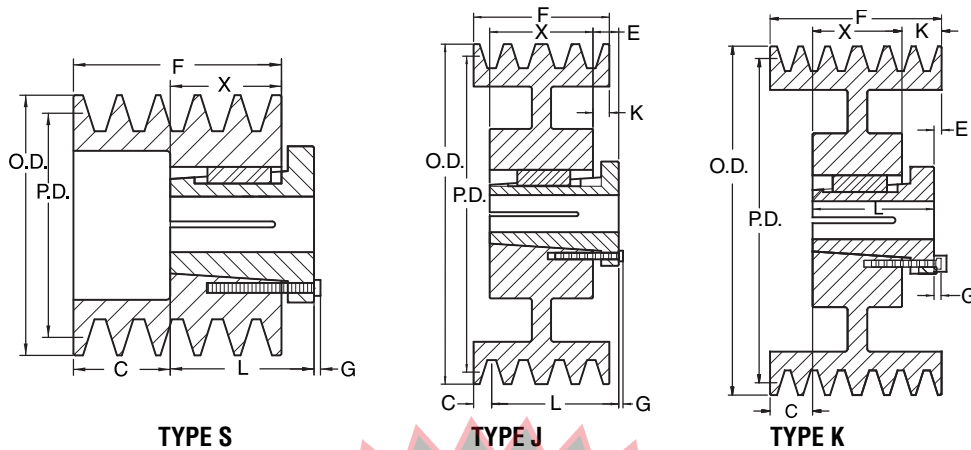

3V MST Sheaves

Nomenclature Example: **8-3V-475-Q**

8 Groove												
F = 3-17/32												
Part Number	OD	PD	Type	Bush	Bush Max. Bore	C	E	G	K	Length Thru Bore	X	Wt. Less Bushing
		3V Belt										
8 3V 475 Q	4.75	4.70	S-1	Q2	2.63	0.78	0.75	0.28	-	3.50	2.75	7.30
8 3V 500 Q	5.00	4.95	S-1	Q2	2.63	0.78	0.75	0.28	-	3.50	2.75	8.60
8 3V 530 Q	5.30	5.25	S-1	Q2	2.63	0.78	0.75	0.28	-	3.50	2.75	10.30
8 3V 560 Q	5.60	5.55	K-1	Q2	2.63	-	0.75	0.28	0.78	3.50	2.75	12.30
8 3V 600 Q	6.00	5.95	K-1	Q2	2.63	-	0.75	0.28	0.78	3.50	2.75	15.10
8 3V 650 Q	6.50	6.45	J-2	Q2	2.63	0.39	0.75	0.28	0.39	3.50	2.75	18.30
8 3V 690 Q	6.90	6.85	J-2	Q2	2.63	0.39	0.75	0.28	0.39	3.50	2.75	21.40
8 3V 800 R	8.00	7.95	J-2	R1	3.75	0.77	0.88	0.28	0.77	2.88	2.00	23.20
8 3V 1060 R	10.60	10.55	J-3	R1	3.75	0.77	0.88	0.28	0.77	2.88	2.00	24.50
8 3V 1400 R	14.00	13.95	J-3	R1	3.75	0.77	0.88	0.28	0.77	2.88	2.00	39.00
8 3V 1900 R	19.00	18.95	J-3	R1	3.75	0.77	0.88	0.28	0.77	2.88	2.00	49.00
8 3V 2500 R	25.00	24.95	J-3	R1	3.75	0.77	0.88	0.28	0.77	2.88	2.00	76.00
8 3V 3350 S	33.50	33.45	J-3	S1	4.25	0.11	1.06	0.38	0.11	4.38	3.31	126.00
10 Groove												
F = 4-11/32												
Part Number	OD	PD	Type	Bush	Bush Max. Bore	C	E	G	K	Length Thru Bore	X	Wt. Less Bushing
		3V Belt										
10 3V 475 Q	4.75	4.70	S-1	Q2	2.63	1.59	0.75	0.28	-	3.50	2.75	8.40
10 3V 500 Q	5.00	4.95	S-1	Q2	2.63	1.59	0.75	0.28	-	3.50	2.75	9.90
10 3V 530 Q	5.30	5.25	S-1	Q2	2.63	1.59	0.75	0.28	-	3.50	2.75	11.40
10 3V 560 Q	5.60	5.55	J-2	Q2	2.63	0.84	0.75	0.28	0.75	3.50	2.75	13.80
10 3V 600 Q	6.00	5.95	J-2	Q2	2.63	0.84	0.75	0.28	0.75	3.50	2.75	16.50
10 3V 650 Q	6.50	6.45	K-2	Q2	2.63	0.80	0.75	0.28	0.80	3.50	2.75	20.40
10 3V 690 Q	6.90	6.85	K-2	Q2	2.63	0.80	0.75	0.28	0.80	3.50	2.75	23.40
10 3V 800 R	8.00	7.95	K-2	R1	3.75	1.17	0.88	0.28	1.17	2.88	2.00	26.00
10 3V 1060 R	10.60	10.55	K-3	R1	3.75	1.17	0.88	0.28	1.17	2.88	2.00	28.40
10 3V 1400 R	14.00	13.95	K-3	R1	3.75	1.17	0.88	0.28	1.17	2.88	2.00	42.30
10 3V 1900 R	19.00	18.95	K-3	R1	3.75	1.17	0.88	0.28	1.17	2.88	2.00	54.00
10 3V 2500 S	25.00	24.95	J-3	S1	4.25	0.52	1.06	0.38	0.52	4.38	3.31	103.00
10 3V 3350 S	33.50	33.45	J-3	S1	4.25	0.52	1.06	0.38	0.52	4.38	3.31	138.00

NOTE: Dimensions in inches, weight in pounds. Weights do not include bushings

1 = Solid

2 = Web

3 = Spoked

PLEASE NOTE: Dashes are REQUIRED in place of spaces when ordering or searching on PTplace.com.

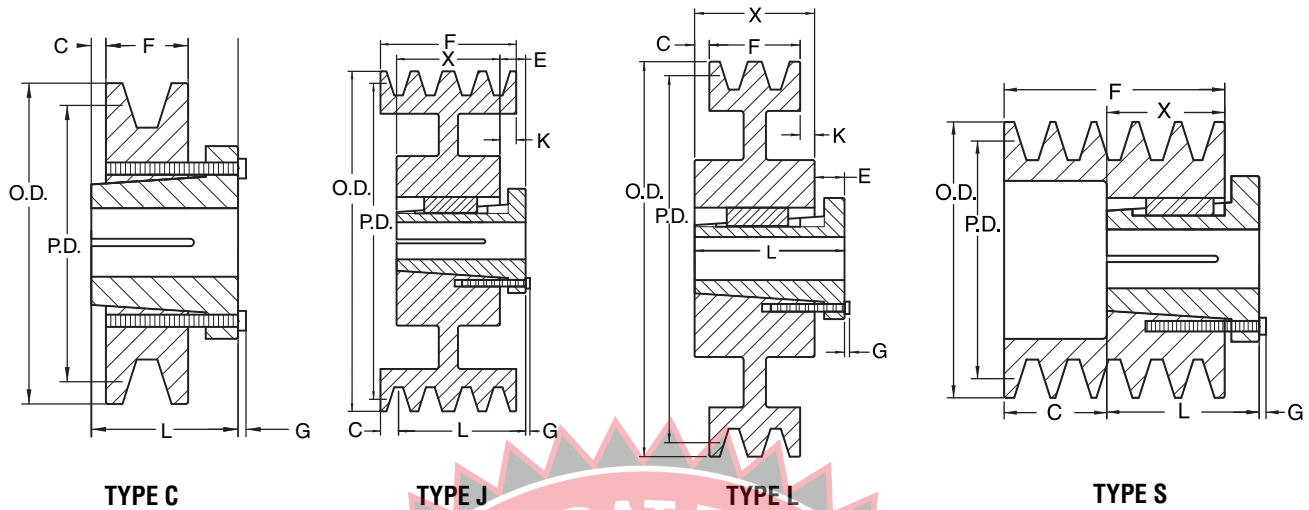

5V MST Sheaves

Nomenclature Example: 2-5V-440-P

2 Groove F = 1-11/16												
Part Number	OD	PD 5V Belt	Type	Bush	Bush Max. Bore	C	E	G	K	Length Thru Bore	X	Wt. Less Bushing
2 5V 440 P	4.40	4.30	J-1	P1	1.75	0.19	0.63	0.25	—	1.94	1.31	3.80
2 5V 460 Q	4.60	4.50	C-1	Q1	2.69	—	0.75	0.28	—	2.50	1.75	6.60
2 5V 490 Q	4.90	4.80	C-1	Q1	2.69	—	0.75	0.28	—	2.50	1.75	6.20
2 5V 520 Q	5.20	5.10	C-1	Q1	2.69	—	0.75	0.28	—	2.50	1.75	5.60
2 5V 550 Q	5.50	5.40	C-1	Q1	2.69	—	0.75	0.28	—	2.50	1.75	6.60
2 5V 590 Q	5.90	5.80	C-1	Q1	2.69	—	0.75	0.28	—	2.50	1.75	7.60
2 5V 630 Q	6.30	6.20	C-1	Q1	2.69	—	0.75	0.28	—	2.50	1.75	9.40
2 5V 670 Q	6.70	6.60	C-1	Q1	2.69	—	0.75	0.28	—	2.50	1.75	11.00
2 5V 710 Q	7.10	7.00	C-1	Q1	2.69	—	0.75	0.28	—	2.50	1.75	11.60
2 5V 750 Q	7.50	7.40	C-1	Q1	2.69	—	0.75	0.28	—	2.50	1.75	14.10
2 5V 800 Q	8.00	7.90	C-1	Q1	2.69	—	0.75	0.28	—	2.50	1.75	11.60
2 5V 850 Q	8.50	8.40	L-2	Q1	2.69	—	0.75	0.28	—	2.50	1.75	12.90
2 5V 900 Q	9.00	8.90	L-2	Q1	2.69	0.03	0.75	0.28	0.03	2.50	1.75	16.30
2 5V 925 Q	9.25	9.15	L-2	Q1	2.69	0.03	0.75	0.28	0.03	2.50	1.75	15.10
2 5V 975 Q	9.75	9.65	L-2	Q1	2.69	0.03	0.75	0.28	0.03	2.50	1.75	16.10
2 5V 1030 Q	10.30	10.20	L-2	Q1	2.69	0.03	0.75	0.28	0.03	2.50	1.75	18.80
2 5V 1090 Q	10.90	10.80	L-2	Q1	2.69	0.03	0.75	0.28	0.03	2.50	1.75	19.30
2 5V 1180 Q	11.80	11.70	L-2	Q1	2.69	0.03	0.75	0.28	0.03	2.50	1.75	21.40
2 5V 1250 Q	12.50	12.40	L-2	Q1	2.69	0.03	0.75	0.28	0.03	2.50	1.75	23.80
2 5V 1320 Q	13.20	13.10	L-2	Q1	2.69	0.03	0.75	0.28	0.03	2.50	1.75	25.50
2 5V 1400 R	14.00	13.90	L-3	R1	3.75	0.16	0.88	0.28	0.16	2.88	2.00	27.60
2 5V 1500 R	15.00	14.90	L-3	R1	3.75	0.16	0.88	0.28	0.16	2.88	2.00	30.90
2 5V 1600 R	16.00	15.90	L-3	R1	3.75	0.16	0.88	0.28	0.16	2.88	2.00	33.30
2 5V 2120 R	21.20	21.10	L-3	R1	3.75	0.16	0.88	0.28	0.16	2.88	2.00	47.50
2 5V 2800 R	28.00	27.90	L-3	R1	3.75	0.16	0.88	0.28	0.16	2.88	2.00	71.00

NOTE: Dimensions in inches, weight in pounds. Weights do not include bushings 1 = Solid 2 = Web 3 = Spoked

PLEASE NOTE: Dashes are REQUIRED in place of spaces when ordering or searching on PTplace.com.

V-Belt | MST® Sheaves

5V MST Sheaves

Nomenclature Example: **3-5V-440-P**

3 Groove												
F = 2-3/8												
Part Number	OD	PD	Type	Bush	Bush Max. Bore	C	E	G	K	Length Thru Bore	X	Wt. Less Bushing
		5V Belt										
3 5V 440 P	4.40	4.30	S-1	P1	1.75	0.53	0.63	0.25	0.53	1.94	1.31	3.10
3 5V 460 Q	4.60	4.50	S-1	Q1	2.69	1.78	0.75	0.28	1.16	2.50	1.75	7.60
3 5V 490 Q	4.90	4.80	S-1	Q1	2.69	0.63	0.75	0.28	0.00	2.50	1.75	7.30
3 5V 520 Q	5.20	5.10	J-1	Q1	2.69	0.63	0.75	0.28	0.00	2.50	1.75	5.80
3 5V 550 Q	5.50	5.40	J-1	Q1	2.69	0.63	0.75	0.28	0.00	2.50	1.75	7.50
3 5V 590 Q	5.90	5.80	J-1	Q1	2.69	0.19	0.75	0.28	0.44	2.50	1.75	8.60
3 5V 630 Q	6.30	6.20	J-1	Q1	2.69	0.19	0.75	0.28	0.44	2.50	1.75	10.30
3 5V 670 Q	6.70	6.60	J-2	Q1	2.69	0.19	0.75	0.28	0.44	2.50	1.75	12.00
3 5V 710 Q	7.10	7.00	J-2	Q1	2.69	0.19	0.75	0.28	0.44	2.50	1.75	13.90
3 5V 750 Q	7.50	7.40	J-2	Q1	2.69	0.19	0.75	0.28	0.44	2.50	1.75	16.00
3 5V 800 R	8.00	7.90	J-1	R1	3.75	0.19	0.88	0.28	0.19	2.88	2.00	17.20
3 5V 850 R	8.50	8.40	J-1	R1	3.75	0.19	0.88	0.28	0.19	2.88	2.00	20.50
3 5V 900 R	9.00	8.90	J-1	R1	3.75	0.19	0.88	0.28	0.19	2.88	2.00	22.20
3 5V 925 R	9.25	9.15	L-3	R1	3.75	0.19	0.88	0.28	0.19	2.88	2.00	24.10
3 5V 975 R	9.75	9.65	L-3	R1	3.75	0.19	0.88	0.28	0.19	2.88	2.00	24.80
3 5V 1030 R	10.30	10.20	J-2	R1	3.75	0.19	0.88	0.28	0.19	2.88	2.00	26.40
3 5V 1090 R	10.90	10.80	J-3	R1	3.75	0.19	0.88	0.28	0.19	2.88	2.00	28.00
3 5V 1180 R	11.80	11.70	J-3	R1	3.75	0.19	0.88	0.28	0.19	2.88	2.00	31.90
3 5V 1250 R	12.50	12.40	J-3	R1	3.75	0.19	0.88	0.28	0.19	2.88	2.00	35.10
3 5V 1320 R	13.20	13.10	J-3	R1	3.75	0.19	0.88	0.28	0.19	2.88	2.00	29.00
3 5V 1400 R	14.00	13.90	J-3	R1	3.75	0.19	0.88	0.28	0.19	2.88	2.00	32.30
3 5V 1500 R	15.00	14.90	J-3	R1	3.75	0.19	0.88	0.28	0.19	2.88	2.00	35.00
3 5V 1600 R	16.00	15.90	J-3	R1	3.75	0.19	0.88	0.28	0.19	2.88	2.00	38.70
3 5V 2120 R	21.20	21.10	J-3	R1	3.75	0.19	0.88	0.28	0.19	2.88	2.00	52.00
3 5V 2800 R	28.00	27.90	J-3	R1	3.75	0.19	0.88	0.28	0.19	2.88	2.00	80.00
3 5V 3750 S	37.50	37.40	L-3	S1	4.25	0.19	1.06	0.38	1.13	4.38	3.31	147.00
3 5V 5000 U	50.00	49.90	L-3	U0	5.50	0.69	1.19	0.47	2.06	4.94	3.75	216.00

4 Groove												
F = 3-1/16												
Part Number	OD	PD	Type	Bush	Bush Max. Bore	C	E	G	K	Length Thru Bore	X	Wt. Less Bushing
		5V Belt										
4 5V 440 P	4.40	4.30	S-1	P1	1.75	0.88	0.63	0.25	0.87	1.94	1.31	3.20
4 5V 465 Q	4.60	4.50	S-1	Q2	2.63	1.47	0.75	0.28	1.16	3.50	2.75	8.60
4 5V 490 Q	4.90	4.80	S-1	Q1	2.69	1.31	0.75	0.28	-	2.50	1.75	8.50
4 5V 520 Q	5.20	5.10	J-1	Q1	2.69	1.31	0.75	0.28	-	2.50	1.75	7.80
4 5V 550 Q	5.50	5.40	J-1	Q1	2.69	1.31	0.75	0.28	-	2.50	1.75	8.30
4 5V 590 Q	5.90	5.80	J-1	Q1	2.69	0.56	0.75	0.28	0.75	2.50	1.75	10.10
4 5V 630 Q	6.30	6.20	J-2	Q1	2.69	0.56	0.75	0.28	0.75	2.50	1.75	11.80
4 5V 670 Q	6.70	6.60	J-2	Q1	2.69	0.56	0.75	0.28	0.75	2.50	1.75	13.60
4 5V 710 Q	7.10	7.00	J-2	Q1	2.69	0.56	0.75	0.28	0.75	2.50	1.75	15.90
4 5V 750 Q	7.50	7.40	J-2	Q1	2.69	0.56	0.75	0.28	0.75	2.50	1.75	18.40
4 5V 800 R	8.00	7.90	J-1	R1	3.75	0.53	0.88	0.28	0.53	2.88	2.00	19.40
4 5V 850 R	8.50	8.40	J-1	R1	3.75	0.53	0.88	0.28	0.53	2.88	2.00	22.80
4 5V 900 R	9.00	8.90	J-2	R1	3.75	0.53	0.88	0.28	0.53	2.88	2.00	24.50
4 5V 925 R	9.25	9.15	J-2	R1	3.75	0.53	0.88	0.28	0.53	2.88	2.00	26.60
4 5V 975 R	9.75	9.65	J-2	R1	3.75	0.53	0.88	0.28	0.53	2.88	2.00	28.00
4 5V 1030 R	10.30	10.20	J-2	R1	3.75	0.53	0.88	0.28	0.53	2.88	2.00	30.80
4 5V 1090 R	10.90	10.80	J-2	R1	3.75	0.53	0.88	0.28	0.53	2.88	2.00	31.70
4 5V 1180 R	11.80	11.70	J-3	R1	3.75	0.53	0.88	0.28	0.53	2.88	2.00	35.30
4 5V 1250 R	12.50	12.40	J-3	R1	3.75	0.53	0.88	0.28	0.53	2.88	2.00	37.90
4 5V 1320 R	13.20	13.10	J-3	R1	3.75	0.53	0.88	0.28	0.53	2.88	2.00	33.30
4 5V 1400 R	14.00	13.90	J-3	R1	3.75	0.53	0.88	0.28	0.53	2.88	2.00	36.50
4 5V 1500 R	15.00	14.90	J-3	R1	3.75	0.53	0.88	0.28	0.53	2.88	2.00	40.90
4 5V 1600 R	16.00	15.90	J-3	R1	3.75	0.53	0.88	0.28	0.53	2.88	2.00	43.30
4 5V 2120 R	21.20	21.10	J-3	R1	3.75	0.53	0.88	0.28	0.53	2.88	2.00	59.00
4 5V 2800 S	28.00	27.90	L-3	S1	4.25	0.13	1.06	0.38	0.38	4.38	3.31	135.00
4 5V 3750 S	37.50	37.40	L-3	S1	4.25	0.13	1.06	0.38	0.38	4.38	3.31	157.00
4 5V 5000 Q	50.00	49.90	L-3	Q1	2.69	0.34	0.75	0.28	0.97	2.50	1.75	239.00

NOTE: Dimensions in inches, weight in pounds. Weights do not include bushings

1 = Solid

2 = Web

3 = Spoked

PLEASE NOTE: Dashes are REQUIRED in place of spaces when ordering or searching on PTplace.com.

5V MST Sheaves

Nomenclature Example: 5-5V-465-Q

5 Groove												
F = 3-3/4												
Part Number	OD	PD	Type	Bush	Bush Max. Bore	C	E	G	K	Length Thru Bore	X	Wt. Less Bushing
		5V Belt										
5 5V 465 Q	4.60	4.50	S-1	Q2	2.63	2.31	0.75	0.28	1.31	3.50	2.75	8.90
5 5V 490 Q	4.90	4.80	S-1	Q2	2.63	1.00	0.75	0.28	0.00	3.50	2.75	9.20
5 5V 520 Q	5.20	5.10	J-1	Q2	2.63	1.00	0.75	0.28	0.00	3.50	2.75	9.00
5 5V 550 Q	5.50	5.40	J-1	Q2	2.63	1.00	0.75	0.28	0.00	3.50	2.75	10.80
5 5V 590 Q	5.90	5.80	J-1	Q2	2.63	0.25	0.75	0.28	0.75	3.50	2.75	13.20
5 5V 630 Q	6.30	6.20	J-2	Q2	2.63	0.25	0.75	0.28	0.75	3.50	2.75	15.90
5 5V 670 Q	6.70	6.60	J-2	Q2	2.63	0.25	0.75	0.28	0.75	3.50	2.75	18.60
5 5V 710 Q	7.10	7.00	K-2	Q2	2.63	0.25	0.75	0.28	0.75	3.50	2.75	22.00
5 5V 750 Q	7.50	7.40	K-1	Q2	2.63	0.25	0.75	0.28	0.75	3.50	2.75	25.00
5 5V 800 R	8.00	7.90	K-1	R1	3.75	0.88	0.88	0.28	0.88	2.88	2.00	21.70
5 5V 850 R	8.50	8.40	J-1	R1	3.75	0.88	0.88	0.28	0.88	2.88	2.00	25.10
5 5V 900 R	9.00	8.90	J-1	R1	3.75	0.88	0.88	0.28	0.88	2.88	2.00	25.40
5 5V 925 R	9.25	9.15	J-3	R1	3.75	0.88	0.88	0.28	0.88	2.88	2.00	28.40
5 5V 975 R	9.75	9.65	J-3	R1	3.75	0.88	0.88	0.28	0.88	2.88	2.00	31.80
5 5V 1030 R	10.30	10.20	J-2	R1	3.75	0.88	0.88	0.28	0.88	2.88	2.00	32.50
5 5V 1090 R	10.90	10.80	K-2	R1	3.75	0.88	0.88	0.28	0.88	2.88	2.00	35.10
5 5V 1180 R	11.80	11.70	J-2	R1	3.75	0.88	0.88	0.28	0.88	2.88	2.00	38.80
5 5V 1250 R	12.50	12.40	J-2	R1	3.75	0.88	0.88	0.28	0.88	2.88	2.00	41.80
5 5V 1320 R	13.20	13.10	K-3	R1	3.75	0.88	0.88	0.28	0.88	2.88	2.00	37.10
5 5V 1400 R	14.00	13.90	K-3	R1	3.75	0.88	0.88	0.28	0.88	2.88	2.00	41.60
5 5V 1500 R	15.00	14.90	K-3	R1	3.75	0.88	0.88	0.28	0.88	2.88	2.00	45.00
5 5V 1600 R	16.00	15.90	K-3	R1	3.75	0.88	0.88	0.28	0.88	2.88	2.00	48.00
5 5V 2120 S	21.20	21.10	J-3	S1	4.25	0.22	1.06	0.38	0.22	4.38	3.31	90.00
5 5V 2500 S	25.00	24.90	J-3	S1	4.25	0.22	1.06	0.38	0.22	4.38	3.31	105.00
5 5V 2800 S	28.00	27.90	J-3	S1	4.25	0.22	1.06	0.38	0.22	4.38	3.31	120.00
5 5V 3750 U	37.50	37.40	K-2	U0	5.50	0.00	1.19	0.47	0.00	4.94	3.75	185.00
5 5V 5000 U	50.00	49.90	J-1	U0	5.50	0.00	1.19	0.47	0.00	4.94	3.75	244.00

6 Groove												
F = 4-7/16												
Part Number	OD	PD	Type	Bush	Bush Max. Bore	C	E	G	K	Length Thru Bore	X	Wt. Less Bushing
		5V Belt										
6 5V 710 Q	7.10	7.00	J-2	Q2	2.63	0.44	0.28	0.75	1.25	3.50	2.75	23.60
6 5V 750 Q	7.50	7.40	J-2	Q2	2.63	0.44	0.28	0.75	1.25	3.50	2.75	27.30
6 5V 800 R	8.00	7.90	K-2	R1	3.75	1.22	0.28	0.88	1.22	2.88	2.00	23.30
6 5V 850 R	8.50	8.40	K-2	R1	3.75	1.22	0.28	0.88	1.22	2.88	2.00	27.30
6 5V 900 R	9.00	8.90	K-2	R1	3.75	1.22	0.28	0.88	1.22	2.88	2.00	28.80
6 5V 925 R	9.25	9.15	J-1	R1	3.75	1.22	0.28	0.88	1.22	2.88	2.00	31.10
6 5V 975 R	9.75	9.65	J-3	R1	3.75	1.22	0.28	0.88	1.22	2.88	2.00	34.50
6 5V 1030 R	10.30	10.20	K-2	R1	3.75	1.22	0.28	0.88	1.22	2.88	2.00	36.80
6 5V 1090 R	10.90	10.80	J-1	R1	3.75	1.22	0.28	0.88	1.22	2.88	2.00	39.60
6 5V 1180 R	11.80	11.70	J-1	R1	3.75	1.22	0.28	0.88	1.22	2.88	2.00	42.50
6 5V 1250 S	12.50	12.40	J-3	S1	4.25	0.56	0.38	1.06	0.56	4.38	3.31	65.00
6 5V 1320 S	13.20	13.10	J-3	S1	4.25	0.56	0.38	1.06	0.56	4.38	3.31	71.00
6 5V 1400 S	14.00	13.90	J-2	S1	4.25	0.56	0.38	1.06	0.56	4.38	3.31	70.00
6 5V 1500 S	15.00	14.90	J-3	S1	4.25	0.56	0.38	1.06	0.56	4.38	3.31	69.00
6 5V 1600 S	16.00	15.90	J-3	S1	4.25	0.56	0.38	1.06	0.56	4.38	3.31	79.00
6 5V 2120 S	21.20	21.10	J-3	S1	4.25	0.56	0.38	1.06	0.56	4.38	3.31	97.00
6 5V 2500 S	25.00	24.90	J-3	S1	4.25	0.56	0.38	1.06	0.56	4.38	3.31	113.00
6 5V 2800 S	28.00	27.90	J-3	S1	4.25	0.56	0.38	1.06	0.56	4.38	3.31	128.00
6 5V 3750 U	37.50	37.40	K-2	U0	5.50	0.34	0.47	1.19	0.34	4.94	3.75	206.00
6 5V 5000 U	50.00	49.90	K-2	U0	5.50	0.34	0.47	1.19	0.34	4.94	3.75	271.00

NOTE: Dimensions in inches, weight in pounds. Weights do not include bushings 1 = Solid 2 = Web 3 = Spoked

PLEASE NOTE: Dashes are REQUIRED in place of spaces when ordering or searching on PTplace.com.

V-Belt | MST® Sheaves

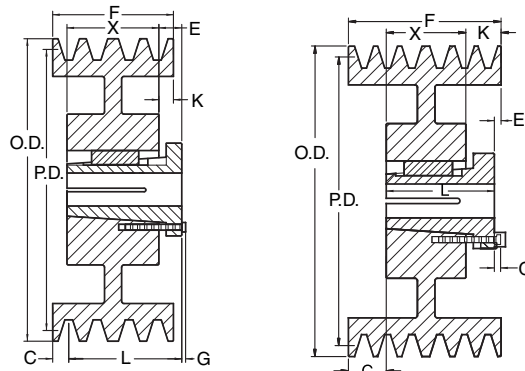

TYPE J

TYPE K

5V MST Sheaves

Nomenclature Example: **8-5V-710-Q**

8 Groove F = 5-13/16												
Part Number	OD	PD	Type	Bush	Bush Max. Bore	C	E	G	K	Length Thru Bore	X	Wt. Less Bushing
		5V Belt										
8 5V 710 Q	7.10	7.00	K-2	Q2	2.63	1.31	0.75	0.28	1.75	3.50	2.75	28.00
8 5V 750 Q	7.50	7.40	K-2	Q2	2.63	1.31	0.75	0.28	1.75	3.50	2.75	32.00
8 5V 800 R	8.00	7.90	K-2	R2	3.63	0.91	0.88	0.28	0.91	4.88	4.00	45.30
8 5V 850 R	8.50	8.40	K-2	R2	3.63	0.91	0.88	0.28	0.91	4.88	4.00	45.50
8 5V 900 R	9.00	8.90	K-2	R2	3.63	0.91	0.88	0.28	0.91	4.88	4.00	50.00
8 5V 925 S	9.25	9.15	K-2	S1	4.25	1.25	1.06	0.38	1.25	4.38	3.31	47.30
8 5V 975 S	9.75	9.65	K-2	S1	4.25	1.25	1.06	0.38	1.25	4.38	3.31	50.00
8 5V 1030 S	10.30	10.20	K-2	S1	4.25	1.25	1.06	0.38	1.25	4.38	3.31	63.00
8 5V 1090 S	10.90	10.80	K-2	S1	4.25	1.25	1.06	0.38	1.25	4.38	3.31	71.00
8 5V 1180 S	11.80	11.70	K-2	S1	4.25	1.25	1.06	0.38	1.25	4.38	3.31	85.00
8 5V 1250 S	12.50	12.40	K-3	S1	4.25	1.25	1.06	0.38	1.25	4.38	3.31	76.00
8 5V 1320 S	13.20	13.10	K-3	S1	4.25	1.25	1.06	0.38	1.25	4.38	3.31	79.00
8 5V 1400 S	14.00	13.90	K-3	S1	4.25	1.25	1.06	0.38	1.25	4.38	3.31	77.00
8 5V 1500 S	15.00	14.90	K-3	S1	4.25	1.25	1.06	0.38	1.25	4.38	3.31	83.00
8 5V 1600 S	16.00	15.90	K-3	S1	4.25	1.25	1.06	0.38	1.25	4.38	3.31	90.00
8 5V 2120 U	21.20	21.10	J-3	U1	5.50	0.09	1.50	0.47	0.09	7.13	5.63	175.00
8 5V 2500 U	25.00	24.90	J-3	U1	5.50	0.09	1.50	0.47	0.09	7.13	5.63	190.00
8 5V 2800 U	28.00	27.90	J-3	U1	5.50	0.09	1.50	0.47	0.09	7.13	5.63	222.00
8 5V 3750 U	37.50	37.40	J-3	U1	5.50	0.09	1.50	0.47	0.09	7.13	5.63	264.00
8 5V 5000 U	50.00	49.90	J-3	U1	5.50	0.09	1.50	0.47	0.09	7.13	5.63	393.00

10 Groove F = 7-5/16												
Part Number	OD	PD	Type	Bush	Bush Max. Bore	C	E	G	K	Length Thru Bore	X	Wt. Less Bushing
		5V Belt										
10 5V 800 R	8.00	7.90	K-2	R2	3.63	1.59	0.88	0.28	1.59	4.88	4.00	43.80
10 5V 850 R	8.50	8.40	K-2	R2	3.63	1.59	0.88	0.28	1.59	4.88	4.00	53.00
10 5V 900 R	9.00	8.90	K-2	R2	3.63	1.59	0.88	0.28	1.59	4.88	4.00	59.00
10 5V 925 S	9.25	9.15	K-2	S1	4.25	1.94	1.06	0.38	1.94	4.38	3.31	53.00
10 5V 975 S	9.75	9.65	K-2	S1	4.25	1.94	1.06	0.38	1.94	4.38	3.31	60.00
10 5V 1030 S	10.30	10.20	K-2	S1	4.25	1.94	1.06	0.38	1.94	4.38	3.31	69.00
10 5V 1090 S	10.90	10.80	K-2	S1	4.25	1.94	1.06	0.38	1.94	4.38	3.31	78.00
10 5V 1180 S	11.80	11.70	J-2	S1	4.25	1.94	1.06	0.38	1.94	4.38	3.31	93.00
10 5V 1250 U	12.50	12.40	J-2	U1	5.50	0.78	1.50	0.47	0.78	7.13	5.63	132.00
10 5V 1320 U	13.20	13.10	J-2	U1	5.50	0.78	1.50	0.47	0.78	7.13	5.63	151.00
10 5V 1400 U	14.00	13.90	J-2	U1	5.50	0.78	1.50	0.47	0.78	7.13	5.63	177.00
10 5V 1500 U	15.00	14.90	J-2	U1	5.50	0.78	1.50	0.47	0.78	7.13	5.63	164.00
10 5V 1600 U	16.00	15.90	J-3	U1	5.50	0.78	1.50	0.47	0.78	7.13	5.63	138.00
10 5V 2120 U	21.20	21.10	J-3	U1	5.50	0.78	1.50	0.47	0.78	7.13	5.63	188.00
10 5V 2500 U	25.00	24.90	J-3	U1	5.50	0.78	1.50	0.47	0.78	7.13	5.63	213.00
10 5V 2800 U	28.00	27.90	J-3	U1	5.50	0.78	1.50	0.47	0.78	7.13	5.63	238.00
10 5V 3750 U	37.50	37.40	J-3	U1	5.50	0.78	1.50	0.47	0.78	7.13	5.63	293.00
10 5V 5000 U	50.00	49.90	J-3	U1	5.50	0.78	1.50	0.47	0.78	7.13	5.63	428.00

NOTE: Dimensions in inches, weight in pounds. Weights do not include bushings 1 = Solid 2 = Web 3 = Spoked

PLEASE NOTE: Dashes are REQUIRED in place of spaces when ordering or searching on PTplace.com.

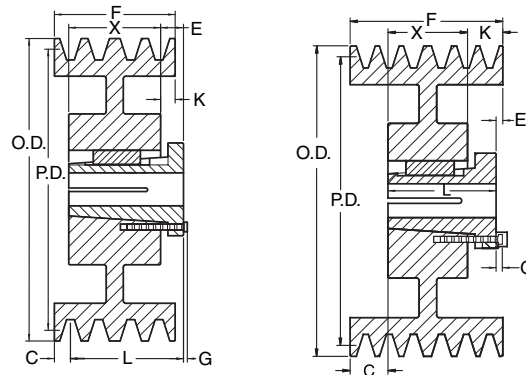

TYPE J

TYPE K

8V MST Sheaves

Nomenclature Example: 4-8V-1250-S

4 Groove F = 4-7/8												
Part Number	OD	PD	Type	Bush	Bush Max. Bore	C	E	G	K	Length Thru Bore	X	Wt. Less Bushing
		8V Belt										
4 8V 1250 S	12.50	12.30	K-2	S1	4.25	-	1.06	0.38	1.56	4.38	3.31	94.00
4 8V 1320 S	13.20	13.00	K-2	S1	4.25	-	1.06	0.38	1.56	4.38	3.31	99.00
4 8V 1400 S	14.00	13.80	K-2	S1	4.25	-	1.06	0.38	1.56	4.38	3.31	114.00
4 8V 1500 S	15.00	14.80	K-2	S1	4.25	-	1.06	0.38	1.56	4.38	3.31	107.00
4 8V 1600 S	16.00	15.80	K-2	S1	4.25	-	1.06	0.38	1.56	4.38	3.31	113.00
4 8V 1700 S	17.00	16.80	K-2	S1	4.25	-	1.06	0.38	1.56	4.38	3.31	115.00
4 8V 1800 S	18.00	17.80	K-2	S1	4.25	-	1.06	0.38	1.56	4.38	3.31	123.00
4 8V 1900 S	19.00	18.80	K-2	S1	4.25	-	1.06	0.38	1.56	4.38	3.31	132.00
4 8V 2000 S	20.00	19.80	K-2	S1	4.25	-	1.06	0.38	1.56	4.38	3.31	147.00
4 8V 2120 S	21.20	21.00	K-2	S1	4.25	-	1.06	0.38	1.56	4.38	3.31	159.00
4 8V 2240 U	22.40	22.20	J-3	U0	5.50	0.56	1.19	0.47	0.56	4.94	3.75	159.00
4 8V 3000 U	30.00	29.80	J-3	U0	5.50	0.56	1.19	0.47	0.56	4.94	3.75	218.00
4 8V 4000 U	40.00	39.80	J-3	U0	5.50	0.56	1.19	0.47	0.56	4.94	3.75	296.00
4 8V 4800 U	48.00	47.80	J-3	U0	5.50	0.56	1.19	0.47	0.56	4.94	3.75	405.00
4 8V 5300 U	53.00	52.80	J-3	U0	5.50	0.56	1.19	0.47	0.56	4.94	3.75	450.00
4 8V 5800 U	58.00	57.80	J-3	U0	5.50	0.56	1.19	0.47	0.56	4.94	3.75	495.00
4 8V 6400 U	64.00	63.80	J-3	U0	5.50	0.56	1.19	0.47	0.56	4.94	3.75	520.00

5 Groove F = 6												
Part Number	OD	PD	Type	Bush	Bush Max. Bore	C	E	G	K	Length Thru Bore	X	Wt. Less Bushing
		8V Belt										
5 8V 1250 S	12.50	12.30	K-2	S1	4.25	0.75	1.06	0.38	1.94	4.38	3.31	100.00
5 8V 1320 S	13.20	13.00	K-2	S1	4.25	0.75	1.06	0.38	1.94	4.38	3.31	109.00
5 8V 1400 S	14.00	13.80	K-2	S1	4.25	0.75	1.06	0.38	1.94	4.38	3.31	127.00
5 8V 1500 S	15.00	14.80	K-2	S1	4.25	0.75	1.06	0.38	1.94	4.38	3.31	120.00
5 8V 1600 S	16.00	15.80	K-2	S1	4.25	0.75	1.06	0.38	1.94	4.38	3.31	121.00
5 8V 1700 S	17.00	16.80	K-2	S1	4.25	0.75	1.06	0.38	1.94	4.38	3.31	133.00
5 8V 1800 S	18.00	17.80	K-2	S1	4.25	0.75	1.06	0.38	1.94	4.38	3.31	140.00
5 8V 1900 S	19.00	18.80	K-2	S1	4.25	0.75	1.06	0.38	1.94	4.38	3.31	158.00
5 8V 2000 S	20.00	19.80	K-2	S1	4.25	0.75	1.06	0.38	1.94	4.38	3.31	166.00
5 8V 2120 S	21.20	21.00	K-2	S1	4.25	0.75	1.06	0.38	1.94	4.38	3.31	174.00
5 8V 2240 U	22.40	22.20	J-3	U0	5.50	1.13	1.19	0.47	1.13	4.94	3.75	157.00
5 8V 3000 U	30.00	29.80	J-3	U0	5.50	1.13	1.19	0.47	1.13	4.94	3.75	243.00
5 8V 4000 U	40.00	39.80	J-3	U0	5.50	1.13	1.19	0.47	1.13	4.94	3.75	325.00
5 8V 4800 U	48.00	47.80	J-3	U0	5.50	1.13	1.19	0.47	1.13	4.94	3.75	440.00
5 8V 5300 U	53.00	52.80	J-3	U0	5.50	1.13	1.19	0.47	1.13	4.94	3.75	480.00
5 8V 5800 U	58.00	57.80	J-3	U0	5.50	1.13	1.19	0.47	1.13	4.94	3.75	525.00
5 8V 6400 U	64.00	63.80	J-3	U0	5.50	1.13	1.19	0.47	1.13	4.94	3.75	555.00

NOTE: Dimensions in inches, weight in pounds. Weights do not include bushings 1 = Solid 2 = Web 3 = Spoked

PLEASE NOTE: Dashes are REQUIRED in place of spaces when ordering or searching on PTplace.com.

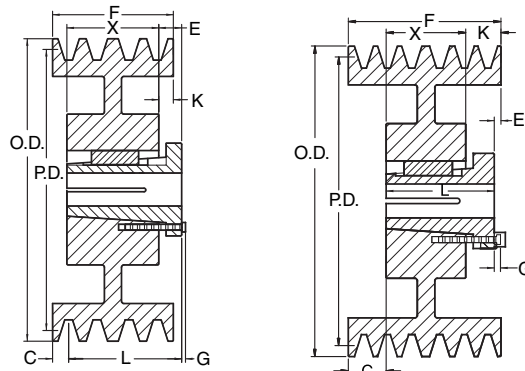

TYPE J

TYPE K

8V MST Sheaves

Nomenclature Example: **6-8V-1250-S**

6 Groove F = 7-1/8												
Part Number	OD	PD	Type	Bush	Bush Max. Bore	C	E	G	K	Length Thru Bore	X	Wt. Less Bushing
		8V Belt										
6 8V 1250 S	12.50	12.30	K-2	S1	4.25	0.75	1.06	0.38	3.06	4.38	3.31	109.00
6 8V 1320 S	13.20	13.00	K-2	S1	4.25	0.75	1.06	0.38	3.06	4.38	3.31	119.00
6 8V 1400 S	14.00	13.80	K-2	S1	4.25	0.75	1.06	0.38	3.06	4.38	3.31	135.00
6 8V 1500 S	15.00	14.80	K-2	S1	4.25	0.75	1.06	0.38	3.06	4.38	3.31	129.00
6 8V 1600 S	16.00	15.80	K-2	S1	4.25	0.75	1.06	0.38	3.06	4.38	3.31	133.00
6 8V 1700 S	17.00	16.80	K-2	S1	4.25	0.75	1.06	0.38	3.06	4.38	3.31	147.00
6 8V 1800 S	18.00	17.80	K-2	S1	4.25	0.75	1.06	0.38	3.06	4.38	3.31	154.00
6 8V 1900 S	19.00	18.80	K-2	S1	4.25	0.75	1.06	0.38	3.06	4.38	3.31	167.00
6 8V 2000 S	20.00	19.80	K-2	S1	4.25	0.75	1.06	0.38	3.06	4.38	3.31	178.00
6 8V 2120 S	21.20	21.00	K-2	S1	4.25	0.75	1.06	0.38	3.06	4.38	3.31	186.00
6 8V 2240 U	22.40	22.20	K-3	U0	5.50	1.69	1.19	0.47	1.69	4.94	3.75	195.00
6 8V 3000 U	30.00	29.80	K-3	U0	5.50	1.69	1.19	0.47	1.69	4.94	3.75	263.00
6 8V 4000 U	40.00	39.80	K-3	U0	5.50	1.69	1.19	0.47	1.69	4.94	3.75	363.00
6 8V 4800 U	48.00	47.80	K-3	U0	5.50	1.69	1.19	0.47	1.69	4.94	3.75	478.00
6 8V 5300 U	53.00	52.80	K-3	U0	5.50	1.69	1.19	0.47	1.69	4.94	3.75	510.00
6 8V 5800 U	58.00	57.80	K-3	U0	5.50	1.69	1.19	0.47	1.69	4.94	3.75	555.00
6 8V 6400 U	64.00	63.80	K-3	U0	5.50	1.69	1.19	0.47	1.69	4.94	3.75	585.00

8 Groove F = 9-3/8												
Part Number	OD	PD	Type	Bush	Bush Max. Bore	C	E	G	K	Length Thru Bore	X	Wt. Less Bushing
		8V Belt										
8 8V 1250 S	12.50	12.30	K-3	S2	4.19	0.75	1.06	0.38	2.94	6.75	5.69	140.00
8 8V 1320 S	13.20	13.00	K-2	S2	4.19	0.75	1.06	0.38	2.94	6.75	5.69	176.00
8 8V 1400 S	14.00	13.80	K-2	S2	4.19	0.75	1.06	0.38	2.94	6.75	5.69	205.00
8 8V 1500 S	15.00	14.80	K-2	S2	4.19	0.75	1.06	0.38	2.94	6.75	5.69	186.00
8 8V 1600 S	16.00	15.80	K-2	S2	4.19	0.75	1.06	0.38	2.94	6.75	5.69	210.00
8 8V 1700 U	17.00	16.80	K-3	U1	5.50	1.00	1.50	0.47	2.75	7.13	5.63	248.00
8 8V 1800 U	18.00	17.80	K-2	U1	5.50	1.00	1.50	0.47	2.75	7.13	5.63	249.00
8 8V 1900 U	19.00	18.80	K-2	U1	5.50	1.00	1.50	0.47	2.75	7.13	5.63	235.00
8 8V 2000 U	20.00	19.80	K-2	U1	5.50	1.00	1.50	0.47	2.75	7.13	5.63	251.00
8 8V 2120 U	21.20	21.00	K-2	U1	5.50	1.00	1.50	0.47	2.75	7.13	5.63	268.00
8 8V 2240 U	22.40	22.20	K-2	U1	5.50	1.88	1.50	0.47	1.88	7.13	5.63	253.00
8 8V 3000 U	30.00	29.80	K-3	U1	5.50	1.88	1.50	0.47	1.88	7.13	5.63	358.00
8 8V 4000 W	40.00	39.80	K-3	W1	7.44	1.50	1.88	0.56	1.50	1.44	6.38	567.00
8 8V 4800 W	48.00	47.80	J-3	W1	7.44	1.50	1.88	0.56	1.50	1.44	6.38	715.00
8 8V 5300 W	53.00	52.80	J-3	W1	7.44	1.50	1.88	0.56	1.50	1.44	6.38	762.00
8 8V 5800 W	58.00	57.80	J-3	W1	7.44	1.50	1.88	0.56	1.50	1.44	6.38	914.00
8 8V 6400 W	64.00	63.80	J-3	W1	7.44	1.50	1.88	0.56	1.50	1.44	6.38	970.00

NOTE: Dimensions in inches, weight in pounds. Weights do not include bushings

1 = Solid

2 = Web

3 = Spoked

PLEASE NOTE: Dashes are REQUIRED in place of spaces when ordering or searching on PTplace.com.

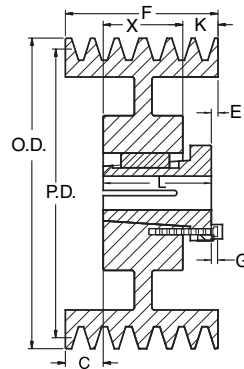

TYPE K

8V MST Sheaves

Nomenclature Example: 10-8V-1250-U

10 Groove												
F = 11-5/8												
Part Number	OD	PD	Type	Bush	Bush Max. Bore	C	E	G	K	Length Thru Bore	X	Wt. Less Bushing
		8V Belt										
10 8V 1250 U	12.50	12.30	K-2	U1	5.50	1.00	1.50	0.47	5.00	7.13	5.63	156.00
10 8V 1320 U	13.20	13.00	K-2	U1	5.50	1.00	1.50	0.47	5.00	7.13	5.63	182.00
10 8V 1400 U	14.00	13.80	K-2	U1	5.50	1.00	1.50	0.47	5.00	7.13	5.63	207.00
10 8V 1500 U	15.00	14.80	K-2	U1	5.50	1.00	1.50	0.47	5.00	7.13	5.63	240.00
10 8V 1600 U	16.00	15.80	K-2	U1	5.50	1.00	1.50	0.47	5.00	7.13	5.63	283.00
10 8V 1700 U	17.00	16.80	K-2	U1	5.50	1.00	1.50	0.47	5.00	7.13	5.63	274.00
10 8V 1800 U	18.00	17.80	K-2	U1	5.50	1.00	1.50	0.47	5.00	7.13	5.63	282.00
10 8V 1900 U	19.00	18.80	K-2	U1	5.50	1.00	1.50	0.47	5.00	7.13	5.63	264.00
10 8V 2000 U	20.00	19.80	K-2	U1	5.50	1.00	1.50	0.47	5.00	7.13	5.63	279.00
10 8V 2120 U	21.20	21.00	K-2	U1	5.50	1.00	1.50	0.47	5.00	7.13	5.63	296.00
10 8V 2240 U	22.40	22.20	K-3	U1	5.50	3.00	1.50	0.47	3.00	7.13	5.63	309.00
10 8V 3000 U	30.00	29.80	K-3	U1	5.50	3.00	1.50	0.47	3.00	7.13	5.63	410.00
10 8V 4000 W	40.00	39.80	K-3	W1	7.44	2.63	1.88	0.56	2.63	1.44	6.38	625.00
10 8V 4800 W	48.00	47.80	K-3	W1	7.44	2.63	1.88	0.56	2.63	1.44	6.38	811.00
10 8V 5300 W	53.00	52.80	K-3	W1	7.44	2.63	1.88	0.56	2.63	1.44	6.38	955.00
10 8V 5800 W	58.00	57.80	K-3	W1	7.44	2.63	1.88	0.56	2.63	1.44	6.38	1060.00
10 8V 6400 W	64.00	63.80	K-3	W1	7.44	2.63	1.88	0.56	2.63	1.44	6.38	1170.00

12 Groove												
F = 13-7/8												
Part Number	OD	PD	Type	Bush	Bush Max. Bore	C	E	G	K	Length Thru Bore	X	Wt. Less Bushing
		8V Belt										
12 8V 1250 U	12.50	12.30	K-2	U2	5.00	1.00	1.50	0.47	4.25	1.06	8.63	200.00
12 8V 1320 U	13.20	13.00	K-2	U2	5.00	1.00	1.50	0.47	4.25	1.06	8.63	243.00
12 8V 1400 U	14.00	13.80	K-2	U2	5.00	1.00	1.50	0.47	4.25	1.06	8.63	282.00
12 8V 1500 U	15.00	14.80	K-2	U2	5.00	1.00	1.50	0.47	4.25	1.06	8.63	331.00
12 8V 1600 U	16.00	15.80	K-2	U2	5.00	1.00	1.50	0.47	4.25	1.06	8.63	387.00
12 8V 1700 U	17.00	16.80	K-2	U2	5.00	1.00	1.50	0.47	4.25	1.06	8.63	395.00
12 8V 1800 U	18.00	17.80	K-2	U2	5.00	1.00	1.50	0.47	4.25	1.06	8.63	408.00
12 8V 1900 U	19.00	18.80	K-2	U2	5.00	1.00	1.50	0.47	4.25	1.06	8.63	435.00
12 8V 2000 U	20.00	19.80	K-2	U2	5.00	1.00	1.50	0.47	4.25	1.06	8.63	428.00
12 8V 2120 U	21.20	21.00	K-2	U2	5.00	1.00	1.50	0.47	4.25	1.06	8.63	450.00
12 8V 2240 U	22.40	22.20	K-3	U2	5.00	2.63	1.50	0.47	2.63	1.06	8.63	421.00
12 8V 3000 U	30.00	29.80	K-3	U2	5.00	2.63	1.50	0.47	2.63	1.06	8.63	509.00
12 8V 4000 W	40.00	39.80	K-3	W2	7.44	2.25	1.88	0.56	11.63	11.25	0.00	764.00
12 8V 4800 W	48.00	47.80	K-3	W2	7.44	2.25	1.88	0.56	11.63	11.25	0.00	1000.00
12 8V 5300 W	53.00	52.80	K-3	W2	7.44	2.25	1.88	0.56	11.63	11.25	0.00	1160.00
12 8V 5800 W	58.00	57.80	K-3	W2	7.44	2.25	1.88	0.56	11.63	11.25	0.00	1330.00
12 8V 6400 W	64.00	63.80	K-3	W2	7.44	2.25	1.88	0.56	11.63	11.25	0.00	1460.00

NOTE: Dimensions in inches, weight in pounds. Weights do not include bushings 1 = Solid 2 = Web 3 = Spoked

PLEASE NOTE: Dashes are REQUIRED in place of spaces when ordering or searching on PTplace.com.

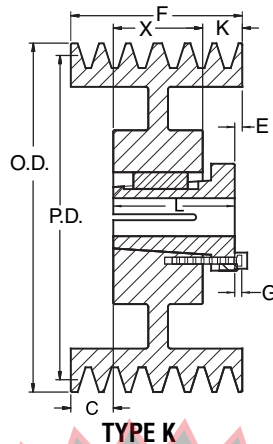

8V MST Sheaves

Nomenclature Example: **14-8V-1250-U**

14 Groove F = 16-1/8													
Part Number	OD	PD		Type	Bush	Bush Max. Bore	C	E	G	K	Length Thru Bore	X	Wt. Less Bushing
		8V Belt											
14 8V 1250 U	12.50	12.30		K-2	U2	5.00	1.00	1.50	0.47	6.50	1.06	8.63	220.00
14 8V 1320 U	13.20	13.00		K-2	U2	5.00	1.00	1.50	0.47	6.50	1.06	8.63	261.00
14 8V 1400 U	14.00	13.80		K-2	U2	5.00	1.00	1.50	0.47	6.50	1.06	8.63	300.00
14 8V 1500 U	15.00	14.80		K-2	U2	5.00	1.00	1.50	0.47	6.50	1.06	8.63	370.00
14 8V 1600 U	16.00	15.80		K-2	U2	5.00	1.00	1.50	0.47	6.50	1.06	8.63	415.00
14 8V 1700 U	17.00	16.80		K-2	U2	5.00	1.00	1.50	0.47	6.50	1.06	8.63	440.00
14 8V 1800 U	18.00	17.80		K-2	U2	5.00	1.00	1.50	0.47	6.50	1.06	8.63	450.00
14 8V 1900 U	19.00	18.80		K-2	U2	5.00	1.00	1.50	0.47	6.50	1.06	8.63	470.00
14 8V 2000 U	20.00	19.80		K-2	U2	5.00	1.00	1.50	0.47	6.50	1.06	8.63	490.00
14 8V 2120 U	21.20	21.00		K-2	U2	5.00	1.00	1.50	0.47	6.50	1.06	8.63	510.00
14 8V 2240 U	22.40	22.20		K-3	U2	5.00	3.75	1.50	0.47	3.75	1.06	8.63	459.00
14 8V 3000 U	30.00	29.80		K-3	U2	5.00	3.75	1.50	0.47	3.75	1.06	8.63	710.00
14 8V 4000 W	40.00	39.80		K-3	W2	7.44	3.38	1.88	0.56	12.75	11.25	0.00	840.00
14 8V 4800 W	48.00	47.80		K-3	W2	7.44	3.38	1.88	0.56	12.75	11.25	0.00	1140.00
14 8V 5300 W	53.00	52.80		K-3	W2	7.44	3.38	1.88	0.56	12.75	11.25	0.00	1234.00
14 8V 5800 W	58.00	57.80		K-3	W2	7.44	3.38	1.88	0.56	12.75	11.25	0.00	1450.00
14 8V 6400 W	64.00	63.80		K-3	W2	7.44	3.38	1.88	0.56	12.75	11.25	0.00	1550.00

16 Groove F = 18-3/8													
Part Number	OD	PD		Type	Bush	Bush Max. Bore	C	E	G	K	Length Thru Bore	X	Wt. Less Bushing
		8V Belt											
16 8V 1250 U	12.50	12.30		K-2	U2	5.00	1.00	1.50	0.47	8.75	1.06	8.63	270.00
16 8V 1320 U	13.20	13.00		K-2	U2	5.00	1.00	1.50	0.47	8.75	1.06	8.63	280.00
16 8V 1400 U	14.00	13.80		K-2	U2	5.00	1.00	1.50	0.47	8.75	1.06	8.63	323.00
16 8V 1500 U	15.00	14.80		K-2	U2	5.00	1.00	1.50	0.47	8.75	1.06	8.63	430.00
16 8V 1600 U	16.00	15.80		K-2	U2	5.00	1.00	1.50	0.47	8.75	1.06	8.63	445.00
16 8V 1700 U	17.00	16.80		K-2	U2	5.00	1.00	1.50	0.47	8.75	1.06	8.63	447.00
16 8V 1800 U	18.00	17.80		K-2	U2	5.00	1.00	1.50	0.47	8.75	1.06	8.63	480.00
16 8V 1900 U	19.00	18.80		K-2	U2	5.00	1.00	1.50	0.47	8.75	1.06	8.63	494.00
16 8V 2000 U	20.00	19.80		K-2	U2	5.00	1.00	1.50	0.47	8.75	1.06	8.63	520.00
16 8V 2120 U	21.20	21.00		K-2	U2	5.00	1.00	1.50	0.47	8.75	1.06	8.63	538.00
16 8V 2240 U	22.40	22.20		K-3	U2	5.00	4.88	1.50	0.47	4.88	1.06	8.63	522.00
16 8V 3000 W	30.00	29.80		K-3	W2	7.44	4.50	1.88	0.56	13.88	11.25	0.00	990.00
16 8V 4000 W	40.00	39.80		K-3	W2	7.44	4.50	1.88	0.56	13.88	11.25	0.00	871.00
16 8V 4800 W	48.00	47.80		K-3	W2	7.44	4.50	1.88	0.56	13.88	11.25	0.00	1360.00
16 8V 5300 W	53.00	52.80		K-3	W2	7.44	4.50	1.88	0.56	13.88	11.25	0.00	1490.00
16 8V 5800 W	58.00	57.80		K-3	W2	7.44	4.50	1.88	0.56	13.88	11.25	0.00	1620.00
16 8V 6400 W	64.00	63.80		K-3	W2	7.44	4.50	1.88	0.56	13.88	11.25	0.00	1790.00

NOTE: Dimensions in inches, weight in pounds. Weights do not include bushings 1 = Solid 2 = Web 3 = Spoked

PLEASE NOTE: Dashes are REQUIRED in place of spaces when ordering or searching on PTplace.com.

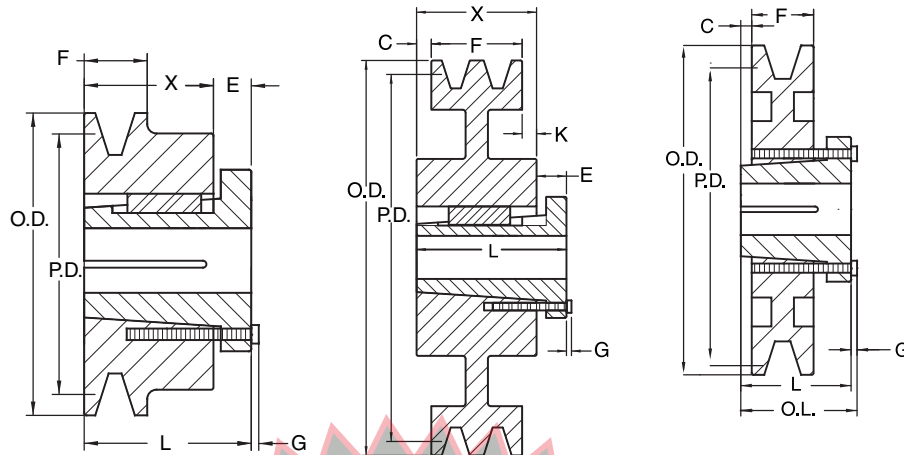

TYPE G

TYPE L

TYPE M

A-B MST Sheaves

Nomenclature Example: 1-B-34-P

1 Groove													
F = 1													
Part Number	OD	PD		Type	Bush	Bush Max. Bore	C	E	G	K	Length Thru Bore	X	Wt. Less Bushing
		A	B										
1 B 34 P	3.75	3.00	3.40	G-1	P1	1.75	0.13	0.63	0.25	0.44	1.94	1.31	2.00
1 B 36 P	3.95	3.20	3.60	G-1	P1	1.75	0.13	0.63	0.25	0.44	1.94	1.31	2.30
1 B 38 P	4.15	3.40	3.80	G-1	P1	1.75	0.13	0.63	0.25	0.44	1.94	1.31	2.60
1 B 40 P	4.35	3.60	4.00	M-1	P1	1.75	0.31	-	0.25	0.63	1.94	1.31	2.10
1 B 42 P	4.55	3.80	4.20	M-1	P1	1.75	0.31	-	0.25	0.63	1.94	1.31	2.40
1 B 44 P	4.75	4.00	4.40	M-1	P1	1.75	0.31	-	0.25	0.63	1.94	1.31	2.80
1 B 46 P	4.95	4.20	4.60	M-1	P1	1.75	0.31	-	0.25	0.63	1.94	1.31	3.10
1 B 48 P	5.15	4.40	4.80	M-1	P1	1.75	0.31	-	0.25	0.66	1.94	1.31	3.50
1 B 50 P	5.35	4.60	5.00	M-1	P1	1.75	0.31	-	0.25	0.63	1.94	1.31	3.90
1 B 52 P	5.55	4.80	5.20	M-1	P1	1.75	0.31	-	0.25	0.63	1.94	1.31	4.10
1 B 54 P	5.75	5.00	5.40	M-1	P1	1.75	0.31	-	0.25	0.63	1.94	1.31	4.60
1 B 56 P	5.95	5.20	5.60	M-1	P1	1.75	0.31	-	0.25	0.63	1.94	1.31	5.10
1 B 58 P	6.15	5.40	5.80	M-1	P1	1.75	0.31	-	0.25	0.65	1.94	1.31	5.60
1 B 60 P	6.35	5.60	6.00	M-1	P1	1.75	0.31	-	0.25	0.63	1.94	1.31	6.00
1 B 62 P	6.55	5.80	6.20	M-2	P1	1.75	0.31	-	0.25	0.63	1.94	1.31	5.50
1 B 64 P	6.75	6.00	6.40	M-1	P1	1.75	0.31	-	0.25	0.63	1.94	1.31	5.80
1 B 66 P	6.95	6.20	6.60	M-1	P1	1.75	0.31	-	0.25	0.63	1.94	1.31	5.90
1 B 68 P	7.15	6.40	6.80	M-1	P1	1.75	0.31	-	0.25	0.63	1.94	1.31	6.10
1 B 70 P	7.35	6.60	7.00	L-1	P1	1.75	0.16	0.63	0.25	0.47	1.94	1.31	6.40
1 B 74 P	7.75	7.00	7.40	L-2	P1	1.75	0.16	0.63	0.25	0.47	1.94	1.31	7.30
1 B 80 P	8.35	7.60	8.00	L-2	P1	1.75	0.16	0.63	0.25	0.47	1.94	1.31	7.80
1 B 86 P	8.95	8.20	8.60	L-2	P1	1.75	0.16	0.63	0.25	0.47	1.94	1.31	8.60
1 B 90 P	9.35	8.60	9.00	L-2	P1	1.75	0.16	0.63	0.25	0.47	1.94	1.31	8.90
1 B 94 P	9.75	9.00	9.40	L-3	P1	1.75	0.16	0.63	0.25	0.47	1.94	1.31	9.10
1 B 110 P	11.35	10.60	11.00	L-2	P1	1.75	0.16	0.63	0.25	0.47	1.94	1.31	11.10
1 B 124 Q	12.75	12.00	12.40	L-3	Q1	2.69	0.38	0.75	0.28	1.13	2.50	1.75	17.80
1 B 136 Q	13.95	13.20	13.60	L-3	Q1	2.69	0.38	0.75	0.28	1.13	2.50	1.75	18.20
1 B 154 Q	15.75	15.00	15.40	L-3	Q1	2.69	0.38	0.75	0.28	1.13	2.50	1.75	20.30
1 B 160 Q	16.35	15.60	16.00	L-3	Q1	2.69	0.38	0.75	0.28	1.13	2.50	1.75	22.00
1 B 184 Q	18.75	18.00	18.40	L-3	Q1	2.69	0.38	0.75	0.28	1.13	2.50	1.75	27.50
1 B 200 Q	20.35	19.50	20.00	L-3	Q1	2.69	0.38	0.75	0.28	1.13	2.50	1.75	27.20
1 B 250 Q	25.35	24.50	25.00	L-3	Q1	2.69	0.38	0.75	0.28	1.13	2.50	1.75	42.40
1 B 300 Q	30.35	29.50	30.00	L-3	Q1	2.69	0.38	0.75	0.28	1.13	2.50	1.75	56.00
1 B 380 Q	38.35	37.50	38.00	L-3	Q1	2.69	0.38	0.75	0.28	1.13	2.50	1.75	78.00

NOTE: Dimensions in inches, weight in pounds. Weights do not include bushings 1 = Solid 2 = Web 3 = Spoked

PLEASE NOTE: Dashes are REQUIRED in place of spaces when ordering or searching on PTplace.com.

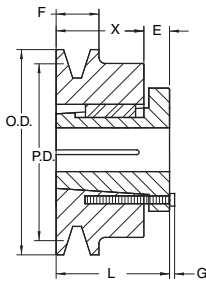

TYPE G

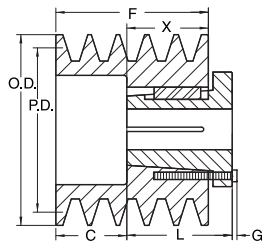

TYPE S

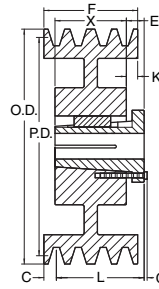

TYPE J

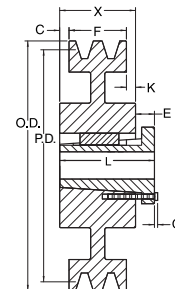

TYPE L

A-B MST Sheaves

Nomenclature Example: **2-B-34-P**

2 Groove													
F = 1-3/4													
Part Number	OD	PD		Type	Bush	Bush Max. Bore	C	E	G	K	Length Thru Bore	X	Wt. Less Bushing
		A	B										
2 B 34 P	3.75	3.00	3.40	G-1	P1	1.75	0.88	0.63	0.25	1.31	1.31	2.19	2.90
2 B 36 P	3.95	3.20	3.60	G-1	P1	1.75	0.88	0.63	0.25	1.31	1.94	2.19	3.80
2 B 38 P	4.15	3.40	3.80	S-1	P1	1.75	0.44	—	0.25	—	1.31	1.31	3.00
2 B 40 P	4.35	3.60	4.00	S-1	P1	1.75	0.44	—	0.25	—	1.31	1.31	3.80
2 B 42 P	4.55	3.80	4.20	S-1	P1	1.75	0.44	—	0.25	—	1.94	1.31	3.90
2 B 44 P	4.75	4.00	4.40	J-1	P1	1.75	—	0.63	0.25	0.44	1.31	1.31	3.90
2 B 46 P	4.95	4.20	4.60	J-1	P1	1.75	—	0.63	0.25	0.44	1.31	1.31	4.50
2 B 48 P	5.15	4.40	4.80	J-1	P1	1.75	—	0.63	0.25	0.44	1.94	1.31	5.30
2 B 50 P	5.35	4.60	5.00	J-1	P1	1.75	—	0.63	0.25	0.44	1.31	1.31	5.60
2 B 52 P	5.55	4.80	5.20	J-1	P1	1.75	—	0.63	0.25	0.44	1.94	1.31	6.10
2 B 54 P	5.75	5.00	5.40	J-1	P1	1.75	—	0.63	0.25	0.44	1.31	1.31	6.50
2 B 54 Q	5.75	5.00	5.40	S-1	Q1	2.69	—	0.63	0.28	—	2.50	1.75	6.00
2 B 56 P	5.95	5.20	5.60	J-1	P1	1.75	—	0.63	0.25	0.44	1.31	1.31	7.40
2 B 56 Q	5.95	5.20	5.60	S-1	Q1	2.69	—	0.63	0.28	—	2.50	1.75	7.30
2 B 58 P	6.15	5.40	5.80	J-1	P1	1.75	—	0.63	0.25	0.44	1.31	1.31	8.00
2 B 58 Q	6.15	5.40	5.80	S-1	Q1	2.69	—	0.63	0.28	—	2.50	1.75	7.90
2 B 60 P	6.35	5.60	6.00	J-1	P1	1.75	—	0.63	0.25	0.44	1.31	1.31	8.90
2 B 60 Q	6.35	5.60	6.00	S-1	Q1	2.69	—	0.63	0.28	—	2.50	1.75	8.90
2 B 62 P	6.55	5.80	6.20	J-2	P1	1.75	—	0.63	0.25	0.44	1.31	1.31	7.60
2 B 62 Q	6.55	5.80	6.20	S-1	Q1	2.69	—	0.63	0.28	—	2.50	1.75	9.40
2 B 64 P	6.75	6.00	6.40	J-2	P1	1.75	—	0.63	0.25	0.44	1.31	1.31	7.80
2 B 64 Q	6.75	6.00	6.40	S-1	Q1	2.69	—	0.63	0.28	—	2.50	1.75	10.10
2 B 66 P	6.95	6.20	6.60	J-2	P1	1.75	—	0.63	0.25	0.44	1.31	1.31	8.30
2 B 66 Q	6.95	6.20	6.60	S-1	Q1	2.69	—	0.63	0.28	—	2.50	1.75	11.10
2 B 68 P	7.15	6.40	6.80	J-2	P1	1.75	—	0.63	0.25	0.44	1.31	1.31	8.80
2 B 68 Q	7.15	6.40	6.80	S-1	Q1	2.69	—	0.63	0.28	—	2.50	1.75	12.30
2 B 70 Q	7.35	6.60	7.00	J-2	Q1	2.69	—	0.75	0.28	—	1.75	1.75	11.10
2 B 74 Q	7.75	7.00	7.40	J-2	Q1	2.69	—	0.75	0.28	—	2.50	1.75	11.50
2 B 80 Q	8.35	7.60	8.00	J-2	Q1	2.69	—	0.75	0.28	—	1.75	1.75	12.80
2 B 86 Q	8.95	8.20	8.60	J-2	Q1	2.69	—	0.75	0.28	—	2.50	1.75	16.00
2 B 90 Q	9.35	8.60	9.00	J-3	Q1	2.69	—	0.75	0.28	—	1.75	1.75	15.10
2 B 94 Q	9.75	9.00	9.40	J-3	Q1	2.69	—	0.75	0.28	—	2.50	1.75	15.50
2 B 110 Q	11.35	10.60	11.00	J-3	Q1	2.69	—	0.75	0.28	—	1.75	1.75	18.90
2 B 124 Q	12.75	12.00	12.40	J-3	Q1	2.69	—	0.75	0.28	—	1.75	1.75	21.10
2 B 136 Q	13.95	13.20	13.60	J-3	Q1	2.69	—	0.75	0.28	—	2.50	1.75	23.00
2 B 154 Q	15.75	15.00	15.40	J-3	Q1	2.69	—	0.75	0.28	—	1.75	1.75	24.80
2 B 154 R	15.75	15.00	15.40	L-3	R1	3.75	0.13	0.75	0.28	0.25	2.88	2.00	30.60
2 B 160 Q	16.35	15.60	16.00	J-3	Q1	2.69	—	0.75	0.28	—	1.75	1.75	27.00
2 B 160 R	16.35	15.60	16.00	L-3	R1	3.75	0.13	0.75	0.28	0.25	2.88	2.00	32.00
2 B 184 Q	18.75	18.00	18.40	J-3	Q1	2.69	—	0.75	0.28	—	1.75	1.75	32.30
2 B 184 R	18.75	18.00	18.40	L-3	R1	3.75	0.13	0.75	0.28	0.38	2.88	2.00	39.10
2 B 200 Q	20.35	19.50	20.00	J-3	Q1	2.69	—	0.75	0.28	—	1.75	1.75	42.30
2 B 200 R	20.35	19.50	20.00	L-3	R1	3.75	0.13	0.75	0.28	0.25	2.88	2.00	43.50
2 B 250 Q	25.35	24.50	25.00	J-3	Q1	2.69	—	0.75	0.28	—	1.75	1.75	50.30
2 B 250 R	25.35	24.50	25.00	L-3	R1	3.75	0.13	0.75	0.28	0.25	2.88	2.00	58.00
2 B 300 Q	30.35	29.50	30.00	J-3	Q1	2.69	—	0.75	0.28	—	1.75	1.75	68.80
2 B 300 R	30.35	29.50	30.00	L-3	R1	3.75	0.13	0.75	0.28	0.25	2.88	2.00	81.00
2 B 380 Q	38.35	37.50	38.00	J-3	Q1	2.69	—	0.75	0.28	—	1.75	1.75	95.50
2 B 380 R	38.35	37.50	38.00	L-3	R1	3.75	0.13	0.75	0.28	0.25	2.88	2.00	92.00

NOTE: Dimensions in inches, weight in pounds. Weights do not include bushings

1 = Solid

2 = Web

3 = Spoked

PLEASE NOTE: Dashes are REQUIRED in place of spaces when ordering or searching on PTplace.com.

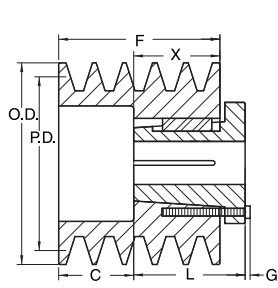

TYPE S

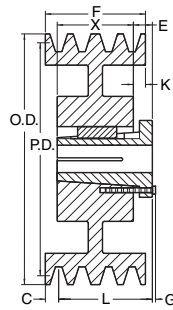

TYPE J

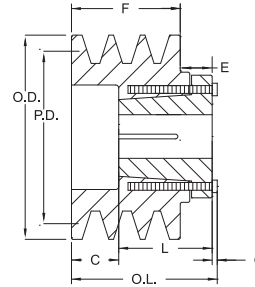

TYPE N

A-B MST Sheaves

Nomenclature Example: **3-B-34-P**

3 Groove													
F = 2-1/2													
Part Number	OD	PD		Type	Bush	Bush Max. Bore	C	E	G	K	Length Thru Bore	X	Wt. Less Bushing
		A	B										
3 B 34 P	3.75	3.00	3.40	G-1	P2	1.75	0.63	0.63	0.25	0.44	2.94	2.31	3.80
3 B 36 P	3.95	3.20	3.60	N-1	P2	1.75	0.63	0.63	0.25	0.44	2.31	2.31	4.40
3 B 38 P	4.15	3.40	3.80	S-1	P1	1.75	1.19	—	0.25	—	1.94	1.31	3.80
3 B 40 P	4.35	3.60	4.00	S-1	P1	1.75	1.19	—	0.25	—	1.94	1.31	4.50
3 B 42 P	4.55	3.80	4.20	S-1	P1	1.75	1.19	—	0.25	—	1.31	1.31	4.90
3 B 44 P	4.75	4.00	4.40	J-1	P1	1.75	0.56	0.63	0.25	0.63	1.94	1.31	5.10
3 B 46 P	4.95	4.20	4.60	J-2	P1	1.75	0.56	0.63	0.25	0.63	1.31	1.31	6.00
3 B 48 P	5.15	4.40	4.80	J-2	P1	1.75	0.56	0.63	0.25	0.63	1.94	1.31	6.30
3 B 50 P	5.35	4.60	5.00	J-2	P1	1.75	0.56	0.63	0.25	0.63	1.31	1.31	6.90
3 B 52 P	5.55	4.80	5.20	J-2	P1	1.75	0.56	0.63	0.25	0.63	1.94	1.31	7.50
3 B 54 P	5.75	5.00	5.40	J-2	P1	1.75	0.56	0.63	0.25	0.63	1.31	1.31	8.30
3 B 54 Q	5.75	5.00	5.40	S-1	Q1	2.69	0.56	0.63	0.28	0.19	2.50	1.75	7.90
3 B 56 P	5.95	5.20	5.60	J-2	P1	1.75	0.56	0.63	0.25	0.63	1.31	1.31	9.00
3 B 56 Q	5.95	5.20	5.60	S-1	Q1	2.69	0.75	0.63	0.28	—	2.50	1.75	9.00
3 B 58 P	6.15	5.40	5.80	J-2	P1	1.75	0.56	0.63	0.25	0.63	1.31	1.31	9.60
3 B 58 Q	6.15	5.40	5.80	J-2	Q1	2.69	0.56	0.63	0.28	0.19	2.50	1.75	9.40
3 B 60 P	6.35	5.60	6.00	J-2	P1	1.75	0.56	0.63	0.25	0.63	1.31	1.31	10.50
3 B 60 Q	6.35	5.60	6.00	J-2	Q1	2.69	0.38	0.63	0.28	0.38	2.50	1.75	10.40
3 B 62 P	6.55	5.80	6.20	J-2	P1	1.75	0.56	0.63	0.25	0.63	1.31	1.31	9.40
3 B 62 Q	6.55	5.80	6.20	J-2	Q1	2.69	0.56	0.63	0.28	0.19	2.50	1.75	11.30
3 B 64 P	6.75	6.00	6.40	J-2	P1	1.75	0.56	0.63	0.25	0.63	1.31	1.31	9.50
3 B 64 Q	6.75	6.00	6.40	J-2	Q1	2.69	0.38	0.63	0.28	0.38	2.50	1.75	12.10
3 B 66 P	6.95	6.20	6.60	J-2	P1	1.75	0.56	0.63	0.25	0.63	1.31	1.31	10.00
3 B 66 Q	6.95	6.20	6.60	J-2	Q1	2.69	0.56	0.63	0.28	0.19	2.50	1.75	13.00
3 B 68 P	7.15	6.40	6.80	J-2	P1	1.75	0.56	0.63	0.25	0.63	1.31	1.31	10.40
3 B 68 Q	7.15	6.40	6.80	J-2	Q1	2.69	0.56	0.63	0.28	0.19	2.50	1.75	14.30
3 B 70 Q	7.35	6.60	7.00	J-2	Q1	2.69	0.38	0.75	0.28	0.38	1.75	1.75	13.00
3 B 74 Q	7.75	7.00	7.40	J-2	Q1	2.69	0.38	0.75	0.28	0.38	2.50	1.75	0.00
3 B 80 Q	8.35	7.60	8.00	J-2	Q1	2.69	0.38	0.75	0.28	0.38	1.75	1.75	15.30
3 B 86 Q	8.95	8.20	8.60	J-2	Q1	2.69	0.38	0.75	0.28	0.38	2.50	1.75	0.00
3 B 90 Q	9.35	8.60	9.00	J-3	Q1	2.69	0.38	0.75	0.28	0.38	1.75	1.75	18.10
3 B 94 Q	9.75	9.00	9.40	J-3	Q1	2.69	0.38	0.75	0.28	0.38	2.50	1.75	0.00
3 B 110 Q	11.35	10.60	11.00	J-3	Q1	2.69	0.38	0.75	0.28	0.38	1.75	1.75	21.30
3 B 124 Q	12.75	12.00	12.40	J-3	Q1	2.69	0.38	0.75	0.28	0.38	2.50	1.75	25.40
3 B 136 Q	13.95	13.20	13.60	J-3	Q1	2.69	0.38	0.75	0.28	0.38	1.75	1.75	27.40
3 B 154 Q	15.75	15.00	15.40	J-3	Q1	2.69	0.38	0.75	0.28	0.38	1.75	1.75	29.80
3 B 154 R	15.75	15.00	15.40	J-3	R1	3.75	0.38	0.75	0.28	0.13	2.88	2.00	35.50
3 B 160 Q	16.35	15.60	16.00	J-3	Q1	2.69	0.38	0.75	0.28	0.38	1.75	1.75	32.00
3 B 160 R	16.35	15.60	16.00	J-3	R1	3.75	0.38	0.75	0.28	0.13	2.88	2.00	38.00
3 B 184 Q	18.75	18.00	18.40	J-3	Q1	2.69	0.38	0.75	0.28	0.38	1.75	1.75	37.80
3 B 184 R	18.75	18.00	18.40	J-3	R1	3.75	0.38	0.75	0.28	0.13	2.88	2.00	44.80
3 B 200 Q	20.35	19.50	20.00	J-3	Q1	2.69	0.38	0.75	0.28	0.38	1.75	1.75	49.90
3 B 200 R	20.35	19.50	20.00	J-3	R1	3.75	0.38	0.75	0.28	0.13	2.88	2.00	50.30
3 B 250 Q	25.35	24.50	25.00	J-3	Q1	2.69	0.38	0.75	0.28	0.38	1.75	1.75	61.00
3 B 250 R	25.35	24.50	25.00	J-3	R1	3.75	0.38	0.75	0.28	0.13	2.88	2.00	65.00
3 B 300 Q	30.35	29.50	30.00	J-3	Q1	2.69	0.38	0.75	0.28	0.38	1.75	1.75	78.50
3 B 300 R	30.35	29.50	30.00	J-3	R1	3.75	0.38	0.75	0.28	0.13	2.88	2.00	89.00
3 B 380 Q	38.35	37.50	38.00	J-3	Q1	2.69	0.38	0.75	0.28	0.38	1.75	1.75	110.00
3 B 380 R	38.35	37.50	38.00	J-3	R1	3.75	0.38	0.75	0.28	0.13	2.88	2.00	106.00

NOTE: Dimensions in inches, weight in pounds. Weights do not include bushings 1 = Solid 2 = Web 3 = Spoked

PLEASE NOTE: Dashes are REQUIRED in place of spaces when ordering or searching on PTplace.com.

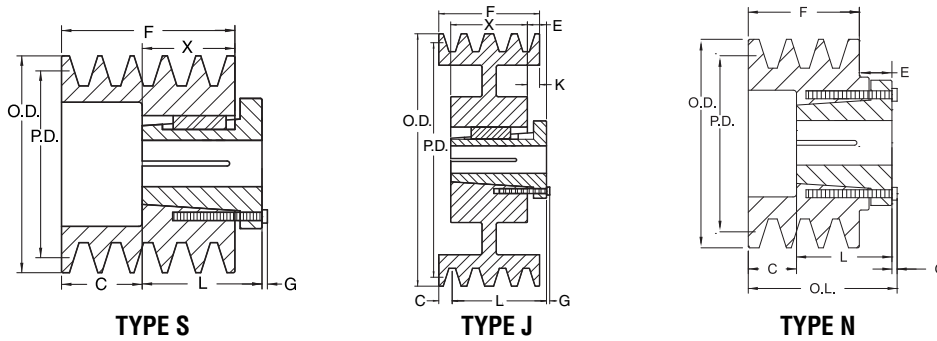

TYPE S

TYPE J

TYPE N

A-B MST Sheaves

Nomenclature Example: 4-B-34-P

4 Groove													
F = 3-1/4													
Part Number	OD	PD		Type	Bush	Bush Max. Bore	C	E	G	K	Length Thru Bore	X	Wt. Less Bushing
		A	B										
4 B 34 P	3.75	3.00	3.40	G-1	P2	1.75	1.38	0.63	0.25	0.44	2.94	2.31	4.50
4 B 36 P	3.95	3.20	3.60	N-1	P2	1.75	1.38	0.63	0.25	0.44	2.31	2.31	5.30
4 B 38 P	4.15	3.40	3.80	S-1	P1	1.75	1.94	-	0.25	-	1.94	1.31	4.80
4 B 40 P	4.35	3.60	4.00	J-2	P1	1.75	1.94	-	0.25	-	1.94	1.31	5.50
4 B 42 P	4.55	3.80	4.20	S-1	P1	1.75	1.94	-	0.25	-	1.31	1.31	5.90
4 B 44 P	4.75	4.00	4.40	J-2	P1	1.75	1.31	0.63	0.25	0.63	1.94	1.31	6.50
4 B 46 P	4.95	4.20	4.60	J-2	P1	1.75	1.31	0.63	0.25	0.63	1.31	1.31	7.10
4 B 48 P	5.15	4.40	4.80	J-2	P1	1.75	1.31	0.63	0.25	0.63	1.94	1.31	7.50
4 B 50 P	5.35	4.60	5.00	J-2	P1	1.75	1.31	0.63	0.25	0.63	1.31	1.31	8.30
4 B 52 P	5.55	4.80	5.20	J-2	P1	1.75	1.31	0.63	0.25	0.63	1.94	1.31	9.10
4 B 54 P	5.75	5.00	5.40	J-2	P1	1.75	1.31	0.63	0.25	0.63	1.31	1.31	9.60
4 B 54 Q	5.75	5.00	5.40	S-1	Q1	2.69	1.31	0.63	0.28	0.19	2.50	1.75	9.30
4 B 56 P	5.95	5.20	5.60	J-2	P1	1.75	1.31	0.63	0.25	0.63	1.31	1.31	10.60
4 B 56 Q	5.95	5.20	5.60	S-1	Q1	2.69	1.31	0.63	0.28	0.19	2.50	1.75	10.50
4 B 58 P	6.15	5.40	5.80	J-2	P1	1.75	1.31	0.63	0.25	0.63	1.31	1.31	11.60
4 B 58 Q	6.15	5.40	5.80	J-2	Q1	2.69	1.31	0.63	0.28	0.19	2.50	1.75	11.50
4 B 60 P	6.35	5.60	6.00	J-2	P1	1.75	1.31	0.63	0.25	0.63	1.31	1.31	11.90
4 B 60 Q	6.35	5.60	6.00	J-2	Q1	2.69	1.31	0.63	0.28	0.19	2.50	1.75	12.60
4 B 62 P	6.55	5.80	6.20	J-2	P1	1.75	1.31	0.63	0.25	0.63	1.31	1.31	11.10
4 B 62 Q	6.55	5.80	6.20	J-2	Q1	2.69	1.31	0.63	0.28	0.19	2.50	1.75	12.60
4 B 64 P	6.75	6.00	6.40	J-2	P1	1.75	1.31	0.63	0.25	0.63	1.31	1.31	11.80
4 B 64 Q	6.75	6.00	6.40	J-2	Q1	2.69	1.31	0.63	0.28	0.19	2.50	1.75	14.10
4 B 66 P	6.95	6.20	6.60	J-2	P1	1.75	1.31	0.63	0.25	0.63	1.31	1.31	12.00
4 B 66 Q	6.95	6.20	6.60	J-2	Q1	2.69	1.31	0.63	0.28	0.19	2.50	1.75	14.80
4 B 68 P	7.15	6.40	6.80	J-2	P1	1.75	1.31	0.63	0.25	0.63	1.31	1.31	12.50
4 B 68 Q	7.15	6.40	6.80	J-2	Q1	2.69	1.31	0.63	0.28	0.19	2.50	1.75	16.90
4 B 70 Q	7.35	6.60	7.00	J-2	Q1	2.69	0.75	0.75	0.28	0.75	2.50	1.75	15.30
4 B 74 Q	7.75	7.00	7.40	J-2	Q1	2.69	0.75	0.75	0.28	0.75	1.75	1.75	15.30
4 B 80 Q	8.35	7.60	8.00	J-2	Q1	2.69	0.75	0.75	0.28	0.75	2.50	1.75	17.00
4 B 86 Q	8.95	8.20	8.60	J-2	P1	1.75	0.75	0.75	0.25	0.75	1.31	1.75	20.80
4 B 90 Q	9.35	8.60	9.00	J-3	Q1	2.69	0.75	0.75	0.28	0.75	2.50	1.75	20.60
4 B 94 Q	9.75	9.00	9.40	J-3	Q1	2.69	0.75	0.75	0.28	0.75	1.75	1.75	20.10
4 B 110 Q	11.35	10.60	11.00	J-3	Q1	2.69	0.75	0.75	0.28	0.75	1.75	1.75	25.80
4 B 124 Q	12.75	12.00	12.40	J-3	Q1	2.69	0.75	0.75	0.28	0.75	2.50	1.75	27.50
4 B 136 Q	13.95	13.20	13.60	J-3	Q1	2.69	0.75	0.75	0.28	0.75	1.75	1.75	31.50
4 B 154 Q	15.75	15.00	15.40	J-3	Q1	2.69	0.75	0.75	0.28	0.75	1.75	1.75	36.00
4 B 154 R	15.75	15.00	15.40	J-3	R1	3.75	0.75	0.88	0.28	0.50	2.88	2.00	40.10
4 B 160 Q	16.35	15.60	16.00	J-3	Q1	2.69	0.75	0.75	0.28	0.75	1.75	1.75	39.00
4 B 160 R	16.35	15.60	16.00	J-3	R1	3.75	0.75	0.88	0.28	0.50	2.88	2.00	44.00
4 B 184 Q	18.75	18.00	18.40	J-3	Q1	2.69	0.75	0.75	0.28	0.75	1.75	1.75	44.80
4 B 184 R	18.75	18.00	18.40	J-3	R1	3.75	0.75	0.88	0.28	0.50	2.88	2.00	50.30
4 B 200 Q	20.35	19.50	20.00	J-3	Q1	2.69	0.75	0.75	0.28	0.75	1.75	1.75	57.00
4 B 200 R	20.35	19.50	20.00	J-3	R1	3.75	0.75	0.88	0.28	0.50	2.88	2.00	54.00
4 B 250 Q	25.35	24.50	25.00	J-3	Q1	2.69	0.75	0.75	0.28	0.75	1.75	1.75	69.50
4 B 250 R	25.35	24.50	25.00	J-3	R1	3.75	0.75	0.88	0.28	0.50	2.88	2.00	71.00
4 B 300 Q	30.35	29.50	30.00	J-3	Q1	2.69	0.75	0.75	0.28	0.75	1.75	1.75	90.80
4 B 300 R	30.35	29.50	30.00	J-3	R1	3.75	0.75	0.88	0.28	0.50	2.88	2.00	99.00
4 B 380 Q	38.35	37.50	38.00	J-3	Q1	2.69	0.75	0.75	0.28	0.75	1.75	1.75	125.00
4 B 380 R	38.35	37.50	38.00	J-3	R1	3.75	0.75	0.88	0.28	0.50	2.88	2.00	126.00

NOTE: Dimensions in inches, weight in pounds. Weights do not include bushings 1 = Solid 2 = Web 3 = Spoked

PLEASE NOTE: Dashes are REQUIRED in place of spaces when ordering or searching on PTplace.com.

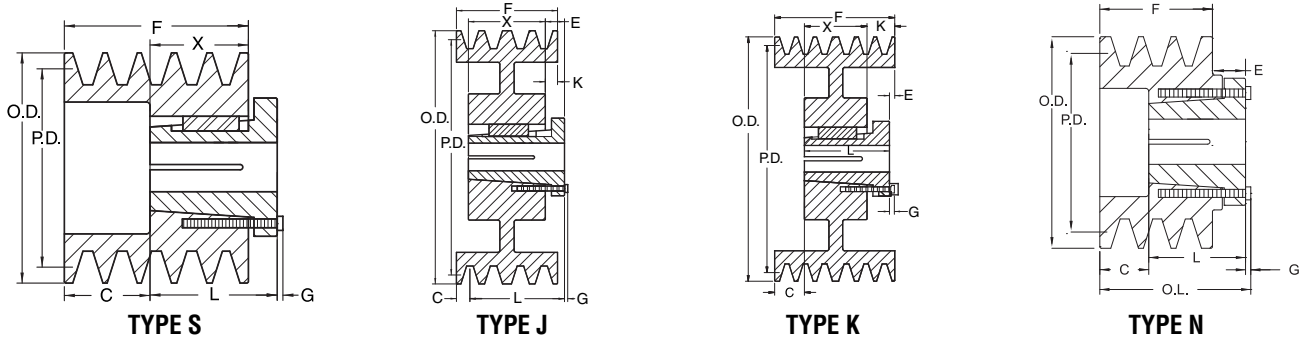

A-B MST Sheaves

Nomenclature Example: 5-B-34-P

5 Groove													
F = 4													
Part Number	OD	PD		Type	Bush	Bush Max. Bore	C	E	G	K	Length Thru Bore	X	Wt. Less Bushing
		A	B										
5 B 34 P	3.75	3.00	3.40	N-1	P2	1.75	2.13	0.63	0.25	0.44	2.31	2.31	5.30
5 B 36 P	3.95	3.20	3.60	G-1	P2	1.75	2.13	0.63	0.25	0.44	2.31	2.31	6.10
5 B 38 P	4.15	3.40	3.80	S-1	P2	1.75	1.69	—	0.25	—	2.31	2.31	6.10
5 B 40 P	4.35	3.60	4.00	S-1	P2	1.75	1.69	—	0.25	—	2.31	2.31	7.00
5 B 42 P	4.55	3.80	4.20	S-1	P2	1.75	1.69	—	0.25	—	2.31	2.31	7.80
5 B 44 P	4.75	4.00	4.40	J-2	P2	1.75	1.06	0.63	0.25	0.63	2.31	2.31	8.50
5 B 46 P	4.95	4.20	4.60	J-2	P2	1.75	1.06	0.63	0.25	0.63	2.31	2.31	9.80
5 B 48 P	5.15	4.40	4.80	J-2	P2	1.75	1.06	0.63	0.25	0.63	2.31	2.31	10.50
5 B 50 P	5.35	4.60	5.00	J-2	P2	1.75	1.06	0.63	0.25	0.63	2.31	2.31	11.60
5 B 52 P	5.55	4.80	5.20	J-2	P2	1.75	1.06	0.63	0.25	0.63	2.31	2.31	12.50
5 B 54 Q	5.75	5.00	5.40	J-2	Q1	2.69	1.50	0.75	0.28	0.75	1.75	1.75	10.40
5 B 56 Q	5.95	5.20	5.60	J-2	Q1	2.69	1.50	0.75	0.28	0.75	2.50	1.75	11.80
5 B 58 Q	6.15	5.40	5.80	J-2	Q1	2.69	1.50	0.75	0.28	0.75	1.75	1.75	12.80
5 B 60 Q	6.35	5.60	6.00	J-2	Q1	2.69	1.50	0.75	0.28	0.75	2.50	1.75	13.80
5 B 62 Q	6.55	5.80	6.20	J-2	Q1	2.69	1.50	0.75	0.28	0.75	1.75	1.75	14.60
5 B 64 Q	6.75	6.00	6.40	J-2	Q1	2.69	1.50	0.75	0.28	0.75	2.50	1.75	16.40
5 B 66 Q	6.95	6.20	6.60	J-2	Q1	2.69	1.50	0.75	0.28	0.75	1.75	1.75	17.10
5 B 68 Q	7.15	6.40	6.80	J-2	Q1	2.69	1.50	0.75	0.28	0.75	2.50	1.75	17.90
5 B 70 Q	7.35	6.60	7.00	J-2	Q2	2.63	0.63	0.75	0.28	0.63	2.75	2.75	20.90
5 B 70 R	7.35	6.60	7.00	J-2	R1	3.75	1.00	0.88	0.28	1.00	2.88	2.00	17.00
5 B 74 Q	7.75	7.00	7.40	J-2	Q2	2.63	0.63	0.75	0.28	0.63	2.75	2.75	19.80
5 B 74 R	7.75	7.00	7.40	J-2	R1	3.75	1.00	0.88	0.28	1.00	2.88	2.00	20.30
5 B 80 Q	8.35	7.60	8.00	J-2	Q2	2.63	0.63	0.75	0.28	0.63	2.75	2.75	22.30
5 B 80 R	8.35	7.60	8.00	J-2	R1	3.75	1.00	0.88	0.28	1.00	2.88	2.00	24.80
5 B 86 Q	8.95	8.20	8.60	J-2	Q2	2.63	0.63	0.75	0.28	0.63	2.75	2.75	29.50
5 B 86 R	8.95	8.20	8.60	J-2	R1	3.75	1.00	0.88	0.28	1.00	2.88	2.00	27.30
5 B 90 Q	9.35	8.60	9.00	J-3	Q2	2.63	0.63	0.75	0.28	0.63	2.75	2.75	28.60
5 B 90 R	9.35	8.60	9.00	J-2	R1	3.75	1.00	0.88	0.28	1.00	2.88	2.00	29.10
5 B 94 Q	9.75	9.00	9.40	J-3	Q2	2.63	0.63	0.75	0.28	0.63	2.75	2.75	29.50
5 B 94 R	9.75	9.00	9.40	J-2	R1	3.75	1.00	0.88	0.28	1.00	2.88	2.00	30.00
5 B 110 Q	11.35	10.60	11.00	J-3	Q2	2.63	0.63	0.75	0.28	0.63	2.75	2.75	32.80
5 B 110 R	11.35	10.60	11.00	K-3	R1	3.75	1.00	0.88	0.28	1.00	2.88	2.00	32.80
5 B 124 Q	12.75	12.00	12.40	J-3	Q2	2.63	0.63	0.75	0.28	0.63	2.75	2.75	35.40
5 B 124 R	12.75	12.00	12.40	K-3	R1	3.75	1.00	0.88	0.28	1.00	2.88	2.00	36.00
5 B 136 Q	13.95	13.20	13.60	J-3	Q2	2.63	0.63	0.75	0.28	0.63	2.75	2.75	41.00
5 B 136 R	13.95	13.20	13.60	K-3	R1	3.75	1.00	0.88	0.28	1.00	2.88	2.00	40.30
5 B 154 Q	15.75	15.00	15.40	J-3	Q2	2.63	0.63	0.75	0.28	0.63	2.75	2.75	45.30
5 B 154 R	15.75	15.00	15.40	K-3	R1	3.75	1.00	0.88	0.28	1.00	2.88	2.00	45.00
5 B 160 Q	16.35	15.60	16.00	J-3	Q2	2.63	0.63	0.75	0.28	0.63	2.75	2.75	48.00
5 B 160 R	16.35	15.60	16.00	K-3	R1	3.75	1.00	0.88	0.28	1.00	2.88	2.00	48.00
5 B 184 Q	18.75	18.00	18.40	J-3	Q2	2.63	0.63	0.75	0.28	0.63	2.75	2.75	57.30
5 B 184 R	18.75	18.00	18.40	K-3	R1	3.75	1.00	0.88	0.28	1.00	2.88	2.00	54.00
5 B 200 Q	20.35	19.50	20.00	J-3	Q2	2.63	0.63	0.75	0.28	0.63	2.75	2.75	66.00
5 B 200 R	20.35	19.50	20.00	K-3	R1	3.75	1.00	0.88	0.28	1.00	2.88	2.00	64.00
5 B 250 Q	25.35	24.50	25.00	J-3	Q2	2.63	0.63	0.75	0.28	0.63	2.75	2.75	82.50
5 B 250 R	25.35	24.50	25.00	K-3	R1	3.75	1.00	0.88	0.28	1.00	2.88	2.00	79.00
5 B 300 Q	30.35	29.50	30.00	J-3	Q2	2.63	0.63	0.75	0.28	0.63	2.75	2.75	117.00
5 B 300 R	30.35	29.50	30.00	K-3	R1	3.75	1.00	0.88	0.28	1.00	2.88	2.00	115.00
5 B 380 Q	38.35	37.50	38.00	J-3	Q2	2.63	0.63	0.75	0.28	0.63	2.75	2.75	159.00
5 B 380 R	38.35	37.50	38.00	K-3	R1	3.75	1.00	0.88	0.28	1.00	2.88	2.00	150.00

NOTE: Dimensions in inches, weight in pounds. Weights do not include bushings 1 = Solid 2 = Web 3 = Spoked

PLEASE NOTE: Dashes are REQUIRED in place of spaces when ordering or searching on PTplace.com.

V-Belt | MST® Sheaves

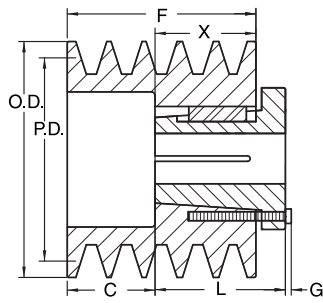

TYPE S

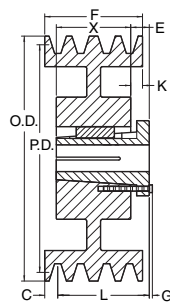

TYPE J

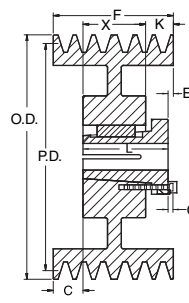

TYPE K

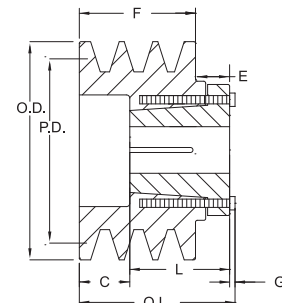

TYPE N

A-B MST Sheaves

Nomenclature Example: **6-B-34-P**

6 Groove													
F = 4-3/4													
Part Number	OD	PD		Type	Bush	Bush Max. Bore	C	E	G	K	Length Thru Bore	X	Wt. Less Bushing
		A	B										
6 B 34 P	3.75	3.00	3.40	N-1	P2	1.75	0.00	0.63	0.25	2.44	2.94	2.31	6.10
6 B 36 P	3.95	3.20	3.60	N-1	P2	1.75	2.88	0.63	0.25	0.44	2.31	2.31	7.30
6 B 38 P	4.15	3.40	3.80	S-1	P2	1.75	-	-	0.25	2.44	2.94	2.31	7.00
6 B 40 P	4.35	3.60	4.00	S-1	P2	1.75	-	-	0.25	2.44	2.94	2.31	8.10
6 B 42 P	4.55	3.80	4.20	S-1	P2	1.75	2.44	-	0.25	-	2.31	2.31	9.30
6 B 44 P	4.75	4.00	4.40	J-2	P2	1.75	-	0.63	0.25	2.44	2.94	2.31	9.90
6 B 46 P	4.95	4.20	4.60	J-2	P2	1.75	-	0.63	0.25	2.44	2.94	2.31	11.00
6 B 48 P	5.15	4.40	4.80	J-2	P2	1.75	1.81	0.63	0.25	0.63	2.31	2.31	11.80
6 B 50 P	5.35	4.60	5.00	J-2	P2	1.75	-	0.63	0.25	2.44	2.94	2.31	12.90
6 B 52 P	5.55	4.80	5.20	J-2	P2	1.75	1.81	0.63	0.25	0.63	2.31	2.31	14.80
6 B 54 Q	5.75	5.00	5.40	J-2	Q1	2.69	-	0.75	0.28	3.00	2.50	1.75	11.80
6 B 56 Q	5.95	5.20	5.60	J-2	Q1	2.69	2.25	0.75	0.28	0.75	1.75	1.75	17.30
6 B 58 Q	6.15	5.40	5.80	J-2	Q1	2.69	-	0.75	0.28	3.00	2.50	1.75	14.50
6 B 60 Q	6.35	5.60	6.00	J-2	Q1	2.69	-	0.75	0.28	3.00	2.50	1.75	15.40
6 B 62 Q	6.55	5.80	6.20	J-2	Q1	2.69	2.25	0.75	0.28	0.75	1.75	1.75	16.40
6 B 64 Q	6.75	6.00	6.40	J-2	Q1	2.69	-	0.75	0.28	3.00	2.50	1.75	18.60
6 B 66 Q	6.95	6.20	6.60	J-2	Q1	2.69	2.25	0.75	0.28	0.75	1.75	1.75	18.50
6 B 68 Q	7.15	6.40	6.80	J-2	Q1	2.69	-	0.75	0.28	3.00	2.50	1.75	20.80
6 B 70 Q	7.35	6.60	7.00	K-2	Q2	2.63	1.00	0.75	0.28	1.00	2.75	2.75	22.80
6 B 70 R	7.35	6.60	7.00	J-2	R1	3.75	-	0.88	0.28	2.75	2.88	2.00	19.00
6 B 74 Q	7.75	7.00	7.40	K-2	Q2	2.63	1.00	0.75	0.28	1.00	2.75	2.75	26.50
6 B 74 R	7.75	7.00	7.40	J-2	R1	3.75	-	0.88	0.28	2.75	2.88	2.00	21.80
6 B 80 Q	8.35	7.60	8.00	K-2	Q2	2.63	1.00	0.75	0.28	1.00	2.75	2.75	24.10
6 B 80 R	8.35	7.60	8.00	J-2	R1	3.75	-	0.88	0.28	2.75	2.88	2.00	26.80
6 B 86 Q	8.95	8.20	8.60	K-2	Q2	2.63	1.00	0.75	0.28	1.00	2.75	2.75	27.10
6 B 86 R	8.95	8.20	8.60	J-2	R1	3.75	-	0.88	0.28	2.75	2.88	2.00	29.40
6 B 90 Q	9.35	8.60	9.00	K-2	Q2	2.63	1.00	0.75	0.28	1.00	2.75	2.75	30.60
6 B 90 R	9.35	8.60	9.00	J-2	R1	3.75	-	0.88	0.28	2.75	2.88	2.00	31.40
6 B 94 Q	9.75	9.00	9.40	K-3	Q2	2.63	1.00	0.75	0.28	1.00	2.75	2.75	32.80
6 B 94 R	9.75	9.00	9.40	J-2	R1	3.75	-	0.88	0.28	2.75	2.88	2.00	32.80
6 B 110 Q	11.35	10.60	11.00	K-3	Q2	2.63	1.00	0.75	0.28	1.00	2.75	2.75	36.60
6 B 110 R	11.35	10.60	11.00	J-2	R1	3.75	-	0.88	0.28	2.75	2.88	2.00	37.00
6 B 124 Q	12.75	12.00	12.40	K-3	Q2	2.63	1.00	0.75	0.28	1.00	2.75	2.75	39.80
6 B 124 R	12.75	12.00	12.40	J-2	R1	3.75	-	0.88	0.28	2.75	2.88	2.00	39.40
6 B 136 Q	13.95	13.20	13.60	K-3	Q2	2.63	1.00	0.75	0.28	1.00	2.75	2.75	44.90
6 B 136 R	13.95	13.20	13.60	K-3	R1	3.75	-	0.88	0.28	2.75	2.88	2.00	45.30
6 B 154 Q	15.75	15.00	15.40	K-3	Q2	2.63	1.00	0.75	0.28	1.00	2.75	2.75	49.90
6 B 154 R	15.75	15.00	15.40	K-3	R1	3.75	-	0.88	0.28	2.75	2.88	2.00	49.10
6 B 160 Q	16.35	15.60	16.00	K-3	Q2	2.63	1.00	0.75	0.28	1.00	2.75	2.75	54.00
6 B 160 R	16.35	15.60	16.00	K-3	R1	3.75	-	0.88	0.28	2.75	2.88	2.00	52.00
6 B 184 Q	18.75	18.00	18.40	K-3	Q2	2.63	1.00	0.75	0.28	1.00	2.75	2.75	62.00
6 B 184 R	18.75	18.00	18.40	K-3	R1	3.75	-	0.88	0.28	2.75	2.88	2.00	59.00
6 B 200 Q	20.35	19.50	20.00	K-3	Q2	2.63	1.00	0.75	0.28	1.00	2.75	2.75	74.00
6 B 200 R	20.35	19.50	20.00	K-3	R1	3.75	-	0.88	0.28	2.75	2.88	2.00	69.00
6 B 250 Q	25.35	24.50	25.00	K-3	Q2	2.63	1.00	0.75	0.28	1.00	2.75	2.75	89.50
6 B 250 R	25.35	24.50	25.00	K-3	R1	3.75	-	0.88	0.28	2.75	2.88	2.00	83.00
6 B 300 Q	30.35	29.50	30.00	K-3	Q2	2.63	1.00	0.75	0.28	1.00	2.75	2.75	128.00
6 B 300 R	30.35	29.50	30.00	K-3	R1	3.75	-	0.88	0.28	2.75	2.88	2.00	126.00
6 B 380 Q	38.35	37.50	38.00	K-3	Q2	2.63	1.00	0.75	0.28	1.00	2.75	2.75	179.00
6 B 380 R	38.35	37.50	38.00	K-3	R1	3.75	-	0.88	0.28	2.75	2.88	2.00	170.00

NOTE: Dimensions in inches, weight in pounds. Weights do not include bushings

1 = Solid

2 = Web

3 = Spoked

PLEASE NOTE: Dashes are REQUIRED in place of spaces when ordering or searching on PTplace.com.

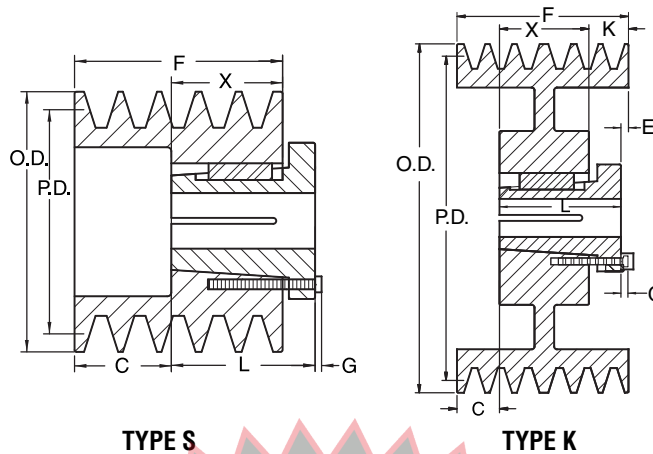

A-B MST Sheaves

Nomenclature Example: **8-B-54-Q**

8 Groove												
F = 6-1/4												
Part Number	OD	PD		Type	Bush	Bush Max. Bore	E	G	K	Length Thru Bore	X	Wt. Less Bushing
		A	B									
8 B 54 Q	5.75	5.00	5.40	S-1	Q2	2.63	0.75	0.28	3.50	3.50	2.75	18.10
8 B 56 Q	5.95	5.20	5.60	S-1	Q2	2.63	0.75	0.28	3.50	3.50	2.75	20.60
8 B 58 Q	6.15	5.40	5.80	K-2	Q2	2.63	0.75	0.28	3.50	3.50	2.75	20.90
8 B 60 Q	6.35	5.60	6.00	K-2	Q2	2.63	0.75	0.28	3.50	3.50	2.75	23.00
8 B 62 Q	6.55	5.80	6.20	K-2	Q2	2.63	0.75	0.28	3.50	3.50	2.75	23.00
8 B 64 Q	6.55	5.80	6.20	K-2	Q2	2.63	0.75	0.28	3.50	3.50	2.75	25.00
8 B 66 Q	6.95	6.20	6.60	K-2	Q2	2.63	0.75	0.28	3.50	3.50	2.75	27.30
8 B 68 Q	7.15	6.40	6.80	K-2	Q2	2.63	0.75	0.28	3.50	3.50	2.75	31.10
8 B 70 R	7.35	6.60	7.00	K-2	R2	3.63	0.88	0.28	2.25	4.88	4.00	29.50
8 B 74 R	7.75	7.00	7.40	K-2	R2	3.63	0.88	0.28	2.25	4.88	4.00	34.90
8 B 80 R	8.35	7.60	8.00	K-2	R2	3.63	0.88	0.28	2.25	4.88	4.00	42.90
8 B 86 R	8.95	8.20	8.60	K-2	R2	3.63	0.88	0.28	2.25	4.88	4.00	52.00
8 B 90 R	9.35	8.60	9.00	K-2	R2	3.63	0.88	0.28	2.25	4.88	4.00	48.30
8 B 94 R	9.75	9.00	9.40	K-2	R2	3.63	0.88	0.28	2.25	4.88	4.00	49.30
8 B 110 R	11.35	10.60	11.00	K-2	R2	3.63	0.88	0.28	2.25	4.88	4.00	55.00
8 B 124 R	12.75	12.00	12.40	K-3	R2	3.63	0.88	0.28	2.25	4.88	4.00	60.00
8 B 136 R	13.95	13.20	13.60	K-3	R2	3.63	0.88	0.28	2.25	4.88	4.00	68.50
8 B 154 R	15.75	15.00	15.40	K-3	R2	3.63	0.88	0.28	2.25	4.88	4.00	77.30
8 B 184 R	18.75	18.00	18.40	K-3	R2	3.63	0.88	0.28	2.25	4.88	4.00	90.00
8 B 200 R	20.35	19.50	20.00	K-3	R2	3.63	0.88	0.28	2.25	4.88	4.00	96.00
8 B 250 R	25.35	24.50	25.00	K-3	R2	3.63	0.88	0.28	2.25	4.88	4.00	129.00
8 B 300 R	30.35	29.50	30.00	K-3	R2	3.63	0.88	0.28	2.25	4.88	4.00	163.00
8 B 300 S	30.35	29.50	30.00	K-3	S1	4.25	1.06	0.38	2.94	4.38	3.31	168.00
8 B 380 R	38.35	37.50	38.00	K-3	R2	3.63	0.88	0.28	2.25	4.88	4.00	228.00
8 B 380 S	38.35	37.50	38.00	K-3	S1	4.25	1.06	0.38	2.94	4.38	3.31	238.00

NOTE: Dimensions in inches, weight in pounds. Weights do not include bushings

1 = Solid

2 = Web

3 = Spoked

PLEASE NOTE: Dashes are REQUIRED in place of spaces when ordering or searching on PTplace.com.

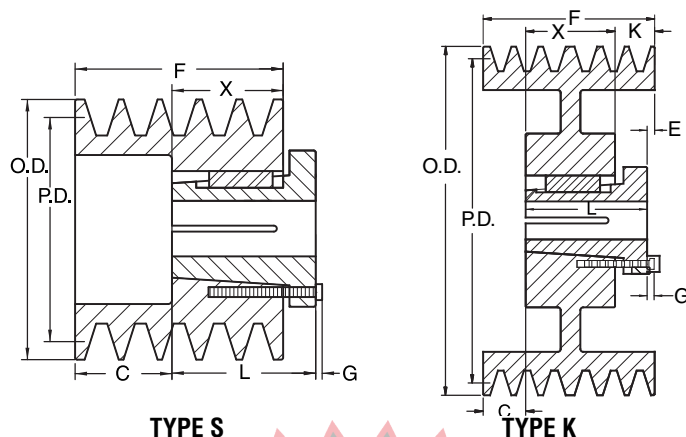

A-B MST Sheaves

Nomenclature Example: **10-B-54-Q**

10 Groove												
F = 7-3/4												
Part Number	OD	PD		Type	Bush	Bush Max. Bore	E	G	K	Length Thru Bore	X	Wt. Less Bushing
		A	B									
10 B 54 Q	5.75	5.00	5.40	S-1	Q2	2.63	0.75	0.28	5.00	3.50	2.75	21.50
10 B 56 Q	5.95	5.20	5.60	S-1	Q2	2.63	0.75	0.28	5.00	3.50	2.75	24.90
10 B 58 Q	6.15	5.40	5.80	K-2	Q2	2.63	0.75	0.28	5.00	3.50	2.75	23.50
10 B 60 Q	6.35	5.60	6.00	K-2	Q2	2.63	0.75	0.28	5.00	3.50	2.75	25.60
10 B 62 Q	6.55	5.80	6.20	K-2	Q2	2.63	0.75	0.28	5.00	3.50	2.75	27.50
10 B 64 Q	6.75	6.00	6.40	K-2	Q2	2.63	0.75	0.28	5.00	3.50	2.75	31.40
10 B 66 Q	6.95	6.20	6.60	K-2	Q2	2.63	0.75	0.28	5.00	3.50	2.75	32.50
10 B 68 Q	7.15	6.40	6.80	K-2	Q2	2.63	0.75	0.28	5.00	3.50	2.75	36.10
10 B 70 R	7.35	6.60	7.00	K-2	R2	3.63	0.88	0.28	3.75	4.88	4.00	34.00
10 B 74 R	7.75	7.00	7.40	K-2	R2	3.63	0.88	0.28	3.75	4.88	4.00	39.30
10 B 80 R	8.35	7.60	8.00	K-2	R2	3.63	0.88	0.28	3.75	4.88	4.00	48.50
10 B 86 R	8.95	8.20	8.60	K-2	R2	3.63	0.88	0.28	3.75	4.88	4.00	51.50
10 B 90 R	9.35	8.60	9.00	K-2	R2	3.63	0.88	0.28	3.75	4.88	4.00	52.30
10 B 94 R	9.75	9.00	9.40	K-2	R2	3.63	0.88	0.28	3.75	4.88	4.00	54.00
10 B 110 R	11.35	10.60	11.00	K-2	R2	3.63	0.88	0.28	3.75	4.88	4.00	61.00
10 B 124 R	12.75	12.00	12.40	K-2	R2	3.63	0.88	0.28	3.75	4.88	4.00	77.50
10 B 136 R	13.95	13.20	13.60	K-2	R2	3.63	0.88	0.28	3.75	4.88	4.00	76.50
10 B 154 R	15.75	15.00	15.40	K-3	R2	3.63	0.88	0.28	3.75	4.88	4.00	89.00
10 B 184 R	18.75	18.00	18.40	K-3	R2	3.63	0.88	0.28	3.75	4.88	4.00	104.00
10 B 200 R	20.35	19.50	20.00	K-3	R2	3.63	0.88	0.28	3.75	4.88	4.00	112.00
10 B 250 R	25.35	24.50	25.00	K-3	R2	3.63	0.88	0.28	3.75	4.88	4.00	153.00
10 B 300 R	30.35	29.50	30.00	K-3	R2	3.63	0.88	0.28	3.75	4.88	4.00	188.00
10 B 380 R	38.35	37.50	38.00	K-3	R2	3.63	0.88	0.28	3.75	4.88	4.00	258.00
10 B 380 U	38.35	37.50	38.00	K-3	U0	5.50	1.19	0.47	4.00	4.94	3.75	270.00

NOTE: Dimensions in inches, weight in pounds. Weights do not include bushings

1 = Solid

2 = Web

3 = Spoked

PLEASE NOTE: Dashes are REQUIRED in place of spaces when ordering or searching on PTplace.com.

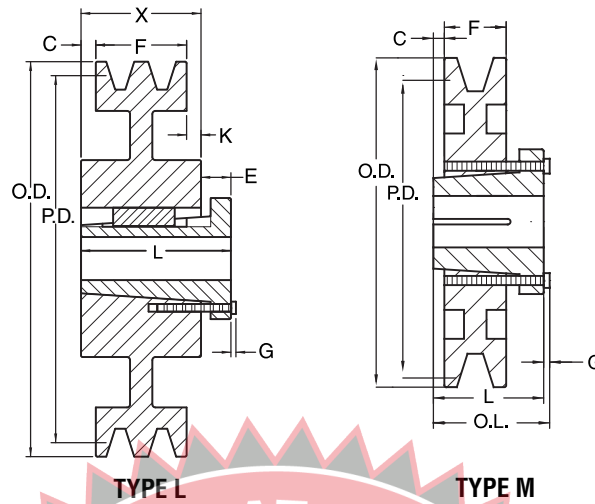

C MST Sheaves

Nomenclature Example: 1-C-56-P

1 Groove												
F = 1-1/4												
Part Number	OD	PD C	Type	Bush	Bush Max. Bore	C	E	G	K	Length Thru Bore	X	Wt. Less Bushing
1 C 56 P	6.00	5.60	M-1	P1	1.75	0.06	0.63	0.25	-	1.94	1.31	6.00
1 C 60 Q	6.40	6.00	M-1	Q1	2.69	0.50	0.75	0.28	-	2.50	1.75	6.10
1 C 70 Q	7.40	7.00	M-1	Q1	2.69	0.50	0.75	0.28	-	2.50	1.25	9.30
1 C 72 Q	7.60	7.20	M-2	Q1	2.69	0.50	0.75	0.28	-	2.50	1.25	10.10
1 C 74 Q	7.80	7.40	M-2	Q1	2.69	0.50	0.75	0.28	-	2.50	1.25	10.80
1 C 76 Q	8.00	7.60	M-2	Q1	2.69	0.50	0.75	0.28	-	2.50	1.25	11.40
1 C 78 Q	8.20	7.80	M-2	Q1	2.69	0.50	0.75	0.28	-	2.50	1.25	9.80
1 C 80 Q	8.40	8.00	M-2	Q1	2.69	0.50	0.75	0.28	-	2.50	1.25	9.90
1 C 82 Q	8.60	8.20	M-2	Q1	2.69	0.50	0.75	0.28	-	2.50	1.25	10.10
1 C 84 Q	8.80	8.40	M-2	Q1	2.69	0.50	0.75	0.28	-	2.50	1.25	11.00
1 C 86 Q	9.00	8.60	M-2	Q1	2.69	0.50	0.75	0.28	-	2.50	1.25	10.60
1 C 88 Q	9.20	8.80	M-2	Q1	2.69	0.50	0.75	0.28	-	2.50	1.25	11.60
1 C 90 Q	9.40	9.00	M-2	Q1	2.69	0.50	0.75	0.28	-	2.50	1.25	11.40
1 C 92 Q	9.60	9.20	M-2	Q1	2.69	0.50	0.75	0.28	-	2.50	1.25	12.60
1 C 94 Q	9.80	9.40	L-3	Q1	2.69	0.25	0.75	0.28	1.00	2.50	1.75	14.80
1 C 96 Q	10.00	9.60	L-3	Q1	2.69	0.25	0.75	0.28	1.00	2.50	1.75	15.80
1 C 98 Q	10.20	9.80	L-3	Q1	2.69	0.25	0.75	0.28	1.00	2.50	1.75	15.90
1 C 100 Q	10.40	10.00	L-3	Q1	2.69	0.25	0.75	0.28	1.00	2.50	1.75	16.80
1 C 102 Q	10.60	10.20	L-3	Q1	2.69	0.25	0.75	0.28	1.00	2.50	1.75	16.10
1 C 106 Q	11.00	10.60	L-3	Q1	2.69	0.25	0.75	0.28	1.00	2.50	1.75	17.30
1 C 110 Q	11.40	11.00	L-3	Q1	2.69	0.25	0.75	0.28	1.00	2.50	1.75	17.50
1 C 114 Q	11.80	11.40	L-3	Q1	2.69	0.25	0.75	0.28	1.00	2.50	1.75	18.60
1 C 120 Q	12.40	12.00	L-3	Q1	2.69	0.25	0.75	0.28	1.00	2.50	1.75	19.50
1 C 130 Q	13.40	13.00	L-3	Q1	2.69	0.25	0.75	0.28	1.00	2.50	1.75	22.80
1 C 160 Q	16.40	16.00	L-3	Q1	2.69	0.25	0.75	0.28	1.00	2.50	1.75	28.50
1 C 200 Q	20.40	20.00	L-3	Q1	2.69	0.25	0.75	0.28	1.00	2.50	1.75	37.80
1 C 240 Q	24.40	24.00	L-3	Q1	2.69	0.25	0.75	0.28	1.00	2.50	1.75	49.50

NOTE: Dimensions in inches, weight in pounds. Weights do not include bushings 1 = Solid 2 = Web 3 = Spoked

PLEASE NOTE: Dashes are REQUIRED in place of spaces when ordering or searching on PTplace.com.

V-Belt | MST® Sheaves

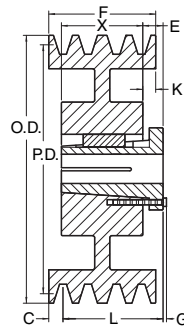

TYPE J

C MST Sheaves

Nomenclature Example: **2-C-56-P**

2 Groove												
F = 2-1/4												
Part Number	OD	PD C	Type	Bush	Bush Max. Bore	C	E	G	K	Length Thru Bore	X	Wt. Less Bushing
2 C 56 P	6.00	5.60	J-2	P1	1.75	0.31	0.63	0.25	0.63	1.94	1.31	8.40
2 C 60 Q	6.40	6.00	J-2	Q1	2.69	0.00	0.75	0.28	0.50	2.50	1.75	9.50
2 C 70 Q	7.40	7.00	J-2	Q1	2.69	0.25	0.75	0.28	0.25	2.50	1.75	14.00
2 C 72 Q	7.60	7.20	J-2	Q1	2.69	0.25	0.75	0.28	0.25	2.50	1.75	15.40
2 C 74 Q	7.80	7.40	J-2	Q1	2.69	0.25	0.75	0.28	0.25	2.50	1.75	16.60
2 C 76 Q	8.00	7.60	J-2	Q1	2.69	0.25	0.75	0.28	0.25	2.50	1.75	17.60
2 C 78 Q	8.20	7.80	J-2	Q1	2.69	0.25	0.75	0.28	0.25	2.50	1.75	14.10
2 C 80 Q	8.40	8.00	J-2	Q1	2.69	0.25	0.75	0.28	0.25	2.50	1.75	14.30
2 C 82 Q	8.60	8.20	J-2	Q1	2.69	0.25	0.75	0.28	0.25	2.50	1.75	14.80
2 C 84 Q	8.80	8.40	J-2	Q1	2.69	0.25	0.75	0.28	0.25	2.50	1.75	16.40
2 C 86 Q	9.00	8.60	J-2	Q1	2.69	0.25	0.75	0.28	0.25	2.50	1.75	16.10
2 C 88 Q	9.20	8.80	J-2	Q1	2.69	0.25	0.75	0.28	0.25	2.50	1.75	17.10
2 C 90 Q	9.40	9.00	J-2	Q1	2.69	0.25	0.75	0.28	0.25	2.50	1.75	16.80
2 C 92 Q	9.60	9.20	J-2	Q1	2.69	0.25	0.75	0.28	0.25	2.50	1.75	18.40
2 C 94 Q	9.80	9.40	J-3	Q1	2.69	0.25	0.75	0.28	0.25	2.50	1.75	19.10
2 C 96 Q	10.00	9.60	J-3	Q1	2.69	0.25	0.75	0.28	0.25	2.50	1.75	20.60
2 C 98 Q	10.20	9.80	J-3	Q1	2.69	0.25	0.75	0.28	0.25	2.50	1.75	19.50
2 C 100 Q	10.40	10.00	J-3	Q1	2.69	0.25	0.75	0.28	0.25	2.50	1.75	22.00
2 C 102 Q	10.60	10.20	J-3	Q1	2.69	0.25	0.75	0.28	0.25	2.50	1.75	21.30
2 C 106 Q	11.00	10.60	J-3	Q1	2.69	0.25	0.75	0.28	0.25	2.50	1.75	22.40
2 C 110 Q	11.40	11.00	J-3	Q1	2.69	0.25	0.75	0.28	0.25	2.50	1.75	22.40
2 C 114 Q	11.80	11.40	J-3	Q1	2.69	0.25	0.75	0.28	0.25	2.50	1.75	23.50
2 C 120 Q	12.40	12.00	J-3	Q1	2.69	0.25	0.75	0.28	0.25	2.50	1.75	24.90
2 C 130 Q	13.40	13.00	J-3	Q1	2.69	0.25	0.75	0.28	0.25	2.50	1.75	28.60
2 C 140 R	14.40	14.00	J-3	R1	3.75	0.13	0.88	0.28	0.13	2.88	2.00	33.50
2 C 160 Q	16.40	16.00	J-3	Q1	2.69	0.25	0.75	0.28	0.25	2.50	1.75	36.00
2 C 180 R	18.40	18.00	J-3	R1	3.75	0.13	0.88	0.28	0.13	2.88	2.00	42.30
2 C 200 Q	20.40	20.00	J-3	Q1	2.69	0.25	0.75	0.28	0.25	2.50	1.75	46.00
2 C 240 Q	24.40	24.00	J-3	Q1	2.69	0.25	0.75	0.28	0.25	2.50	1.75	59.50
2 C 270 R	27.40	27.00	J-3	R1	3.75	0.13	0.88	0.28	0.13	2.88	2.00	77.00
2 C 300 R	30.40	30.00	J-3	R1	3.75	0.13	0.88	0.28	0.13	2.88	2.00	93.00
2 C 360 R	36.40	36.00	J-3	R1	3.75	0.13	0.88	0.28	0.13	2.88	2.00	117.00
2 C 440 R	44.40	44.00	J-3	R1	3.75	0.13	0.88	0.28	0.13	2.88	2.00	164.00

NOTE: Dimensions in inches, weight in pounds. Weights do not include bushings 1 = Solid 2 = Web 3 = Spoked

PLEASE NOTE: Dashes are REQUIRED in place of spaces when ordering or searching on PTplace.com.

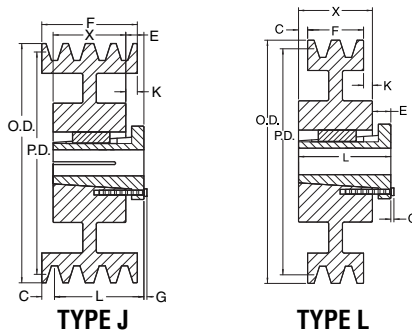

C MST Sheaves

Nomenclature Example: 3-C-50-Q

3 Groove												
F = 3-1/4												
Part Number	OD	PD C	Type	Bush	Bush Max. Bore	C	E	G	K	Length Thru Bore	X	Wt. Less Bushing
3 C 50 Q	5.40	5.00	J-1	Q1	2.69	1.50	0.75	0.28	-	2.50	1.75	8.40
3 C 56 P	6.00	5.60	J-2	P2	1.75	0.31	0.63	0.25	0.63	2.94	2.31	12.90
3 C 60 Q	6.40	6.00	J-2	Q1	2.69	0.63	0.75	0.28	0.75	2.50	1.75	11.80
3 C 70 Q	7.40	7.00	J-2	Q1	2.69	0.63	0.75	0.28	0.75	2.50	1.75	16.80
3 C 72 Q	7.60	7.20	J-2	Q1	2.69	0.63	0.75	0.28	0.75	2.50	1.75	18.00
3 C 74 Q	7.80	7.40	J-2	Q1	2.69	0.63	0.75	0.28	0.75	2.50	1.75	19.10
3 C 76 Q	8.00	7.60	J-2	Q1	2.69	0.63	0.75	0.28	0.75	2.50	1.75	21.30
3 C 78 Q	8.20	7.80	J-2	Q1	2.69	0.63	0.75	0.28	0.75	2.50	1.75	17.40
3 C 80 Q	8.40	8.00	J-2	Q1	2.69	0.63	0.75	0.28	0.75	2.50	1.75	17.80
3 C 82 Q	8.60	8.20	J-2	Q1	2.69	0.63	0.75	0.28	0.75	2.50	1.75	17.90
3 C 84 Q	8.80	8.40	J-2	Q1	2.69	0.63	0.75	0.28	0.75	2.50	1.75	20.40
3 C 86 Q	9.00	8.60	J-2	Q1	2.69	0.63	0.75	0.28	0.75	2.50	1.75	19.50
3 C 88 Q	9.20	8.80	J-2	Q1	2.69	0.63	0.75	0.28	0.75	2.50	1.75	22.50
3 C 90 R	9.40	9.00	J-2	R1	3.75	0.63	0.88	0.28	0.75	2.88	2.00	27.30
3 C 90 Q	9.40	9.00	J-2	Q1	2.69	0.75	0.75	0.28	0.75	2.50	1.75	20.40
3 C 92 R	9.60	9.20	J-2	R1	3.75	0.63	0.88	0.28	0.75	2.88	2.00	27.50
3 C 92 Q	9.60	9.20	J-2	Q1	2.69	0.75	0.75	0.28	0.75	2.50	1.75	22.80
3 C 94 R	9.80	9.40	J-3	R1	3.75	0.63	0.88	0.28	0.75	2.88	2.00	26.90
3 C 94 Q	9.80	9.40	J-3	Q1	2.69	0.75	0.75	0.28	0.75	2.50	1.75	23.00
3 C 96 R	10.00	9.60	J-3	R1	3.75	0.63	0.88	0.28	0.75	2.88	2.00	28.40
3 C 96 Q	10.00	9.60	J-3	Q1	2.69	0.75	0.75	0.28	0.75	2.50	1.75	25.30
3 C 98 R	10.20	9.80	J-3	R1	3.75	0.63	0.88	0.28	0.75	2.88	2.00	29.30
3 C 98 Q	10.20	9.80	J-3	Q1	2.69	0.75	0.75	0.28	0.75	2.50	1.75	24.40
3 C 100 R	10.40	10.00	J-2	R1	3.75	0.63	0.88	0.28	0.63	2.88	2.00	29.00
3 C 100 Q	10.40	10.00	J-3	Q1	2.69	0.75	0.75	0.28	0.75	2.50	1.75	27.60
3 C 102 R	10.60	10.20	J-2	R1	3.75	0.63	0.88	0.28	0.63	2.88	2.00	31.40
3 C 102 Q	10.60	10.20	J-3	Q1	2.69	0.75	0.75	0.28	0.75	2.50	1.75	24.90
3 C 106 R	11.00	10.60	J-2	R1	3.75	0.63	0.88	0.28	0.63	2.88	2.00	31.80
3 C 106 Q	11.00	10.60	J-3	Q1	2.69	0.75	0.75	0.28	0.75	2.50	1.75	26.90
3 C 110 R	11.40	11.00	J-2	R1	3.75	0.63	0.88	0.28	0.63	2.88	2.00	29.30
3 C 110 Q	11.40	11.00	J-3	Q1	2.69	0.75	0.75	0.28	0.75	2.50	1.75	27.40
3 C 114 Q	11.80	11.40	J-3	Q1	2.69	0.75	0.75	0.28	0.75	2.50	1.75	28.30
3 C 120 R	12.40	12.00	J-2	R1	3.75	0.63	0.88	0.28	0.63	2.88	2.00	36.90
3 C 120 Q	12.40	12.00	J-3	Q1	2.69	0.75	0.75	0.28	0.75	2.50	1.75	30.30
3 C 130 R	13.40	13.00	J-3	R1	3.75	0.63	0.88	0.28	0.63	2.88	2.00	34.80
3 C 130 Q	13.40	13.00	J-3	Q1	2.69	0.75	0.75	0.28	0.75	2.50	1.75	34.90
3 C 140 R	14.40	14.00	J-3	R1	3.75	0.63	0.88	0.28	0.63	2.88	2.00	39.40
3 C 150 R	15.40	15.00	J-3	R1	3.75	0.63	0.88	0.28	0.63	2.88	2.00	43.80
3 C 160 R	16.40	16.00	J-3	R1	3.75	0.63	0.88	0.28	0.63	2.88	2.00	47.00
3 C 160 Q	16.40	16.00	J-3	Q1	2.69	0.75	0.75	0.28	0.75	2.50	1.75	46.00
3 C 180 R	18.40	18.00	J-3	R1	3.75	0.63	0.88	0.28	0.63	2.88	2.00	51.50
3 C 200 R	20.40	20.00	J-3	R1	3.75	0.63	0.88	0.28	0.63	2.88	2.00	58.00
3 C 200 Q	20.40	20.00	J-3	Q1	2.69	0.75	0.75	0.28	0.75	2.50	1.75	54.50
3 C 240 R	24.40	24.00	J-3	R1	3.75	0.63	0.88	0.28	0.63	2.88	2.00	71.00
3 C 240 Q	24.40	24.00	J-3	Q1	2.69	0.75	0.75	0.28	0.75	2.50	1.75	71.00
3 C 270 R	27.40	27.00	J-3	R1	3.75	0.63	0.88	0.28	0.63	2.88	2.00	92.00
3 C 300 R	30.40	30.00	J-3	R1	3.75	0.63	0.88	0.28	0.63	2.88	2.00	110.00
3 C 360 R	36.40	36.00	J-3	R1	3.75	0.63	0.88	0.28	0.63	2.88	2.00	135.00
3 C 440 R	44.40	44.00	J-3	R1	3.75	0.63	0.88	0.28	0.63	2.88	2.00	196.00
3 C 500 R	50.40	50.00	J-3	R1	3.75	0.63	0.88	0.28	0.63	2.88	2.00	213.00
3 C 500 S	50.40	50.00	L-3	S1	4.25	0.03	1.06	0.38	0.03	4.38	3.31	224.00

NOTE: Dimensions in inches, weight in pounds. Weights do not include bushings 1 = Solid 2 = Web 3 = Spoked

PLEASE NOTE: Dashes are REQUIRED in place of spaces when ordering or searching on PTplace.com.

C MST Sheaves

Nomenclature Example: **4-C-50-Q**

4 Groove												
F = 4-1/4												
Part Number	OD	PD C	Type	Bush	Bush Max. Bore	C	E	G	K	Length Thru Bore	X	Wt. Less Bushing
4 C 50 Q	5.40	5.00	J-1	Q2	2.63	1.50	2.75	0.28	—	3.50	2.75	10.90
4 C 56 P	6.00	5.60	J-2	P2	1.75	1.31	0.63	0.25	0.63	2.94	2.31	15.40
4 C 60 Q	6.40	6.00	J-2	Q2	2.63	0.75	2.75	0.28	0.88	3.50	2.75	17.00
4 C 70 Q	7.40	7.00	J-2	Q2	2.63	0.75	0.75	0.28	0.75	3.50	2.75	23.80
4 C 72 Q	7.60	7.20	J-2	Q2	2.63	0.75	0.75	0.28	0.75	3.50	2.75	26.80
4 C 74 Q	7.80	7.40	J-2	Q2	2.63	0.75	0.75	0.28	0.75	3.50	2.75	27.50
4 C 76 Q	8.00	7.60	J-2	Q2	2.63	0.75	0.75	0.28	0.75	3.50	2.75	30.30
4 C 78 Q	8.20	7.80	J-2	Q2	2.63	0.75	0.75	0.28	0.75	3.50	2.75	26.40
4 C 80 Q	8.40	8.00	J-2	Q2	2.63	0.75	0.75	0.28	0.75	3.50	2.75	29.00
4 C 82 Q	8.60	8.20	J-2	Q2	2.63	0.75	0.75	0.28	0.75	3.50	2.75	26.80
4 C 84 Q	8.80	8.40	J-2	Q2	2.63	0.75	0.75	0.28	0.75	3.50	2.75	28.80
4 C 86 Q	9.00	8.60	J-2	Q2	2.63	0.75	0.75	0.28	0.75	3.50	2.75	27.90
4 C 88 Q	9.20	8.80	J-2	Q2	2.63	0.75	0.75	0.28	0.75	3.50	2.75	31.60
4 C 90 R	9.40	9.00	K-2	R1	3.75	1.13	0.88	0.28	1.13	2.88	2.00	30.00
4 C 90 Q	9.40	9.00	J-2	Q2	2.63	0.75	0.75	0.28	0.75	3.50	2.75	28.40
4 C 92 R	9.60	9.20	K-2	R1	3.75	1.13	0.88	0.28	1.13	2.88	2.00	31.60
4 C 92 Q	9.60	9.20	J-2	Q2	2.63	0.75	0.75	0.28	0.75	3.50	2.75	32.30
4 C 94 R	9.80	9.40	K-2	R1	3.75	1.13	0.88	0.28	1.13	2.88	2.00	31.60
4 C 94 Q	9.80	9.40	J-2	Q2	2.63	0.75	0.75	0.28	0.75	3.50	2.75	31.80
4 C 96 R	10.00	9.60	K-2	R1	3.75	1.13	0.88	0.28	1.13	2.88	2.00	31.10
4 C 96 Q	10.00	9.60	J-2	Q2	2.63	0.75	0.75	0.28	0.75	3.50	2.75	35.20
4 C 98 R	10.20	9.80	K-2	R1	3.75	1.13	0.88	0.28	1.13	2.88	2.00	33.40
4 C 98 Q	10.20	9.80	J-2	Q2	2.63	0.75	0.75	0.28	0.75	3.50	2.75	33.00
4 C 100 R	10.40	10.00	K-2	R1	3.75	1.13	0.88	0.28	1.13	2.88	2.00	34.10
4 C 100 Q	10.40	10.00	J-3	Q2	2.63	0.75	0.75	0.28	0.75	3.50	2.75	37.00
4 C 102 R	10.60	10.20	K-2	R1	3.75	1.13	0.88	0.28	1.13	2.88	2.00	36.50
4 C 102 Q	10.60	10.20	J-3	Q2	2.63	0.75	0.88	0.28	0.75	3.50	2.75	33.50
4 C 106 R	11.00	10.60	K-2	R1	3.75	1.13	0.88	0.28	1.13	2.88	2.00	36.50
4 C 106 Q	11.00	10.60	J-3	Q2	2.63	0.75	0.88	0.28	0.75	3.50	2.75	36.30
4 C 110 R	11.40	11.00	K-2	R1	3.75	1.13	0.88	0.28	1.13	2.88	2.00	33.00
4 C 110 Q	11.40	11.00	J-3	Q2	2.63	0.75	0.88	0.28	0.75	3.50	2.75	36.30
4 C 114 Q	11.80	11.40	J-3	Q2	2.63	0.75	0.75	0.28	0.75	3.50	2.75	38.40
4 C 120 R	12.40	12.00	K-2	R1	3.75	1.13	0.88	0.28	1.13	2.88	2.00	42.90
4 C 120 Q	12.40	12.00	J-3	Q2	2.63	0.75	0.88	0.28	0.75	3.50	2.75	40.50
4 C 130 R	13.40	13.00	K-3	R1	3.75	1.13	0.88	0.28	1.13	2.88	2.00	40.10
4 C 130 Q	13.40	13.00	J-3	Q2	2.63	0.75	0.88	0.28	0.75	3.50	2.75	43.60
4 C 140 R	14.40	14.00	K-3	R1	3.75	1.13	0.88	0.28	1.13	2.88	2.00	46.60
4 C 150 R	15.40	15.00	K-3	R1	3.75	1.13	0.88	0.28	1.13	2.88	2.00	52.00
4 C 160 R	16.40	16.00	K-3	R1	3.75	1.13	0.88	0.28	1.13	2.88	2.00	55.00
4 C 160 Q	16.40	16.00	J-3	Q2	2.63	0.75	0.88	0.28	0.75	3.50	2.75	55.00
4 C 180 R	18.40	18.00	K-3	R1	3.75	1.13	0.88	0.28	1.13	2.88	2.00	60.00
4 C 180 S	18.40	18.00	J-3	S1	4.25	0.47	1.06	0.38	0.47	4.38	3.31	92.00
4 C 200 R	20.40	20.00	K-3	R1	3.75	1.13	0.88	0.28	1.13	2.88	2.00	69.00
4 C 200 S	20.40	20.00	J-3	S1	4.25	0.47	1.06	0.38	0.47	4.38	3.31	103.00
4 C 200 Q	20.40	20.00	J-3	Q2	2.63	0.75	1.06	0.28	0.75	3.50	2.75	103.00
4 C 240 R	24.40	24.00	K-3	R1	3.75	1.13	0.88	0.28	1.13	2.88	2.00	86.00
4 C 240 S	24.40	24.00	J-3	S1	4.25	0.47	1.06	0.38	0.47	4.38	3.31	120.00
4 C 240 Q	24.40	24.00	J-3	Q2	2.63	0.75	1.06	0.28	0.75	3.50	2.75	120.00
4 C 270 R	27.40	27.00	K-3	R1	3.75	1.13	0.88	0.28	1.13	2.88	2.00	110.00
4 C 270 S	27.40	27.00	J-3	S1	4.25	0.47	1.06	0.38	0.47	4.38	3.31	123.00
4 C 300 R	30.40	30.00	K-3	R1	3.75	1.13	0.88	0.28	1.13	2.88	2.00	123.00
4 C 300 S	30.40	30.00	J-3	S1	4.25	0.47	1.06	0.38	0.47	4.38	3.31	142.00
4 C 360 R	36.40	36.00	K-3	R1	3.75	1.13	0.88	0.28	1.13	2.88	2.00	156.00
4 C 360 S	36.40	36.00	J-3	S1	4.25	0.47	1.06	0.38	0.47	4.38	3.31	183.00
4 C 440 R	44.40	44.00	K-3	R1	3.75	1.13	0.88	0.28	1.13	2.88	2.00	218.00
4 C 440 U	44.40	44.00	J-3	U0	5.50	0.25	1.19	0.47	0.25	4.94	3.75	241.00
4 C 500 R	50.40	50.00	K-3	R1	3.75	1.13	0.88	0.28	1.13	2.88	2.00	240.00
4 C 500 U	50.40	50.00	J-3	U0	5.50	0.25	1.19	0.47	0.25	4.94	3.75	283.00

NOTE: Dimensions in inches, weight in pounds. Weights do not include bushings

1 = Solid

2 = Web

3 = Spoked

PLEASE NOTE: Dashes are REQUIRED in place of spaces when ordering or searching on PTplace.com.

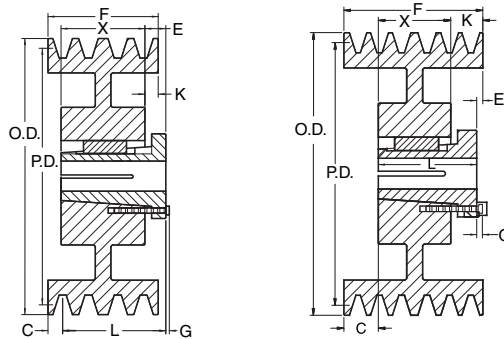

C MST Sheaves

TYPE J

TYPE K

Nomenclature Example: 5-C-70-Q

5 Groove												
F = 5-1/4												
Part Number	OD	PD C	Type	Bush	Bush Max. Bore	C	E	G	K	Length Thru Bore	X	Wt. Less Bushing
5 C 70 Q	7.40	7.00	K-2	Q2	2.63	1.25	0.75	0.28	1.25	3.50	2.75	27.50
5 C 72 Q	7.60	7.20	K-2	Q2	2.63	1.25	0.75	0.28	1.25	3.50	2.75	29.80
5 C 74 Q	7.80	7.40	K-2	Q2	2.63	1.25	0.75	0.28	1.25	3.50	2.75	31.00
5 C 76 Q	8.00	7.60	K-2	Q2	2.63	1.25	0.75	0.28	1.25	3.50	2.75	34.30
5 C 78 Q	8.20	7.80	K-2	Q2	2.63	1.25	0.75	0.28	1.25	3.50	2.75	30.00
5 C 80 Q	8.40	8.00	K-2	Q2	2.63	1.25	0.75	0.28	1.25	3.50	2.75	33.40
5 C 82 Q	8.60	8.20	K-2	Q2	2.63	1.25	0.75	0.28	1.25	3.50	2.75	30.30
5 C 84 Q	8.80	8.40	K-2	Q2	2.63	1.25	0.75	0.28	1.25	3.50	2.75	32.80
5 C 86 Q	9.00	8.60	K-2	Q2	2.63	1.25	0.75	0.28	1.25	3.50	2.75	31.00
5 C 88 Q	9.20	8.80	K-2	Q2	2.63	1.25	0.75	0.28	1.25	3.50	2.75	34.90
5 C 90 R	9.40	9.00	K-2	R1	3.75	1.63	0.88	0.28	1.63	2.88	2.00	33.40
5 C 90 Q	9.40	9.00	K-2	Q2	2.63	1.25	0.75	0.28	1.25	3.50	2.75	32.60
5 C 92 R	9.60	9.20	K-2	R1	3.75	1.63	0.88	0.28	1.63	2.88	2.00	36.80
5 C 92 Q	9.60	9.20	K-2	Q2	2.63	1.25	0.75	0.28	1.25	3.50	2.75	36.40
5 C 94 R	9.80	9.40	K-2	R1	3.75	1.63	0.88	0.28	1.63	2.88	2.00	35.80
5 C 94 Q	9.80	9.40	K-3	Q2	2.63	1.25	0.75	0.28	1.25	3.50	2.75	35.60
5 C 96 R	10.00	9.60	K-2	R1	3.75	1.63	0.88	0.28	1.63	2.88	2.00	35.40
5 C 96 Q	10.00	9.60	K-3	Q2	2.63	1.25	0.75	0.28	1.25	3.50	2.75	39.10
5 C 98 R	10.20	9.80	K-2	R1	3.75	1.63	0.88	0.28	1.63	2.88	2.00	37.60
5 C 98 Q	10.20	9.80	K-3	Q2	2.63	1.25	0.75	0.28	1.25	3.50	2.75	37.30
5 C 100 R	10.40	10.00	K-2	R1	3.75	1.63	0.88	0.28	1.63	2.88	2.00	38.90
5 C 100 Q	10.40	10.00	K-3	Q2	2.63	1.25	0.75	0.28	1.25	3.50	2.75	42.30
5 C 102 R	10.60	10.20	K-2	R1	3.75	1.63	0.88	0.28	1.63	2.88	2.00	40.60
5 C 102 Q	10.60	10.20	K-3	Q2	2.63	1.25	0.75	0.28	1.25	3.50	2.75	39.40
5 C 106 R	11.00	10.60	K-2	R1	3.75	1.63	0.88	0.28	1.63	2.88	2.00	39.00
5 C 106 Q	11.00	10.60	K-3	Q2	2.63	1.25	0.75	0.28	1.25	3.50	2.75	41.00
5 C 110 R	11.40	11.00	K-2	R1	3.75	1.63	0.88	0.28	1.63	2.88	2.00	38.80
5 C 110 Q	11.40	11.00	K-3	Q2	2.63	1.25	0.75	0.28	1.25	3.50	2.75	42.40
5 C 114 Q	11.80	11.40	K-3	Q2	2.63	1.25	0.75	0.28	1.25	3.50	2.75	42.80
5 C 120 R	12.40	12.00	K-2	R1	3.75	1.63	0.88	0.28	1.63	2.88	2.00	47.50
5 C 120 Q	12.40	12.00	K-3	Q2	2.63	1.25	0.75	0.28	1.25	3.50	2.75	46.30
5 C 130 R	13.40	13.00	K-3	R1	3.75	1.63	0.88	0.28	1.63	2.88	2.00	46.00
5 C 130 Q	13.40	13.00	K-3	Q2	2.63	1.25	0.75	0.28	1.25	3.50	2.75	49.50
5 C 140 R	14.40	14.00	K-3	R1	3.75	1.63	0.88	0.28	1.63	2.88	2.00	52.00
5 C 150 R	15.40	15.00	K-3	R1	3.75	1.63	0.88	0.28	1.63	2.88	2.00	54.00
5 C 160 R	16.40	16.00	K-3	R1	3.75	1.63	0.88	0.28	1.63	2.88	2.00	63.00
5 C 160 Q	16.40	16.00	K-3	Q2	2.63	1.25	0.75	0.28	1.25	3.50	2.75	64.50
5 C 180 R	18.40	18.00	K-3	R1	3.75	1.63	0.88	0.28	1.63	2.88	2.00	69.00
5 C 180 S	18.40	18.00	J-3	S1	4.25	0.97	1.06	0.38	0.97	4.38	3.31	100.00
5 C 200 R	20.40	20.00	K-3	R1	3.75	0.63	0.88	0.28	2.63	2.88	2.00	77.00
5 C 200 S	20.40	20.00	J-3	S1	4.25	0.97	1.06	0.38	0.97	4.38	3.31	99.00
5 C 200 Q	20.40	20.00	K-3	Q2	2.63	1.25	0.75	0.28	1.25	3.50	2.75	78.00
5 C 240 R	24.40	24.00	K-3	R1	3.75	0.63	0.88	0.28	2.63	2.88	2.00	110.00
5 C 240 S	24.40	24.00	J-3	S1	4.25	0.97	1.06	0.38	0.97	4.38	3.31	129.00
5 C 240 Q	24.40	24.00	K-3	Q2	2.63	1.25	0.75	0.28	1.25	3.50	2.75	96.00
5 C 270 R	27.40	27.00	J-3	R2	3.63	0.63	0.88	0.28	0.63	4.88	4.00	131.00
5 C 300 R	30.40	30.00	J-3	R2	3.63	0.63	0.88	0.28	0.63	4.88	4.00	150.00
5 C 300 S	30.40	30.00	J-3	S1	4.25	0.97	1.06	0.38	0.97	4.38	3.31	160.00
5 C 360 R	36.40	36.00	J-3	R2	3.63	0.63	0.88	0.28	0.63	4.88	4.00	194.00
5 C 440 R	44.40	44.00	J-3	R2	3.63	0.63	0.88	0.28	0.63	4.88	4.00	243.00
5 C 500 R	50.40	50.00	J-3	R2	3.63	0.63	0.88	0.28	0.63	4.88	4.00	273.00

NOTE: Dimensions in inches, weight in pounds. Weights do not include bushings

1 = Solid

2 = Web

3 = Spoked

PLEASE NOTE: Dashes are REQUIRED in place of spaces when ordering or searching on PTplace.com.

C MST Sheaves

Nomenclature Example: **6-C-70-Q**

6 Groove												
F = 6-1/4												
Part Number	OD	PD	Type	Bush	Bush Max. Bore	C	E	G	K	Length Thru Bore	X	Wt. Less Bushing
		C										
6 C 70 Q	7.40	7.00	K-2	Q2	2.63	1.75	0.75	0.28	1.75	3.50	2.75	29.90
6 C 72 Q	7.60	7.20	K-2	Q2	2.63	1.75	0.75	0.28	1.75	3.50	2.75	33.60
6 C 74 Q	7.80	7.40	K-2	Q2	2.63	1.75	0.75	0.28	1.75	3.50	2.75	33.30
6 C 76 Q	8.00	7.60	K-2	Q2	2.63	1.75	0.75	0.28	1.75	3.50	2.75	37.90
6 C 78 Q	8.20	7.80	K-2	Q2	2.63	1.75	0.75	0.28	1.75	3.50	2.75	33.50
6 C 80 Q	8.40	8.00	K-2	Q2	2.63	1.75	0.75	0.28	1.75	3.50	2.75	37.60
6 C 82 Q	8.60	8.20	K-2	Q2	2.63	1.75	0.75	0.28	1.75	3.50	2.75	34.00
6 C 84 Q	8.80	8.40	K-2	Q2	2.63	1.75	0.75	0.28	1.75	3.50	2.75	37.00
6 C 86 Q	9.00	8.60	K-2	Q2	2.63	1.75	0.75	0.28	1.75	3.50	2.75	35.00
6 C 88 Q	9.20	8.80	K-2	Q2	2.63	1.75	0.75	0.28	1.75	3.50	2.75	39.40
6 C 90 R	9.40	9.00	K-2	R2	3.63	1.13	0.88	0.28	1.13	4.88	4.00	53.00
6 C 90 Q	9.40	9.00	K-2	Q2	2.63	1.75	0.75	0.28	1.75	3.50	2.75	36.80
6 C 92 R	9.60	9.20	K-2	R2	3.63	1.13	0.88	0.28	1.13	4.88	4.00	58.00
6 C 92 Q	9.60	9.20	K-2	Q2	2.63	1.75	0.75	0.28	1.75	3.50	2.75	41.00
6 C 94 R	9.80	9.40	K-2	R2	3.63	1.13	0.88	0.28	1.13	4.88	4.00	63.50
6 C 94 Q	9.80	9.40	K-3	Q2	2.63	1.75	0.75	0.28	1.75	3.50	2.75	39.40
6 C 96 R	10.00	9.60	K-2	R2	3.63	1.13	0.88	0.28	1.13	4.88	4.00	55.00
6 C 96 Q	10.00	9.60	K-3	Q2	2.63	1.75	0.75	0.28	1.75	3.50	2.75	43.60
6 C 98 R	10.20	9.80	K-2	R2	3.63	1.13	0.88	0.28	1.13	4.88	4.00	65.00
6 C 98 Q	10.20	9.80	K-3	Q2	2.63	1.75	0.75	0.28	1.75	3.50	2.75	42.00
6 C 100 R	10.40	10.00	K-2	R2	3.63	1.13	0.88	0.28	1.13	4.88	4.00	62.00
6 C 100 Q	10.40	10.00	K-3	Q2	2.63	1.75	0.75	0.28	1.75	3.50	2.75	47.30
6 C 102 R	10.60	10.20	K-2	R2	3.63	1.13	0.88	0.28	1.13	4.88	4.00	68.00
6 C 102 Q	10.60	10.20	K-3	Q2	2.63	1.75	0.75	0.28	1.75	3.50	2.75	44.40
6 C 106 R	11.00	10.60	K-2	R2	3.63	1.13	0.88	0.28	1.13	4.88	4.00	55.00
6 C 106 Q	11.00	10.60	K-3	Q2	2.63	1.75	0.75	0.28	1.75	3.50	2.75	45.40
6 C 110 R	11.40	11.00	K-2	R2	3.63	1.13	0.88	0.28	1.13	4.88	4.00	51.50
6 C 110 Q	11.40	11.00	K-3	Q2	2.63	1.75	0.75	0.28	1.75	3.50	2.75	47.00
6 C 114 Q	11.80	11.40	K-3	Q2	2.63	1.75	0.75	0.28	1.75	3.50	2.75	49.60
6 C 120 R	12.40	12.00	K-2	R2	3.63	1.13	0.88	0.28	1.13	4.88	4.00	64.00
6 C 120 Q	12.40	12.00	K-3	Q2	2.63	1.75	0.75	0.28	1.75	3.50	2.75	51.00
6 C 130 R	13.40	13.00	K-3	R2	3.63	1.13	0.88	0.28	1.13	4.88	4.00	61.00
6 C 130 Q	13.40	13.00	K-3	Q2	2.63	1.75	0.75	0.28	1.75	3.50	2.75	56.00
6 C 140 R	14.40	14.00	K-3	R2	3.63	1.13	0.88	0.28	1.13	4.88	4.00	69.00
6 C 150 R	15.40	15.00	K-3	R2	3.63	1.13	0.88	0.28	1.13	4.88	4.00	68.00
6 C 160 R	16.40	16.00	K-3	R2	3.63	1.13	0.88	0.28	1.13	4.88	4.00	77.00
6 C 160 Q	16.40	16.00	K-3	Q2	2.63	1.75	0.75	0.28	1.75	3.50	2.75	72.00
6 C 180 R	18.40	18.00	K-3	R2	3.63	1.13	0.88	0.28	1.13	4.88	4.00	84.00
6 C 180 S	18.40	18.00	K-3	S1	4.25	1.47	1.06	0.28	1.47	4.38	3.31	107.00
6 C 200 R	20.40	20.00	K-3	R2	3.63	1.13	0.88	0.28	1.13	4.88	4.00	91.50
6 C 200 S	20.40	20.00	K-3	S1	4.25	1.47	1.06	0.38	1.47	4.38	3.31	127.00
6 C 200 Q	20.40	20.00	K-3	Q2	2.63	1.75	0.75	0.28	1.75	3.50	2.75	88.30
6 C 240 R	24.40	24.00	K-3	R2	3.63	1.13	0.88	0.28	1.13	4.88	4.00	116.00
6 C 240 S	24.40	24.00	K-3	S1	4.25	1.47	1.06	0.38	1.47	4.38	3.31	125.00
6 C 240 Q	24.40	24.00	K-3	Q2	2.63	1.75	0.75	0.28	1.75	3.50	2.75	108.00
6 C 270 R	27.40	27.00	K-3	R2	3.63	1.13	0.88	0.28	1.13	4.88	4.00	144.00
6 C 270 S	27.40	27.00	K-3	S1	4.25	1.47	1.06	0.38	1.47	4.38	3.31	151.00
6 C 300 R	30.40	30.00	K-3	R2	3.63	1.13	0.88	0.28	1.13	4.88	4.00	160.00
6 C 300 U	30.40	30.00	K-3	U0	5.50	1.25	1.19	0.47	1.25	4.94	3.75	191.00
6 C 360 R	36.40	36.00	K-3	R2	3.63	1.13	0.88	0.28	1.13	4.88	4.00	211.00
6 C 360 U	36.40	36.00	K-3	U0	5.50	1.25	1.19	0.47	1.25	4.94	3.75	233.00
6 C 440 R	44.40	44.00	K-3	R2	3.63	1.13	0.88	0.28	1.13	4.88	4.00	286.00
6 C 500 R	50.40	50.00	K-3	R2	3.63	1.13	0.88	0.28	1.13	4.88	4.00	303.00

NOTE: Dimensions in inches, weight in pounds. Weights do not include bushings

1 = Solid

2 = Web

3 = Spoked

PLEASE NOTE: Dashes are REQUIRED in place of spaces when ordering or searching on PTplace.com.

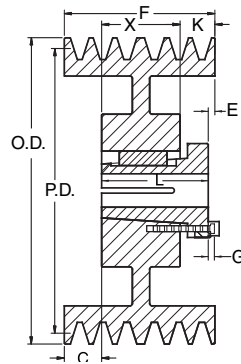

TYPE K

C MST Sheaves

Nomenclature Example: 7-C-70-Q

7 Groove												
F = 7-1/4												
Part Number	OD	PD	Type	Bush	Bush Max Bore	C	E	G	K	Length Thru Bore	X	Wt. Less Bushing
		C										
7 C 70 Q	7.40	7.00	K-2	Q3	2.500	1.500	0.750	0.281	1.500	5.000	0.000	37.50
7 C 80 R	8.40	8.00	K-2	R2	3.625	1.625	0.875	0.281	1.625	4.875	4.000	45.60
7 C 86 R	9.00	8.60	K-2	R2	3.625	1.625	0.875	0.281	1.625	4.875	4.000	52.80
7 C 90 R	9.40	9.00	K-2	R2	3.625	1.625	0.875	0.281	1.625	4.875	4.000	58.00
7 C 92 R	9.60	9.20	K-2	R2	3.625	1.625	0.875	0.281	1.625	4.875	4.000	63.00
7 C 94 R	9.80	9.40	K-2	R2	3.625	1.625	0.875	0.281	1.625	4.875	4.000	68.00
7 C 98 R	10.20	9.80	K-2	R2	3.625	1.625	0.875	0.281	1.625	4.875	4.000	73.00
7 C 100 R	10.40	10.00	K-2	R2	3.625	1.625	0.875	0.281	1.625	4.875	4.000	71.00
7 C 102 R	10.60	10.20	K-2	R2	3.625	1.625	0.875	0.281	1.625	4.875	4.000	76.00
7 C 106 R	11.00	10.60	K-2	R2	3.625	1.625	0.875	0.281	1.625	4.875	4.000	71.00
7 C 110 R	11.40	11.00	K-2	R2	3.625	1.625	0.875	0.281	1.625	4.875	4.000	68.00
7 C 120 R	12.40	12.00	K-2	R2	3.625	1.625	0.875	0.281	1.625	4.875	4.000	67.00
7 C 130 R	13.40	13.00	K-3	R2	3.625	1.625	0.875	0.281	1.625	4.875	4.000	84.00
7 C 140 R	14.40	14.00	K-3	R2	3.625	1.625	0.875	0.281	1.625	4.875	4.000	83.00
7 C 150 R	15.40	15.00	K-3	R2	3.625	1.625	0.875	0.281	1.625	4.875	4.000	86.00
7 C 160 R	16.40	16.00	K-3	R2	3.625	1.625	0.875	0.281	1.625	4.875	4.000	88.00
7 C 180 S	18.40	18.00	J-3	S2	4.188	0.781	1.062	0.375	1.281	6.750	5.688	137.00
7 C 180 U	18.40	18.00	K-3	U0	5.500	1.750	1.188	0.468	1.750	4.938	3.750	133.00
7 C 200 S	20.40	20.00	J-3	S2	4.188	0.781	1.062	0.375	1.281	6.750	5.688	152.00
7 C 200 U	20.40	20.00	K-3	U0	5.500	1.750	1.188	0.468	1.750	4.938	3.750	144.00
7 C 240 S	24.40	24.00	J-3	S2	4.188	0.781	1.062	0.375	1.281	6.750	5.688	173.00
7 C 270 S	27.40	27.00	J-3	S2	4.188	0.781	1.062	0.375	1.281	6.750	5.688	197.00
7 C 270 U	27.40	27.00	K-3	U0	5.500	1.750	1.188	0.468	1.750	4.938	3.750	196.00
7 C 300 S	30.40	30.00	J-3	S2	4.188	0.781	1.062	0.375	1.281	6.750	5.688	220.00
7 C 300 U	30.40	30.00	K-3	U0	5.500	1.750	1.188	0.468	1.750	4.938	3.750	217.00
7 C 360 S	36.40	36.00	J-3	S2	4.188	0.781	1.062	0.375	1.281	6.750	5.688	279.00
7 C 440 S	44.40	44.00	J-3	S2	4.188	0.781	1.062	0.375	1.281	6.750	5.688	337.00
7 C 500 S	50.40	50.00	J-3	S2	4.188	0.781	1.062	0.375	1.281	6.750	5.688	382.00

NOTE: Dimensions in inches, weight in pounds. Weights do not include bushings 1 = Solid 2 = Web 3 = Spoked

PLEASE NOTE: Dashes are REQUIRED in place of spaces when ordering or searching on PTplace.com.

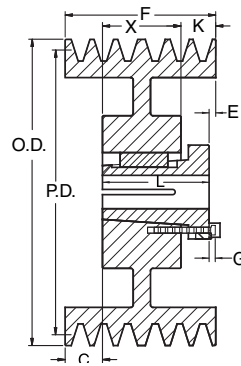

TYPE K

C MST Sheaves

Nomenclature Example: **8-C-70-Q**

8 Groove												
F = 8-1/4												
Part Number	OD	PD C	Type	Bush	Bush Max. Bore	C	E	G	K	Length Thru Bore	X	Wt. Less Bushing
8 C 70 Q	7.40	7.00	K-2	Q3	2.50	1.63	0.75	0.28	2.38	5.00	0.00	40.00
8 C 80 R	8.40	8.00	K-2	R2	3.63	1.63	0.88	0.28	2.63	4.88	4.00	49.00
8 C 86 R	9.00	8.60	K-2	R2	3.63	1.63	0.88	0.28	2.63	4.88	4.00	57.00
8 C 90 R	9.40	9.00	K-2	R2	3.63	1.63	0.88	0.28	2.63	4.88	4.00	62.00
8 C 92 R	9.60	9.20	K-2	R2	3.63	1.63	0.88	0.28	2.63	4.88	4.00	68.00
8 C 94 R	9.80	9.40	K-2	R2	3.63	1.63	0.88	0.28	2.63	4.88	4.00	73.00
8 C 96 R	10.00	9.60	K-2	R2	3.63	1.63	0.88	0.28	2.63	4.88	4.00	70.00
8 C 98 R	10.20	9.80	K-2	R2	3.63	1.63	0.88	0.28	2.63	4.88	4.00	76.00
8 C 100 R	10.40	10.00	K-2	R2	3.63	1.63	0.88	0.28	2.63	4.88	4.00	72.00
8 C 102 R	10.60	10.20	K-2	R2	3.63	1.63	0.88	0.28	2.63	4.88	4.00	79.00
8 C 106 R	11.00	10.60	K-2	R2	3.63	1.63	0.88	0.28	2.63	4.88	4.00	76.00
8 C 110 R	11.40	11.00	K-2	R2	3.63	2.13	0.88	0.28	2.13	4.88	4.00	73.00
8 C 120 R	12.40	12.00	K-2	R2	3.63	2.13	0.88	0.28	2.13	4.88	4.00	74.00
8 C 130 R	13.40	13.00	K-3	R2	3.63	2.13	0.88	0.28	2.13	4.88	4.00	80.00
8 C 140 R	14.40	14.00	K-3	R2	3.63	2.13	0.88	0.28	2.13	4.88	4.00	84.00
8 C 150 R	15.40	15.00	K-3	R2	3.63	2.13	0.88	0.28	2.13	4.88	4.00	93.00
8 C 160 R	16.40	16.00	K-3	R2	3.63	2.13	0.88	0.28	2.13	4.88	4.00	100.00
8 C 180 S	18.40	18.00	K-3	S2	4.19	1.28	1.06	0.38	1.28	6.75	5.69	140.00
8 C 180 U	18.40	18.00	K-3	U0	5.50	2.25	1.19	0.47	2.25	4.94	3.75	141.00
8 C 200 S	20.40	20.00	K-3	S2	4.19	1.28	1.06	0.38	1.28	6.75	5.69	163.00
8 C 200 U	20.40	20.00	K-3	U0	5.50	2.25	1.19	0.47	2.25	4.94	3.75	160.00
8 C 240 S	24.40	24.00	K-3	S2	4.19	1.28	1.06	0.38	1.28	6.75	5.69	194.00
8 C 240 U	24.40	24.00	K-3	U0	5.50	2.25	1.19	0.47	2.25	4.94	3.75	184.00
8 C 270 S	27.40	27.00	K-3	S2	4.19	1.28	1.06	0.38	1.28	6.75	5.69	224.00
8 C 300 S	30.40	30.00	K-3	S2	4.19	1.28	1.06	0.38	1.28	6.75	5.69	212.00
8 C 300 U	30.40	30.00	K-3	U0	5.50	2.25	1.19	0.47	2.25	4.94	3.75	227.00
8 C 360 S	36.40	36.00	K-3	S2	4.19	1.28	1.06	0.38	1.28	6.75	5.69	261.00
8 C 360 U	36.40	36.00	K-3	U0	5.50	2.25	1.19	0.47	2.25	4.94	3.75	288.00
8 C 440 S	44.40	44.00	K-3	S2	4.19	1.28	1.06	0.38	1.28	6.75	5.69	368.00
8 C 440 U	44.40	44.00	K-3	U0	5.50	2.25	1.19	0.47	2.25	4.94	3.75	358.00
8 C 500 S	50.40	50.00	K-3	S2	4.19	1.28	1.06	0.38	1.28	6.75	5.69	429.00
8 C 500 U	50.40	50.00	K-3	U0	5.50	2.25	1.19	0.47	2.25	4.94	3.75	417.00

NOTE: Dimensions in inches, weight in pounds. Weights do not include bushings

1 = Solid

2 = Web

3 = Spoked

PLEASE NOTE: Dashes are REQUIRED in place of spaces when ordering or searching on PTplace.com.

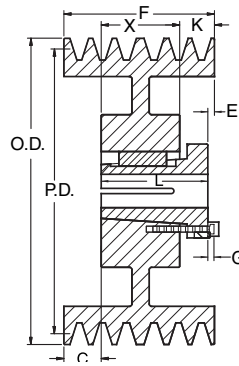

TYPE K

C MST Sheaves

Nomenclature Example: 10-C-80-R

10 Groove												
F = 10-1/4												
Part Number	OD	PD C	Type	Bush	Bush Max. Bore	C	E	G	K	Length Thru Bore	X	Wt. Less Bushing
10 C 80 R	8.40	8.00	K-2	R2	3.63	1.63	0.88	0.28	4.63	4.88	4.00	70.00
10 C 86 R	9.00	8.60	K-2	R2	3.63	1.63	0.88	0.28	4.63	4.88	4.00	72.00
10 C 90 R	9.40	9.00	K-2	R2	3.63	1.63	0.88	0.28	4.63	4.88	4.00	72.00
10 C 92 R	9.60	9.20	K-2	R2	3.63	1.63	0.88	0.28	4.63	4.88	4.00	70.00
10 C 94 R	9.80	9.40	K-2	R2	3.63	1.63	0.88	0.28	4.63	4.88	4.00	78.00
10 C 96 R	10.00	9.60	K-2	R2	3.63	1.63	0.88	0.28	4.63	4.88	4.00	73.00
10 C 98 R	10.20	9.80	K-2	R2	3.63	1.63	0.88	0.28	4.63	4.88	4.00	88.00
10 C 100 R	10.40	10.00	K-2	R2	3.63	1.63	0.88	0.28	4.63	4.88	4.00	89.00
10 C 102 R	10.60	10.20	K-2	R2	3.63	1.63	0.88	0.28	4.63	4.88	4.00	97.00
10 C 106 R	11.00	10.60	K-2	R2	3.63	1.63	0.88	0.28	4.63	4.88	4.00	84.00
10 C 110 R	11.40	11.00	K-2	R2	3.63	3.13	0.88	0.28	4.63	4.88	4.00	84.00
10 C 120 R	12.40	12.00	K-2	R2	3.63	3.13	0.88	0.28	4.63	4.88	4.00	97.00
10 C 130 R	13.40	13.00	K-3	R2	3.63	3.13	0.88	0.28	4.63	4.88	4.00	102.00
10 C 140 R	14.40	14.00	K-3	R2	3.63	3.13	0.88	0.28	4.63	4.88	4.00	106.00
10 C 150 R	15.40	15.00	K-3	R2	3.63	3.13	0.88	0.28	4.63	4.88	4.00	110.00
10 C 160 R	16.40	16.00	K-3	R2	3.63	3.13	0.88	0.28	4.63	4.88	4.00	111.00
10 C 180 S	18.40	18.00	K-3	S2	4.19	2.28	1.06	0.38	2.28	6.75	5.69	164.00
10 C 180 U	18.40	18.00	K-3	U0	5.50	3.25	1.19	0.47	3.25	4.94	3.75	163.00
10 C 200 S	20.40	20.00	K-3	S2	4.19	2.28	1.06	0.38	2.28	6.75	5.69	170.00
10 C 200 U	20.40	20.00	K-3	U0	5.50	3.25	1.19	0.47	3.25	4.94	3.75	178.00
10 C 240 S	24.40	24.00	K-3	S2	4.19	2.28	1.06	0.38	2.28	6.75	5.69	210.00
10 C 240 U	24.40	24.00	K-3	U0	5.50	3.25	1.19	0.47	3.25	4.94	3.75	208.00
10 C 270 S	27.40	27.00	K-3	S2	4.19	2.28	1.06	0.38	2.28	6.75	5.69	246.00
10 C 300 S	30.40	30.00	K-3	S2	4.19	2.28	1.06	0.38	2.28	6.75	5.69	278.00
10 C 300 U	30.40	30.00	K-3	U1	5.50	2.31	1.50	0.47	2.31	7.13	5.63	298.00
10 C 360 S	36.40	36.00	K-3	S2	4.19	2.28	1.06	0.38	2.28	6.75	5.69	324.00
10 C 360 U	36.40	36.00	K-3	U1	5.50	2.31	1.50	0.47	2.31	7.13	5.63	362.00
10 C 440 U	44.40	44.00	K-3	U1	5.50	2.31	1.50	0.47	2.31	7.13	5.63	463.00
10 C 500 U	50.40	50.00	K-3	U1	5.50	2.31	1.50	0.47	2.31	7.13	5.63	480.00

NOTE: Dimensions in inches, weight in pounds. Weights do not include bushings 1 = Solid 2 = Web 3 = Spoked

PLEASE NOTE: Dashes are REQUIRED in place of spaces when ordering or searching on PTplace.com.

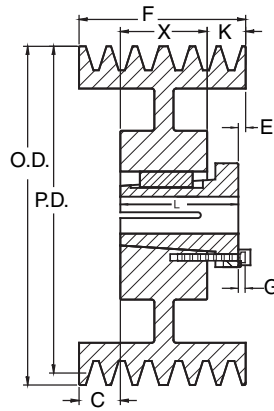

TYPE K

C MST Sheaves

Nomenclature Example: **12-C-90-S**

12 Groove												
F = 12-1/4												
Part Number	OD	PD	Type	Bush	Bush Max. Bore	C	E	G	K	Length Thru Bore	X	Wt. Less Bushing
		C										
12 C 90 S	9.40	9.00	K-2	S2	4.19	2.00	1.06	0.38	4.56	6.75	5.69	88.00
12 C 92 S	9.60	9.20	K-2	S2	4.19	2.00	1.06	0.38	4.56	6.75	5.69	93.00
12 C 94 S	9.80	9.40	K-2	S2	4.19	2.00	1.06	0.38	4.56	6.75	5.69	104.00
12 C 96 S	10.00	9.60	K-2	S2	4.19	2.00	1.06	0.38	4.56	6.75	5.69	102.00
12 C 98 S	10.20	9.80	K-2	S2	4.19	2.00	1.06	0.38	4.56	6.75	5.69	111.00
12 C 100 S	10.40	10.00	K-2	S2	4.19	2.00	1.06	0.38	4.56	6.75	5.69	112.00
12 C 102 S	10.60	10.20	K-2	S2	4.19	2.00	1.06	0.38	4.56	6.75	5.69	121.00
12 C 106 S	11.00	10.60	K-2	S2	4.19	2.00	1.06	0.38	4.56	6.75	5.69	133.00
12 C 110 S	11.40	11.00	K-2	S2	4.19	3.28	1.06	0.38	3.28	6.75	5.69	128.00
12 C 120 S	12.40	12.00	K-2	S2	4.19	3.28	1.06	0.38	3.28	6.75	5.69	140.00
12 C 130 S	13.40	13.00	K-2	S2	4.19	3.28	1.06	0.38	3.28	6.75	5.69	165.00
12 C 140 S	14.40	14.00	K-3	S2	4.19	3.28	1.06	0.38	3.28	6.75	5.69	148.00
12 C 150 S	15.40	15.00	K-3	S2	4.19	3.28	1.06	0.38	3.28	6.75	5.69	162.00
12 C 160 S	16.40	16.00	K-3	S2	4.19	3.28	1.06	0.38	3.28	6.75	5.69	163.00
12 C 180 U	18.40	18.00	K-3	U1	5.50	3.31	1.50	0.47	3.31	7.13	5.63	204.00
12 C 200 U	20.40	20.00	K-3	U1	5.50	3.31	1.50	0.47	3.31	7.13	5.63	224.00
12 C 240 U	24.40	24.00	K-3	U1	5.50	3.31	1.50	0.47	3.31	7.13	5.63	257.00
12 C 270 U	27.40	27.00	K-3	U1	5.50	3.31	1.50	0.47	3.31	7.13	5.63	300.00
12 C 300 U	30.40	30.00	K-3	U1	5.50	3.31	1.50	0.47	3.31	7.13	5.63	327.00
12 C 360 U	36.40	36.00	K-3	U1	5.50	3.31	1.50	0.47	3.31	7.13	5.63	397.00
12 C 440 U	44.40	44.00	K-3	U1	5.50	3.31	1.50	0.47	3.31	7.13	5.63	519.00
12 C 500 U	50.40	50.00	K-3	U1	5.50	3.31	1.50	0.47	3.31	7.13	5.63	551.00

NOTE: Dimensions in inches, weight in pounds. Weights do not include bushings

1 = Solid

2 = Web

3 = Spoked

PLEASE NOTE: Dashes are REQUIRED in place of spaces when ordering or searching on PTplace.com.

All Steel QD Bushings

★F = Length of Mating Bore

★★G = Gap Between QD Bushing and Mating Hub

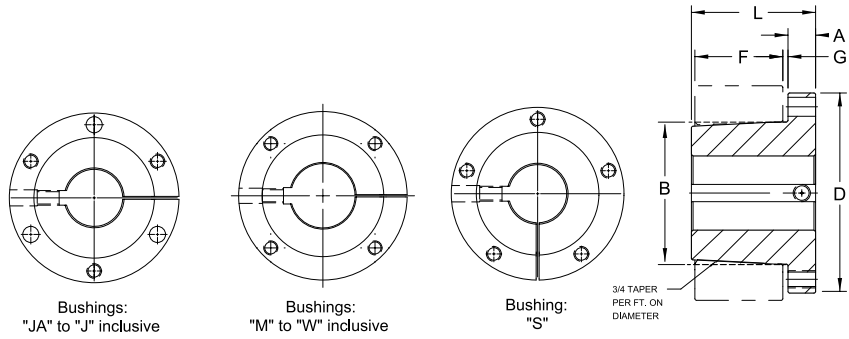

Bushing	Dimensions (Inches)								Screws Required	Stock Bore Range			Average Weight (Approx.)
	A	B	D	E	★F	★★G	L	Cap Bolt Circle		Min.	Maximum		
											Standard Keyway	Shallow Keyway	
SF-STL	9/16	3.125	4-5/8	1-1/2	1-1/4	1/8	2-1/16	3-7/8	3-3/8 × 2	1/2	2-5/16	2-13/16	3.0
E-STL	3/4	3.834	6	1-7/8	1-5/8	1/8	2-5/8	5	3-1/2 × 2-3/4	7/8	2-7/8	3-1/2	10.0
F-STL	13/16	4.437	6-5/8	2-13/16	2-1/2	3/16	3-5/8	5-5/8	3-9/16 × 3-5/8	1	35/16	4	11.5
J-STL	1	5.148	7-1/4	3-1/2	3-3/16	3/16	4-1/2	6-1/4	3-5/8 × 4-1/2	17/16	3-3/4	4-1/2	18.0
M-STL	1-1/4	6.500	9	5-1/2	5-3/16	3/16	6-3/4	7-7/8	4-3/4 × 6-3/4	2	4-3/4	5-1/2	37.0
N-STL	1-1/2	7.000	10	6-5/8	6-1/4	7/18	8-1/8	8-1/2	4-7/8 × 8-1/2	2 1/2	5-1/8	5-7/8	57.0

Bushing	Bores	Keyway	Shallow Key Dimension — Standard				Shallow Key Dimension — Standard					
			Keyset	Key	Keyset	Key	Bores	Keyset	Key			
SF-STL	2-3/8 – 2-9/16	5/8 × 3/16										
	2-5/8 – 2-3/4	5/8 × 1/16	1/4 × 1/32	1/4 × 5/32	3/4 × 1/8	3/4 × 1/2	7/8	3/16 × 3/32	3/16 × 3/16			
	2-13/16 – 2-7/8	3/4 × 1/16	1/4 × 1/16	1/4 × 3/16	7/8 × 1/16	7/8 × 1/2	15/16 – 1-1/4	1/4 × 1/8	1/4 × 1/4			
	2-15/16	3/4 × 1/32	3/8 × 1/32	3/8 × 7/32	7/8 × 3/16	7/8 × 5/8	1-5/16 – 1-3/8	5/16 × 5/32	5/16 × 5/16			
	7/8 – 2-7/8	STD.	3/8 × 1/16	3/8 × 1/4	1 × 1/8	1 × 5/8	1-7/16 – 1-3/4	3/8 × 3/16	3/8 × 3/8			
E-STL	2-15/16 – 3-1/4	3/4 × 1/8	3/8 × 1/8	3/8 × 5/16	1-1/4 × 1/4	1-1/4 × 7/8	1-13/16 – 2-1/4	1/2 × 1/4	1/2 × 1/2			
	3-5/16 – 3-1/2	7/8 × 1/16	1/2 × 1/32	1/2 × 9/32	1-1/2 × 1/8	1-1/2 × 7/8	2-5/16 – 2-3/4	5/8 × 5/16	5/8 × 5/8			
F-STL	1 – 3-5/16	STD.	1/2 × 1/16	1/2 × 5/16	1-1/2 × 1/4	1-1/2 × 1	2-13/16 – 3-1/4	3/4 × 3/8	3/4 × 3/4			
	3-3/8 – 3-3/4	7/8 × 3/16	1/2 × 1/8	1/2 × 3/8	1-3/4 × 1/8	1-3/4 × 3/4	3-5/16 – 3-3/4	7/8 × 7/16	7/8 × 7/8			
	3-7/8 – 3-15/16	1 × 1/8	5/8 × 1/16	5/8 × 3/8	1-3/4 × 1/4	1-3/4 × 7/8	3-13/16 – 4-1/2	1 × 1/2	1 × 1			
	4	NONE	3/4 × 1/16	3/4 × 7/16	2 × 1/4	2 × 1	4-9/16 – 5-1/2	1-1/4 × 5/8	1-1/4 × 1-1/4			
J-STL	3-7/16 – 3-3/4	STD.					5-9/16 – 6-1/2	1-1/2 × 3/4	1-1/2 × 1-1/2			
	3-13/16 – 4-1/2	1 × 1/8					6-9/16 – 7-1/2	1-3/4 × 3/4	1-3/4 × 1-1/2			
	2 – 4-3/4	STD.					7-9/16 – 9	2 × 3/4	2-1/2 × 1-1/2			
M-STL	4-13/16 – 5-1/2	11/4 × 1/4	1/4 × 1/32	1/4 × 5/32	3/4 × 1/16	3/4 × 7/16	9-1/16 – 11	2-1/2 × 7/8	—			
	2-1/2 – 5-1/8	STD.	1/4 × 1/16	1/4 × 3/16	3/4 × 1/8	3/4 × 1/2	1-11/16 – 13	3 × 1	—			
N-STL	5-3/16 – 5-1/2	11/4 × 1/4	3/8 × 1/32	3/8 × 7/32	7/8 × 1/16	7/8 × 1/2						
	5-9/16 – 5-7/8	11/2 × 1/4	3/8 × 1/16	3/8 × 1/4	7/8 × 3/16	7/8 × 5/8						
			3/8 × 1/8	3/8 × 5/16	1 × 1/8	1 × 5/8						
			1/2 × 1/32	1/2 × 3/32	1-1/4 × 1/4	1-1/4 × 7/8						
		1/2 × 1/16	1/2 × 5/16	1-1/2 × 1/4	1-1/2 × 1							
		1/2 × 1/8	1/2 × 3/8	1-3/4 × 1/8	1-3/4 × 3/4							
		5/8 × 1/16	5/8 × 3/8	1-3/4 × 3/8	1-3/4 × 1							
		5/8 × 3/16	5/8 × 1/2	2 × 1/4	2 × 1							

Bushing	Plain Bores Not Split
SH-STL	1/2
SD-STL	1/2
SK-STL	1/2
SF-STL	1-15/16
E-STL	7/8 – 1-15/16
F-STL	1 – 2-7/16 – 2-15/16
J-STL	17/16 – 2-15/16
M-STL	2 – 2-15/16
N-STL	2-7/16 – 4-15/16

Reborable QD bushings made of Stainless Steel are available in many sizes. Non stock sizes are available on MTO basis.

Interchangeable Bushings | QD

Standard QD Bushings

Bushing	Dimensions (Inches)								Cap Screws Required	Stock Bore Range			Set Screw Size	Average Weight (lbs) (Approx.)
	A	B	D	E	F	G	L	Bolt Circle		Minimum	Maximum			
											Standard Keyway	Shallow Keyway		
JA	0.375	1.375	2.000	0.688	0.563	0.125	1.000	1.665	3 - 10 x 1	0.375	1.000	1.250	10 - 24	0.90
SH	0.438	1.871	2.688	0.875	0.813	0.125	1.250	2.250	3 - 1/4 x 1-3/8	0.500	1.375	1.688	1/4 - 20	1.00
SDS	0.500	2.187	3.188	0.875	0.750	0.125	1.375	2.688	3 - 1/4 x 1-3/8	0.500	1.688	2.000	1/4 - 20	1.00
SD	0.500	2.187	3.188	0.938	1.250	0.125	1.813	2.688	3 - 1/4 x 1-7/8	0.500	1.688	1.938	1/4 - 20	1.50
SK	0.563	2.812	3.875	1.375	1.250	0.125	1.125	3.313	3 - 5/16 x 2	0.500	2.125	2.500	5/16 - 18	2.00
SF	0.563	3.125	4.625	1.500	1.250	0.125	2.000	3.875	3 - 3/8 x 2	0.500	2.313	2.316	5/16 - 18	3.00
E	0.750	3.834	6.000	1.875	1.625	0.125	2.625	5.000	3 - 1/2 x 2-3/4	0.875	2.875	3.500	3/8 - 16	10.00
F	0.813	4.437	6.250	2.813	2.500	0.188	3.625	5.625	3 - 9/16 x 3-5/8	1.000	3.313	3.938	1/2 - 13	11.50
J	1.000	5.148	7.250	3.500	3.188	0.188	4.500	6.250	3 - 5/8 x 4-1/2	1.438	3.750	4.500	5/8 - 11	18.00
M	1.250	6.500	9.000	5.500	5.188	0.188	6.750	7.875	4 - 3/4 x 6-3/4	1.938	4.750	5.500	3/4 - 10	37.00
N	1.500	7.000	10.250	6.625	6.250	0.250	8.125	8.500	4 - 7/8 x 8-1/2	2.438	5.125	6.000	3/4 - 10	57.00
P	1.750	8.250	11.750	7.625	7.250	0.250	9.375	10.000	4 - 1 x 9-1/2	2.938	5.938	7.000	7/8 - 9	120.00
W	2.000	10.437	15.000	9.375	9.000	0.250	11.375	12.750	4 - 1-1/8 x 1-11/2	4.000	7.500	8.500	1 - 8	250.00
S	3.250	12.125	17.750	12.500	-	0.375	15.750	15.000	5 - 1-1/4 x 15-1/2	6.000	8.250	10.000	1-1/4 - 7	400.00

Inch Bore

Bushing	Bores	Keyway
JA	3/8 - 7/16	NO K.W.
	1/2 - 1	STD.
	1-1/18 - 1-1/8	1/4 - 1/16
	13/16	1/4 - 1/16
SH	1-1/4	NO K.W.
	1/2 - 1-3/8	STD.
	1-7/16 - 1-1/2	3/8 x 1/16
	1-9/16 - 1-5/8	3/8 - 1/16
SDS	1-11/16	NO K.W.
	1/2 - 1-11/16	STD.
	1-3/4	3/8 x 1/8
	1-13/16	1/2 x 1/8
SD	1-7/8 - 1-15/16	1/2 x 1/16
	2	NO K.W.
	1/2 - 1-11/16	STD.
	1-3/4	3/8 x 1/8
SD	1-13/16	1/2 x 1/8
	1-7/8	1/2 x 1/16
	1-15/16	1/2 x 1/16
	2	NO K.W.
SK	1/2 - 2-1/8	STD.
	2-3/16 - 2-1/4	1/2 x 1/8
	2-5/16 - 2-1/2	5/8 x 1/16
	2-9/16 - 2-5/8	NO K.W.
SF	1/2 - 2-1/4	STD.
	2-5/16 - 2-1/2	5/8 x 3/16
	2-9/16 - 2-3/4	5/8 x 1/16
	2-13/16 - 2-7/8	3/4 x 1/16
E	2-15/16	3/4 x 1/32
	7/8 - 2-7/8	STD.
	2-15/16 - 3-1/4	3/4 x 1/8
	3-3/8 - 3-1/2	7/8 x 1/16
F	3-5/16	7/8 x 1/8
	1 - 3-5/16	STD.
	3-3/8 - 3-3/4	7/8 x 3/16
	37/8 - 315/16	1 x 1/8
J	4	NONE
	1-1/4 - 3-3/4	STD.
M	3-13/16 - 4-1/2	1 x 1/8
	2 - 4-3/4	STD.
N	4-13/16 - 5-1/2	1-1/4 x 1/4
	2-7/16 - 5	STD.
	5-1/8 - 5-1/2	1-1/4 x 1/4
P	5-9/16 - 6	1-1/2 x 1/4
	2-15/16 - 5-15/16	STD.
	6 - 6-1/2	1-1/2 x 1/4
W	6-9/16 - 7	1-3/4 x 1/8
	4 - 7-1/2	STD.
	7-9/16 - 8-1/2	2 x 1/4

Millimeter Bore

Bushing	Bores MM	Key Stock Size ★ w x t	
SH	24, 25	8 x 7	
	28, 30		
	32, 35		
SDS	24, 25	8 x 7	
	28, 30		
	32, 35		
SD	38	10 x 8	
	40, 42		
	24, 25		8 x 7
	28, 30		
SK	32, 35	10 x 8	
	38		
	40, 42		12 x 8
	24, 25		
SF	28, 30	8 x 7	
	32, 35		
	38		
	40, 42		
	48, 50		
E	55	16 x 10	
	60		
	28, 30		8 x 7
	32, 35		
	F		38
40, 42			
48, 50			
55			
60			
J	35, 38	10 x 8	
	40, 42		
	48, 50		
	55		
	60, 65		
J	70, 75	20 x 12	
	80, 85		
	90		
	50		14 x 9
	55		
J	60, 65	16 x 10	
	70, 75		
	80, 85		
	90, 95		
	100		

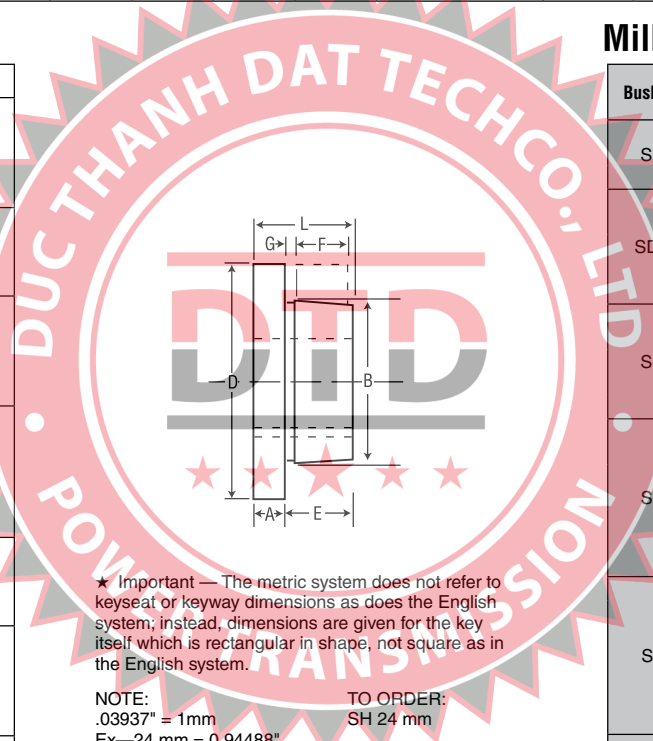

★ Important — The metric system does not refer to keyseat or keyway dimensions as does the English system; instead, dimensions are given for the key itself which is rectangular in shape, not square as in the English system.

NOTE: .03937" = 1mm
Ex—24 mm = 0.94488"

TO ORDER:
SH 24 mm

Keystock provided for nonstandard keyways.

QD Short Bushings

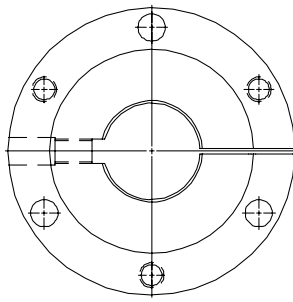

Bushings:
JS

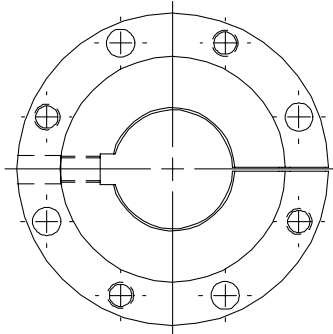

Bushings:
MS to WS inclusive

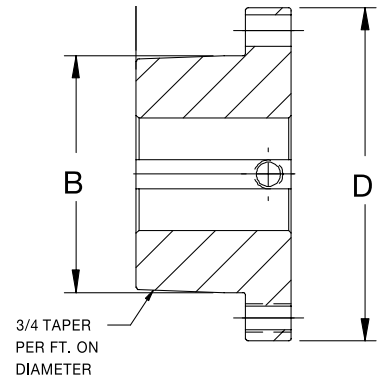

Inch Bore

Bushing	Bores	Keyway	Weight lbs (approx)
JS	2-7/16	5/8 x 5/16	19
	2-15/16	3/4 x 3/8	17
	3-7/16	7/8 x 7/16	15
	3-1/2	7/8 x 7/16	15
MS	3-15/16	1 x 1/8	13
	4-7/16		10
	3-7/16	7/8 x 7/16	38
	3-1/2		37
	3-15/16	1 x 1/2	34
	4-7/16		30
NS	4-15/16	1-1/4 x 1/4	26
	5-7/16		21
	5-1/2	1 x 1/2	20
	3-15/16		54
	4-7/16		49
PS	4-15/16	1-1/4 x 5/8	76
	5-7/16		70
	5-15/16	1-1/2 x 3/4	62
	6		62
	6-7/16	1-1/2 x 1/4	55
	6-1/2		54
WS	6-15/16	1-3/4 x 1/8	47
	7		45
	5-7/16	1-1/4 x 5/8	154
	5-15/16		145
	6		144
	6-7/16		136
	6-1/2	1-1/2 x 3/4	135
	6-15/16		126
	7	1-3/4 x 3/4	125
	7-1/2		114
7-15/16	2 x 1/4		106
8			105
8-7/16	2 x 1/4	94	
8-1/2		93	

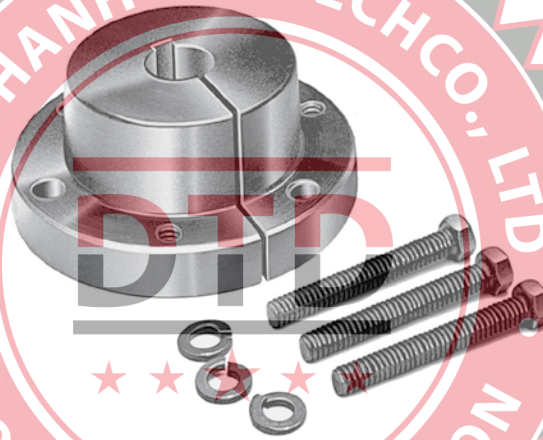

Martin QD Short Bushings are suitable for use in belt conveyor applications wherever the short hubs of a conveyor pulley require the QD Short Bushing style.

Millimeter Bore

Bushing	Dimensions (Inches)						Cap Screws Required	Set Screw Size
	A	B	D	E	L	Bolt Circle		
JS	1.00	5.1484	7.25	2.38	3.38	6.25	5/8 x 2-1/2 (3)	5/8
MS	1.19	6.5000	9.00	3.62	4.81	7.88	3/4 x 3 (4)	3/4
NS	1.50	7.0000	10.00	4.50	6.00	8.50	7/8 x 3-1/2 (4)	3/4
PS	1.50	8.2500	11.75	5.00	6.50	10.00	1 x 4 (4)	7/8
WS	1.75	10.4370	15.00	5.50	7.25	12.75	1-1/8 x 5 (4)	1

IMPORTANT NOTE: Please follow the instructions on this sheet in order for the Martin bushing to perform satisfactorily.

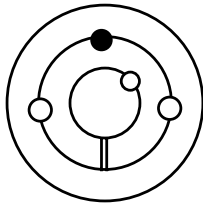

1008 to 3030

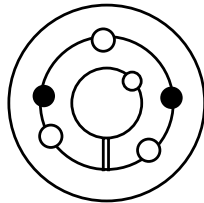

3535 to 6050

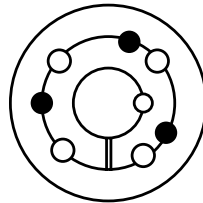

7060 to 10085

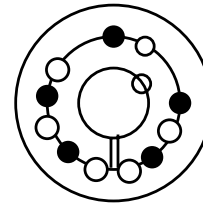

102100

INSTALLATION

1. Clean all oil, dirt, and paint from shaft, bushing bore, outside of bushing and component (sprocket, sheave...etc.) bore.
2. Insert bushing into component. Match the hole pattern, not the threaded holes (each hole will be threaded on one side only.)
3. Thread set or cap screws into those half threaded holes indicated by ○ on above diagram. Mount assembly on shaft.
4. Alternately torque set or cap screws* to recommended torque setting in chart below.
5. On 3535 and larger bushings use a block, sleeve or drift and hammer large end of bushing (do not hammer bushing directly).
6. Repeat steps 4 and 5 until torque wrench reading, after hammering, is the same as before hammering.
7. Fill all unoccupied holes with grease.

REMOVAL

1. Remove all set or cap screws.
2. Insert set or cap screws in holes indicated by ● on drawing. Loosen bushing by alternately tightening set or cap screws.
3. To reinstall, complete all seven (7) installation instructions.

RECOMMENDED TORQUE TABLE

Bushing No.	Set or Cap Screw	Wrench Torque in. / lbs.
1008, 1108	1/4 - 20 Socket Set Screw	55
1210, 1215, 1310	3/8 - 16 Socket Set Screw	175
1610, 1615	3/8 - 16 Socket Set Screw	175
2012	7/16 - 14 Socket Set Screw	280
2517, 2525	1/2 - 13 Socket Set Screw	430
3020, 3030	5/8 - 11 Socket Set Screw	800
3535	1/2 - 13 Socket Head Cap Screw	1,000
4040	5/8 - 11 Socket Head Cap Screw	1,700
4545	3/4 - 10 Socket Head Cap Screw	2,450
5050	7/8 - 9 Socket Head Cap Screw	3,100
6050, 7060, 8065	1-1/4 - 7 Socket Head Cap Screw	7,820
10085, 120100	1 - 1/2 - 6 Socket Head Cap Screw	13,700

* If two bushings are used on same component and shaft, fully tighten one bushing before working on the other.

CAUTION

WARNING: USE OF ANTI-SEIZE LUBRICANT ON TAPERED CONE SURFACES OR ON BOLT THREADS WHEN MOUNTING MAY RESULT IN DAMAGE TO SHEAVES AND SPROCKETS. THIS VOIDS ALL MANUFACTURER'S WARRANTIES.

WARNING: Because of the possible danger to person(s) or property from accidents which may result from the improper use of products, it is important that correct procedures be followed: Products must be used in accordance with the engineering information specified in the catalog. Proper installation, maintenance and operation procedures must be observed. The instructions given above must be followed. Inspections should be made as necessary to assure safe operation under prevailing conditions. All rotating power transmission products when used in a drive are potentially dangerous and must be guarded by the user as required by applicable laws, regulations, standards, and good safety practice. (Refer to ANSI Standard B15.1.)

No. 1008 to 3030 Taper Bushings

Bushing Number	Bore	Wt. lbs (appr)	Bushing Keyseat	Shaft Keyseat
1008	1/2 to 9/16	.27	1/8 x 1/16	1/8 x 1/16
	5/8 to 7/8	.21	3/16 x 3/32	3/16 x 3/32
	15/16 to 1	.16	1/4 x 1/16 ▼	1/4 x 1/8
1108	1/2 to 9/16	.33	1/8 x 1/16	1/8 x 1/16
	5/8 to 7/8	.27	3/16 x 3/32	3/16 x 3/32
	15/16 to 1	.22	1/4 x 1/8	1/4 x 1/8
	1-1/16 to 1-1/8	.17	1/4 x 1/16 ▼	1/4 x 1/8
1210	1/2 to 9/16	.61	1/8 x 1/16	1/8 x 1/16
	5/8 to 7/8	.55	3/16 x 3/32	3/16 x 3/32
	15/16 to 1-1/4	.49	1/4 x 1/8	1/4 x 1/8
1215	1/2 to 9/16	.8	1/8 x 1/16	1/8 x 1/16
	5/8 to 7/8	.7	3/16 x 3/32	3/16 x 3/32
	15/16 to 1-1/4	.6	1/4 x 1/8	1/4 x 1/8
1310	1/2 to 9/16	.7	1/8 x 1/16	1/8 x 1/16
	5/8 to 7/8	.7	3/16 x 3/32	3/16 x 3/32
	15/16 to 1-1/4	.6	1/4 x 1/8	1/4 x 1/8
	1-5/16 to 1-3/8	.6	5/16 x 5/32	5/16 x 5/32
1610	1/2 to 9/16	.9	1/8 x 1/16	1/8 x 1/16
	5/8 to 7/8	.8	3/16 x 3/32	3/16 x 3/32
	15/16 to 1-1/4	.7	1/4 x 1/8	1/4 x 1/8
	1-5/16 to 1-3/8	.7	5/16 x 5/32	5/16 x 5/32
	1-7/16 to 1-1/2	.6	3/8 x 3/16	3/8 x 3/16
1615	1-9/16 to 1-5/8	.5	3/8 x 1/8 ▼	3/8 x 3/16
	1/2 to 9/16	1.2	1/8 x 1/16	1/8 x 1/16
	5/8 to 7/8	1.1	3/16 x 3/32	3/16 x 3/32
	15/16 to 1-1/4	1.0	1/4 x 1/8	1/4 x 1/8
	1-5/16 to 1-3/8	.8	5/16 x 5/32	5/16 x 5/32
2012	1-7/16 to 1-1/2	.7	3/8 x 3/16	3/8 x 3/16
	1-9/16 to 1-5/8	.6	3/8 x 1/8 ▼	3/8 x 3/16
	1/2 to 9/16	1.7	1/8 x 1/16	1/8 x 1/16
	5/8 to 7/8	1.6	3/16 x 3/32	3/16 x 3/32
	15/16 to 1-1/4	1.5	1/4 x 1/8 ▼	1/4 x 1/8
	1-5/16 to 1-3/8	1.4	5/16 x 5/32	5/16 x 5/32
	1-7/16 to 1-3/4	1.2	3/8 x 3/16	3/8 x 3/16
2517	1-13/16 to 1-7/8	1.0	1/2 x 1/4	1/2 x 1/4
	1-15/16 to 2	1.0	1/2 x 3/16 ▼	1/2 x 1/4
	1/2 to 9/16	3.5	1/8 x 1/16	1/8 x 1/16
	5/8 to 7/8	3.4	3/16 x 3/32	3/16 x 3/32
	15/16 to 1-1/4	3.3	1/4 x 1/8	1/4 x 1/8
	1-5/16 to 1-3/8	3.2	5/16 x 5/32	5/16 x 5/32
	1-7/16 to 1-3/4	3.0	3/8 x 3/16	3/8 x 3/16
2525	1-13/16 to 2-1/4	2.4	1/2 x 1/4	1/2 x 1/4
	2-5/16 to 2-1/2	1.9	5/8 x 3/16 ▼	5/8 x 5/16
	3/4 to 7/8	4.9	3/16 x 3/32	3/16 x 3/32
	15/16 to 1-1/4	4.7	1/4 x 1/8	1/4 x 1/8
	15-1/16 to 1-3/8	4.5	5/16 x 5/32	5/16 x 5/32
	1-7/16 to 1-3/4	4.2	3/8 x 3/16	3/8 x 3/16
3020	1-13/16 to 2-1/4	3.3	1/2 x 1/4	1/2 x 1/4
	2-5/16 to 2-3/4	2.5	5/8 x 3/16 ▼	5/8 x 5/16
	15/16 to 1-1/4	6.5	1/4 x 1/8	1/4 x 1/8
	1-5/16 to 1-3/8	6.3	5/16 x 5/32	5/16 x 5/32
	1-7/16 to 1-3/4	6.0	3/8 x 3/16	3/8 x 3/16
3030	1-13/16 to 2-1/4	5.3	1/2 x 1/4	1/2 x 1/4
	2-5/16 to 2-3/4	4.5	5/8 x 5/16	5/8 x 5/16
	2-13/16 to 3	3.9	3/4 x 1/4 ▼	3/4 x 3/8
	15/16 to 1-1/4	9.2	1/4 x 1/8	1/4 x 1/8
	1-5/16 to 1-3/8	8.9	5/16 x 5/32	5/16 x 5/32
	1-7/16 to 1-3/4	8.6	3/8 x 3/16	3/8 x 3/16
3030	1-13/16 to 2-1/4	7.6	1/2 x 1/4	1/2 x 1/4
	2-5/16 to 2-3/4	6.2	5/8 x 5/16	5/8 x 5/16
	2-13/16 to 3	5.0	3/4 x 1/4 ▼	3/4 x 3/8

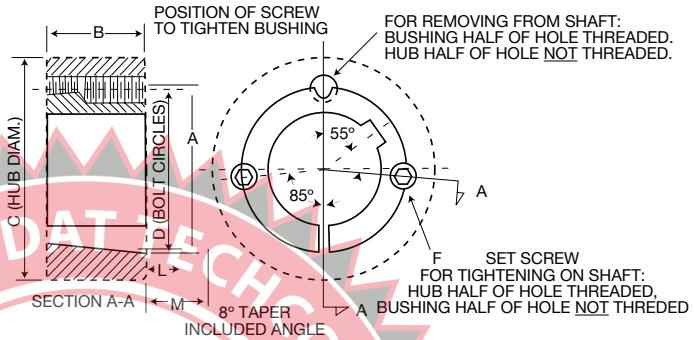

Dimensions

Bushing Number	A	B	C Ø			D	F †	L ★		M ★★	
			Class 20 Gray Iron	Class 30 Gray Iron	Steel			Standard Hex. Key	Short Key ‡	Standard Hex. Key	Short Key ‡
1008	1.386	7/8	2-3/8	2-3/16	1-15/16	1-21/64	1/4 x 1/2	1-1/8	5/8	1-1/4	3/4
1108	1.511	7/8	2-1/2	2-5/16	2-1/16	1-29/64	1/4 x 1/2	1-1/8	5/8	1-1/4	3/4
1210	1-7/8	1	3-5/8	3-1/4	2-7/8	1-3/4	3/8 x 5/8	1-3/8	13/16	1-5/8	1-1/16
1215	1-7/8	1-1/2	3-1/8	2-7/8	2-5/8	1-3/4	3/8 x 5/8	1-3/8	13/16	1-5/8	1-1/16
1310	2	1	3-3/4	3-3/8	3	1-7/8	3/8 x 5/8	1-3/8	13/16	1-5/8	1-1/16
1610	2-1/4	1	4	3-5/8	3-1/4	2-1/8	3/8 x 5/8	1-3/8	13/16	1-5/8	1-1/16
1615	2-1/4	1-1/2	3-1/2	3-1/4	3	2-1/8	3/8 x 5/8	1-3/8	13/16	1-5/8	1-1/16
2012	2-3/4	1-1/4	4-3/4	4-3/8	3-7/8	2-5/8	7/16 x 7/8	1-9/16	15/16	2	1-3/8
2517	3-3/8	1-3/4	5-1/2	4-7/8	4-3/8	3-1/4	1/2 x 1	1-5/8	1	2-1/4	1-5/8
2525	3-3/8	2-1/2	4-3/4	4-1/2	4-1/4	3-1/4	1/2 x 1	1-5/8	1	2-1/4	1-5/8
3020	4-1/4	2	7	6-1/4	5-5/8	4	5/8 x 1-1/4	1-13/16	1-3/16	2-11/16	2-1/16
3030	4-1/4	3	6-1/4	5-3/4	5-3/8	4	5/8 x 1-1/4	1-13/16	1-3/16	2-11/16	2-1/16

Bushings cannot be bored larger than largest bore listed.

For detail dimensions required for machining hubs, consult factory.

- ▼ Key furnished for these sizes only.
- Ø For general reference. Severe conditions may require larger hub. Heavy well-located web may permit smaller hub. Hub diameter required depends on the particular application. Consult *Martin* giving full information on the proposed design. Hub diameters shown are based on 20,000, 30,000, and 50,000 P.S.I. minimum ultimate tensile strength respectively for Class 20 gray iron, Class 30 gray iron, and steel hubs.
- † 2 screws required. Use in positions shown for tightening bushing on shaft. In removing bushing from shaft, remove screws and use one of them in the other hole. Bushing price includes screws.
- ★ Space required to tighten bushing. Also space required to loosen screws to permit removal of hub by puller.
- ★★ Space required to loosen bushing using one screw as jackscrew — no puller required.
- ‡ Standard hex key cut to minimum usable length.

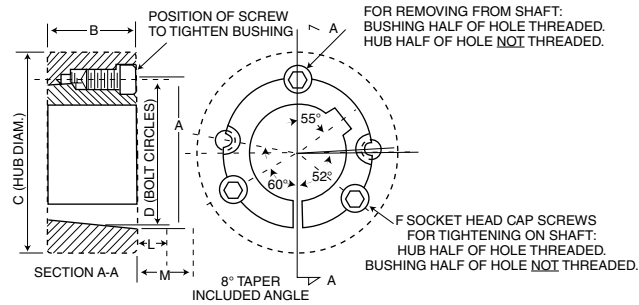
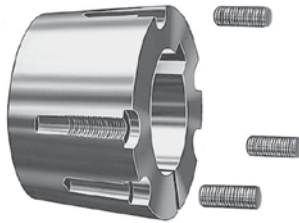

No. 3535 to 5050 Bushings

Bushing Number	Bore	Weight	Bushing Keyseat	Shaft Keyseat	A	B	C Ø			D	F †	G	R
							Class 20 Gray Iron	Class 30 Gray Iron	Steel				
3535	1-3/16 to 1-1/4	14	1/4 × 1/8	1/4 × 1/8	5	3-1/2	7-3/4	7	6-1/2	4.83	1/2 × 1-1/2	39°	▲
	1-5/16 to 1-3/8	14	5/16 × 5/32	5/16 × 5/32									
	1-7/16 to 1-3/4	13	3/8 × 3/16	3/8 × 3/16									
	1-13/16 to 2-1/4	12	1/2 × 1/4	1/2 × 1/4									
	2-5/16 to 2-3/4	11	5/8 × 5/16	5/8 × 5/16									
	2-13/16 to 3-1/4	9	3/4 × 3/8	3/4 × 3/8									
4040	3-5/16 to 3-1/2	8	▼ 7/8 × 1/4	7/8 × 7/16	5-3/4	4	9-1/2	8-1/2	7-3/4	5.54	5/8 × 1-3/4	40°	▲
	1-7/16 to 1-3/4	22	3/8 × 3/16	3/8 × 3/16									
	1-13/16 to 2-1/4	21	1/2 × 1/4	1/2 × 1/4									
	2-5/16 to 2-3/4	19	5/8 × 5/16	5/8 × 5/16									
	2-13/16 to 3-1/4	17	3/4 × 3/8	3/4 × 3/8									
	3-5/16 to 3-5/8	15	7/8 × 7/16	7/8 × 7/16									
4545	3-11/16 to 3-3/4	14	▼ 1 × 1/4	7/8 × 7/16	6-3/8	4-1/2	10-1/2	9-1/2	8-3/4	6.13	3/4 × 2	40°	▲
	3-13/16 to 4	13	▼ 1 × 1/4	1 × 1/2									
	1-15/16 to 2-1/4	30	1/2 × 1/4	1/2 × 1/4									
	2-5/16 to 2-3/4	28	5/8 × 5/16	5/8 × 5/16									
	2-13/16 to 3-1/4	26	3/4 × 3/8	3/4 × 3/8									
	3-5/16 to 3-3/4	23	7/8 × 7/16	7/8 × 7/16									
5050	3-13/16 to 4-1/2	20	1 × 1/2	1 × 1/2	7	5	11-1/2	10-1/2	9-1/2	6.72	7/8 × 2-1/4	37°	▲
	4-9/16 to 5	24	▼ 1-1/4 × 7/16	1-1/4 × 5/8									
	2-5/16 to 2-3/4	38	5/8 × 5/16	5/8 × 5/16									
	2-13/16 to 3-1/4	35	3/4 × 3/8	3/4 × 3/8									
	3-5/16 to 3-3/4	32	7/8 × 7/16	7/8 × 7/16									
	3-13/16 to 4-1/2	27	1 × 1/2	1 × 1/2									

No. 4030 to 5040 Short Taper Bushings

Bushing Number	Bore	Weight	Bushing Keyseat	Shaft Keyseat	A	B	C Ø			D	F †	G	R
							Class 20 Gray Iron	Class 30 Gray Iron	Steel				
4030	1-7/16 to 1-3/4	24	3/8 × 3/16	3/8 × 3/16	5-3/4	3	9-1/2	8-1/2	7-3/4	5.54	5/8 × 1-3/4	39°	▲
	1-13/16 to 2-1/4	21	1/2 × 1/4	1/2 × 1/4									
	2-5/16 to 2-3/4	20	5/8 × 5/16	5/8 × 5/16									
	2-13/16 to 3-1/4	18	3/4 × 3/8	3/4 × 3/8									
	3-5/16 to 3-11/16	15	7/8 × 7/16	7/8 × 7/16									
	3-3/4	13	▼ 7/8 × 3/16	7/8 × 7/16									
4535	3-13/16	13	1 × 1/2	1 × 1/2	6-3/8	3-1/2	10-1/2	9 1/2	8-3/4	6.13	3/4 × 2	40°	▲
	3-7/8 to 4-7/16	13	1 × 1/4	1 × 1/2									
	1-15/16 to 2-1/4	31	1/2 × 1/4	1/2 × 1/4									
	2-5/16 to 2-3/4	29	5/8 × 5/16	5/8 × 5/16									
	2-13/16 to 3-1/4	25	3/4 × 3/8	3/4 × 3/8									
	3-5/16 to 3-11/16	23	7/8 × 7/16	7/8 × 7/16									
5040	3-13/16 to 4-1/2	20	1 × 1/2	1 × 1/2	7	4	11-1/2	10-1/2	9-1/2	6.72	7/8 × 2-1/4	37°	▲
	4-3/8 to 4-1/2	17	▼ 1 × 1/4	1 × 1/2									
	4-3/4 to 4-15/16	15	▼ 1-1/4 × 1/4	1-1/4 × 5/8									
	2-7/16 to 2-3/4	40	5/8 × 5/16	5/8 × 5/16									
	2-13/16 to 3-1/4	37	3/4 × 3/8	3/4 × 3/8									
	3-5/16 to 3-3/4	33	7/8 × 7/16	7/8 × 7/16									
3-13/16 to 4-1/2	29	1 × 1/2	1 × 1/2										
4-3/4 to 5	23	▼ 1-1/4 × 1/4	1 1/4 × 5/8										

Bushings cannot be bored larger than largest bore listed.

For detail dimensions required for machining hubs, consult factory.

▼ Key furnished for these sizes only.

○ For general reference. Severe conditions may require larger hub. Heavy well located web may permit smaller hub. Hub diameter required depends on the particular application. Consult factory giving full information on the proposed design. Hub diameters shown are based on 20,000, 30,000, and 50,000 P.S.I. minimum ultimate tensile strength respectively for Class 20 gray iron, Class 30 gray iron, and steel hubs.

† 3 screws required. Use in positions shown for tightening bushing on shaft. In removing bushing from shaft, remove screws and use two of them in the other two holes. Bushing price includes screws. See following footnote.

▲ Provide sufficient space to tighten and loosen bushing. Width across flats of screw head is same as screw diameter which is shown in column F.

Stock Taper Bushings With Metric Bores and Keyways

★ Metric Bores	★ Metric Keyway	Taper Bushing Number			
14, 16	5 × 2.3	1008 1215	1108 1610	1210 1615	
18, 19 20, 22	6 × 2.8	1008 1610	1108 1615	1210 2012	1215 2517
24	8 × 3.3	1108 1610	1210 1615	1215 2012	2517
25	8 × 3.3	1210 1615	1215 2012	1610 2517	
28, 30	8 × 3.3	1210 1615	1215 2012	1610 2517	3020
32	10 × 3.3	1610 2012	1615 2517	3020	
35	10 × 3.3	1610 2012	1615 2517	3020	
38	10 × 3.3	1610 2012	1615 2517	3020	
40, 42	12 × 3.3	2012 2517	3020		
45, 48	14 × 3.8	2012 2517	3020		
50 55	14 × 3.8 16 × 4.3	2517 2517	3020 3020		

★ Millimeter Bores and Keyways from ISO Std. R773. 1" = 25.4 millimeters

NOTE: For other metric bore sizes consult factory.

Stock Reborable Taper Bushings With No Keyways

Sintered Steel		Gray Iron	Steel	Stainless Steel		
1008	9/16		1008	1/2	1008	1/2
1108	1/2		1108	1/2	1108	
1210	9/16		1210	1/2	1210	1/2
1215	1/2		1215	1/2	1215	
1310	1/2		1310		1310	
1610	1/2 1-5/16		1610	1/2	1610	1/2
1615	1/2 1-5/16		1615	1/2	1615	
2012	1/2		2012	1/2	2012	1/2
2517	1/2 1-9/16		2517	1/2	2517	1/2
		2525	2525		2525	
3020	15/16 1-11/16	2-1/8	3020	15/16	3020	15/16
		15/16 1-7/16 2-15/16	3030		3030	
		15/16 2-7/16 2-15/16	3535		3535	
		1-3/16 2-7/16 2-15/16	4040		4040	
		1-7/16 3-7/16 3-15/16	4545		4545	
		3-15/16 4-7/16				
		2-7/16 3-15/16				
		3-7/16 5-7/16				
		7060				
		3-15/16				
		8065				
		4-7/16				
		10085				
		7				
		H120100				
		8				

★ Not currently stocked. Consult factory for availability and pricing.

Every effort is made to keep all catalog dimensions and styles current in the catalog. However, from time to time it is necessary because of manufacturing changes to alter stock products dimensionally. If any stock product dimension or style in this catalog section is critical to your application please contact *Martin* for certification.

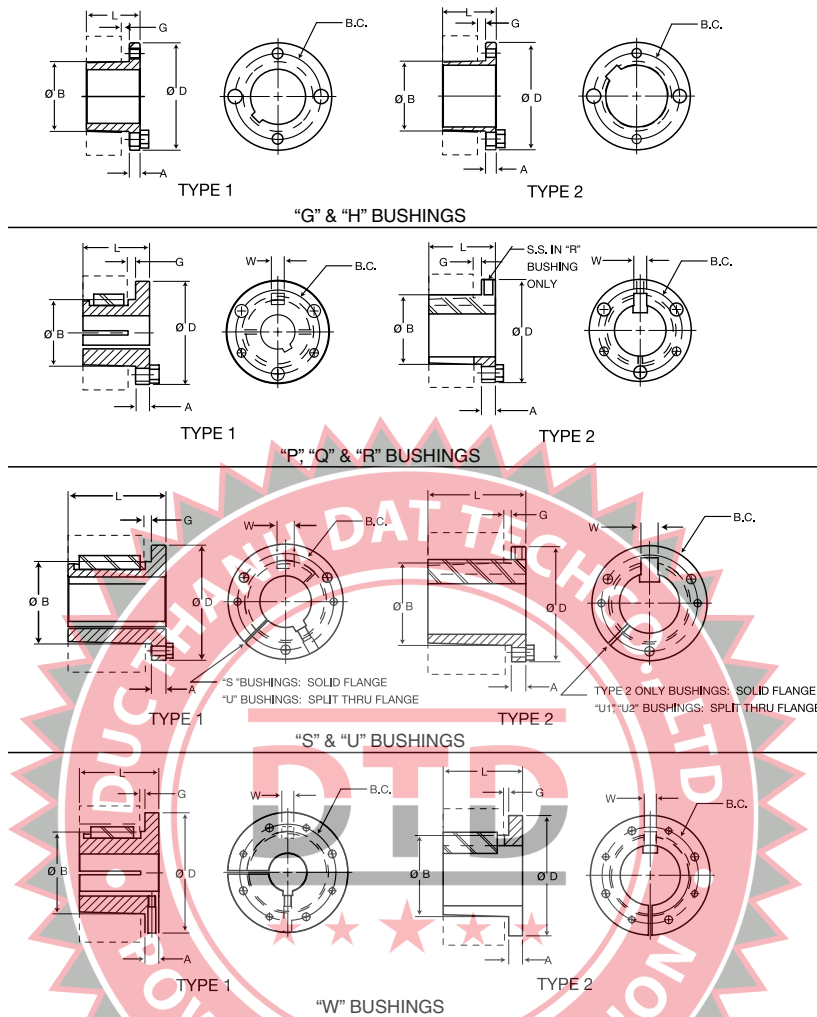

Bushing Specifications

Part Number	Dimensions							Stock Bore Range		Cap Screws		Av. Wt. Lbs.	Wrench Torque in./lbs.
	D	L	A	B Large End	G	B.C.	W	Type 1	Type 2	No.	Size		
G	2.00	1.00	0.25	1.1720	0.19	1.56	—	3/8 – 15/16	1	2	1/4 x 5/8	0.5	95
H	2.50	1.25	0.25	1.6250	0.19	2.00	—	3/8 – 1-3/8	1-7/16 – 1-1/2	2	1/4 x 3/4	0.8	95
P1	3.00	1.94	0.41	1.9375	0.22	2.44	0.375	1/2 – 1-7/16	1-1/2 – 1-3/4	3	5/16 x 1	1.3	192
P2	3.00	2.94	0.41	1.9375	0.22	2.44	0.375	3/4 – 1-7/16	1-1/2 – 1-3/4	3	5/16 x 1	1.5	192
P3	3.00	4.44	0.41	1.9375	0.22	2.44	0.375	1-1/8 – 1-3/8	1-5/8	3	5/16 x 1	2.0	192
Q1	4.12	2.50	0.53	2.8750	0.22	3.38	0.500	3/4 – 2-1/16	2-1/8 – 2-11/16	3	3/8 x 1-1/4	3.5	348
Q2	4.12	3.50	0.53	2.8750	0.22	3.38	0.500	1 – 2-1/16	2-1/8 – 2-5/8	3	3/8 x 1-1/4	4.5	348
Q3	4.12	5.00	0.53	2.8750	0.22	3.38	0.500	1-3/8 – 2-1/16	2-1/8 – 2-1/2	3	3/8 x 1-1/4	5.5	348
R1	5.38	2.88	0.62	4.0000	0.25	4.62	0.750	1-1/8 – 2-13/16	2-7/8 – 3-3/4	3	3/8 x 1-3/4	7.5	348
R2	5.38	4.88	0.62	4.0000	0.25	4.62	0.750	1-3/8 – 2-13/16	2-7/8 – 3-5/8	3	3/8 x 1-3/4	11.0	348
S1	6.38	4.38	0.75	4.6250	0.31	5.38	0.750	1-11/16 – 3-3/16	3-1/4 – 4-1/4	3	1/2 x 2-1/4	13.5	840
S2	6.38	6.75	0.75	4.6250	0.31	5.38	0.750	1-7/8 – 3-3/16	3-1/4 – 4-3/16	3	1/2 x 2-1/4	19.0	840
UO	8.38	5.25	1.06	6.0000	0.44	7.00	1.250	2-3/8 – 3-1/16	—	3	5/8 x 2-3/4	30.0	1680
UO	8.38	4.94	0.75	6.0000	0.44	7.00	1.250	3-1/4 – 4-1/4	4-3/8 – 5-1/2	3	5/8 x 2-3/4	27.0	1680
U1	8.38	7.12	1.06	6.0000	0.44	7.00	1.250	2-3/8 – 4-1/4	4-3/8 – 5-1/2	3	5/8 x 2-3/4	40.0	1680
U2	8.38	10.12	1.06	6.0000	0.44	7.00	1.250	2-7/16 – 4-1/4	4-3/8 – 5	3	5/8 x 2-3/4	50.0	1680
W1	12.50	8.25	1.44	8.5000	0.44	10.00	1.250	3-3/8 – 6-3/16	6-1/4 – 7-7/16	4	3/4 x 3	104.0	3000
W2	12.50	11.25	1.44	8.5000	0.44	10.00	1.250	3-3/8 – 6-3/16	6-1/4 – 7-7/16	4	3/4 x 3	133.0	3000

All tapers are 3/4" per 12" on Diameter.

All dimensions are in inches except, as noted.

All bushings are cast iron, ductile iron, sintered steel, or steel. Consult manufacturer for clarification.

Metric bushings also available.

General Information

Static Conductive Belts

Under certain conditions of temperature and humidity, a belt drive may generate static electricity. Belts intended for operation in a potentially dangerous atmosphere should be constructed with a relatively low electrical resistance characteristic. It has become common practice to specify and refer to such belts as "static conductive," "static dissipating," or "anti-static."

The accumulation of electro-static charges can be dangerous for different reasons:

- Generation of radio interference that can cause disturbance to electrical apparatus
- Risk of ignition and explosion in an atmosphere with high levels of combustible materials
- Risk of injury to workers in contact with the components

V-Belt Drives

Carlisle belts checked on the chart to the right are static conductive based on testing developed by the Association for Rubber Products Manufacturers (ARPM Bulletin IP3-3). These belts are branded as "static dissipating."

Synchronous Belt Drives

Carlisle synchronous belts are not static dissipating.

Carlisle® Belts	Cross Section	Static Dissipating
Panther®XT Synchronous Belt	8M, 14M	No
Panther® Synchronous Belt	8M, 14M, 20M	No
Synchro-Cog® HT Belt	3M, 5M, 8M, 14M	No
Dual Synchronous Belt	D8M, D14M	No
Synchro-Cog® Timing Belt	XL, L, H, XH, XXH	No
Air Cool Heat Exchange Belt	14M	No
Cotton Drive® Timing Belt	CCB	No
Gold-Ribbon® Cog-Belt®	AX, BX, CX, DX	✓
Super II® V-Belt	A, B, C	✓
Super Blue Ribbon® V-Belt	AP, BP, CP, DP, EP	✓
Aramax® Xtra Duty V-Belt	3L, AK, BK	No
Power-Wedge® Cog-Belt®	3VX, 5VX, 8VX	✓
Metric Power-Wedge® Cog-Belt®	SPZX, SPAX, SPBX, SPCX	✓
Super Power-Wedge® V-Belt	5V, 8V	✓
Double Angle V-Belt	AA, BB, CC	Special Order Only
Vee-Rib™ Belt	J	No
Variable Speed Cog-Belt	Various	✓
Gold-Ribbon® Cog-Band®	RBX, RCX, RDX, RBL, RCL, RDL	✓
Power-Wedge® Cog-Band®	R3VX, R5VX	✓
Wedge-Band®	R3V, R5V, R8V	✓
Aramax® Wedge-Band®	R8VK	✓
Wedge-Band® Chipper Drive	R5VL	Special Order Only
Super Vee-Band®	RBP, RCP, RDP	✓
Durapower®II FHP V-Belt	2L, 3L, 4L, 5L	✓
Dry Can Belt	CC	Special Order Only
Thoro-Twist™ V-Belting	3L, A, B, C	No
Round Belts	7/16, 9/16	Special Order Only

General Information

V-Belt Construction & Drive Advantages

V-Belt Construction

There are two major types of v-belt construction, wrapped and raw edge. Wrap Molded belts are molded into a "V" shape and have a fabric cover. Raw Edge Cog-Belts are cured and then cut into a "V" shape.

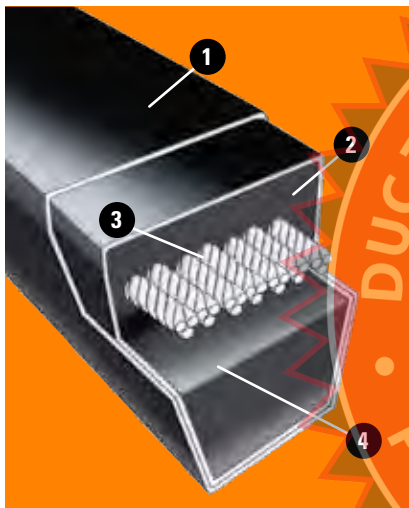

Wrapped Belt

- 1. Cover** – Woven cotton fabric impregnated with engineered rubber compounds
- 2. Tension Section** – Synthetic rubber specially formulated to stretch as belt bends around sheaves
- 3. Cords** – High-strength, synthetic fiber cords carry the horsepower load and minimize stretching
- 4. Compression Section** – Synthetic rubber developed to support cords evenly and compress while bending around sheaves

Raw Edge Cog-Belt

- 1. Cords** – Synthetic high-modulus cords form the strength member to carry high loads with minimum stretching
- 2. Raw Edge Sidewalls** – Provide uniform, anti-slip surface, greater flexibility and allows more cord width
- 3. Compression Section** – Exclusive stiff-flex rubber compounds and precision molded cogs increase flexibility while supporting cords evenly

V-Belt Drive Advantages

V-belt drives provide many advantages that help to reduce equipment repairs and to hold downtime to a minimum.

- **V-belts** are rugged – they will give years of trouble-free performance when given minimal attention, even under adverse conditions
- **V-belts** are clean – they require no lubrication
- **V-belts** are efficient – performing with an average of 93% efficiency; Raw Edge cog-belts are 95% efficient
- **V-belts** are smooth starting and running
- **V-belts** cover extremely wide horsepower ranges
- **V-belts** permit a wide range of driven speeds, using standard electric motors
- **V-belts** dampen vibration between driving and driven machines
- **V-belts** are quiet
- **V-belts** act as a "safety fuse" in the powertrain
- **V-belts** and sheaves wear gradually – making preventive and corrective maintenance simple and easy

General Information

V-Belt Troubleshooting Guide

Some of the more common symptoms of short v-belt life are listed in the chart below. This chart is intended to help identify the cause of short belt life so problems can be addressed and corrected. For more information on proper v-belt maintenance, request the "Service Manual for Industrial V-Belt Drives" from your local distributor of Carlisle belts. It is also available at carlislebelts.com/ServiceManual or by simply scanning the QR code to the right.

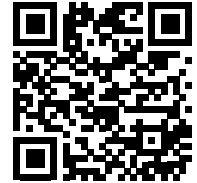

Symptoms	Belts pried on or misplaced slack	Belts rubbing guard	Sheaves misaligned	Worn or damaged sheaves	Sheaves too far from bearing	Poor bearing or shaft condition	Insufficient tension	Excessive tension	Improper sheave installation	Belts worn (normal service life)	Wrong belt cross-section or type	Mismatched belts or mixed brands	Machine-induced impulse or shock	Improper or prolonged storage	Excessive heat	Excessive oil or grease	Use of belt dressing	Abrasive environment	Foreign objects in grooves	Excessive moisture	Overloaded drive/underbelting	Drive seriously overbelted	Sheaves too small	Insufficient wrap on small sheave	Backside idler	Harmonics
Rapid sidewall wear		■	■	■																						
Worn cover on back		■																								
Belt turns over or jumps off sheave	■	■	■																							
Belt soft, swollen																										
Belt slips, squeals (spin burn)	■																									
Belt cover split	■																									
Underside cracked																										
Tie-band damaged			■	■																						
Snub break	■																									
Belts ride too high																										
Belts bottoming																										
Repeated take-up necessary	■																									
Belts vibrate excessively or appear mismatched	■																									
Bearings are hot																										
Shafts whip or bend																										
Cracked bushings																										
Sheave wobble																										

■ Indicates most common causes ■ Indicates other possible causes

General Information

Synchronous Belt Drive Troubleshooting Guide

Type of Failure	Cause of Failure	Corrective Action
Excessive edge wear (exposed tensile member)	Misalignment or non-rigid centers	Check alignment and/or reinforce mounting
	Belt flange	Straighten flange
Jacket wear on pressure-face side of belt tooth	Excessive overload and/or incorrect tension	Change installation tension and/or increase drive load carrying capacity
Excessive jacket wear between belt teeth (exposed tension members)	Excessive installation tension	Reduce installation tension
Cracks in backing	Exposure to excessive low temp (below -30°F)	Eliminate low temperature condition or consult factory for proper belt construction
	Chemical exposure	
Softening of backing	Chemical and/or oil	Eliminate oil condition or consult factory for proper belt construction
Excessive sprocket tooth wear (on pressure-face and/or OD)	Excessive overload and/or excessive belt tightness	Reduce installation tension and/or increase drive load-carrying capacity
	Insufficient hardness of sprocket material	Surface harden sprocket or use harder material
	Normal wear/end-of-service/grit or debris	Replace sprockets
Unmounting of flange	Incorrect flange installation	Reinstall flange correctly
	Misalignment	Correct alignment
Excessive drive noise*	Misalignment	Correct alignment
	Excessive installation tension	Reduce tension
	Excessive load	Increase drive load-carrying capacity
	Sub-minimum sprocket diameter	Increase sprocket diameters
	High speeds	Slow drives down
Tooth shear	Less than 6 teeth in mesh (TIM)	Increase TIM or use next smaller pitch
	Excessive load	Increase drive load-carrying capacity
	Low tension	Increase tension
Apparent belt stretch	Reduction of center distance or non-rigid mounting	Re-tension drive and/or reinforce mounting
Cracks or premature wear at belt tooth root	Improper sprocket groove top radius	Re-groove or install new sprockets
	Low tension	Increase tension
Tensile break	Excessive load	Increase load-carrying capacity of drive
	Sub-minimum sprocket diameter	Increase sprocket diameters

*NOTE: Effective noise reduction for power transmission drives can be accomplished by incorporating a flexible noise absorbing material with the protective guard. The guard design must allow a cooling air passage on the top and bottom to prevent overheating the drive.

General Information

V-Belt Installation Check List & Selection Guide

V-Belt Installation Check List

- 1. Cut off and lock out power source
- 2. Observe all safety procedures
- 3. Follow the recommendations of the original equipment manufacturer
- 4. Remove belt guard
- 5. Loosen motor mounts
- 6. Shorten center distance
- 7. Remove old belts
- 8. Inspect belt wear patterns for possible troubleshooting
- 9. Inspect drive elements – bearings, shaft, etc
- 10. Inspect sheaves for wear; clean sheaves
- 11. Check sheave alignment (preliminary)
- 12. Select proper replacement belts
- 13. Install new belts
- 14. Properly tension belts
- 15. Check sheave alignment (final)
- 16. Replace guard
- 17. Start drive (look and listen)
- 18. Check tension after 24 hours

Carlisle® Belts by Timken	Chek Mate® Matching	Generic Belt Type (Cross Sections)	Normal Horsepower Range
Gold-Ribbon® Cog-Belt**		Classical Cogged Multiple (AX, BX, CX, DX)	1-500
Super II® V-Belt		Classical Multiple (A, B, C)	1-500
Super Blue Ribbon® V-Belt		Classical Multiple (A, B, C, D)	1-500
Aramax® Xtra Duty V-Belt		Classical Multiple (3L, AK, BK)	1-500
Power-Wedge® Cog-Belt**		Narrow Cogged Multiple (3VX, 5VX, 8VX)	1-600
Metric Power-Wedge® Cog-Belt®		Narrow Cogged Multiple (SPZX, SPAX, SPBX, SPCX)	1-600
Super Power-Wedge®		Narrow Multiple (5V, 8V)	1-1000
Double Angle V-Belt		Double V-Belts (AA, BB, CC)	1-200
Vee-Rib™		V-Ribbed (J)	4-500
Gold-Ribbon® Cog-Band®		Classical Cogged Banded (RBX, RCX, RDX)	1-500
Power-Wedge® Cog-Band®		Narrow Cogged Banded (R3VX, R5VX)	1-1000
Wedge-Band®		Narrow Banded (R3V, R5V, R8V)	1-1000
Aramax® Wedge-Band®		Narrow Banded (R8VK)	1-2000
Wedge-Band® Chipper Drive		Narrow Banded (R5VL)	1-600
Super Vee-Band®		Classical Banded (RBP, RCP, RDP)	1-500
Durapower® II		FHP (2L, 3L, 4L, 5L)	Light Duty
Dry-Can Belt		Double Angle (CC***S)	1-500
Thoro-Twist™		Link (3L, A, B, C)	1-300
Round Belts		Round (716R, 916R)	1-200

This symbol indicates product manufactured to **chekmate** tolerances.

General Information

V-Belt Installation Check List & Selection Guide

Maximum Belt Speed (FT/Min) ⁽¹⁾	Normal Temperature Range (°F) ⁽²⁾		Oil/Heat Resistance	Static Dissipating	General Application
	Min.	Max.			
6500	-50	250	Good	✓	Longer life, high efficiency, small diameters
6500	-35	120	Good	✓	General purpose heavy duty industrial drives
6500	-35	120	Good	✓	General purpose heavy duty industrial drives
6500	-35	120	Good	No	General purpose heavy duty industrial drives
6500	-50	250	Good	✓	High-performance, compact industrial drives
6500	-50	250	Good	✓	High-performance, compact industrial drives
6500	-35	130	Very Good	✓	High-performance, compact industrial drives
6500	-35	120	Good	Special Order Only	Serpentine drives
6500	-35	130	Very Good	No	Small diameters, high speed ratios, compact
6500	-35	130	Good	✓	Longer life, high efficiency, reduces belt whip, turnover on pulsating surge loads
6500	-35	130	Good	✓	Eliminates belt whip and turnover
6500	-35	130	Very Good	✓	Eliminates belt whip and turnover
6500	-35	130	Very Good	✓	Heavy duty, high load machinery
6500	-35	130	Very Good	Special Order Only	Chipper drives
6500	-35	120	Good	✓	Eliminates belt whip and turnover
6500	-35	120	Fair	✓	Using a single belt/low load/small HVAC
6500	-35	120	Good	Special Order Only	Dry-Can applications
5000 (1000 min.)	-35	130	Excellent	No	Emergency replacement, fixed center distance
6500	-35	130	Good	Special Order Only	Conveyor applications

Notes: (1) Normally limited by sheave materials. (2) Expect moderate life loss due to heat.

* Some Carlisle belts are now made of EPDM (Ethylene Propylene Diene Monomer), a synthetic rubber with outstanding properties. EPDM is durable, static conductive and resistant to oil, heat, hardening and glazing. The operating temperature range of EPDM is -50° to +250°F.

General Information

Banded V-Belt Matching Limits

Matching numbers are indicated on each banded belt next to the brand, e.g. 49, 50, 51, etc. For example, a match limit of 1 in the table below indicates the belts must all have the same matching number. Similarly, a match limit of 2 indicates that a matched set may consist of any two adjacent matching numbers, i.e. 49 and 50 would constitute a matched set.

Product Type and Length Code	Match Limit
Gold-Ribbon® Cog-Band®	
RBX51 – RBX61	1
RBX62 – RBX144	2
RBX158 and longer	3
RCX68 – RCX144	2
RCX158 and longer	3
RDX120 – RDX144	2
RDX158 and longer	3
Wedge-Band®	
R3VX250 – R3VX630	1
R3VX670 – R3VX1400	2
R5VX500 – R5VX630	1
R5VX670 – R5VX1500	2
R5VX1600 and up	3
R8V1000 – R8V1500	2
R8V1600 and up	3
Super Vee-Band®	
RBP35 – RBP60	1
RBP61 – RBP144	2
RBP148 and up	3
RCP51 – RCP60	1
RCP68 – RCP144	2
RCP158 and up	3
RDP120 – RDP144	2
RDP158 and up	3

Spring-Loaded Belt Tensiometer

Proper tensioning is one of the most important factors necessary for long, satisfactory operation. This tensioning method is based on the fact that the force required to deflect a given span length by a given amount is related to the tension in the belt.

Procedure for Using the Tensiometer

1. Measure the span length of the drive. (See Fig. 2). Set the large "O" ring at $1/64$ " for each inch of belt span. For example, set the large "O" ring at $1/4$ " for a span length of 16," at $1/2$ " for a span length of 32," or at 1" for a span length of 64", etc.
2. Set the small "O" ring at zero (See Fig. 1) and press down the Tensiometer at the center of the belt span.
 - a. On a single belt drive, depress the tensiometer until the large "O" ring is even with the bottom of a straight edge placed on the outside rims of the two sheaves.
 - b. On a multiple belt drive, depress the Tensiometer until the large "O" ring is even with the top of the next belt. Measure each belt in the drive and take the average reading of all belt tensions.
3. Remove the Tensiometer and observe that the small "O" ring has moved from its original setting at zero to the number of pounds required to deflect the belt.
4. Check this reading against the value of the deflection force in the V-Belt Tensioning table (page 341).

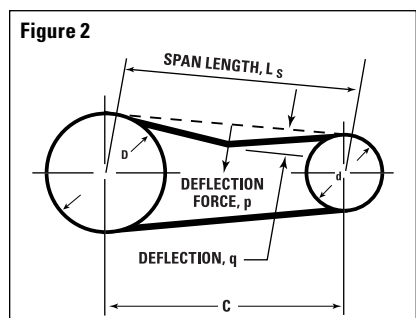
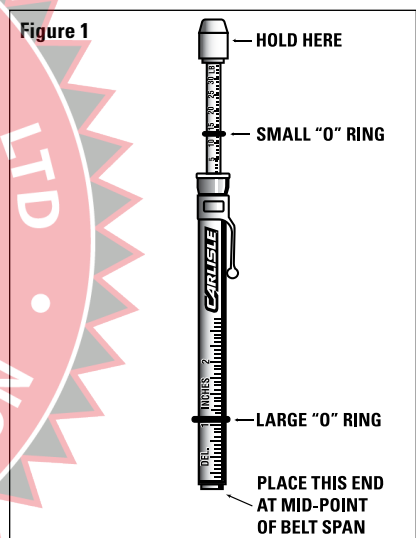

Guidelines presented are suggestions to help install and maintain belts properly. Please always follow the recommendations of the original equipment manufacturer.

General Information

V-Belt Tensioning

Average Tensioning Values (recommended minimum force per belt)

This table shows minimum deflection force values. New belts should be installed at 2.0 times these values.
Used belts should be between 1.0 and 1.5 times these values.

Carlisle Belts	V-Belt Section	Small Sheave		Deflection Force for the Drive Speed Ratio (lbs.)			
		Speed Range	Diameter	1.0	1.5	2.0	4.0 and over
Super II® & Super Blue Ribbon®	A AP	1800-3600	3.0	2.0	2.3	2.4	3.3
		1800-3600	4.0	2.6	2.8	3.0	3.3
		1800-3600	5.0	3.0	3.3	3.4	3.7
		1800-3600	7.0	3.5	3.7	3.8	4.3
	B BP	1200-1800	4.6	3.7	4.3	4.5	5.0
		1200-1800	5.0	4.1	4.6	4.8	5.6
		1200-1800	6.0	4.8	5.3	5.5	6.3
	C CP	1200-1800	8.0	5.7	6.2	6.4	7.2
		900-1800	7.0	6.5	7.0	8.0	9.0
		900-1800	9.0	8.0	9.0	10.0	11.0
	DP	900-1800	12.0	10.0	11.0	12.0	13.0
		700-1500	16.0	12.0	13.0	13.0	14.0
		900-1500	12.0	13.0	15.0	16.0	17.0
		900-1500	15.0	16.0	18.0	19.0	21.0
		700-1200	18.0	19.0	21.0	22.0	24.0
		700-1200	22.0	22.0	23.0	24.0	26.0
Gold-Ribbon® Cog-Belt®	AX	1800-3600	3.0	2.5	2.8	3.0	3.3
		1800-3600	4.0	3.3	3.6	3.8	4.2
		1800-3600	5.0	3.7	4.1	4.3	4.6
		1800-3600	7.0	4.3	4.6	4.8	5.3
	BX	1200-1800	4.6	5.2	5.8	6.0	6.9
		1200-1800	5.0	5.4	6.0	6.3	7.1
		1200-1800	6.0	6.0	6.4	6.7	7.7
	CX	1200-1800	8.0	6.6	7.1	7.5	8.2
		900-1800	7.0	10.0	11.0	12.0	13.0
		900-1800	9.0	11.0	12.0	13.0	14.0
	DX	900-1800	12.0	12.0	13.0	13.0	14.0
		700-1500	16.0	13.0	14.0	14.0	15.0
		900-1500	12.0	16.0	18.0	19.0	20.0
		900-1500	15.0	19.0	21.0	22.0	24.0
	3VX	700-1200	18.0	22.0	24.0	25.0	27.0
		700-1200	22.0	25.0	27.0	28.0	30.0
1200-3600		2.2	2.2	2.5	2.7	3.0	
1200-3600		2.5	2.6	2.9	3.1	3.6	
1200-3600		3.0	3.1	3.5	3.7	4.2	
1200-3600		4.1	3.9	4.3	4.5	5.1	
1200-3600		5.3	4.6	4.9	5.1	5.7	
1200-3600		6.9	5.0	5.4	5.6	6.2	
5VX	1200-3600	4.4	6.5	7.5	8.0	9.0	
	1200-3600	5.2	8.0	9.0	9.5	10.0	
	1200-3600	6.3	9.5	10.0	11.0	12.0	
	1200-3600	7.1	10.0	11.0	12.0	13.0	
	900-1800	9.0	12.0	13.0	14.0	15.0	
	900-1800	14.0	14.0	15.0	16.0	17.0	
8VX	900-1800	12.5	18.0	21.0	23.0	25.0	
	900-1800	14.0	21.0	23.0	24.0	28.0	
	700-1500	17.0	24.0	26.0	28.0	30.0	
	700-1200	21.2	28.0	30.0	32.0	34.0	
	400-1000	24.8	31.0	32.0	34.0	36.0	
Super Power-Wedge®	5V	900-1800	7.1	8.5	9.5	10.0	11.0
		900-1800	9.0	10.0	11.0	12.0	13.0
		900-1800	14.0	12.0	13.0	14.0	15.0
		700-1200	21.2	14.0	15.0	16.0	17.0
	8V	900-1800	12.5	18.0	21.0	23.0	25.0
		900-1800	14.0	21.0	23.0	24.0	28.0
		700-1500	17.0	24.0	26.0	28.0	30.0
		700-1200	21.2	28.0	30.0	32.0	34.0
		400-1000	24.8	31.0	32.0	34.0	36.0

General Information

Brand Name Interchange

Belt Type/Cross Section	Carlisle® Belts by Timken	Bando®	Browning® (Regal®)
Extra High Torque Synchronous 8M, 14M	‡ PantherXT (Part # example:14MXT-994-20)	King Power (KPS II) (STPD sprockets only)	HPT Chain
High Torque Synchronous 8M, 14M, 20M	Panther (* RPP profile) (Part # example: 960-8MPT-20)	High Performance STS (STPD sprockets only)	HPT Plus
HTD Synchronous 3M, 5M, 8M, 14M	Synchro-Cog HT (Part # example: 600-8M-50)	Synchro-Link STS (STPD sprockets only)	HPT
Dual Sided Curvilinear D8M, D14M	Dual Synchronous (Part # example: D950-8M-50)	—	—
Timing Belt (Trapezoidal) XL, L, H, XH, XXH	Synchro-Cog Timing Belt (Part # example: 770XL025)	Synchro-Link Timing Belt	Gearbelt
Dual Sided Timing DXL, DL, DH	—	Synchro-Link Double Sided	Double Gearbelt
Classical Raw Edge Cogged AX, BX, CX, DX	Gold-Ribbon Cog-Belt (Part # example: BX85)	Power King Cog (Part # example: BX85)	Gripnotch (Part # example: BX85)
Raw Edge Classical A,B,C	Super II V-Belt (Part # example: B85)	—	—
Classical (Conventional) Wrapped A, B, C, D, E	† Super Blue Ribbon V-Belt (Part # example: BP85)	Power King (Part # example: B85)	Super Gripbelt (Part # example: B85)
Narrow Cogged 3VX, 5VX, 8VX	Power-Wedge Cog-Belt (Part # example: 5VX850)	Power Ace Cog (Part # example: 5VX850)	358 Gripnotch (Part # example: 5VX850)
Narrow 5V, 8V	Super Power-Wedge (Part # example: 5V850)	Power Ace (Part # example: 5V850)	358 Gripbelt (Part # example: 5V850)
Double-V Hexagonal AA, BB, CC	Double Angle V-Belt (Part # example: BB75)	Double V (Part # example: BB75)	Double-V Gripbelt (Part # example: BB75)
V-Ribbed J	Vee-Rib (Part # example: 490J8)	Rib Ace (Part # example: 490J8)	Poly-V (Part # example: 490J8)
Variable Speed	Variable Speed Cog-Belt (Part # example: 2322V721)	Power Max	V-S Belt
Classical Cogged Banded RBX, RCX, RDX, RBL, RCL, RDL	Gold-Ribbon Cog-Band (Part # example: RBX85-3)	Power King Cog Combo	Gripband (Part # example: 3GBBX85)
Narrow Cogged Banded R3VX, R5VX	Power-Wedge Cog-Band (Part # example: R5VX850-3)	Power Ace Cog Combo	—
Narrow Banded R3V, R5V, R8V	Wedge-Band (Part # example: R5V850-3)	Power Ace Combo	358 Gripband (Part # example: 3GB5V850)
Classical Banded RB, RC, RD	Super Vee-Band (Part # example: RBP85-3)	Power King Combo	Gripband (Part # example: 3GBB85)
Light-Duty FHP 2L, 3L, 4L, 5L	Durapower II (Part # example: 4L400R)	Duraflex GL	FHP (Part # example: 4L400)

† Carlisle uses an AP, BP, CP, DP, EP designation for classical v-belts, industry standard is A, B, C, D, E.

* RPP profile is interchangeable with HTS, PGGT2, HPPD, Hawk and HTD sprockets.

‡ Use Martin MPC® or drop into existing Poly Chain® GT®2 sprockets – not interchangeable with RPP sprockets.

** The part number consists of a prefix and a length designation. Prefixes: 2L = 0, 3L = 1, 4L = 2, 5L = 3

Note: Product names are trademarks of their respective companies.

General Information

Brand Name Interchange

ContiTech®	Gates®	Jason® (Megadyne®)	MBL®
SynchroChain or Falcon PD	Poly Chain GT Carbon	RPP Platinum	GigaTorque
BlackHawk PD	Power Grip GT2	Tiger	
Hawk PD	Power Grip GT HTD	HTB (HTD)	High Torque Timing
Dual Hi-Performance Pd	GT2 Twin Power	Dual HTB (HTD)	
Positive Drive	Power Grip	Standard Timing	Three Stars Timing
Dual Positive Drive	Power Grip Twin Power	Dual Timing	Three Stars Dual Timing
Torque Flex (Part # example: BX85)	Tri-Power Molded Notch (Part # example: BX85)	Uni-Match Cogged (Part # example: BX85)	Raw Edge Cogged (Part # example: BX85)
—	—	—	—
HY-T (Part # example: B85)	Hi-Power II (Part # example: B85)	Uni-Match (Part # example: B85)	Conventional (Part # example: B85)
HY-T Wedge Cog (Part # example: 5VX850)	Super HC Molded Notch (Part # example: 5VX850)	Uni-Match cogged (Part # example: 5VX850)	Maxstar Wedge Supreme (Part # example: 5VX850)
HY-T Wedge (Part # example: 5V850)	Super HC (Part # example: 5V850)	Uni-Match Deep Wedge (Part # example: 5V850)	Maxstar Wedge (Part # example: 5V850)
Hex (Part # example: BB75)	Hi-Power II Double V (Part # example: BB75)	Double Multiple V-Belt (Part # example: BB75)	Double (Part # example: BB75)
Poly-V (Part # example: 490J8)	Micro-V (Part # example: 490J8)	Multi-Rib (Part # example: 490J8)	Ribstar (Part # example: 490J8)
Variable Speed	Multi-Speed	Variable Speed	Vari-Star
Torque Team Cogged (Part # example: 3/BX85)	Tri-Power Molded Notch (Part # example: 3/BX85)	Uni-Match	
—	—	—	—
HY-T Wedge Torque Team (Part # example: 3/5V850)	Super HC Power Band (Part # example: 3/5V850)	Uni-Match Wedge Banded (Part # example: R5V850-3)	
HY-T Torque Team (Part # example: 3/B85)	Hi-Power II Power Band (Part # example: 3/B85)		Conventional Banded
FHP (Part # example: 4L400)	Truflex **(Part # example: 2400)	FHP	FHP

Bando® is a registered trademark of Bando Chemical Industries, Ltd. Optibelt® is a registered trademark of the OPTIBELT Corporation. PIX® is a registered trademark of Pix Transmissions Limited. Thermoid® is a registered trademarks of HBD/Thermoid, Inc. TB Woods® is a registered trademark of Altra Industrial Motion Corp. Browning® is a registered trademark of Regal Beloit America, Inc. ContiTech® is a registered trademark of ContiTech AG. Gates®, PowerGrip®, HTD® and GT® are registered trademarks of Gates Corporation. Jason® is a registered trademark of Jason Industrial, Inc. Megadyne® is a registered trademark of Megadyne S.p.A. MBL® is a registered trademark of Mitsubishi Belting Ltd. Martin® MPC® are registered trademarks of Martin Sprocket & Gear, Inc. Note: Product names are trademarks of their respective companies.

General Information

Brand Name Interchange – Continued

Belt Type/Cross Section	Optibelt®	PIX®	Thermoid®	TB Woods®
Extra High Torque Synchronous 8M, 14M		—	—	QT PowerChain® II GT2 tooth profile
High Torque Synchronous 8M, 14M, 20M	Omega HP	Pix-X'act HP	—	
HTD Synchronous 3M, 5M, 8M, 14M	Omega HL	Pix-X'act HTD	Grip-Tite HT	Synchronous Plus (Part # example: 600-8M-50)
Dual Sided Curvilinear D8M, D14M	—	—	—	Twin Power (Part # example: TP950-8M-50)
Timing Belt (Trapezoidal) XL, L, H, XH, XXH	Timing Belt ZR	Pix-X'act CT	Grip-Tite Timing	Sure Grip Timing (Part # example: 770XL025)
Dual Sided Timing DXL, DL, DH	Double Timing ZRD	—	Grip-Tite Dual Timing	Twin Power Timing (Part # example: TP770XL025)
Classical Raw Edge Cogged AX, BX, CX, DX	Optibelt Super TX M-S (Part # example: BX85)	Pix-X'tra cogged (Part # example: BX85)	Prime Mover Cogged (Part # example: BX85)	Torque Flex II (Part # example: BX85)
Raw Edge Classical A,B,C	—	—	—	—
Classical (Conventional) Wrapped A, B, C, D, E	VB (Part # example: B85)	Pix-X'set Classical (Part # example: B85)	Prime Mover (Part # example: B85)	Sure Grip (Part # example: BP85)
Narrow Cogged 3VX, 5VX, 8VX	Super TX M=S (Part # example: 5VX850)	Pix-X'tra cogged wedge (Part # example: 5VX850)	Maxipower Cogged (Part # example: 5VX850)	Ultra-V Cog (Part # example: 5VX850)
Narrow 5V, 8V	Optibelt SK (Part # example: 5V850)	Pix-X'set Narrow (Part # example: 5V850)	Maxipower (Part # example: 5V850)	Ultra-V (Part # example: 5V850)
Double-V Hexagonal AA, BB, CC	Optibelt DK (Part # example: BB75)	Pix-X'set DS Hexagonal (Part # example: BB75)	Hex Double V (Part # example: BB75)	Double-V (Hex) (Part # example: BB75)
V-Ribbed J	Ribbed Belt RB (Part # example: 490J8)	PIX-X'ceed (Part # example: 490J8)	Multi-Ribbed (Part # example: 490J8)	Poly-V (Part # example: 490J8)
Variable Speed	Super VX	Pix-X'tra VS	Variable Speed	Variable Speed (Part # example: 2322V721)
Classical Cogged Banded RBX, RCX, RDX, RBL, RCL, RDL	Kraftbands KBX			Cog Flex Banded (Part # example: 3RBX85)
Narrow Cogged Banded R3VX, R5VX	—	Pix-X'tra MB Cogged Banded	—	Ultra-V Cog Banded (Part # example: 3R5VX850)
Narrow Banded R3V, R5V, R8V	Kraftbands KB	Pix-X'Set MB Wedge Banded	Maxi-Power Band (Part # example: 5V850/3)	Ultra-V Band (Part # example: 3R5V850)
Classical Banded RB, RC, RD	Kraftband	Pix-X'Set MB Banded	Prime Mover Banded (Part # example: B85/3)	Sure Grip Banded (Part # example: 3RBP85)
Light-Duty FHP 2L, 3L, 4L, 5L	Optibelt LD	Pix Light Duty	Glasstex (Part # example: 4L400)	Light-Duty FHP (Part # example: 4L400)

† Timken uses an AP, BP, CP, DP, EP designation for classical v-belts, industry standard is A, B, C, D, E.

* RPP® profile is interchangeable with HTS, PGGT2, HPPD, Hawk and HTD sprockets.

‡ Use Martin MPC® or drop into existing Poly Chain® GT®2 sprockets – not interchangeable with RPP sprockets.

** The part number consists of a prefix and a length designation. Prefixes: 2L = 0, 3L = 1, 4L = 2, 5L = 3

Note: Product names are trademarks of their respective companies.

General Information

Recommended Sheave & Idler Diameters & Proper V-Belt Storage

V-Belt Cross Section	Minimum P.D. Sheave or Inside Idler	Minimum O.D. Flat Backside Idler*
A, AP	3.0	4.5
B, BP	5.0	7.5
C, CP	9.0	13.5
D, DP	13.0	19.5
E, EP	21.0	31.5
AX	2.6	4.0
BX	4.0	6.0
CX	7.0	10.5
DX	11.0	16.5
3V	2.6	—
3VX	2.2	—
5V	7.0	—
5VX	4.3	—
8V	12.4	—
8VX	11.2	—

Minimum Recommended Sheave and Idler Diameters

Belt Cross Section	Belt Length (inches)	Number of Coilings*	Number of Loops*
A, AA, 3V, and B	Under 60.0	None	1
	60.0 to 120.0	1	3
	120.0 to 180.0	2	5
	180.0 and up	3	7
BB, C, and 5V	Under 75.0	None	1
	75.0 to 144.0	1	3
	144.0 to 240.0	2	5
	240.0 and up	3	7
D	Under 120.0	None	1
	120.0 to 240.0	1	3
	240.0 to 330.00	2	5
	330.0 to 420.0	3	7
	420.0 and up	4	9
E and 8V	Under 180.0	None	1
	180.0 to 270.0	1	3
	270.0 to 390.00	2	5
	390.0 to 480.0	3	7
	480.0 and up	4	9

Proper V-Belt Storage Guide

Maximum Number of Coilings for V-Belts Stored on Hooks

Improper or prolonged storage can reduce service life considerably. V-belts should be stored in a cool, dry place with no direct sunlight. If stored on pegs, the longer belts should be coiled in loops of suitable size to prevent distortion from the weight of the belt.

The table on the left, provided by the Association for Rubber Products Manufacturers (ARPM), should be followed for optimum conditions.

*One coiling results in three loops; two coilings result in five loops, etc.

Ensuring long belt life and optimum performance requires more than a quality belt. Carlisle® belts by Timken are backed by a team of experienced sales people, expert engineers, and an array of useful tools that can assist you in properly selecting, installing and maintaining your equipment to realize superior efficiencies and maximum belt life – saving you time and money.

Always eager to assist you in analyzing or designing your next drive, Timken can provide training and guidance in the use of these tools.



Drive Engineer

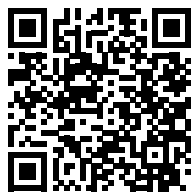

Drive design software can be downloaded at: www.carlisbelts.com/drive-engineer, or scan the QR code provided.

This Windows®-based program is user friendly and facilitates both new drive selection as well as existing drive analysis. The package includes information about part numbers, pricing, horsepower capacity, warnings for drive limits, service factors, hub loads, bushings, diameters, center distance and tensioning – in short, everything needed to design a maximum-efficiency drive system. Drive Engineer is a new generation of analysis software that helps end users increase their drive efficiency, drive life and overall knowledge of belt drives.

Windows® is a registered trademark of Microsoft Corporation.

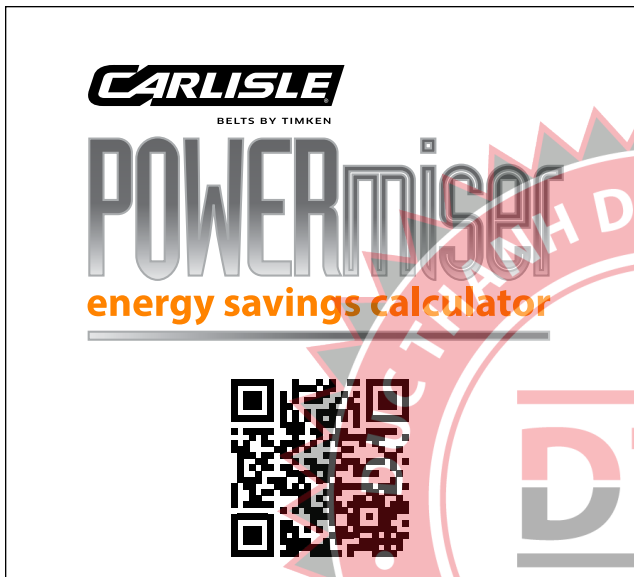

CARLISLE
BELTS BY TIMKEN

POWERMISER

energy savings calculator



PowerMiser

Use the PowerMiser program to calculate the savings you'll realize with Carlisle® belts by Timken.

Simply enter the basic parameters of your drive system such as hours used per year, motor rating (HP), and motor efficiency. Plug in your local utility rate, and select an energy efficient Carlisle belt. PowerMiser does the rest, providing estimated annual energy costs, savings and payback.

PowerMiser is included with Drive Engineer software or can be downloaded as a separate tool at: www.carlislebelts.com/powermiser or scan the QR code provided.



CARLISLE
Industrial V-Belt Drives
Service Manual



Industrial V-Belt Drives Service Manual

Proper belt tensioning and alignment are important for energy efficiency and drive life. Consult Timken's "Industrial V-Belt Drives Service Manual" for helpful tips on proper installation and maintenance of belt drives.

Available at: www.carlislebelts.com/service manual, or scan the QR code provided.



Tension-Finder® V-Belt Tensioning Device

Part Number 108039-A

Eliminate your tensioning headaches with the "Tension-Finder®" – a simple, easy and accurate alternative for tensioning individual v-belts or bands.

- No measurements
- No math
- No computers
- No o-rings

NOTE: Not for use on belts with aramid, glass or carbon fiber cords.

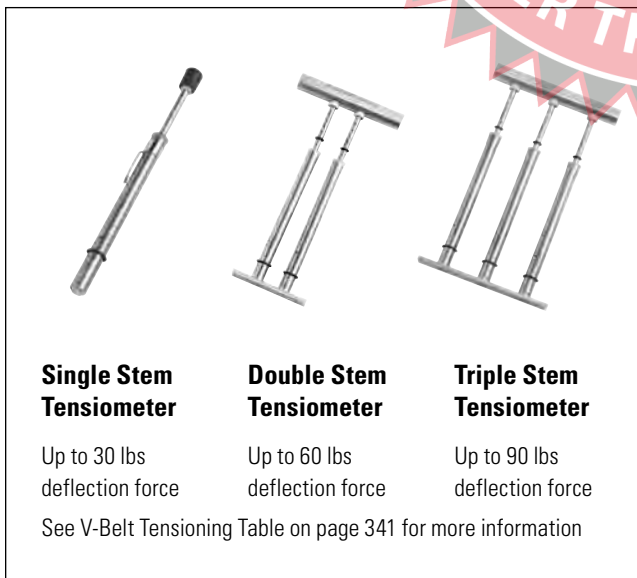

Spring-Loaded Tensiometer

Single Stem
Double Stem
Triple Stem

Part Number 102761
Part Number 105575
Part Number 105576

Proper belt tensioning is one of the most important factors for satisfactory operation and long service life. Too little tension will result in slippage, causing rapid belt and sheave wear. Too much tension can result in excessive stress on the belts, bearings, and shafts.

The force required to deflect a span length by a given amount is related to the tension in the belt. The tensiometer measures that deflection. It can be used on v-belts, banded belts or synchronous belts.



Frequency-Finder

Part Number 109061

The Frequency-Finder is an electronic instrument that precisely measures the frequency used to calculate the static tension in synchronous, v-belts, and v-ribbed belts. It displays the frequency on an LCD screen.

The Frequency-Finder works on the principle of forced vibration. The frequency of vibration is related to the tension of the belt, i.e. the higher the frequency reading, the higher the belt tension.

- Measures the natural frequency of vibration in the belt span
- Simple, fast, repeatable and reliable
- Can be used on any type of belt
- Most precise method

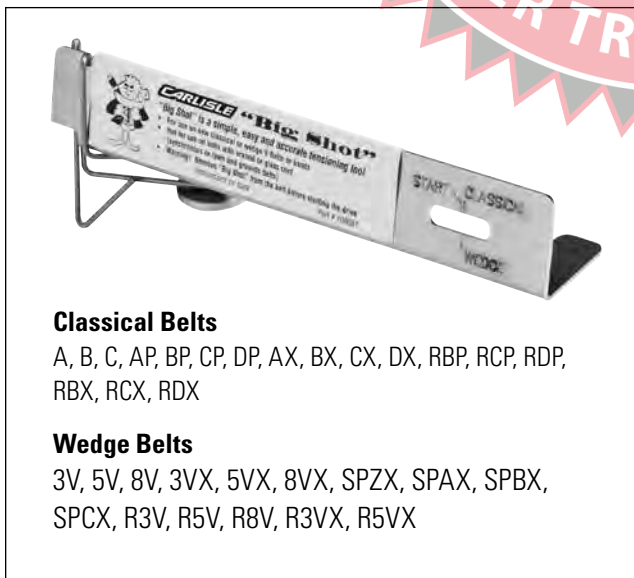

Classical Belts

A, B, C, AP, BP, CP, DP, AX, BX, CX, DX, RBP, RCP, RDP, RBX, RCX, RDX

Wedge Belts

3V, 5V, 8V, 3VX, 5VX, 8VX, SPZX, SPAX, SPBX, SPCX, R3V, R5V, R8V, R3VX, R5VX

Big Shot Tensioning Device

Part Number 109081

A big shot is important and influential. A big shot has a reputation for getting the job done. The Timken "Big Shot" is a quick, easy and accurate device for tensioning new v-belts or bands. It's half the size of the Tension-Finder for use on drives with span lengths of 6"-12", including some HVAC applications.

Proper tensioning is necessary for long, satisfactory operation of any belt drive. Big Shot can be used to tension new classical and wedge v-belts or bands.

NOTE: Not for use on belts with aramid, glass or carbon fiber cords.



Laser-Align

Part Number 109083

Laser-Align is a tool for fast and accurate alignment of belt drive pulleys. Laser-Align is magnetically mounted against the side of one of the pulleys and two magnetic targets are placed against the top, bottom or side of the opposite pulley. The laser projects from the end of the tool onto the targets allowing the user to quickly correct all types of misalignment between the pulleys. Only one person is needed to perfectly align your drives.

Along with proper tensioning, alignment is critical to satisfactory belt life and performance.

A properly aligned drive saves money.

- Reduces wear
- Reduces vibration
- Increases belt life
- Increases energy savings

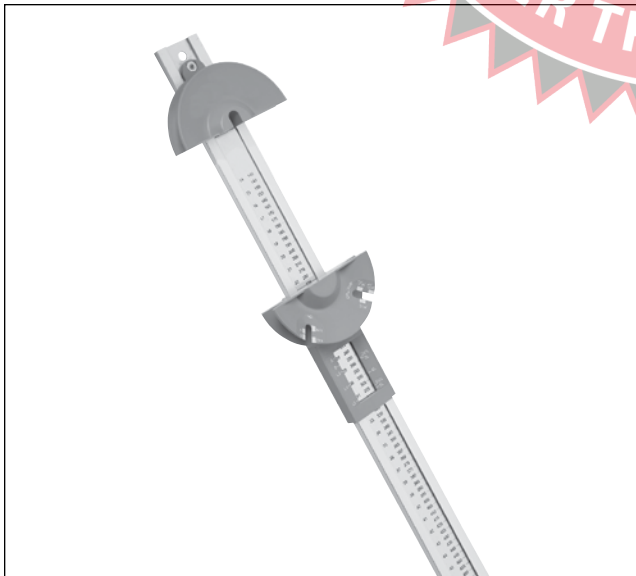

Belt-Finder®

Part Number 93859

This belt measuring device helps you easily find the correct replacement belt. A quick check shows the top width and length of classical (A and B section belts), wedge (3V and 5V section belts) and all FHP belts. The Belt-Finder measures belts up to 100 inches.

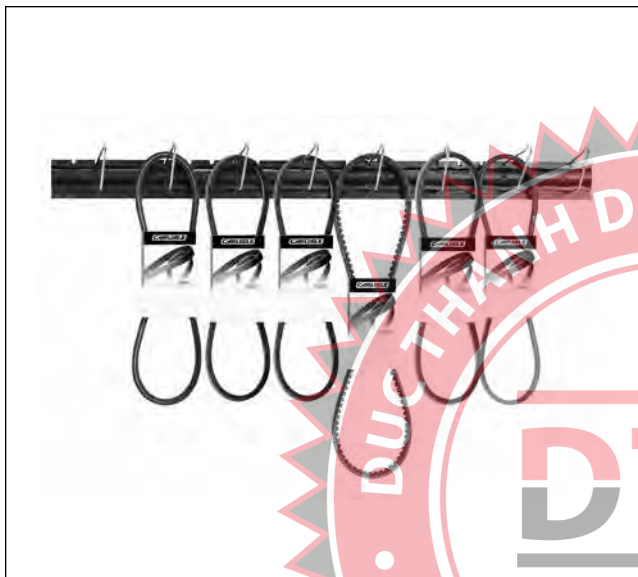

Wallboard Display

Part Number 93899

A popular inventory and display system for v-belts. One box includes 10 boards and 80 hooks. Each board is 36 inches long. The standard 6-inch hooks extend 5-3/8 inches.

Extra hooks come in boxes of 250.

6" hooks, box of 250

8" hooks, box of 250

12" hooks, box of 250

Part Number 93899-H6

Part Number 93899-H8

Part Number 93899-H12

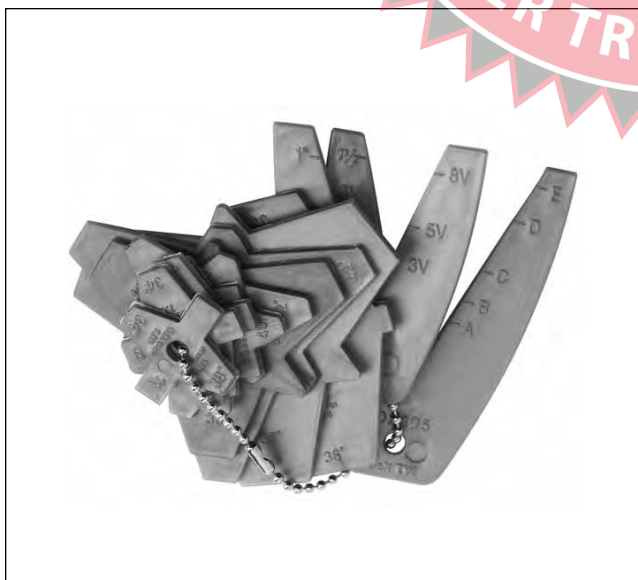

Sheave Gauges

Part Number 102495

Sheave condition and alignment are vital to v-belt life and performance. New v-belts should never be installed without a thorough inspection of the sheaves. Particular attention should be given to wobbling sheaves, a shiny groove bottom and worn groove sidewalls.

Use the sheave gauge to accurately check grooves for wear. A flashlight held behind the template, when placed in the groove, will help you observe the amount of wear. Wear should not exceed 1/32" for individual v-belt drives and 1/64" for banded belt drives.

Notes

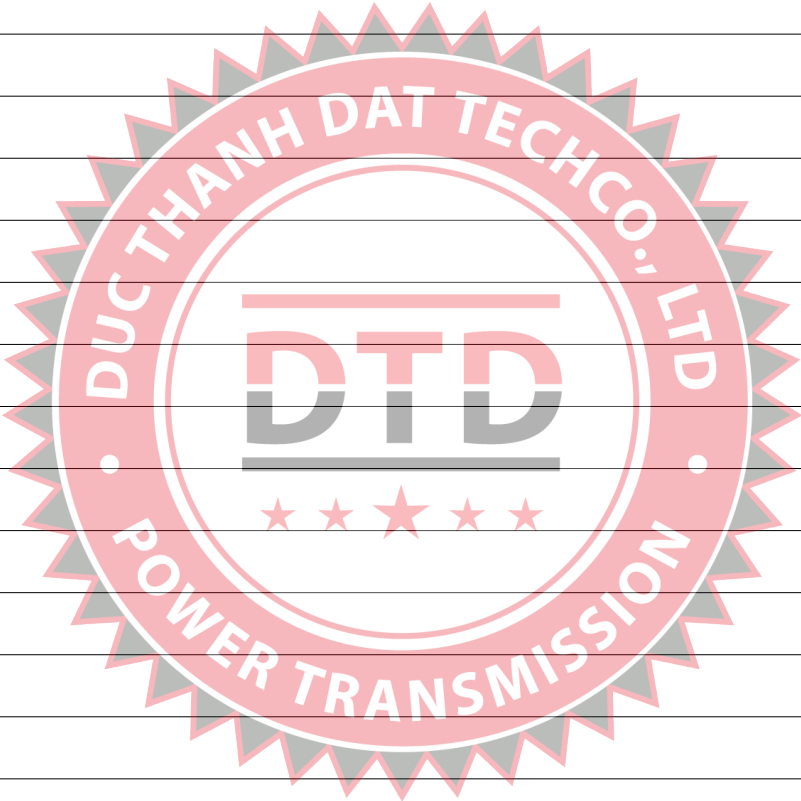

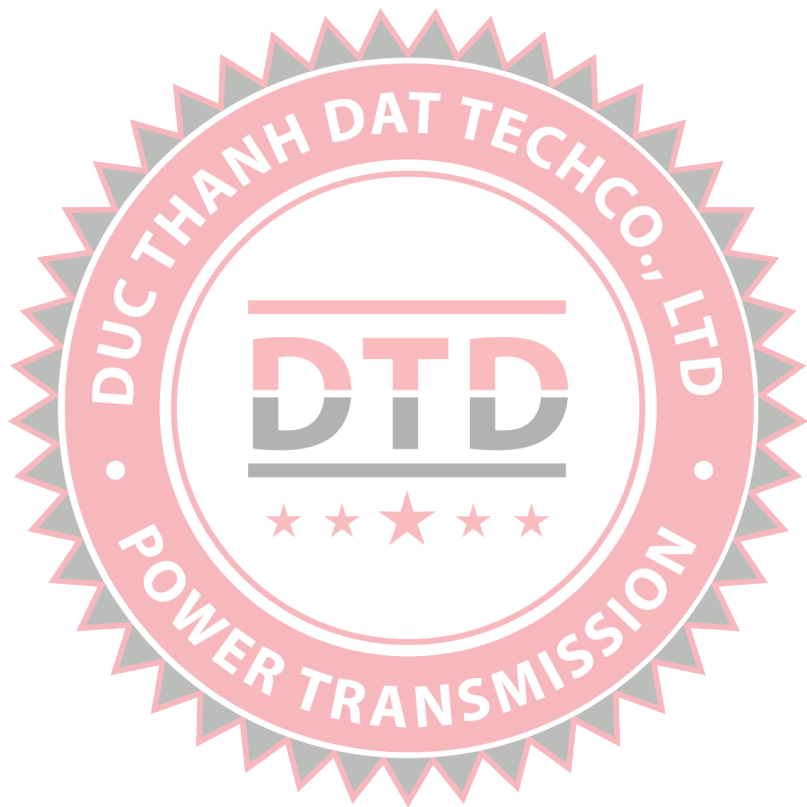

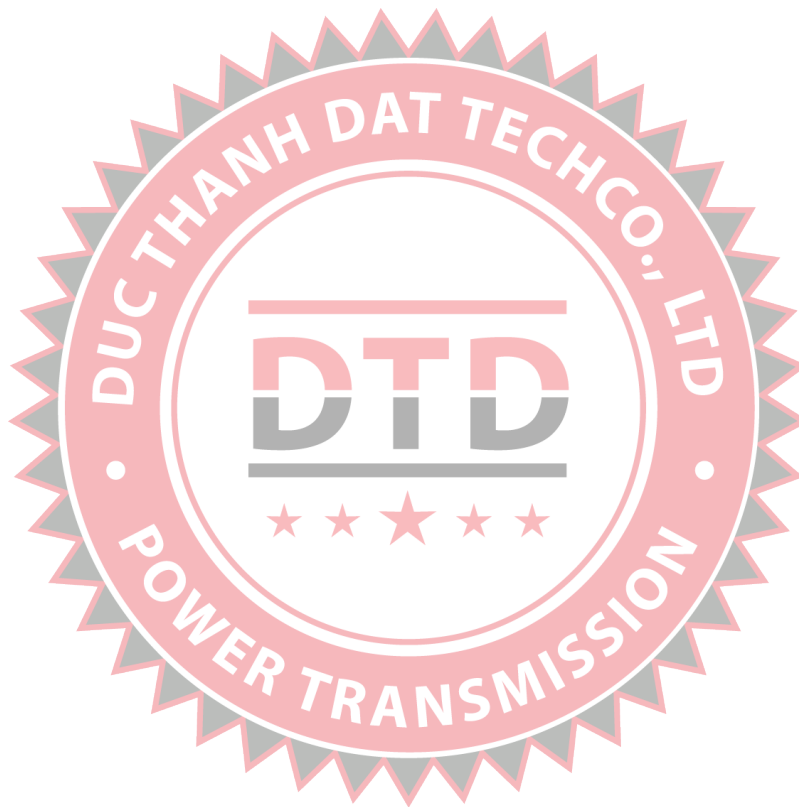

TIMKEN

The Timken team applies their know-how to improve the reliability and performance of machinery in diverse markets worldwide. The company designs, makes and markets high-performance mechanical components, including bearings, belts, gears, chain and related mechanical power transmission products and services.

www.carlislebelts.com

Stronger. By Design.