



Ceptor®-VI

Super torque synchronous belt

Ceptor®-VI



Product brochure
as PDF-File:



PERFORMANCE

Ceptor®-VI advantages:

(1) High power transmission capacity:

High torque transmission of Ceptor VI for lower speed range.

(2) High strength tension members:

Ceptor VI uses high strength tension members, therefore it has less elongation and longer life time.

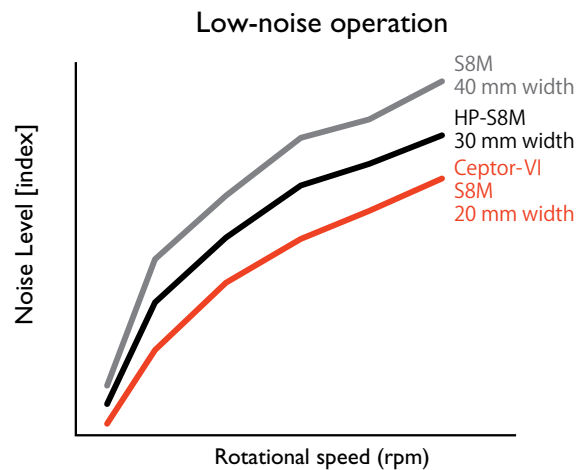
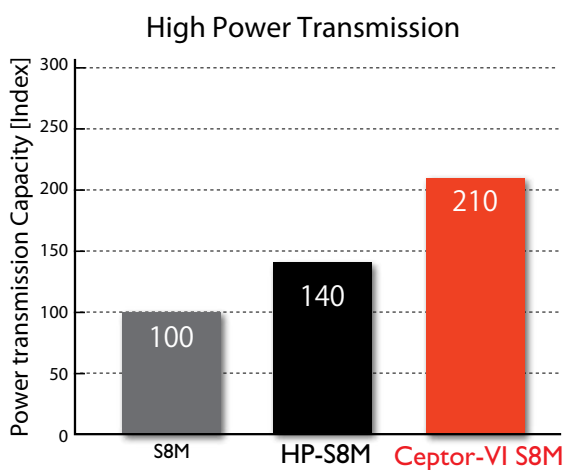

(3) Compact design:

Ceptor VI offers narrow belt design for operations in limited design space.

(4) Noise Reduction:

Low noise performance due to the narrow belt width.

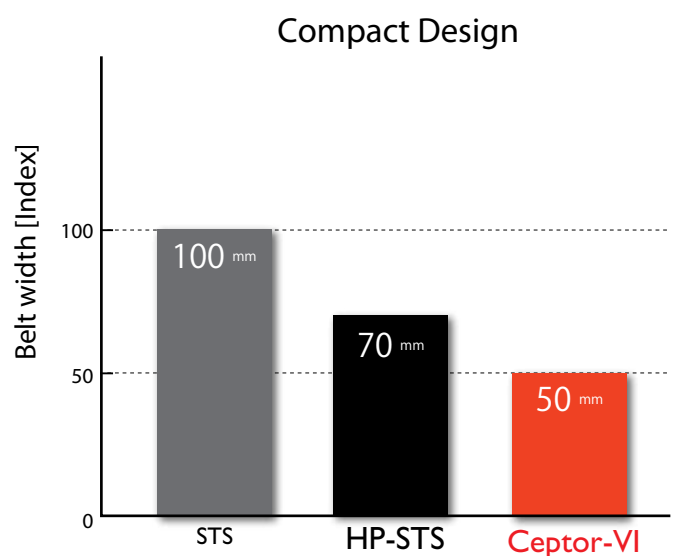
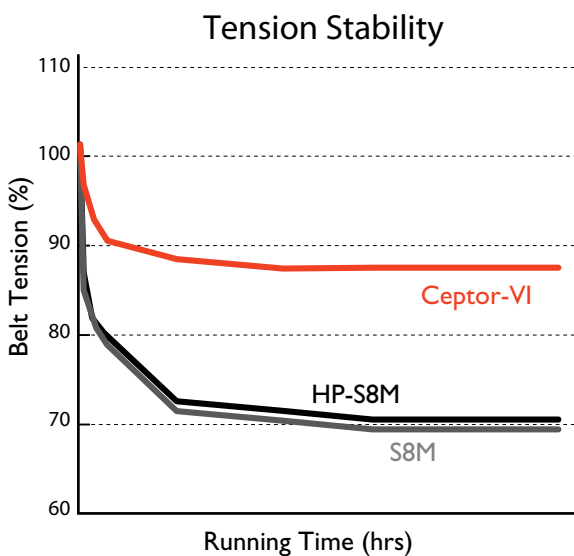

SIZE LIST

BANDO Ceptor-VI is the right choice, if your application needs even more performance than STS and HP-STC belts.

| Belt shape | P | h | H |
|----------------|------|------|------|
| Ceptor-VI S3M | 3.0 | 1.14 | 2.10 |
| Ceptor-VI S5M | 5.0 | 1.91 | 3.61 |
| Ceptor-VI S8M | 8.0 | 3.05 | 5.00 |
| Ceptor-VI S14M | 14.0 | 5.30 | 8.70 |

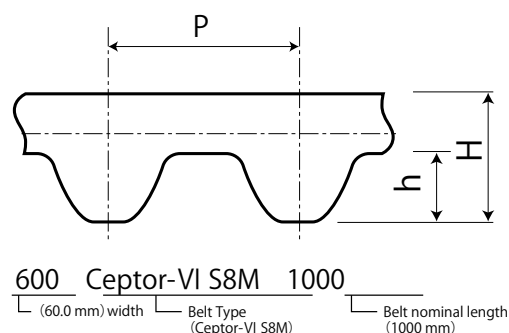

Standard width:

| Belt length (mm) | 60 | 100 | 0150 | 0200 | 0250 | 0400 | 0600 | 0800 | 1000 | 1200 |
|------------------|----|-----|------|------|------|------|------|------|------|------|
| Width (mm) | 6 | 10 | 15 | 20 | 25 | 40 | 60 | 80 | 100 | 120 |
| S3M | ● | ● | ● | | | | | | | |
| S5M | | ● | ● | ● | ● | | | | | |
| S8M | | | ● | | ● | ● | ● | | | |
| S14M | | | | | | ● | ● | ● | ● | ● |

* Please contact us for other belt width, or about the belt design.

Ceptor VI initial tension:

| Belt Width (mm) | S5M | | S5M | | S8M | | S14M | |
|-----------------|-----|-----|-----|-----|------|------|------|------|
| | MIN | MAX | MIN | MAX | MIN | MAX | MIN | MAX |
| 6 | 26 | 43 | | | | | | |
| 10 | 47 | 78 | 89 | 153 | | | | |
| 15 | 74 | 122 | 143 | 248 | 350 | 390 | | |
| 20 | | | 198 | 342 | | | | |
| 25 | | | 254 | 437 | 600 | 680 | | |
| 40 | | | | | 1010 | 1160 | 1550 | 1630 |
| 60 | | | | | 1610 | 1830 | 2410 | 2540 |
| 80 | | | | | | | 3370 | 3550 |
| 100 | | | | | | | 4330 | 4550 |
| 120 | | | | | | | 5340 | 5620 |

* UNIT : N

USAGE EXAMPLES

Press- and Stamping machinery

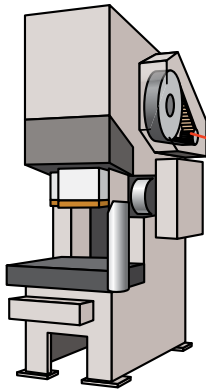

Ceptor VI S8M
Ceptor VI S14M

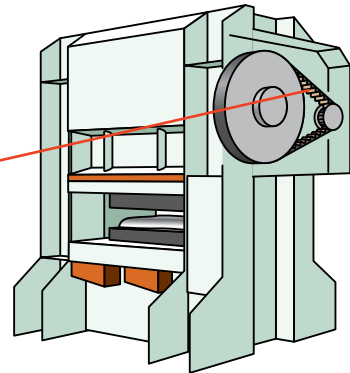

Industrial Robots

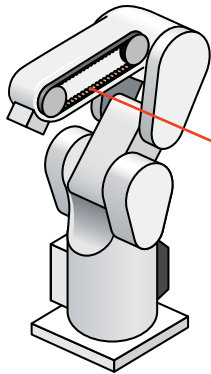

Ceptor VI S5M
Ceptor VI S8M

Toys

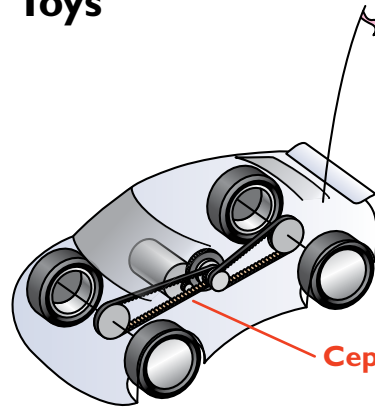

Ceptor VI S3M

Medical devices

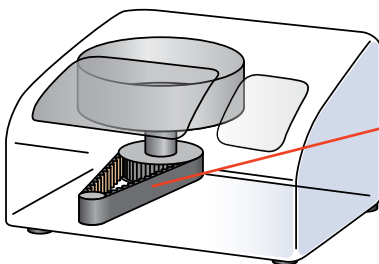

Ceptor VI S3M
Ceptor VI S5M

Bookbinding machine

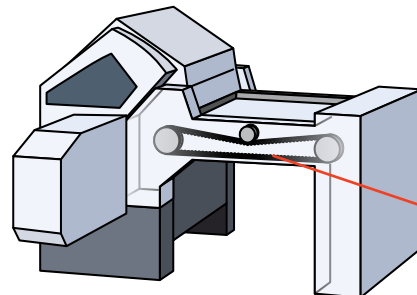

Ceptor VI S5M
Ceptor VI S8M

Linear Robots

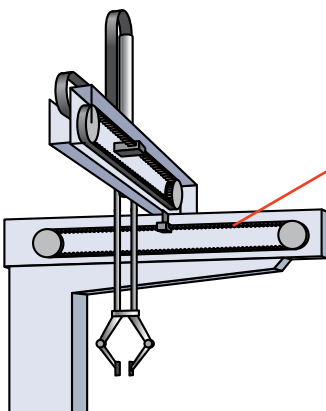

Ceptor VI S5M
Ceptor VI S8M

Kitchen Food Mixer

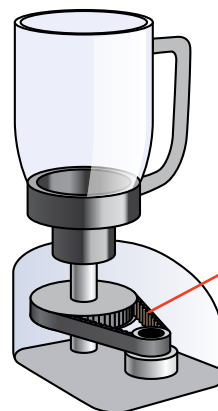

Ceptor VI S3M
Ceptor VI S5M

PRODUCT LINE-UP

Ceptor-VI S3M

| Description | Pitch Length (mm) | No. of Teeth |
|-------------------|-------------------|--------------|
| Ceptor-VI S3M 93 | 93 | 31 |
| Ceptor-VI S3M 120 | 120 | 40 |
| Ceptor-VI S3M 123 | 123 | 41 |
| Ceptor-VI S3M 129 | 129 | 43 |
| Ceptor-VI S3M 132 | 132 | 44 |
| Ceptor-VI S3M 141 | 141 | 47 |
| Ceptor-VI S3M 144 | 144 | 48 |
| Ceptor-VI S3M 147 | 147 | 49 |
| Ceptor-VI S3M 150 | 150 | 50 |
| Ceptor-VI S3M 156 | 156 | 52 |
| Ceptor-VI S3M 159 | 159 | 53 |
| Ceptor-VI S3M 162 | 162 | 54 |
| Ceptor-VI S3M 168 | 168 | 56 |
| Ceptor-VI S3M 171 | 171 | 57 |
| Ceptor-VI S3M 174 | 174 | 58 |
| Ceptor-VI S3M 177 | 177 | 59 |
| Ceptor-VI S3M 180 | 180 | 60 |
| Ceptor-VI S3M 183 | 183 | 61 |
| Ceptor-VI S3M 186 | 186 | 62 |
| Ceptor-VI S3M 189 | 189 | 63 |
| Ceptor-VI S3M 192 | 192 | 64 |
| Ceptor-VI S3M 195 | 195 | 65 |
| Ceptor-VI S3M 198 | 198 | 66 |
| Ceptor-VI S3M 201 | 201 | 67 |
| Ceptor-VI S3M 204 | 204 | 68 |
| Ceptor-VI S3M 207 | 207 | 69 |
| Ceptor-VI S3M 210 | 210 | 70 |
| Ceptor-VI S3M 213 | 213 | 71 |
| Ceptor-VI S3M 219 | 219 | 73 |
| Ceptor-VI S3M 222 | 222 | 74 |
| Ceptor-VI S3M 225 | 225 | 75 |
| Ceptor-VI S3M 228 | 228 | 76 |
| Ceptor-VI S3M 234 | 234 | 78 |
| Ceptor-VI S3M 237 | 237 | 79 |
| Ceptor-VI S3M 240 | 240 | 80 |
| Ceptor-VI S3M 243 | 243 | 81 |
| Ceptor-VI S3M 246 | 246 | 82 |
| Ceptor-VI S3M 249 | 249 | 83 |
| Ceptor-VI S3M 252 | 252 | 84 |
| Ceptor-VI S3M 255 | 255 | 85 |
| Ceptor-VI S3M 258 | 258 | 86 |
| Ceptor-VI S3M 264 | 264 | 88 |
| Ceptor-VI S3M 267 | 267 | 89 |
| Ceptor-VI S3M 270 | 270 | 90 |
| Ceptor-VI S3M 273 | 273 | 91 |
| Ceptor-VI S3M 276 | 276 | 92 |
| Ceptor-VI S3M 279 | 279 | 93 |
| Ceptor-VI S3M 282 | 282 | 94 |
| Ceptor-VI S3M 285 | 285 | 95 |
| Ceptor-VI S3M 288 | 288 | 96 |
| Ceptor-VI S3M 291 | 291 | 97 |
| Ceptor-VI S3M 294 | 294 | 98 |
| Ceptor-VI S3M 297 | 297 | 99 |
| Ceptor-VI S3M 300 | 300 | 100 |
| Ceptor-VI S3M 303 | 303 | 101 |
| Ceptor-VI S3M 306 | 306 | 102 |
| Ceptor-VI S3M 309 | 309 | 103 |
| Ceptor-VI S3M 312 | 312 | 104 |
| Ceptor-VI S3M 315 | 315 | 105 |
| Ceptor-VI S3M 318 | 318 | 106 |
| Ceptor-VI S3M 324 | 324 | 108 |
| Ceptor-VI S3M 327 | 327 | 109 |

| Description | Pitch Length (mm) | No. of Teeth |
|-------------------|-------------------|--------------|
| Ceptor-VI S3M 330 | 330 | 110 |
| Ceptor-VI S3M 333 | 333 | 111 |
| Ceptor-VI S3M 336 | 336 | 112 |
| Ceptor-VI S3M 339 | 339 | 113 |
| Ceptor-VI S3M 342 | 342 | 114 |
| Ceptor-VI S3M 351 | 351 | 117 |
| Ceptor-VI S3M 354 | 354 | 118 |
| Ceptor-VI S3M 360 | 360 | 120 |
| Ceptor-VI S3M 363 | 363 | 121 |
| Ceptor-VI S3M 366 | 366 | 122 |
| Ceptor-VI S3M 369 | 369 | 123 |
| Ceptor-VI S3M 372 | 372 | 124 |
| Ceptor-VI S3M 375 | 375 | 125 |
| Ceptor-VI S3M 378 | 378 | 126 |
| Ceptor-VI S3M 384 | 384 | 128 |
| Ceptor-VI S3M 387 | 387 | 129 |
| Ceptor-VI S3M 390 | 390 | 130 |
| Ceptor-VI S3M 396 | 396 | 132 |
| Ceptor-VI S3M 399 | 399 | 133 |
| Ceptor-VI S3M 402 | 402 | 134 |
| Ceptor-VI S3M 405 | 405 | 135 |
| Ceptor-VI S3M 408 | 408 | 136 |
| Ceptor-VI S3M 417 | 417 | 139 |
| Ceptor-VI S3M 420 | 420 | 140 |
| Ceptor-VI S3M 423 | 423 | 141 |
| Ceptor-VI S3M 426 | 426 | 142 |
| Ceptor-VI S3M 432 | 432 | 144 |
| Ceptor-VI S3M 438 | 438 | 146 |
| Ceptor-VI S3M 444 | 444 | 148 |
| Ceptor-VI S3M 447 | 447 | 149 |
| Ceptor-VI S3M 453 | 453 | 151 |
| Ceptor-VI S3M 456 | 456 | 152 |
| Ceptor-VI S3M 459 | 459 | 153 |
| Ceptor-VI S3M 468 | 468 | 156 |
| Ceptor-VI S3M 471 | 471 | 157 |
| Ceptor-VI S3M 474 | 474 | 158 |
| Ceptor-VI S3M 480 | 480 | 160 |
| Ceptor-VI S3M 486 | 486 | 162 |
| Ceptor-VI S3M 489 | 489 | 163 |
| Ceptor-VI S3M 492 | 492 | 164 |
| Ceptor-VI S3M 498 | 498 | 166 |
| Ceptor-VI S3M 501 | 501 | 167 |
| Ceptor-VI S3M 507 | 507 | 169 |
| Ceptor-VI S3M 513 | 513 | 171 |
| Ceptor-VI S3M 516 | 516 | 172 |
| Ceptor-VI S3M 519 | 519 | 173 |
| Ceptor-VI S3M 522 | 522 | 174 |
| Ceptor-VI S3M 525 | 525 | 175 |
| Ceptor-VI S3M 534 | 534 | 178 |
| Ceptor-VI S3M 537 | 537 | 179 |
| Ceptor-VI S3M 540 | 540 | 180 |
| Ceptor-VI S3M 549 | 549 | 183 |
| Ceptor-VI S3M 552 | 552 | 184 |
| Ceptor-VI S3M 555 | 555 | 185 |
| Ceptor-VI S3M 564 | 564 | 188 |
| Ceptor-VI S3M 573 | 573 | 191 |
| Ceptor-VI S3M 579 | 579 | 193 |
| Ceptor-VI S3M 588 | 588 | 196 |

| Description | Pitch Length (mm) | No. of Teeth |
|---------------------|-------------------|--------------|
| Ceptor-VI S3M 597 | 597 | 199 |
| Ceptor-VI S3M 600 | 600 | 200 |
| Ceptor-VI S3M 609 | 609 | 203 |
| Ceptor-VI S3M 621 | 621 | 207 |
| Ceptor-VI S3M 633 | 633 | 211 |
| Ceptor-VI S3M 636 | 636 | 212 |
| Ceptor-VI S3M 648 | 648 | 216 |
| Ceptor-VI S3M 657 | 657 | 219 |
| Ceptor-VI S3M 660 | 660 | 220 |
| Ceptor-VI S3M 666 | 666 | 222 |
| Ceptor-VI S3M 681 | 681 | 227 |
| Ceptor-VI S3M 690 | 690 | 230 |
| Ceptor-VI S3M 699 | 699 | 233 |
| Ceptor-VI S3M 720 | 720 | 240 |
| Ceptor-VI S3M 726 | 726 | 242 |
| Ceptor-VI S3M 735 | 735 | 245 |
| Ceptor-VI S3M 741 | 741 | 247 |
| Ceptor-VI S3M 750 | 750 | 250 |
| Ceptor-VI S3M 768 | 768 | 256 |
| Ceptor-VI S3M 771 | 771 | 257 |
| Ceptor-VI S3M 789 | 789 | 263 |
| Ceptor-VI S3M 804 | 804 | 268 |
| Ceptor-VI S3M 810 | 810 | 270 |
| Ceptor-VI S3M 825 | 825 | 275 |
| Ceptor-VI S3M 852 | 852 | 284 |
| Ceptor-VI S3M 858 | 858 | 286 |
| Ceptor-VI S3M 882 | 882 | 294 |
| Ceptor-VI S3M 885 | 885 | 295 |
| Ceptor-VI S3M 888 | 888 | 296 |
| Ceptor-VI S3M 900 | 900 | 300 |
| Ceptor-VI S3M 909 | 909 | 303 |
| Ceptor-VI S3M 918 | 918 | 306 |
| Ceptor-VI S3M 927 | 927 | 309 |
| Ceptor-VI S3M 936 | 936 | 312 |
| Ceptor-VI S3M 954 | 954 | 318 |
| Ceptor-VI S3M 990 | 990 | 330 |
| Ceptor-VI S3M 999 | 999 | 333 |
| Ceptor-VI S3M 1.014 | 1.014 | 338 |
| Ceptor-VI S3M 1.050 | 1.050 | 350 |
| Ceptor-VI S3M 1.080 | 1.080 | 360 |
| Ceptor-VI S3M 1.119 | 1.119 | 373 |
| Ceptor-VI S3M 1.134 | 1.134 | 378 |
| Ceptor-VI S3M 1.146 | 1.146 | 382 |
| Ceptor-VI S3M 1.170 | 1.170 | 390 |
| Ceptor-VI S3M 1.176 | 1.176 | 392 |
| Ceptor-VI S3M 1.188 | 1.188 | 396 |
| Ceptor-VI S3M 1.203 | 1.203 | 401 |
| Ceptor-VI S3M 1.221 | 1.221 | 407 |
| Ceptor-VI S3M 1.236 | 1.236 | 412 |
| Ceptor-VI S3M 1.245 | 1.245 | 415 |
| Ceptor-VI S3M 1.290 | 1.290 | 430 |
| Ceptor-VI S3M 1.299 | 1.299 | 433 |
| Ceptor-VI S3M 1.332 | 1.332 | 444 |
| Ceptor-VI S3M 1.401 | 1.401 | 467 |
| Ceptor-VI S3M 1.419 | 1.419 | 473 |
| Ceptor-VI S3M 1.530 | 1.530 | 510 |
| Ceptor-VI S3M 1.680 | 1.680 | 560 |
| Ceptor-VI S3M 1.788 | 1.788 | 596 |

PRODUCT LINE-UP

Ceptor-VI S5M

| Description | Pitch Length (mm) | No. of Teeth |
|-------------------|-------------------|--------------|
| Ceptor-VI S5M 225 | 225 | 45 |
| Ceptor-VI S5M 230 | 230 | 46 |
| Ceptor-VI S5M 255 | 255 | 51 |
| Ceptor-VI S5M 260 | 260 | 52 |
| Ceptor-VI S5M 275 | 275 | 55 |
| Ceptor-VI S5M 285 | 285 | 57 |
| Ceptor-VI S5M 295 | 295 | 59 |
| Ceptor-VI S5M 300 | 300 | 60 |
| Ceptor-VI S5M 305 | 305 | 61 |
| Ceptor-VI S5M 320 | 320 | 64 |
| Ceptor-VI S5M 325 | 325 | 65 |
| Ceptor-VI S5M 340 | 340 | 68 |
| Ceptor-VI S5M 350 | 350 | 70 |
| Ceptor-VI S5M 360 | 360 | 72 |
| Ceptor-VI S5M 370 | 370 | 74 |
| Ceptor-VI S5M 375 | 375 | 75 |
| Ceptor-VI S5M 380 | 380 | 76 |
| Ceptor-VI S5M 390 | 390 | 78 |
| Ceptor-VI S5M 400 | 400 | 80 |
| Ceptor-VI S5M 410 | 410 | 82 |
| Ceptor-VI S5M 415 | 415 | 83 |
| Ceptor-VI S5M 420 | 420 | 84 |
| Ceptor-VI S5M 425 | 425 | 85 |
| Ceptor-VI S5M 435 | 435 | 87 |
| Ceptor-VI S5M 440 | 440 | 88 |
| Ceptor-VI S5M 445 | 445 | 89 |
| Ceptor-VI S5M 450 | 450 | 90 |
| Ceptor-VI S5M 475 | 475 | 95 |
| Ceptor-VI S5M 490 | 490 | 98 |
| Ceptor-VI S5M 500 | 500 | 100 |
| Ceptor-VI S5M 520 | 520 | 104 |
| Ceptor-VI S5M 525 | 525 | 105 |
| Ceptor-VI S5M 530 | 530 | 106 |
| Ceptor-VI S5M 545 | 545 | 109 |
| Ceptor-VI S5M 550 | 550 | 110 |
| Ceptor-VI S5M 560 | 560 | 112 |

| Description | Pitch Length (mm) | No. of Teeth |
|-------------------|-------------------|--------------|
| Ceptor-VI S5M 565 | 565 | 113 |
| Ceptor-VI S5M 570 | 570 | 114 |
| Ceptor-VI S5M 575 | 575 | 115 |
| Ceptor-VI S5M 590 | 590 | 118 |
| Ceptor-VI S5M 595 | 595 | 119 |
| Ceptor-VI S5M 600 | 600 | 120 |
| Ceptor-VI S5M 625 | 625 | 125 |
| Ceptor-VI S5M 635 | 635 | 127 |
| Ceptor-VI S5M 640 | 640 | 128 |
| Ceptor-VI S5M 645 | 645 | 129 |
| Ceptor-VI S5M 650 | 650 | 130 |
| Ceptor-VI S5M 665 | 665 | 133 |
| Ceptor-VI S5M 670 | 670 | 134 |
| Ceptor-VI S5M 675 | 675 | 135 |
| Ceptor-VI S5M 690 | 690 | 138 |
| Ceptor-VI S5M 695 | 695 | 139 |
| Ceptor-VI S5M 700 | 700 | 140 |
| Ceptor-VI S5M 710 | 710 | 142 |
| Ceptor-VI S5M 720 | 720 | 144 |
| Ceptor-VI S5M 725 | 725 | 145 |
| Ceptor-VI S5M 740 | 740 | 148 |
| Ceptor-VI S5M 750 | 750 | 150 |
| Ceptor-VI S5M 765 | 765 | 153 |
| Ceptor-VI S5M 770 | 770 | 154 |
| Ceptor-VI S5M 775 | 775 | 155 |
| Ceptor-VI S5M 780 | 780 | 156 |
| Ceptor-VI S5M 800 | 800 | 160 |
| Ceptor-VI S5M 810 | 810 | 162 |
| Ceptor-VI S5M 830 | 830 | 166 |
| Ceptor-VI S5M 845 | 845 | 169 |
| Ceptor-VI S5M 850 | 850 | 170 |
| Ceptor-VI S5M 860 | 860 | 172 |
| Ceptor-VI S5M 870 | 870 | 174 |
| Ceptor-VI S5M 890 | 890 | 178 |
| Ceptor-VI S5M 900 | 900 | 180 |
| Ceptor-VI S5M 920 | 920 | 184 |

| Description | Pitch Length (mm) | No. of Teeth |
|--------------------|-------------------|--------------|
| Ceptor-VI S5M 930 | 930 | 186 |
| Ceptor-VI S5M 940 | 940 | 188 |
| Ceptor-VI S5M 950 | 950 | 190 |
| Ceptor-VI S5M 965 | 965 | 193 |
| Ceptor-VI S5M 975 | 975 | 195 |
| Ceptor-VI S5M 1000 | 1.000 | 200 |
| Ceptor-VI S5M 1025 | 1.025 | 205 |
| Ceptor-VI S5M 1050 | 1.050 | 210 |
| Ceptor-VI S5M 1055 | 1.055 | 211 |
| Ceptor-VI S5M 1085 | 1.085 | 217 |
| Ceptor-VI S5M 1090 | 1.090 | 218 |
| Ceptor-VI S5M 1100 | 1.100 | 220 |
| Ceptor-VI S5M 1105 | 1.105 | 221 |
| Ceptor-VI S5M 1115 | 1.115 | 223 |
| Ceptor-VI S5M 1120 | 1.120 | 224 |
| Ceptor-VI S5M 1125 | 1.125 | 225 |
| Ceptor-VI S5M 1135 | 1.135 | 227 |
| Ceptor-VI S5M 1145 | 1.145 | 229 |
| Ceptor-VI S5M 1160 | 1.160 | 232 |
| Ceptor-VI S5M 1165 | 1.165 | 233 |
| Ceptor-VI S5M 1195 | 1.195 | 239 |
| Ceptor-VI S5M 1225 | 1.225 | 245 |
| Ceptor-VI S5M 1250 | 1.250 | 250 |
| Ceptor-VI S5M 1260 | 1.260 | 252 |
| Ceptor-VI S5M 1270 | 1.270 | 254 |
| Ceptor-VI S5M 1295 | 1.295 | 259 |
| Ceptor-VI S5M 1350 | 1.350 | 270 |
| Ceptor-VI S5M 1420 | 1.420 | 284 |
| Ceptor-VI S5M 1500 | 1.500 | 300 |
| Ceptor-VI S5M 1505 | 1.505 | 301 |
| Ceptor-VI S5M 1530 | 1.530 | 306 |
| Ceptor-VI S5M 1595 | 1.595 | 319 |
| Ceptor-VI S5M 1605 | 1.605 | 321 |
| Ceptor-VI S5M 1680 | 1.680 | 336 |
| Ceptor-VI S5M 1715 | 1.715 | 343 |
| Ceptor-VI S5M 1800 | 1.800 | 360 |
| Ceptor-VI S5M 2000 | 2.000 | 400 |



Product Line-Up

Ceptor-VI S8M

| Description | Pitch Length (mm) | No. of Teeth |
|-------------------|-------------------|--------------|
| Ceptor-VI S8M 352 | 352 | 44 |
| Ceptor-VI S8M 384 | 384 | 48 |
| Ceptor-VI S8M 408 | 408 | 51 |
| Ceptor-VI S8M 424 | 424 | 53 |
| Ceptor-VI S8M 440 | 440 | 55 |
| Ceptor-VI S8M 456 | 456 | 57 |
| Ceptor-VI S8M 480 | 480 | 60 |
| Ceptor-VI S8M 496 | 496 | 62 |
| Ceptor-VI S8M 512 | 512 | 64 |
| Ceptor-VI S8M 520 | 520 | 65 |
| Ceptor-VI S8M 528 | 528 | 66 |
| Ceptor-VI S8M 560 | 560 | 70 |
| Ceptor-VI S8M 584 | 584 | 73 |
| Ceptor-VI S8M 600 | 600 | 75 |
| Ceptor-VI S8M 632 | 632 | 79 |
| Ceptor-VI S8M 640 | 640 | 80 |
| Ceptor-VI S8M 656 | 656 | 82 |
| Ceptor-VI S8M 672 | 672 | 84 |
| Ceptor-VI S8M 680 | 680 | 85 |
| Ceptor-VI S8M 712 | 712 | 89 |
| Ceptor-VI S8M 720 | 720 | 90 |
| Ceptor-VI S8M 728 | 728 | 91 |
| Ceptor-VI S8M 760 | 760 | 95 |
| Ceptor-VI S8M 800 | 800 | 100 |
| Ceptor-VI S8M 824 | 824 | 103 |
| Ceptor-VI S8M 840 | 840 | 105 |
| Ceptor-VI S8M 848 | 848 | 106 |
| Ceptor-VI S8M 880 | 880 | 110 |
| Ceptor-VI S8M 888 | 888 | 111 |
| Ceptor-VI S8M 896 | 896 | 112 |
| Ceptor-VI S8M 920 | 920 | 115 |
| Ceptor-VI S8M 944 | 944 | 118 |

| Description | Pitch Length (mm) | No. of Teeth |
|--------------------|-------------------|--------------|
| Ceptor-VI S8M 960 | 960 | 120 |
| Ceptor-VI S8M 976 | 976 | 122 |
| Ceptor-VI S8M 984 | 984 | 123 |
| Ceptor-VI S8M 1000 | 1.000 | 125 |
| Ceptor-VI S8M 1032 | 1.032 | 129 |
| Ceptor-VI S8M 1040 | 1.040 | 130 |
| Ceptor-VI S8M 1056 | 1.056 | 132 |
| Ceptor-VI S8M 1080 | 1.080 | 135 |
| Ceptor-VI S8M 1096 | 1.096 | 137 |
| Ceptor-VI S8M 1120 | 1.120 | 140 |
| Ceptor-VI S8M 1136 | 1.136 | 142 |
| Ceptor-VI S8M 1152 | 1.152 | 144 |
| Ceptor-VI S8M 1160 | 1.160 | 145 |
| Ceptor-VI S8M 1184 | 1.184 | 148 |
| Ceptor-VI S8M 1192 | 1.192 | 149 |
| Ceptor-VI S8M 1200 | 1.200 | 150 |
| Ceptor-VI S8M 1216 | 1.216 | 152 |
| Ceptor-VI S8M 1224 | 1.224 | 153 |
| Ceptor-VI S8M 1240 | 1.240 | 155 |
| Ceptor-VI S8M 1248 | 1.248 | 156 |
| Ceptor-VI S8M 1272 | 1.272 | 159 |
| Ceptor-VI S8M 1280 | 1.280 | 160 |
| Ceptor-VI S8M 1296 | 1.296 | 162 |
| Ceptor-VI S8M 1312 | 1.312 | 164 |
| Ceptor-VI S8M 1344 | 1.344 | 168 |
| Ceptor-VI S8M 1352 | 1.352 | 169 |
| Ceptor-VI S8M 1360 | 1.360 | 170 |
| Ceptor-VI S8M 1384 | 1.384 | 173 |
| Ceptor-VI S8M 1392 | 1.392 | 174 |
| Ceptor-VI S8M 1400 | 1.400 | 175 |
| Ceptor-VI S8M 1424 | 1.424 | 178 |
| Ceptor-VI S8M 1440 | 1.440 | 180 |

| Description | Pitch Length (mm) | No. of Teeth |
|--------------------|-------------------|--------------|
| Ceptor-VI S8M 1480 | 1.480 | 185 |
| Ceptor-VI S8M 1520 | 1.520 | 190 |
| Ceptor-VI S8M 1552 | 1.552 | 194 |
| Ceptor-VI S8M 1600 | 1.600 | 200 |
| Ceptor-VI S8M 1648 | 1.648 | 206 |
| Ceptor-VI S8M 1680 | 1.680 | 210 |
| Ceptor-VI S8M 1728 | 1.728 | 216 |
| Ceptor-VI S8M 1760 | 1.760 | 220 |
| Ceptor-VI S8M 1776 | 1.776 | 222 |
| Ceptor-VI S8M 1800 | 1.800 | 225 |
| Ceptor-VI S8M 1808 | 1.808 | 226 |
| Ceptor-VI S8M 1880 | 1.880 | 235 |
| Ceptor-VI S8M 1912 | 1.912 | 239 |
| Ceptor-VI S8M 1952 | 1.952 | 244 |
| Ceptor-VI S8M 2000 | 2.000 | 250 |
| Ceptor-VI S8M 2040 | 2.040 | 255 |
| Ceptor-VI S8M 2120 | 2.120 | 265 |
| Ceptor-VI S8M 2160 | 2.160 | 270 |
| Ceptor-VI S8M 2240 | 2.240 | 280 |
| Ceptor-VI S8M 2304 | 2.304 | 288 |
| Ceptor-VI S8M 2400 | 2.400 | 300 |
| Ceptor-VI S8M 2496 | 2.496 | 312 |
| Ceptor-VI S8M 2560 | 2.560 | 320 |
| Ceptor-VI S8M 2600 | 2.600 | 325 |
| Ceptor-VI S8M 2800 | 2.800 | 350 |
| Ceptor-VI S8M 2880 | 2.880 | 360 |
| Ceptor-VI S8M 2944 | 2.944 | 368 |
| Ceptor-VI S8M 3200 | 3.200 | 400 |
| Ceptor-VI S8M 3600 | 3.600 | 450 |
| Ceptor-VI S8M 3720 | 3.720 | 465 |
| Ceptor-VI S8M 3904 | 3.904 | 488 |
| Ceptor-VI S8M 4400 | 4.400 | 550 |

* Please note that this catalogue is reserved to changes. All data in this publication have been compiled and checked with utmost diligence, nevertheless errors and mistakes cannot be totally excluded. Do not duplicate or copy any part or contents without the permission of Bando Europe GmbH.